

Coffee Table

Assembly Instructions - Please keep for future reference

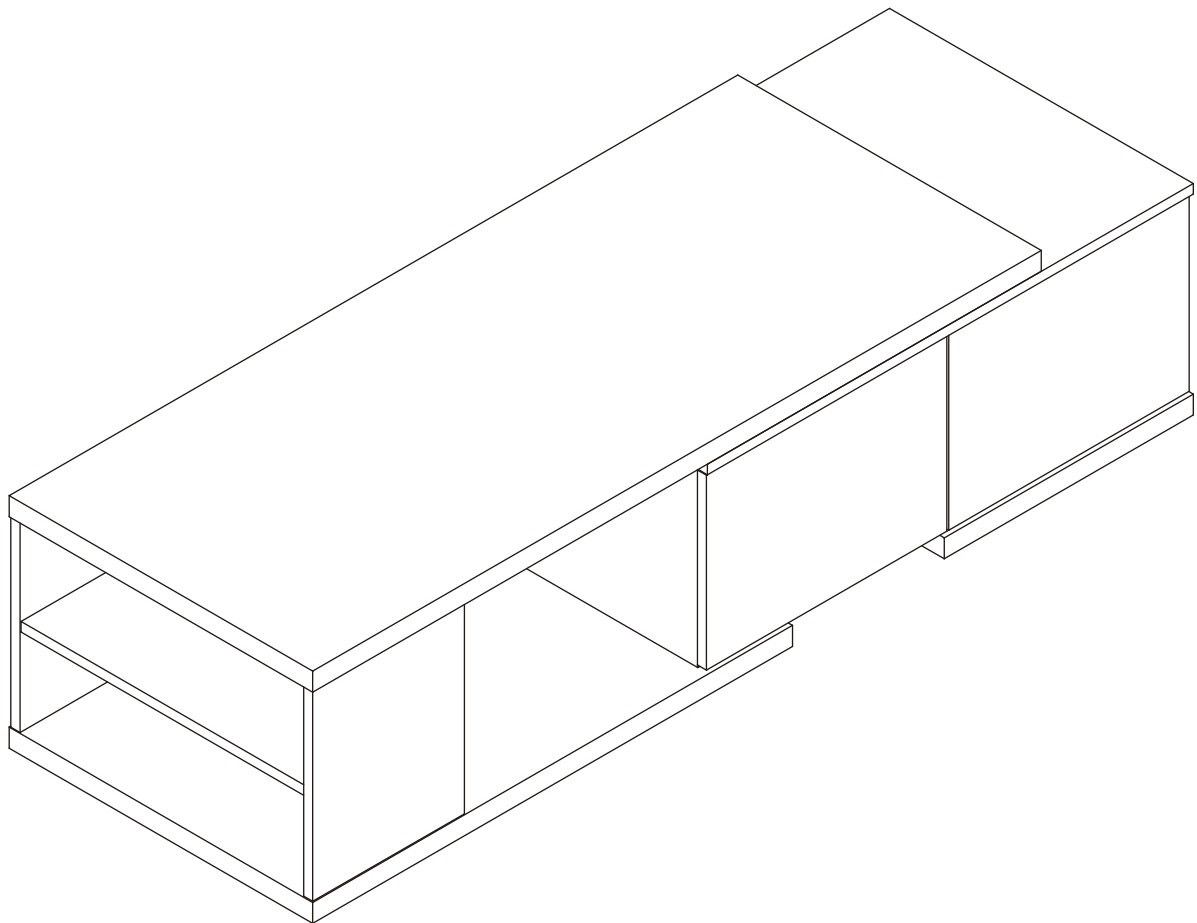

Dimensions

Width-47.2-57.1inch

Depth-19.7inch

Height-14.2inch

Important – Please read these instructions fully before starting assembly



Safety and Care Advice

Important – Please read these instructions fully before starting assembly

- Check you have all the components and tools listed on the following pages.
- Remove all fittings from the plastic bags and separate them into their groups.
- Keep children and animals away from the work area, small parts could choke if swallowed.
- Make sure you have enough space to layout the parts before starting.

- During assembly do not stand or put weight on the product, this could cause damage.
- Assemble the item as close to its final position (in the same room) as possible.
- Assemble on a soft level surface to avoid damaging the unit or your floor.
- Parts of the assembly will be easier with 2 people.



- To reduce the likelihood of damaging your product please ensure that your power drill is set on a low torque setting.

Care and maintenance

- Only clean using a damp cloth and mild detergent, do not use bleach or abrasive cleaners.
- From time to time check that there are no loose screws on this unit.
- This product should not be discarded with household waste. Take to your local authority waste disposal centre.

Handy Hints

- Assemble all parts and bolts loosely during assembly, only once the product is complete should you fully tighten the bolts
- Regularly check and ensure that all bolts and fittings are tightened properly.

WARNING
In order to help prevent overturning – please follow these instructions

To help prevent product toppling over please follow the below steps:-

- Use the anti tip stap or wall fixing method provided (if applicable)
- Do not allow children to climb or hang on the furniture
- Do not open more than one drawer at a time
- Do not place heavy items in the top drawers
- Do not place heavy items on top of the furniture, unless the furniture has been designed for this purpose

Using Camlocks

Step 1

Connect the male camlock as directed in the assembly instructions using a screwdriver.

1

DO NOT OVER TIGHTEN.
NE PAS SERRER EXCESSIVEMENT.

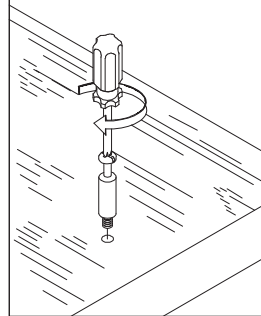

Step 2

Push the male camlock into the entry hole.

2

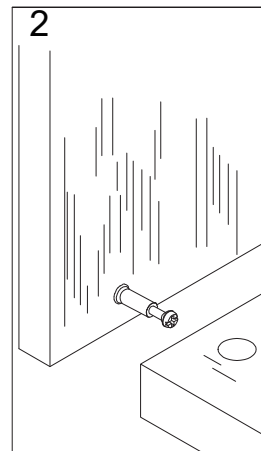

Step 3

Insert the female camlock as shown in the instruction.

Note: ensure that the arrow on the top of the camlock points towards the entry hole for the male camlock.

3

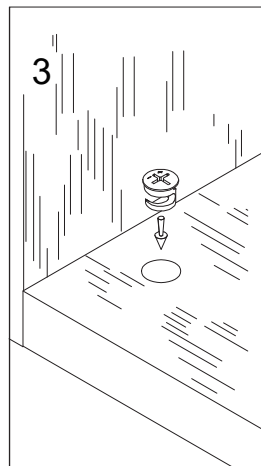

Step 4

Turn the female camlock clockwise with a screwdriver.

You should feel a click when the camlock is locked in place.

The joint is now secure.

4

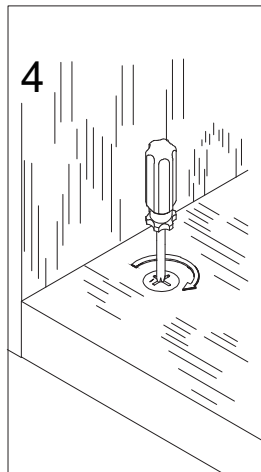

Assembly Instructions

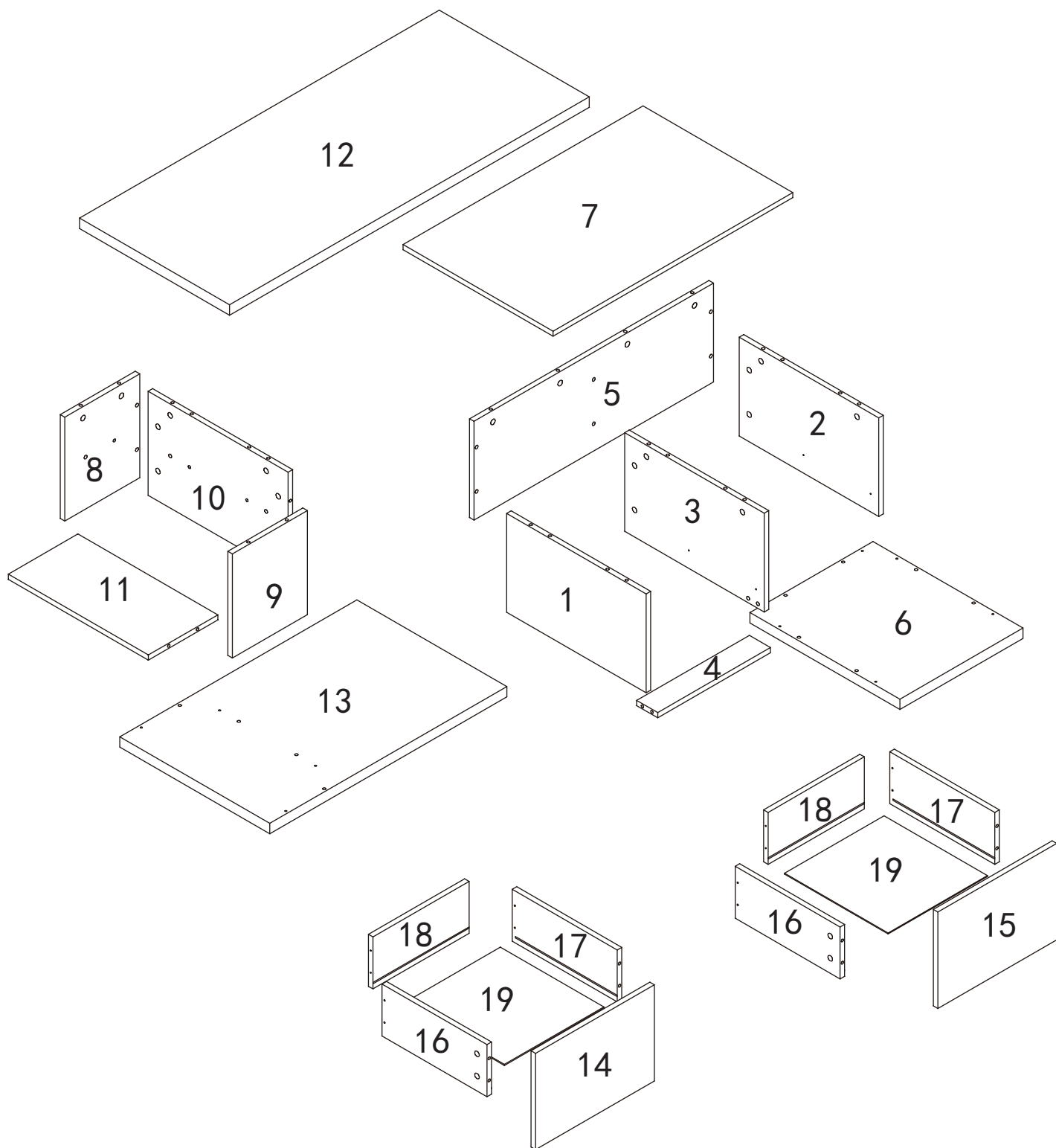

Assembly Instructions

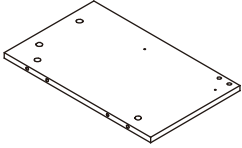
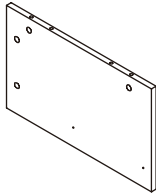
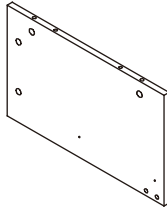
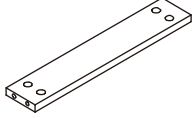
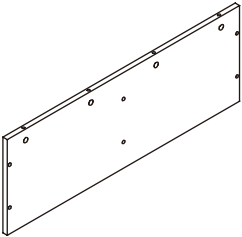
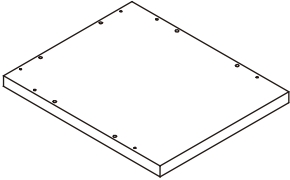
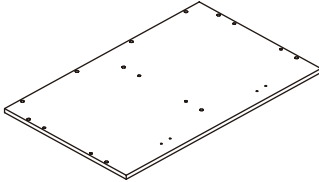
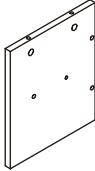
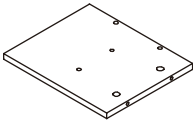
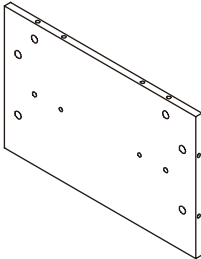
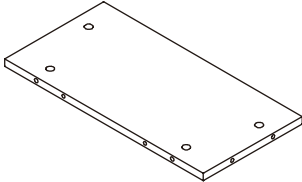
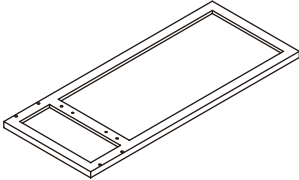
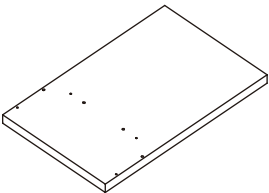
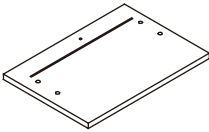
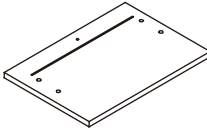
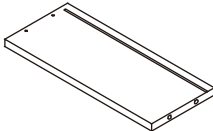
 285x465x15mm	 285x465x15mm	 285x465x15mm	 375.5x70x15mm
① x 1	② x 1	③ x 1	④ x 1
 796x285x15mm	 410x500x30mm	 800x500x15mm	 300x250x15mm
⑤ x 1	⑥ x 1	⑦ x 1	⑧ x 1
 300x250x15mm	 467x300x15mm	 467x232x15mm	 1200x500x30mm
⑨ x 1	⑩ x 1	⑪ x 1	⑫ x 1
 790x500x30mm	 396x278x15mm	 396x278x15mm	 350x150x15mm
⑬ x 1	⑭ x 1	⑮ x 1	⑯ x 2



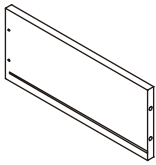
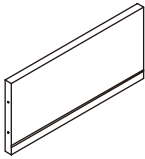
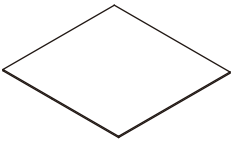



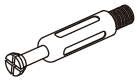

Assembly Instructions

			
350x150x15mm	320.5x150x15mm	331.5x345x3mm	
①7 x 2	①8 x 2	①9 x 2	

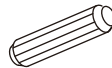
Components-Fittings

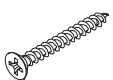
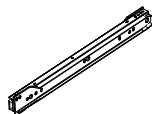
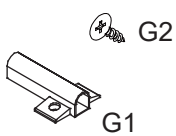
Please check you have all the panels listed below

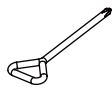

Note: The quantities below are the correct amount to complete the assembly. In some cases more fittings may be supplied than are required.

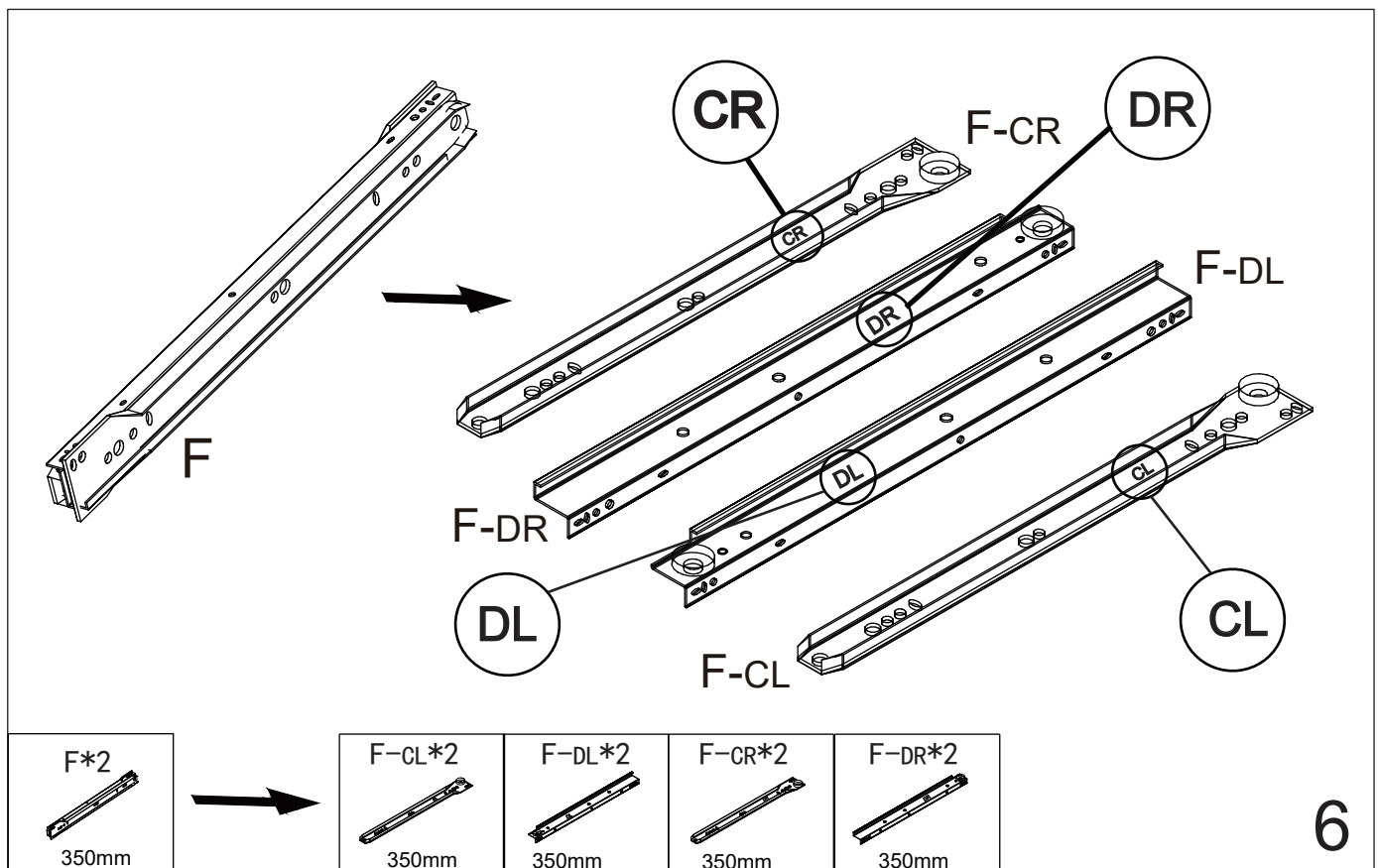
<p>(A)</p>  <p>Cam Bolt x 42+2</p>	<p>(B)</p>  <p>Cam Lock x 42+2</p>	<p>(C)</p>  <p>8*30mm Dowel x 22+2</p>	<p>(D)</p>  <p>5*60mm Screw x 10+1</p>
<p>(E)</p>  <p>3.5*35mm Screw x 8+1</p>	<p>(F)</p>  <p>350mm Drawer slide x 2</p>	<p>(G)</p>  <p>Rebound device x 2</p>	<p>(H)</p>  <p>3.5*14mm Screw x 20+2</p>
<p>(J)</p>  <p>felt x 10+2</p>	<p>(K)</p>  <p>Perfect sticker x 10</p>	<p>(L)</p>  <p>Screwdriver x 1</p>	



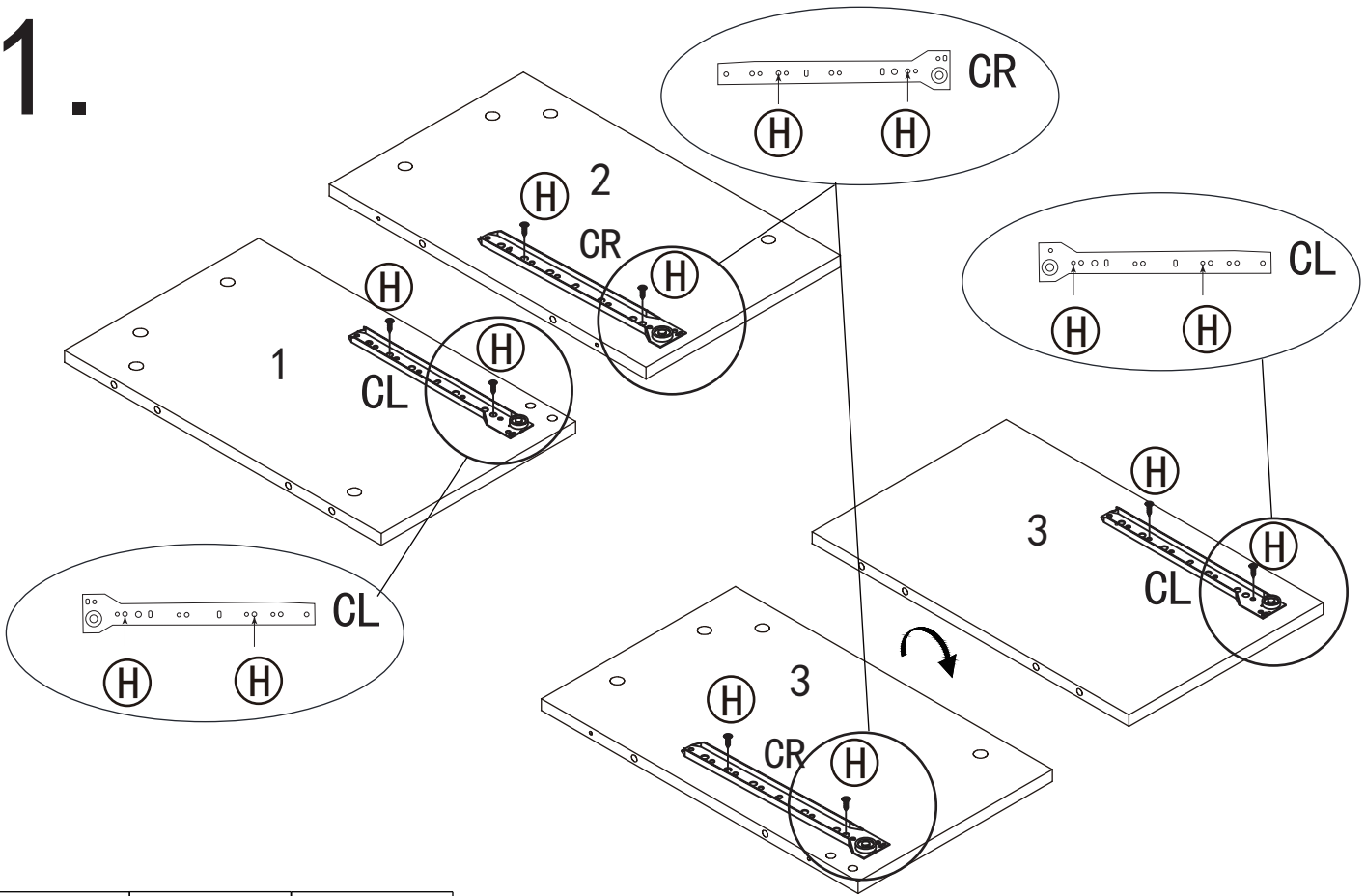



1.

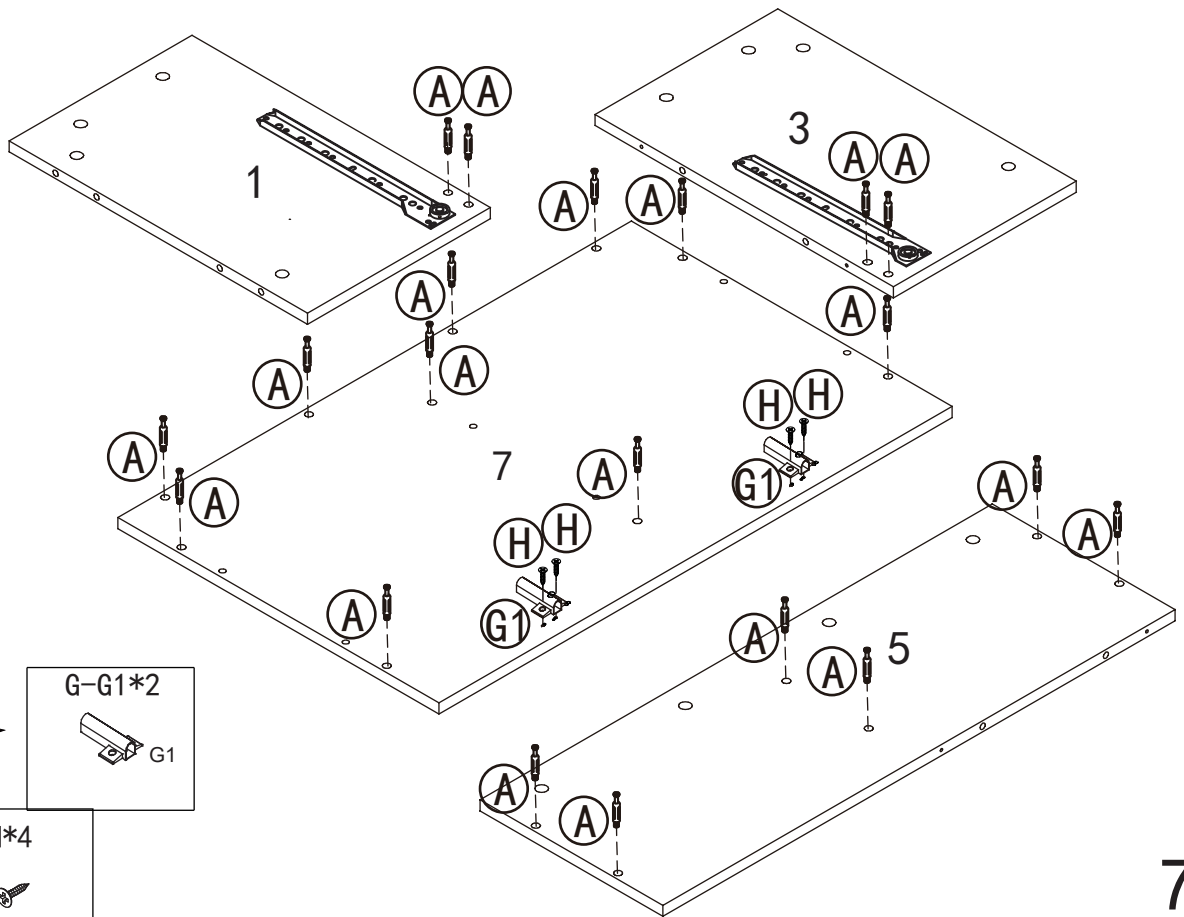

CL*2  350mm	CR*2  350mm	H*8  Ø3.5 x 14mm
---	--	---

2.



G*2  G1	G-G1*2  G1
A*20 	H*4  Ø3.5 x 14 mm

3.

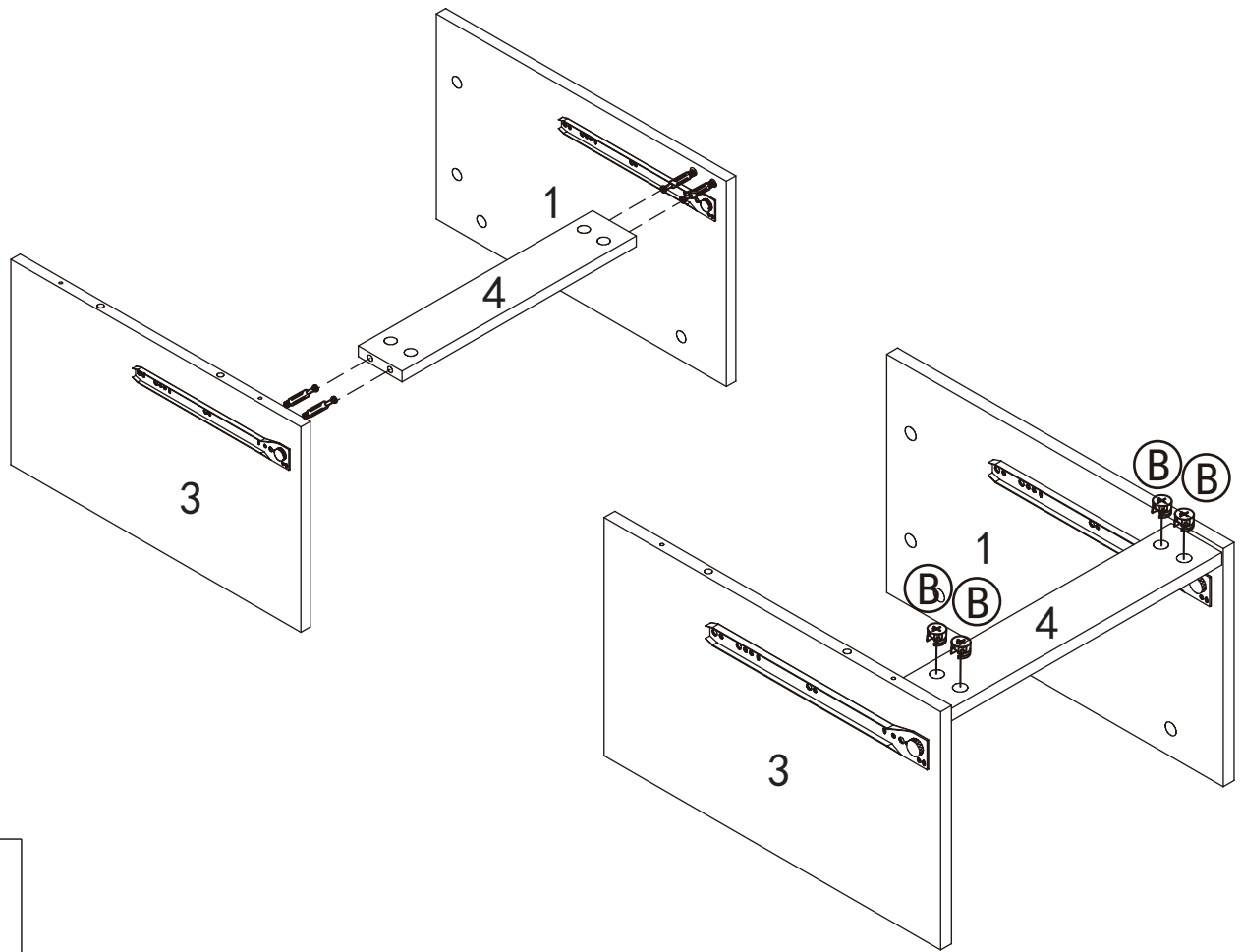

B*4



4.

The product should be flipped 180° before installing board 6

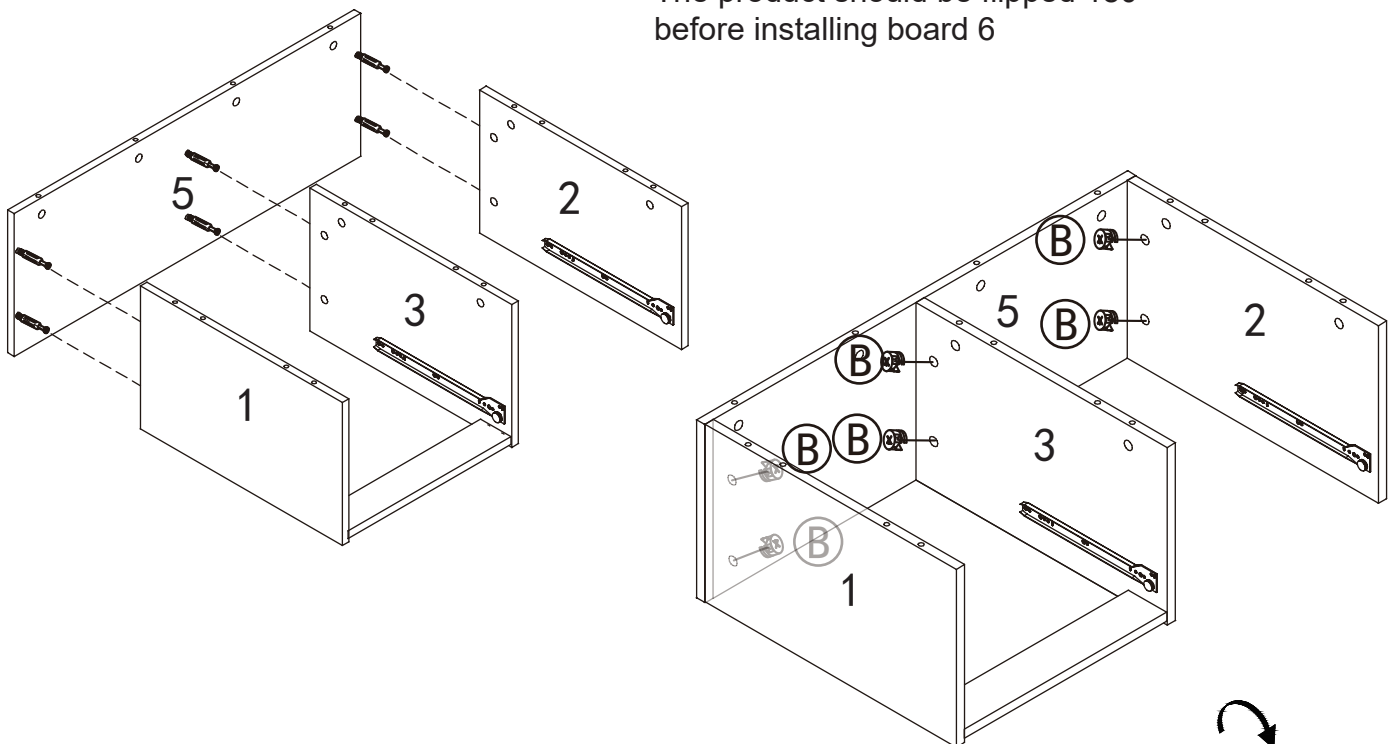



B*6



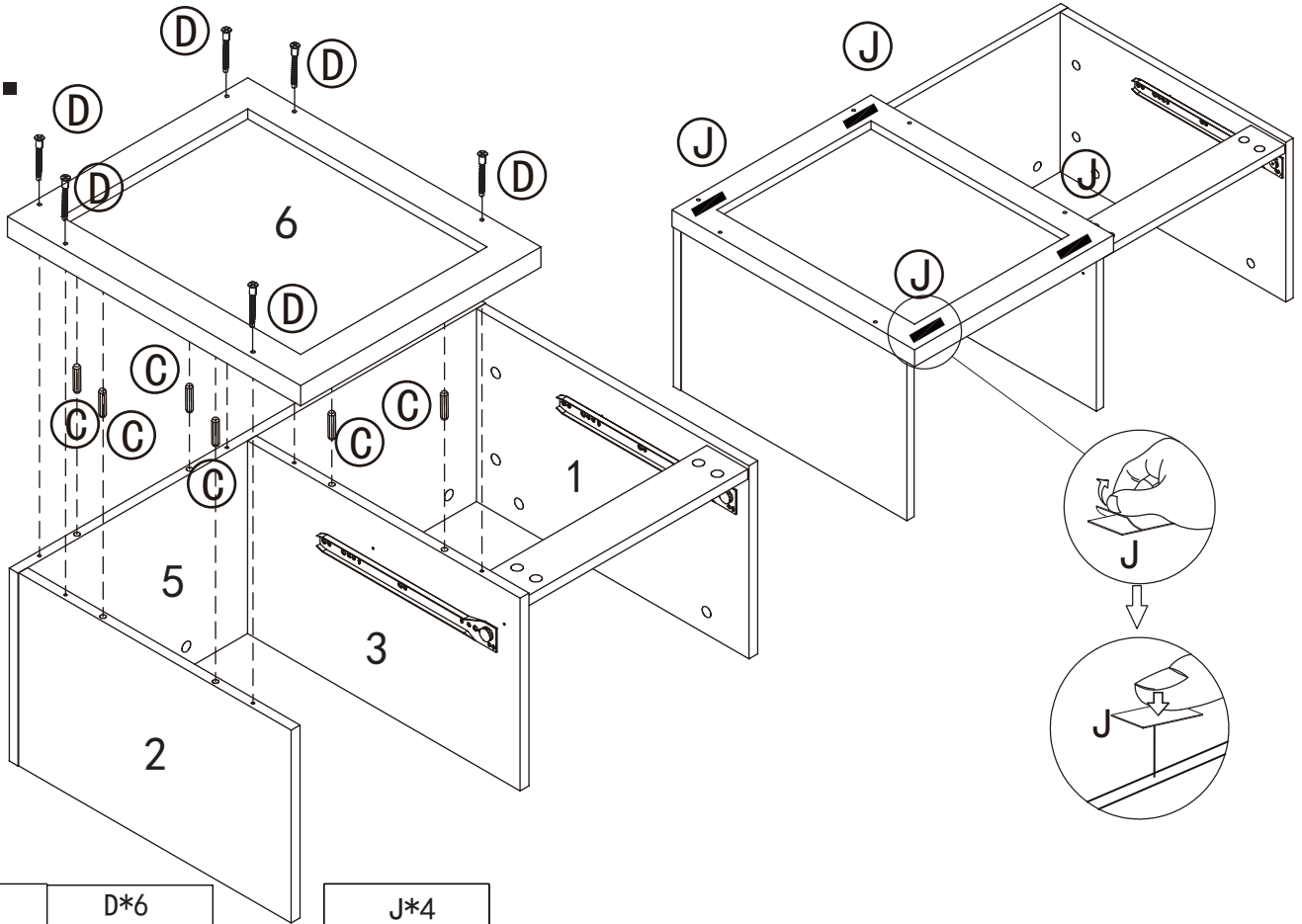

5.



C*6  ø8 x 30 mm	D*6  ø5 x 60 mm	J*4 
---	---	---

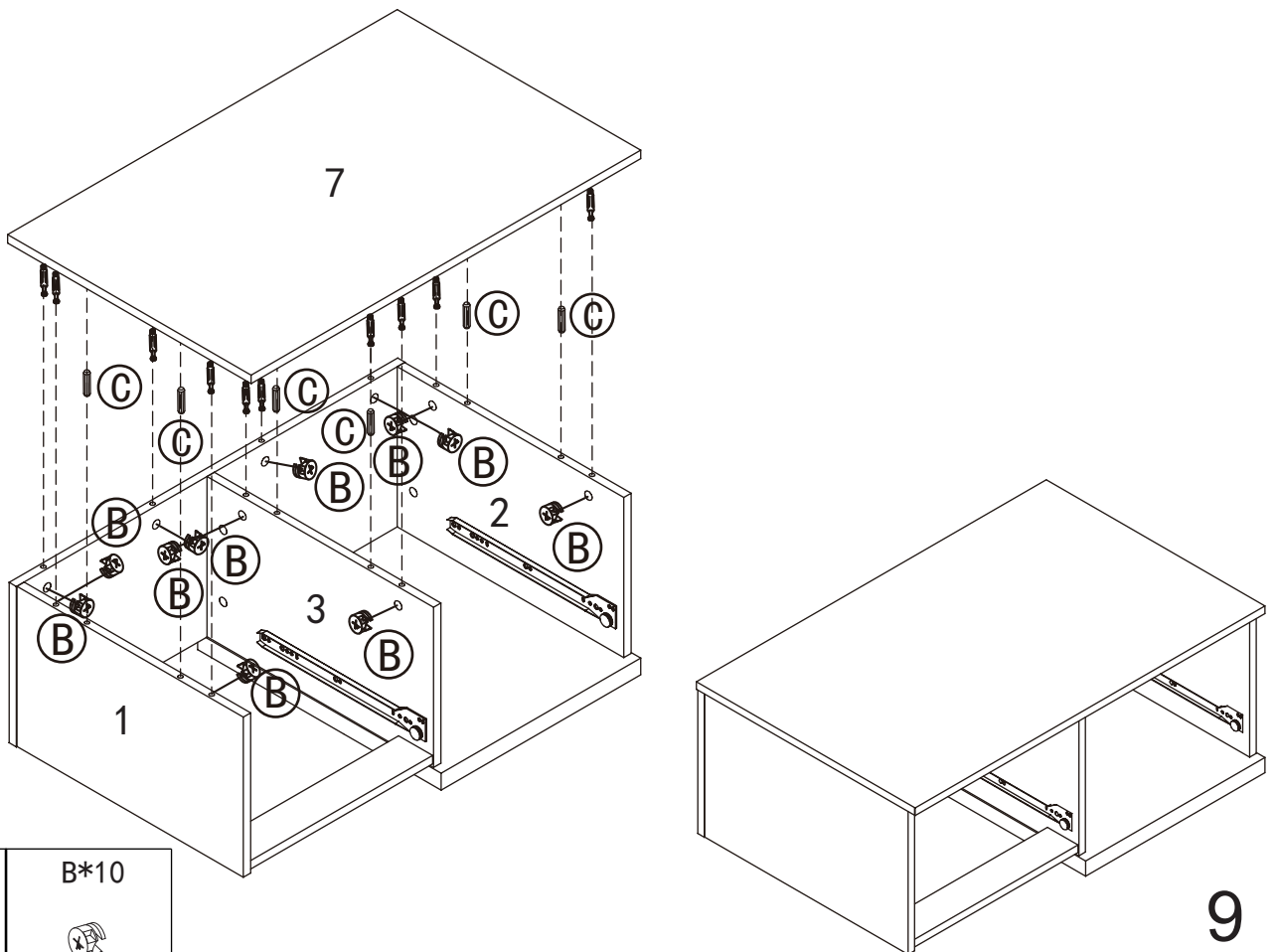

6.

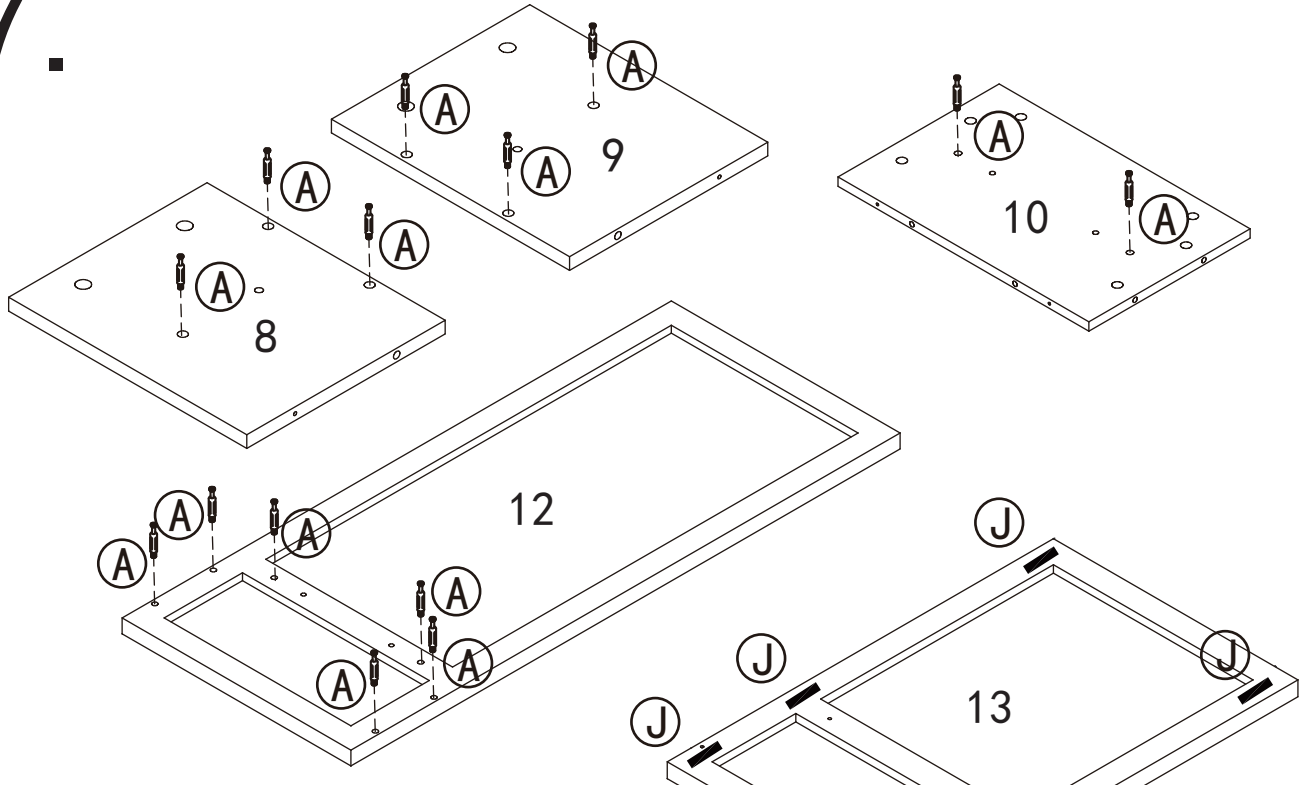

C*6  ø8 x 30 mm	B*10 
---	--

7.



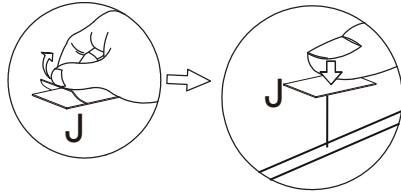

A*14	J*6
	



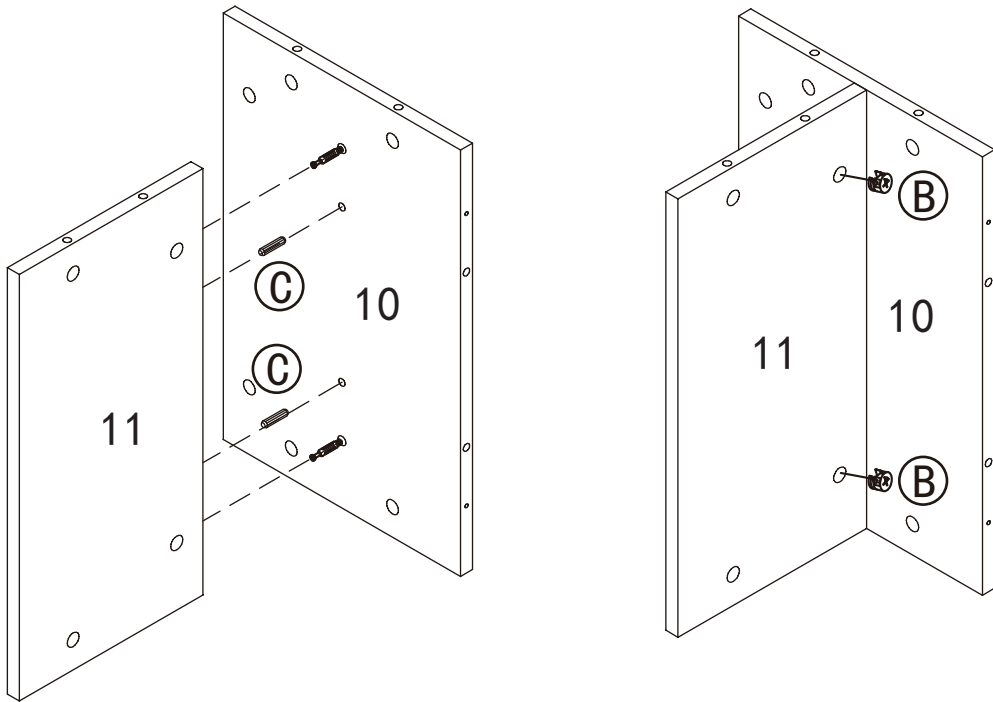

8.

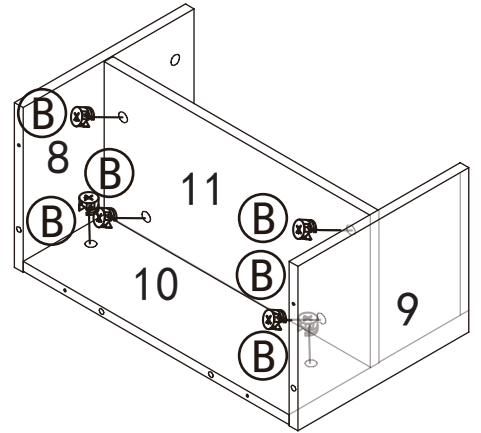
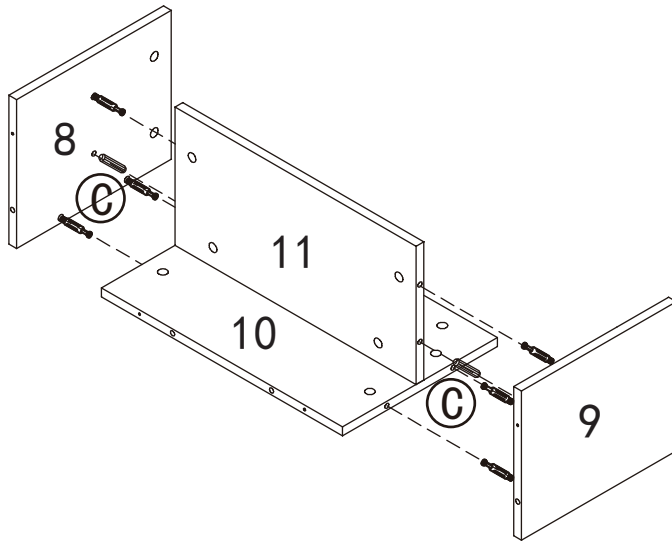

C*2	B*2
 ø8 x 30 mm	

9.





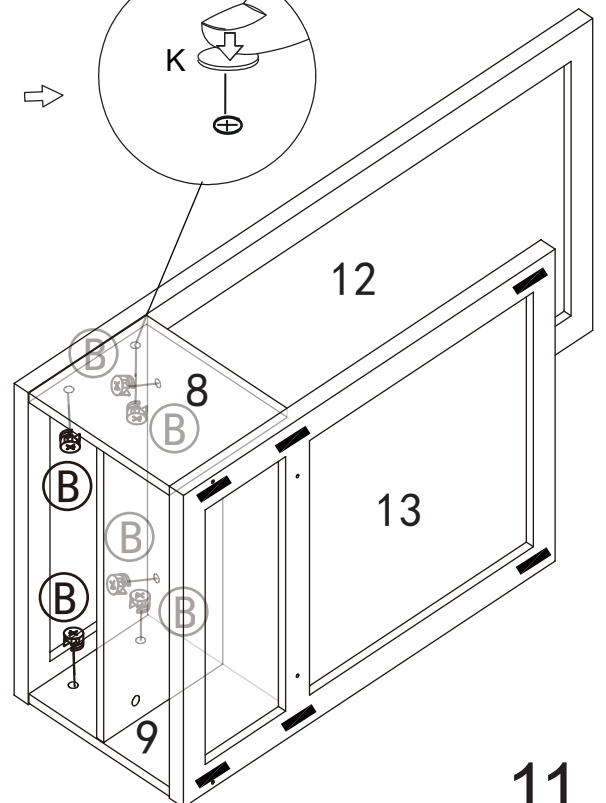
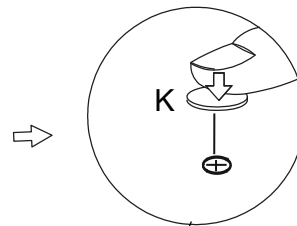
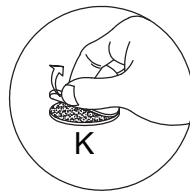
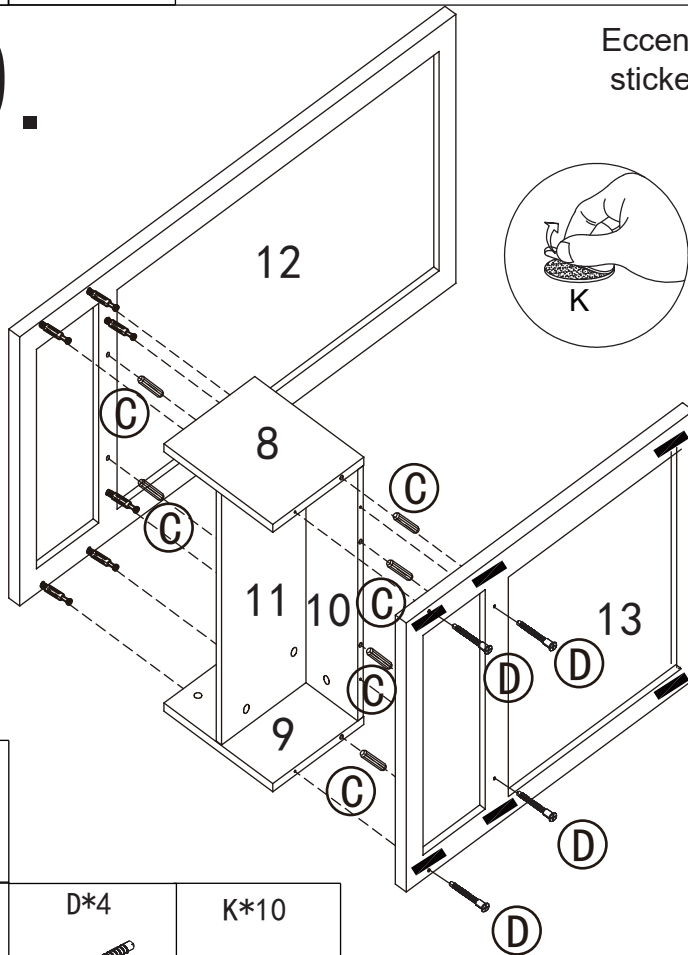

C*2  Ø8 x 30 mm	B*6 
--	--

10.

Eccentric wheel visible hole sticker perfectly fits K







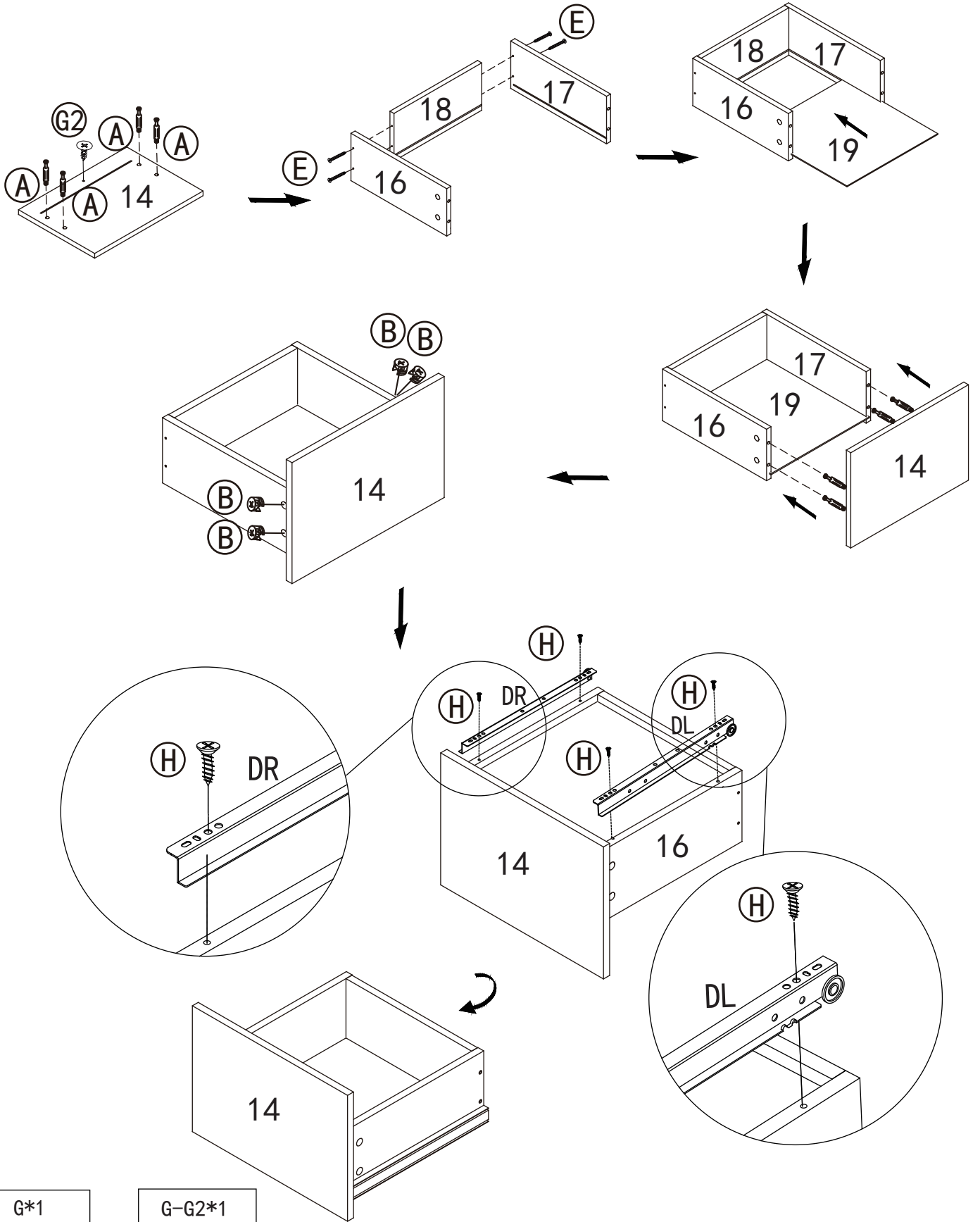

B*6 	D*4  Ø5 x 60 mm	K*10 
C*6  Ø8 x 30 mm		

11

11.



A*4	B*4	E*4	H*4	DL*1	DR*1
					
		Ø3.5 x 35 mm	Ø3.5 x 14 mm	350mm	350mm

12.

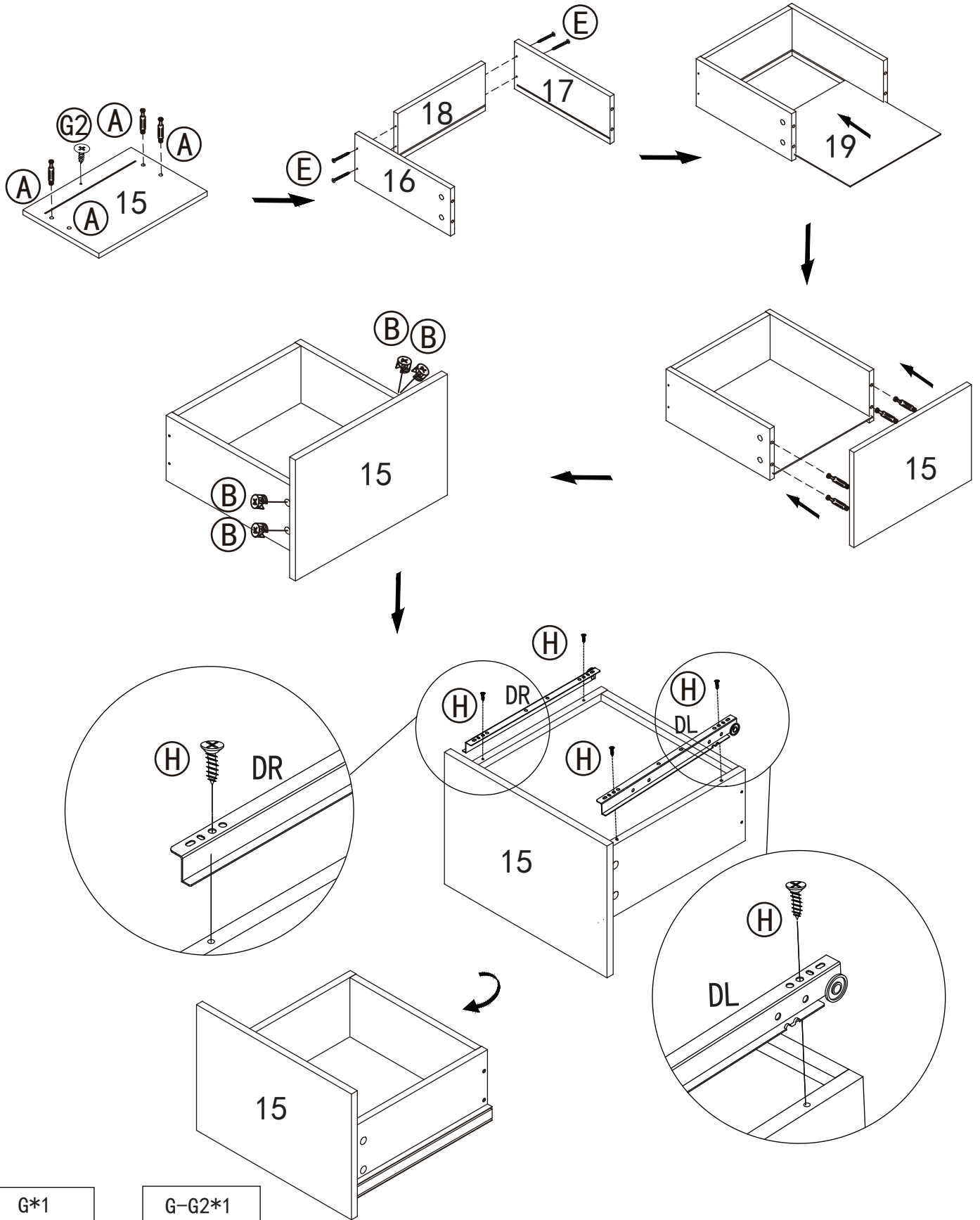

G*1 		G-G2*1 			
A*4 	B*4 	E*4 <small>Ø3.5 x 35 mm</small>	H*4 <small>Ø3.5 x 14 mm</small>	DL*1 <small>350mm</small>	DR*1 <small>350mm</small>

13.

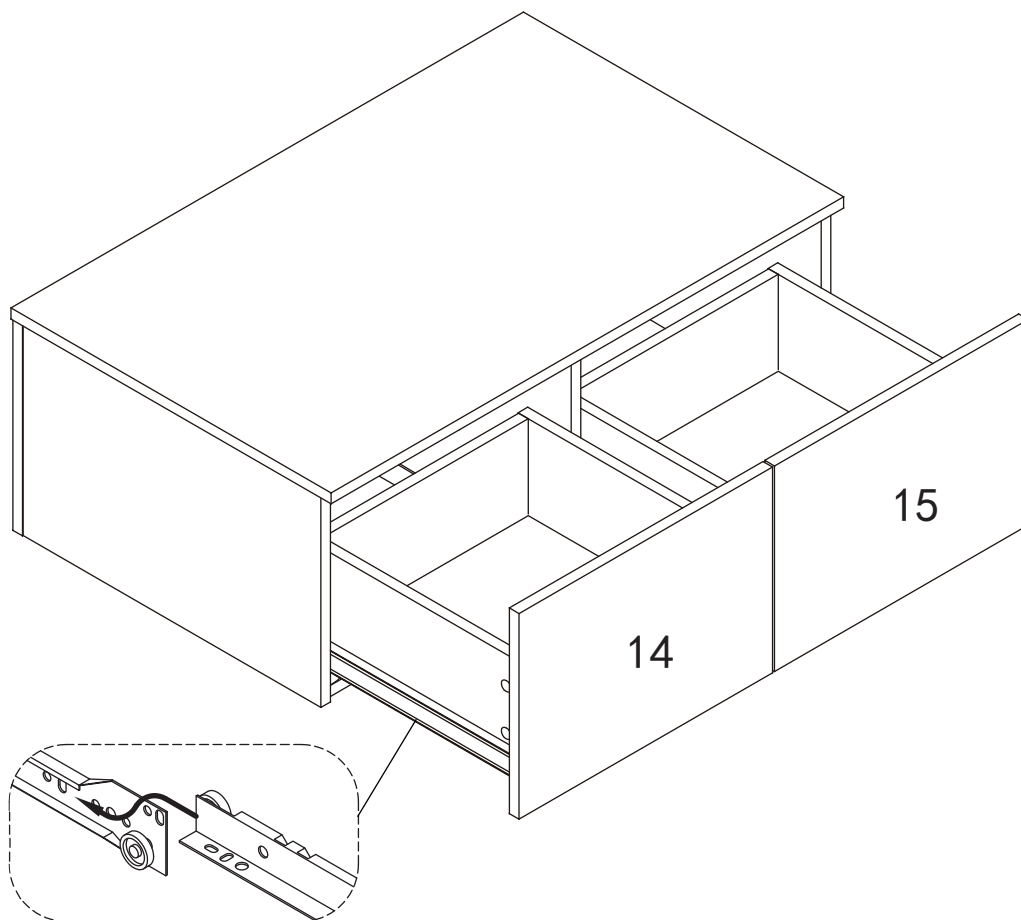

14.

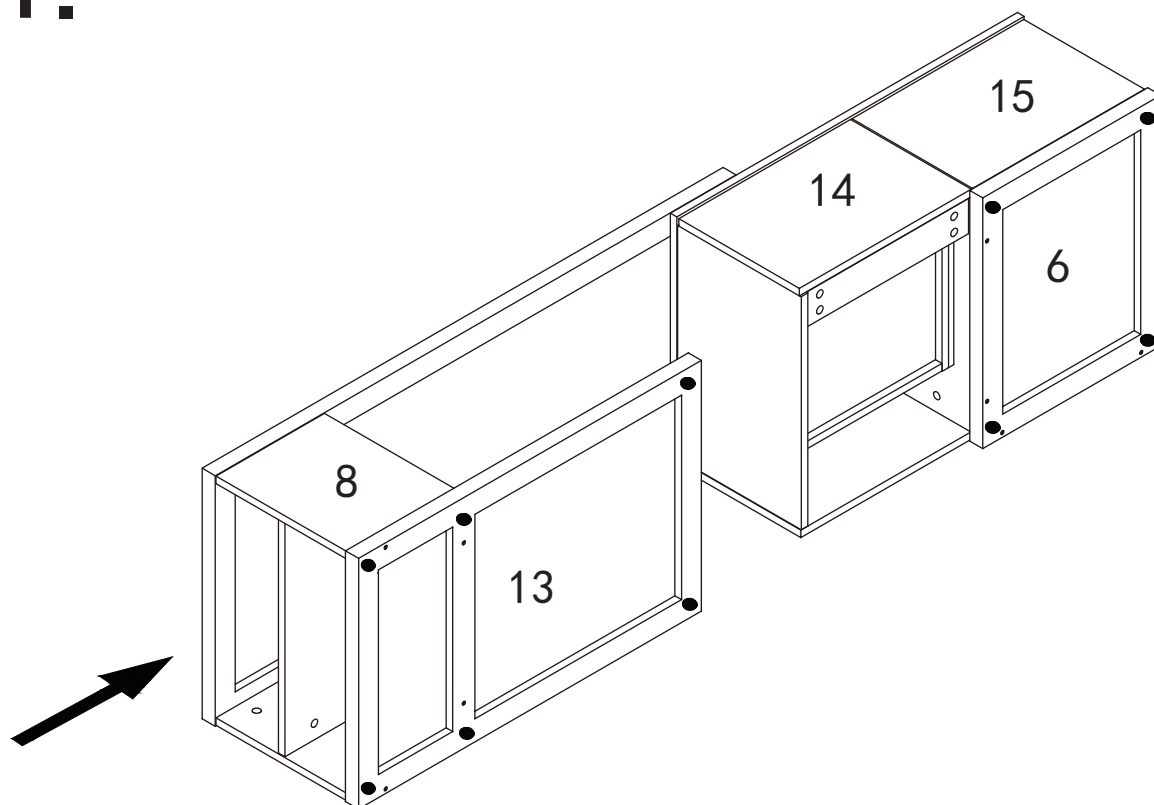

15.

