

Coffee Table

Assembly Instructions - Please keep for future reference

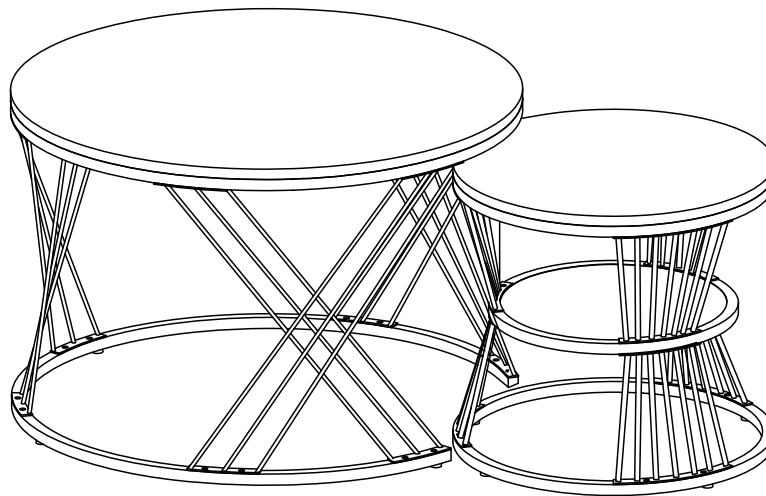

Dimensions

Width-27.56inch
Depth-27.56inch
Height-17.72inch

Dimensions

Width-17.72inch
Depth-17.72inch
Height-15.75inch

Important – Please read these instructions fully before starting assembly



Safety and Care Advice

Important – Please read these instructions fully before starting assembly

- Check you have all the components and tools listed on the following pages.
- Remove all fittings from the plastic bags and separate them into their groups.
- Keep children and animals away from the work area, small parts could choke if swallowed.
- Make sure you have enough space to layout the parts before starting.

- During assembly do not stand or put weight on the product, this could cause damage.
- Assemble the item as close to its final position (in the same room) as possible.
- Assemble on a soft level surface to avoid damaging the unit or your floor.
- Parts of the assembly will be easier with 2 people.



- To reduce the likelihood of damaging your product please ensure that your power drill is set on a low torque setting.

Care and maintenance

- Only clean using a damp cloth and mild detergent, do not use bleach or abrasive cleaners.
- From time to time check that there are no loose screws on this unit.
- This product should not be discarded with household waste. Take to your local authority waste disposal centre.

Handy Hints

- Assemble all parts and bolts loosely during assembly, only once the product is complete should you fully tighten the bolts
- Regularly check and ensure that all bolts and fittings are tightened properly.

WARNING
In order to help prevent overturning – please follow these instructions









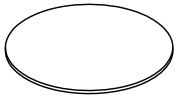
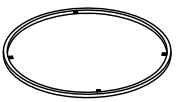

To help prevent product toppling over please follow the below steps:-

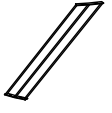
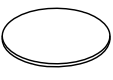
- Use the anti tip stap or wall fixing method provided (if applicable)
- Do not allow children to climb or hang on the furniture
- Do not open more than one drawer at a time
- Do not place heavy items in the top drawers
- Do not place heavy items on top of the furniture, unless the furniture has been designed for this purpose

Components - Fittings

Please check you have all the panels listed below

Note: The quantities below are the correct amount to complete the assembly. In some cases more fittings may be supplied than are required.

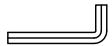
 27.58*27.58*0.59inch	 27.38*27.38*0.63inch	 19.71*6.27*3.94inch	 19.71*6.27*3.94inch
① X1PC	② X1PC	③ X3PCS	④ X3PCS
 17.73*17.73*0.59inch	 27.38*22.06*0.63inch	 8.47*6.69*1.57inch	 13.79*13.79*0.63inch
⑤ X1PC	⑥ X1PC	⑦ X6PCS	⑧ X1PC
 17.53*17.53*0.63inch	 17.53*17.53*0.63inch		
⑨ X1PC	⑩ X1PC		
A 	B 	C 	
6*10mm Screw x 56	Foot x 8	M4 Allen Key x 1	

Tools required



Hexagon wrench

Assembly Instructions

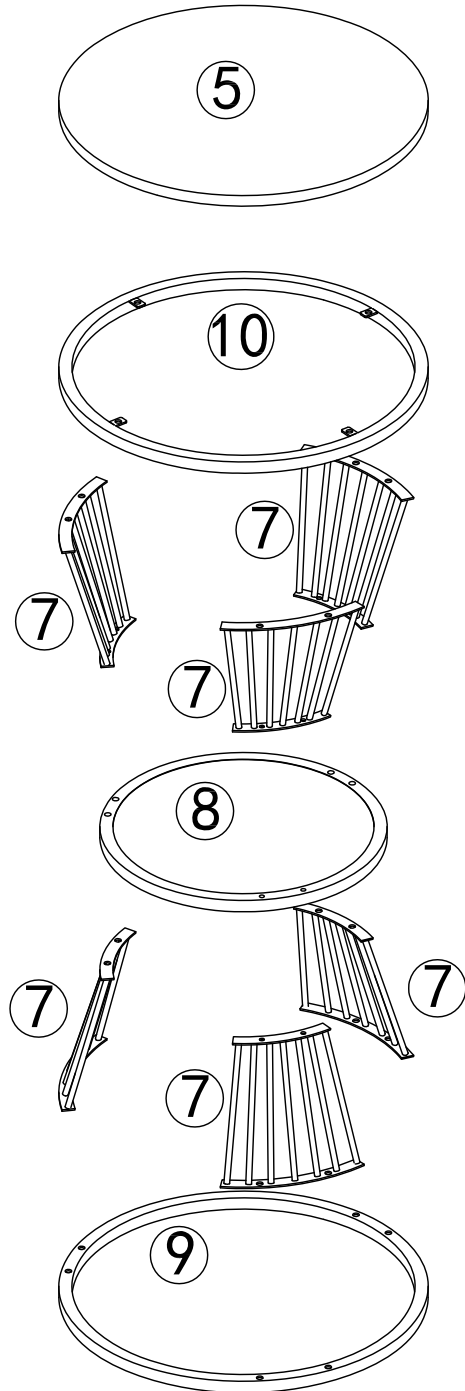
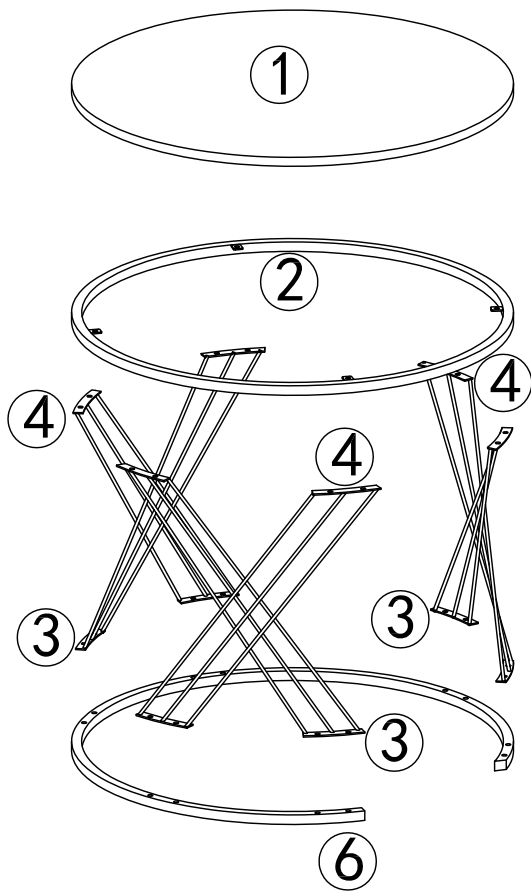

Assembly Instructions

Step 1

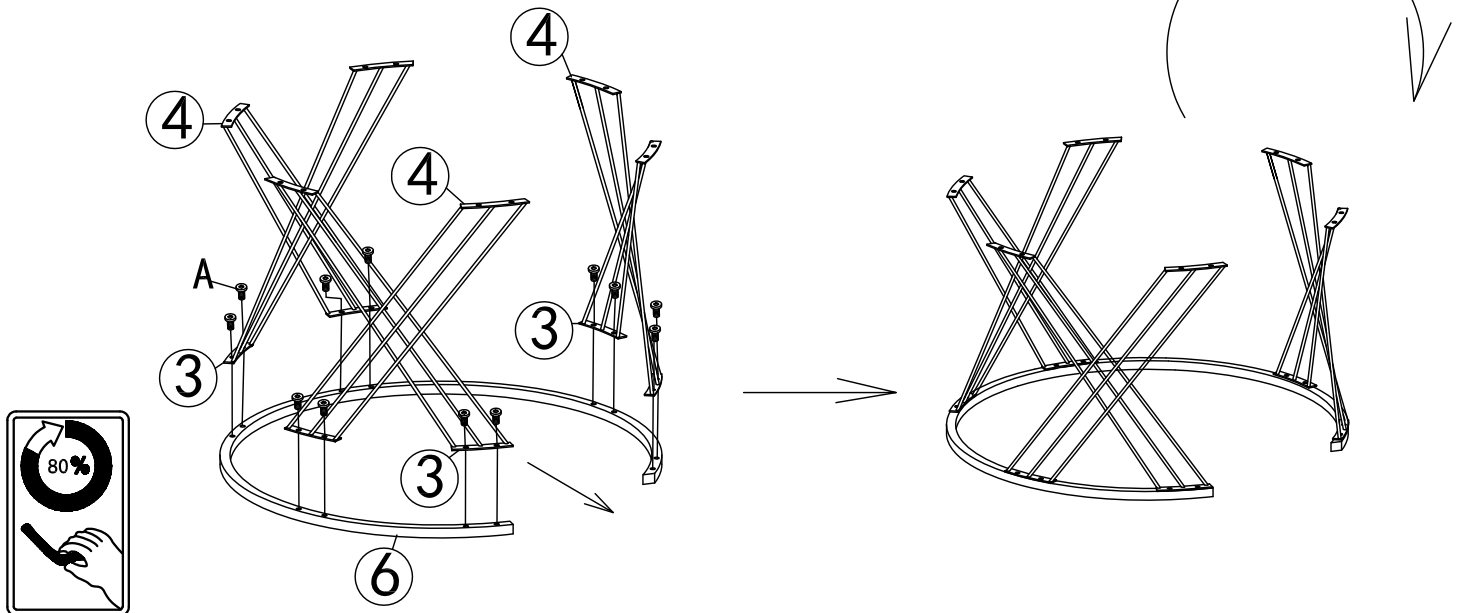

A



6*10mm Screw x 12

Step 2

Please rotate to the exact position for assembly

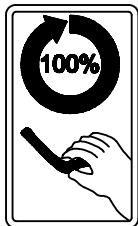
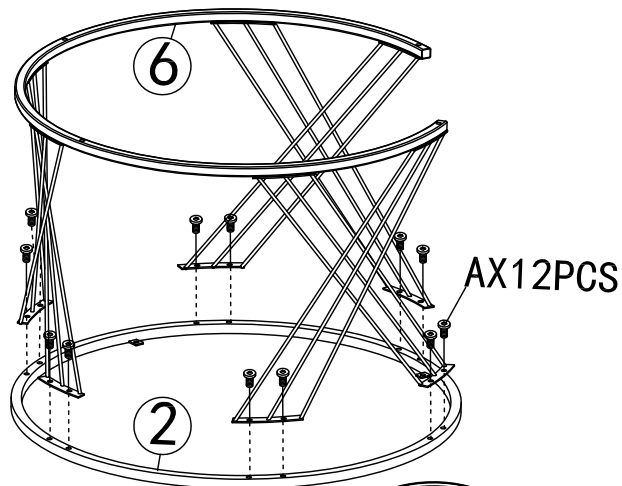

A



6*10mm Screw x 12

During the assembly process, if it is found that the hole positions in Figure 2 cannot be matched, the iron frame needs to be rotated until all the hole positions can be matched as shown in Figure 1 before assembly

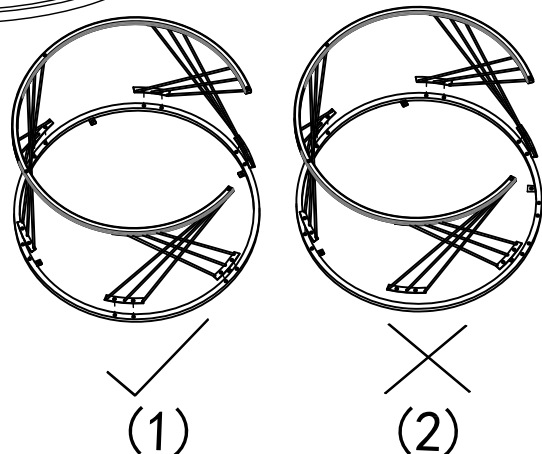

Assembly Instructions

Step 3

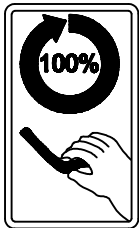
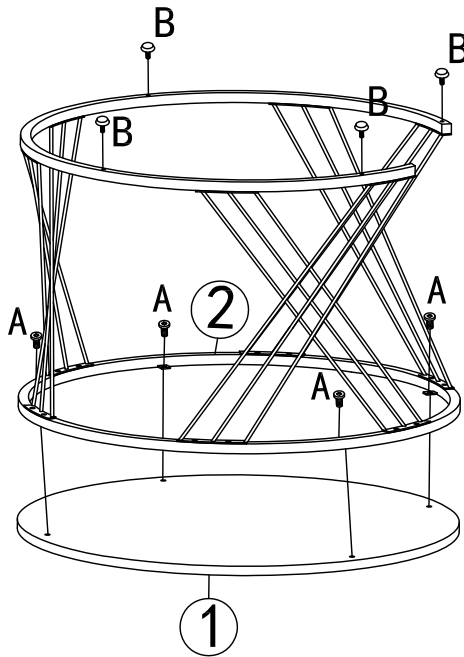

Attention! Pad the bottom with polystyrene to avoid scratches

A



6*10mm Screw x 4

B



Foot x 4

Step 4

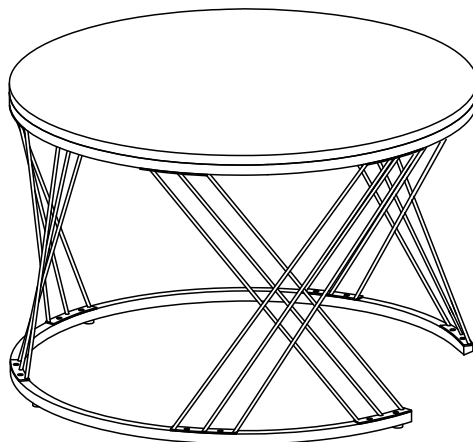

Assembly Instructions

Step 5

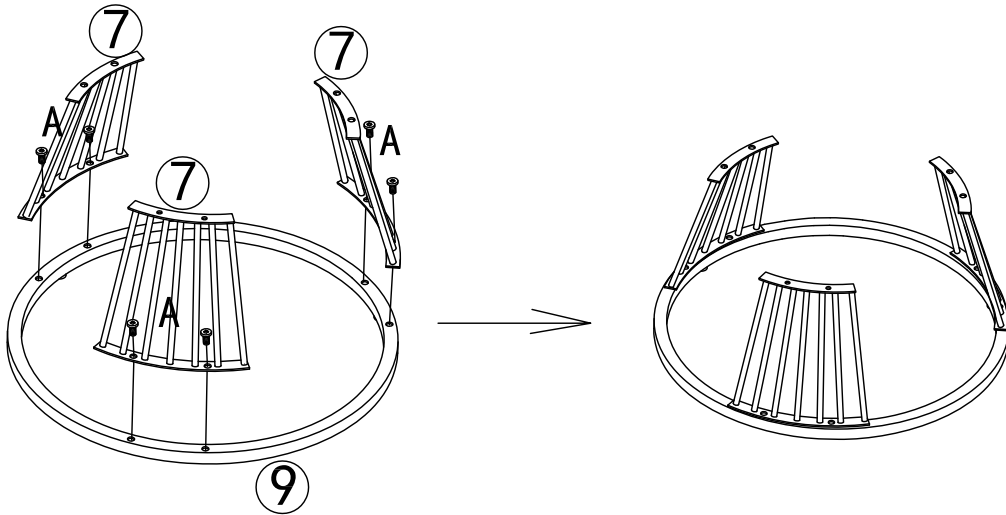
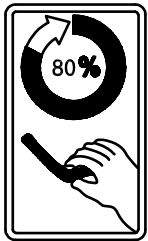

A



6*10mm Screw x 6

Step 6

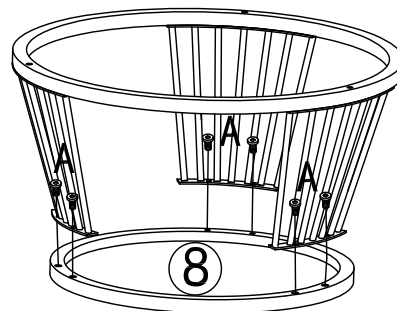
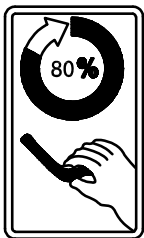

A



6*10mm Screw x 6

The finished product assembled in step 5 needs to be turned 180 degrees and fixed to part 8 with screw A

Assembly Instructions

Step 7

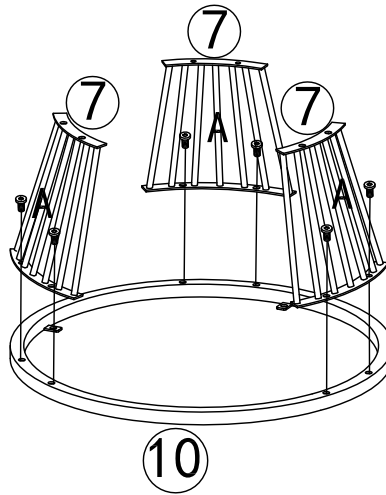
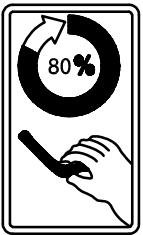

A



6*10mm Screw x 6

Step 8

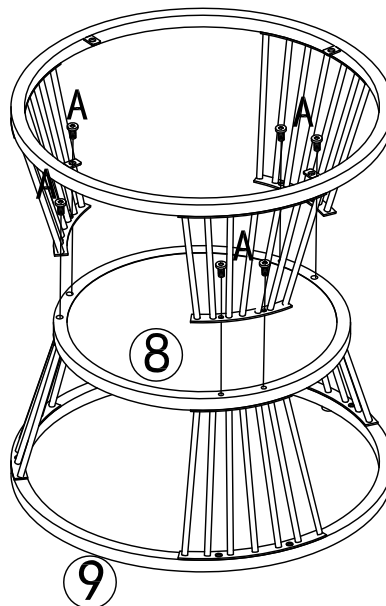
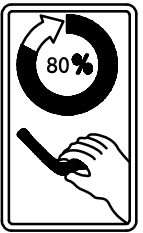

A



6*10mm Screw x 6

Assembly Instructions

Step 9

Attention! Pad the bottom with polystyrene to avoid scratches

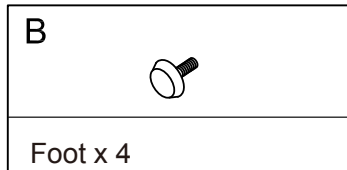
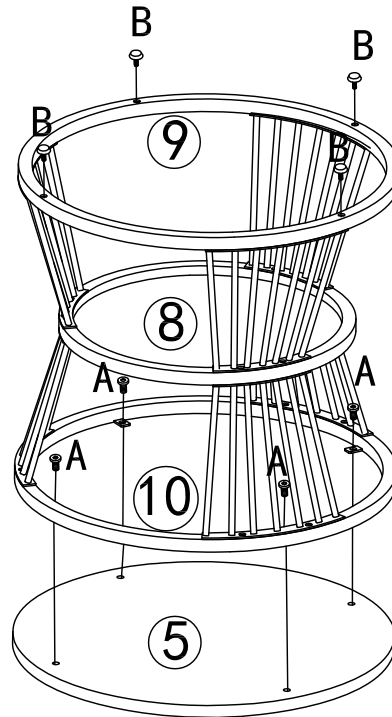
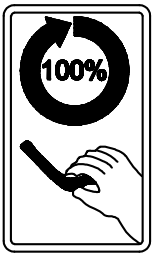

Step 10

