

Coffee Table

Assembly Instructions - Please keep for future reference

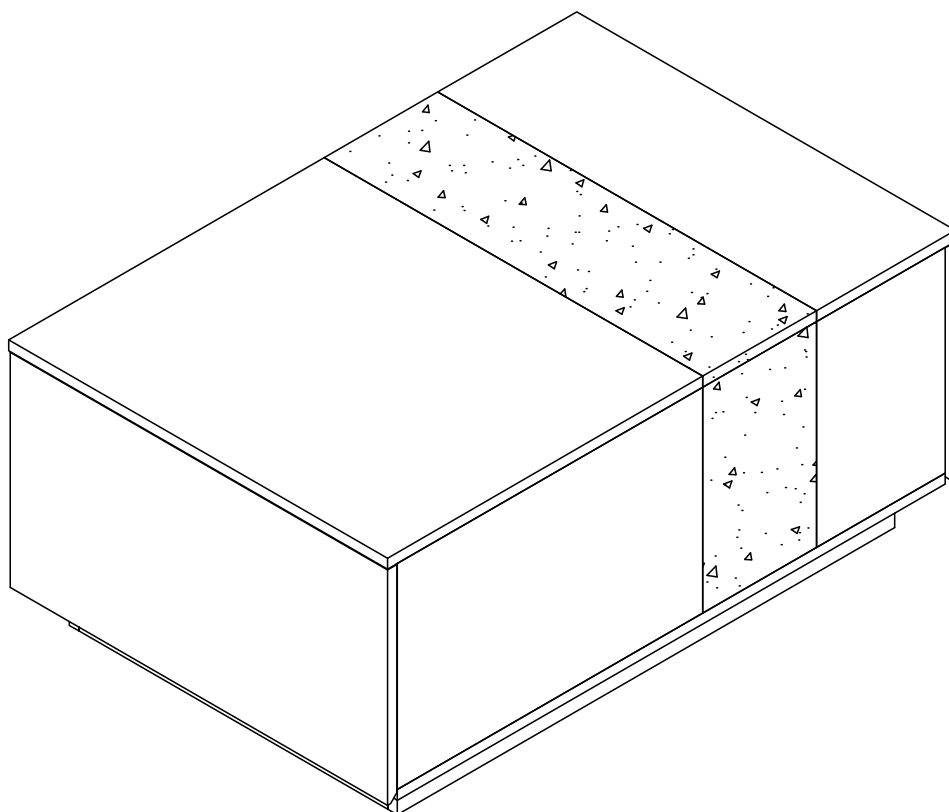

Dimensions

Width-35.43inch

Depth-23.62inch

Height-15.75inch

Important – Please read these instructions fully before starting assembly



Safety and Care Advice

Important – Please read these instructions fully before starting assembly

- Check you have all the components and tools listed on the following pages.
- Remove all fittings from the plastic bags and separate them into their groups.
- Keep children and animals away from the work area, small parts could choke if swallowed.
- Make sure you have enough space to layout the parts before starting.

- During assembly do not stand or put weight on the product, this could cause damage.
- Assemble the item as close to its final position (in the same room) as possible.
- Assemble on a soft level surface to avoid damaging the unit or your floor.
- Parts of the assembly will be easier with 2 people.



power drill is set on a low torque setting.

- To reduce the likelihood of damaging your product please ensure that your

Care and maintenance

- Only clean using a damp cloth and mild detergent, do not use bleach or abrasive cleaners.

- From time to time check that there are no loose screws on this unit.

- This product should not be discarded with household waste. Take to your local authority waste disposal centre.

Handy Hints

- Assemble all parts and bolts loosely during assembly, only once the product is complete should you fully tighten the bolts

- Regularly check and ensure That all bolts and fittings are tightend properly.

WARNING
In order to help prevent overturning –
please follow these instructions







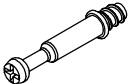

To help prevent product toppling over please follow the below steps:-

- Use the anti tip stap or wall fixing method provided (if applicable)
- Do not allow children to climb or hang on the furniture
- Do not open more than one drawer at a time
- Do not place heavy items in the top drawers
- Do not place heavy items on top of the furniture, unless the furniture has been designed for this purpose

Components - Fittings

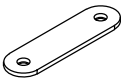
Please check you have all the panels listed below

Note: The quantities below are the correct amount to complete the assembly. In some cases more fittings may be supplied than are required.

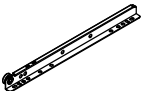
<p>(A) </p> <p>Cam Bolt x 38+3</p>	<p>(B) </p> <p>Cam lock x 38+3</p>	<p>(C) </p> <p>Dowel x 50+3</p>	<p>(D) </p> <p>4*35mm Screw x 24+2</p>
<p>(E) </p> <p>Iron sheet x 8</p>	<p>(F) </p> <p>3.5*12mm Screw x 32+3</p>	<p>(CL) </p> <p>300mm runner x 2</p>	<p>(CR) </p> <p>300mm runner x 2</p>
<p>(DL) </p> <p>300mm runner x 2</p>	<p>(DR) </p> <p>300mm runner x 2</p>		

Tools required

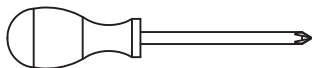
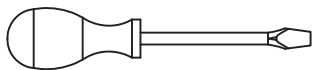

Phillips screwdriver
(medium & large)

Using Camlocks

Step 1

Connect the male camlock as directed in the assembly instructions using a screwdriver.

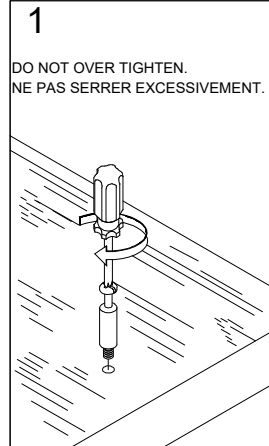

Step 2

Push the male camlock into the entry hole.

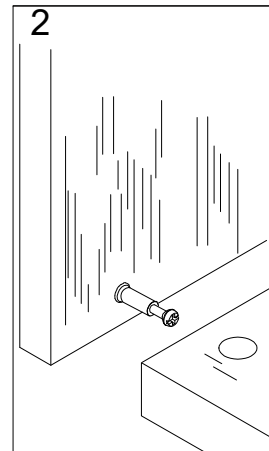

Step 3

Insert the female camlock as shown in the instruction.

Note: ensure that the arrow on the top of the camlock points towards the entry hole for the male camlock.

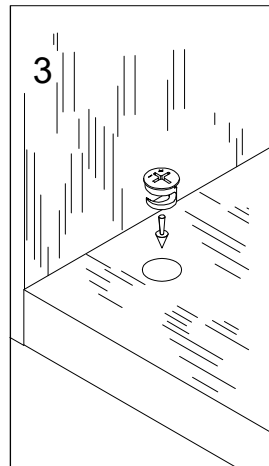

Step 4

Turn the female camlock clockwise with a screwdriver.

You should feel a click when the camlock is locked in place.

The joint is now secure.

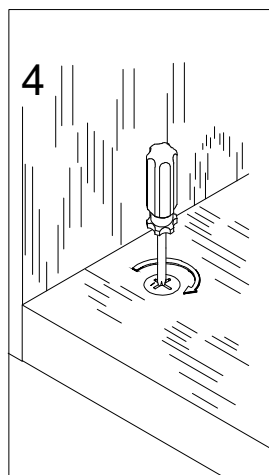

Assembly Instructions

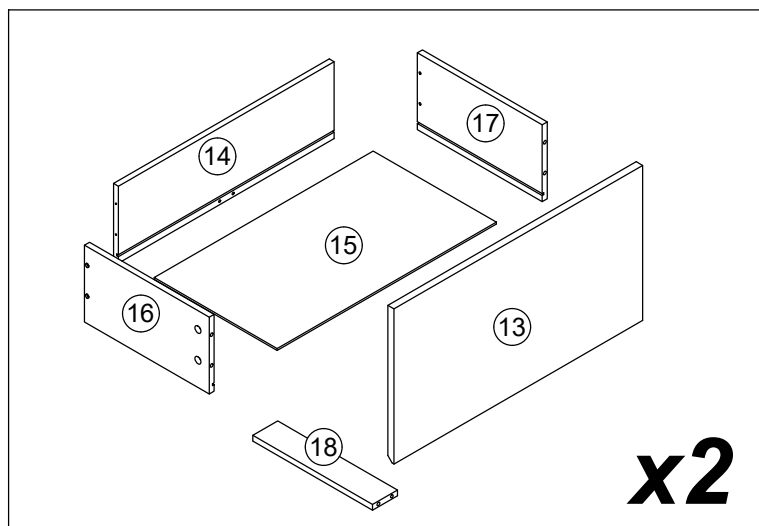
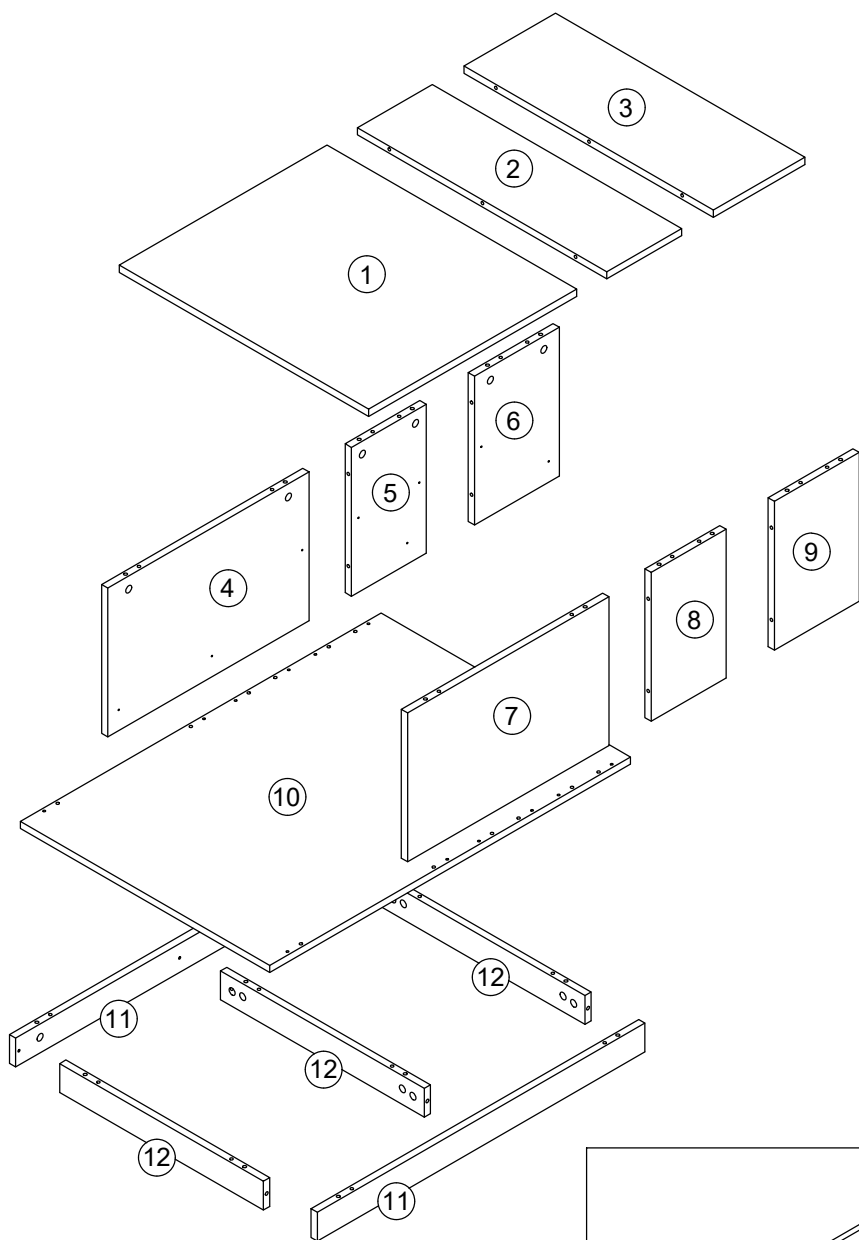

PART LIST

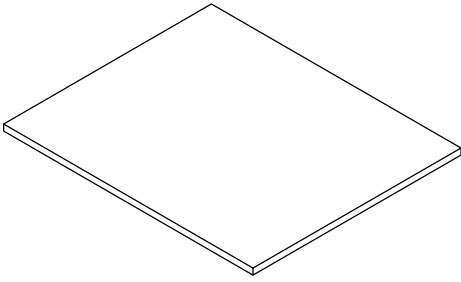

① X1

Panel
500x600x15mm

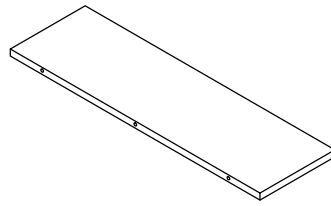

② X1

Panel
180x600x15mm

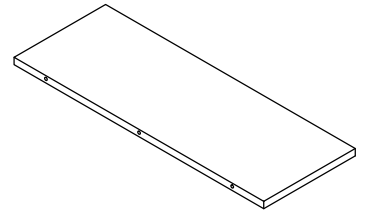

③ X1

Panel
220x600x15mm

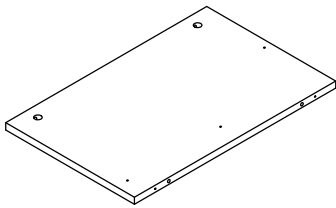

④ X1

Side panel
310x484x15mm

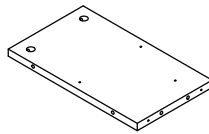

⑤ X1

Side panel
310x180x15mm

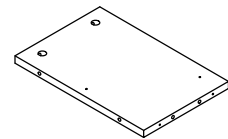

⑥ X1

Side panel
310x204x15mm

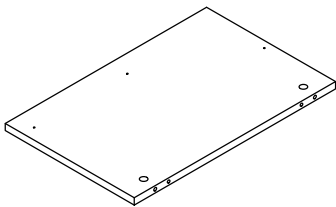

⑦ X1

Side panel
310x484x15mm

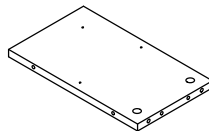

⑧ X1

Side panel
310x180x15mm

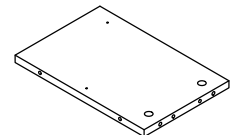

⑨ X1

Side panel
310x204x15mm

PART LIST

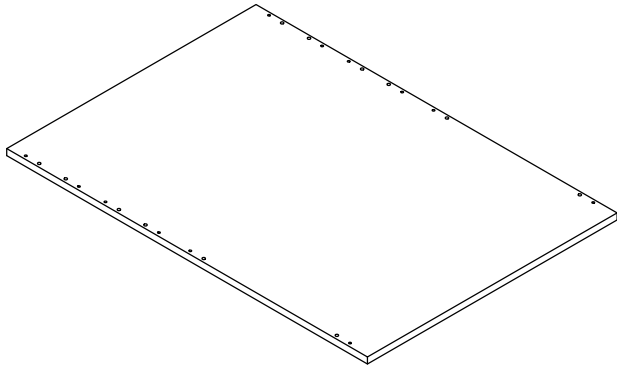

⑩ X1

Floor
868x600x15mm

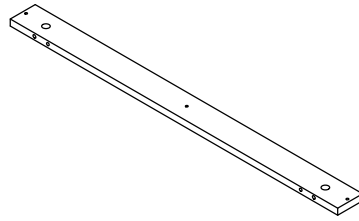

⑪ X2

Long footed base
788x60x15mm

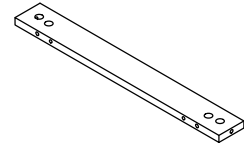

⑫ X3

Short footed base
490x60x15mm

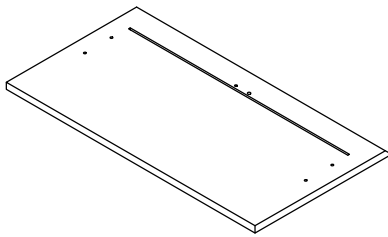

⑬ X2

Drawer panel
598x323x15mm

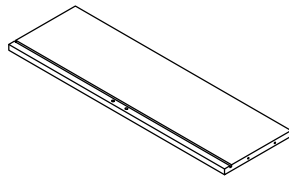

⑭ X2

Drawer back panel
519x160x12mm

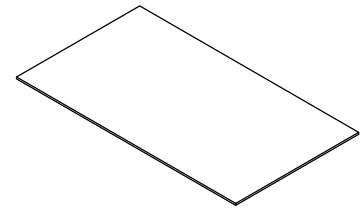

⑮ X2

Drawer bottom plate
528x297x3mm

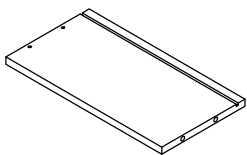

⑯ X2

Drawer side panel
300x160x12mm

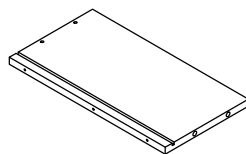

⑰ X2

Drawer side panel
300x160x12mm

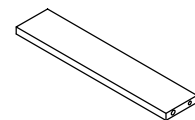

⑱ X2

Drawer bottom plate
288x60x15mm

Assembly Instructions

Step 1

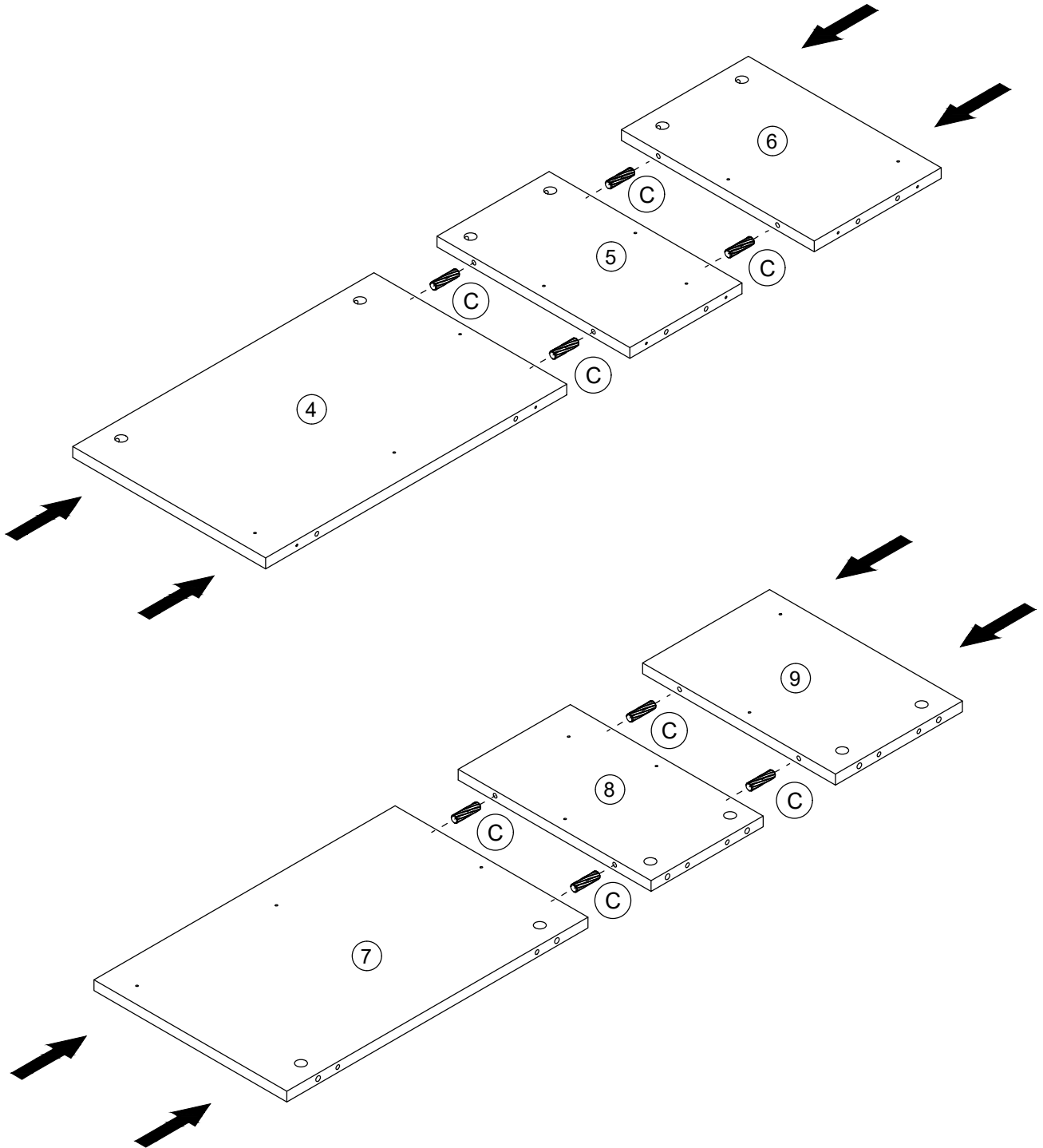

C



Dowel x 8

Assembly Instructions

Step 2

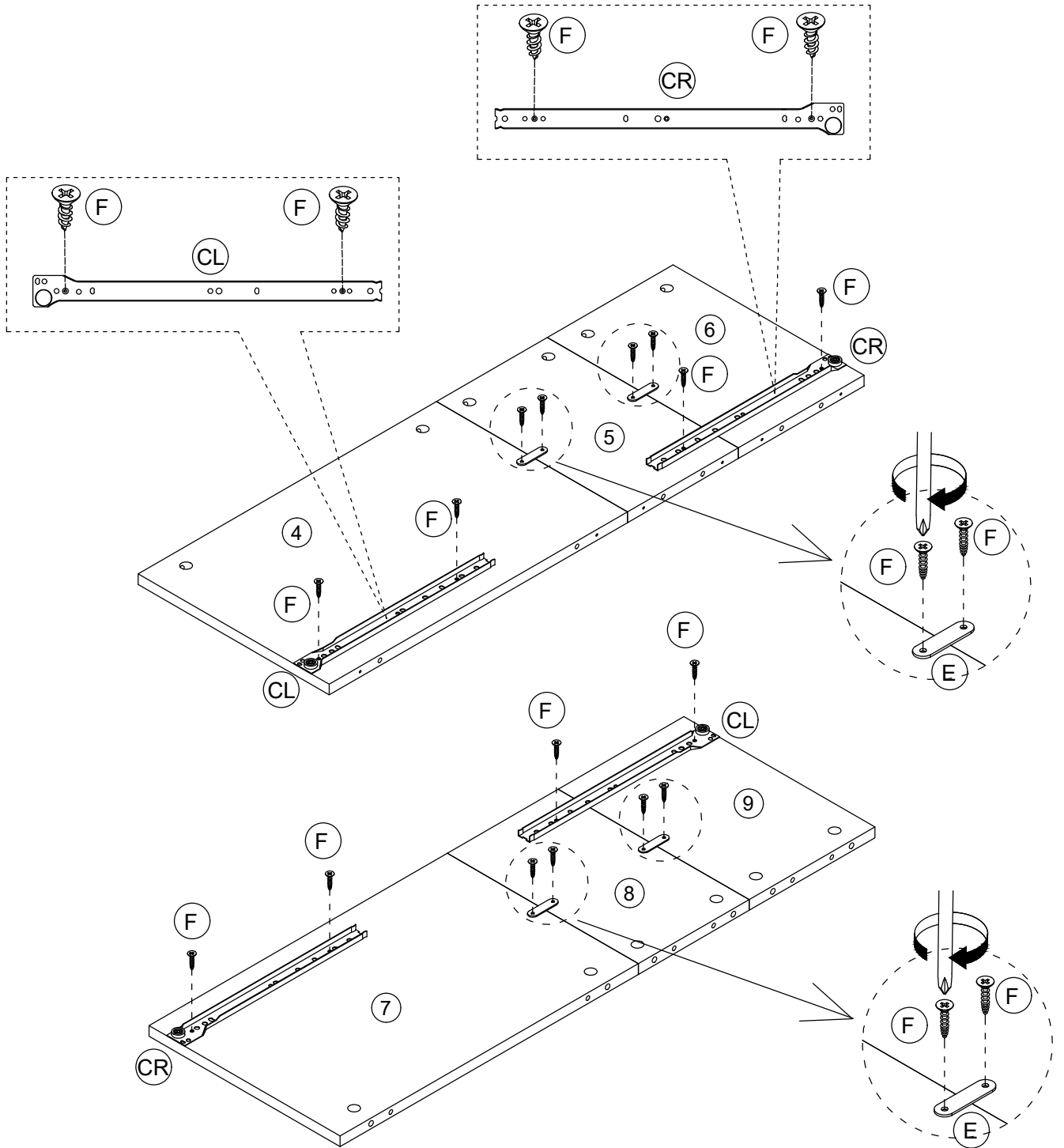

(F)



3.5*12mm Screw x 16

(CL)



300mm runner x 2

(CR)



300mm runner x 2

(E)

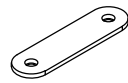

Iron sheet x 4

Assembly Instructions

Step 3

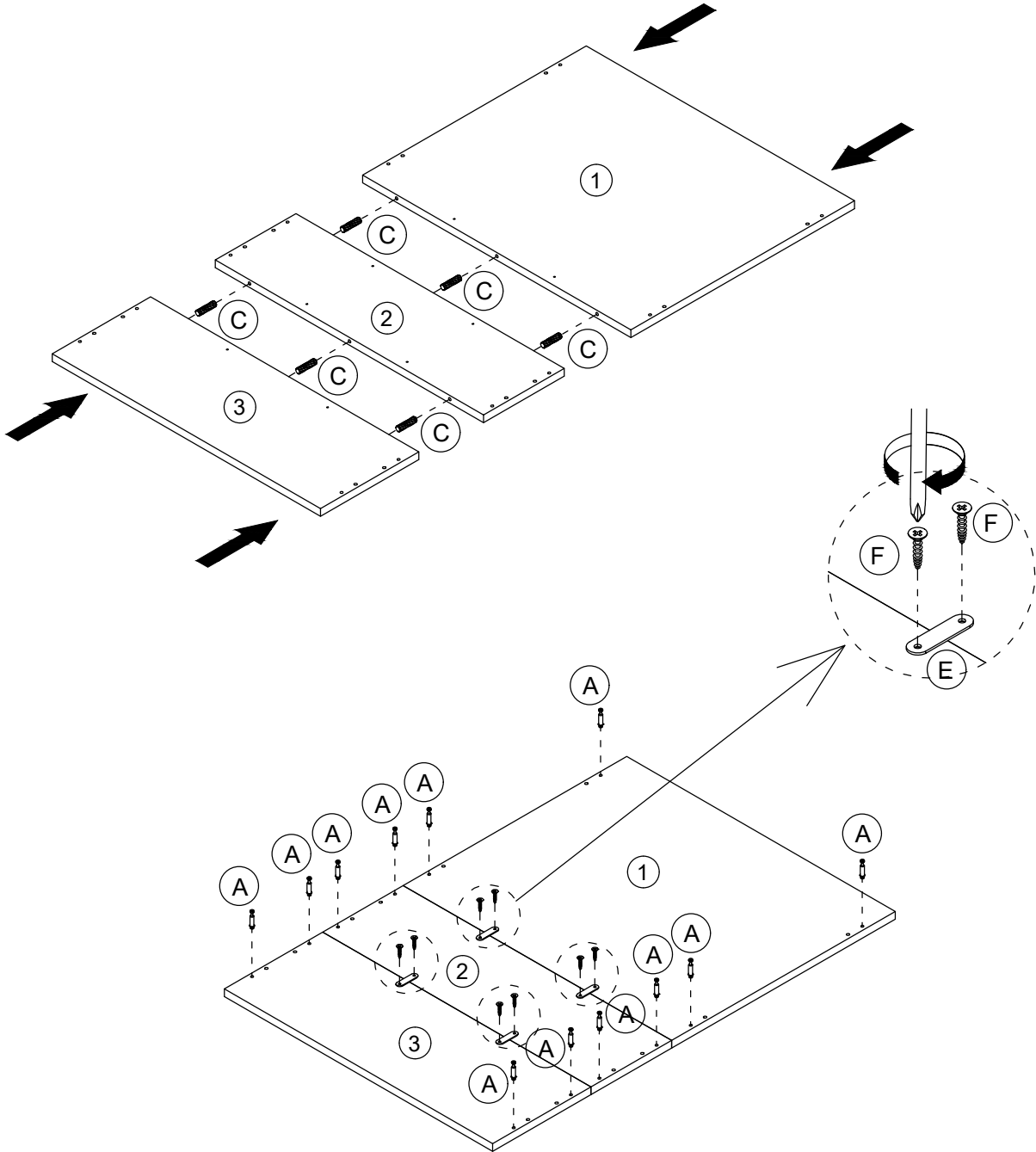

(A)

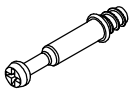

Cam Bolt x 12

(C)



Dowel x 6

(F)



3.5*12mm Screw x 8

(E)

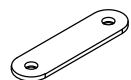

Iron sheet x 4

Assembly Instructions

Step 4

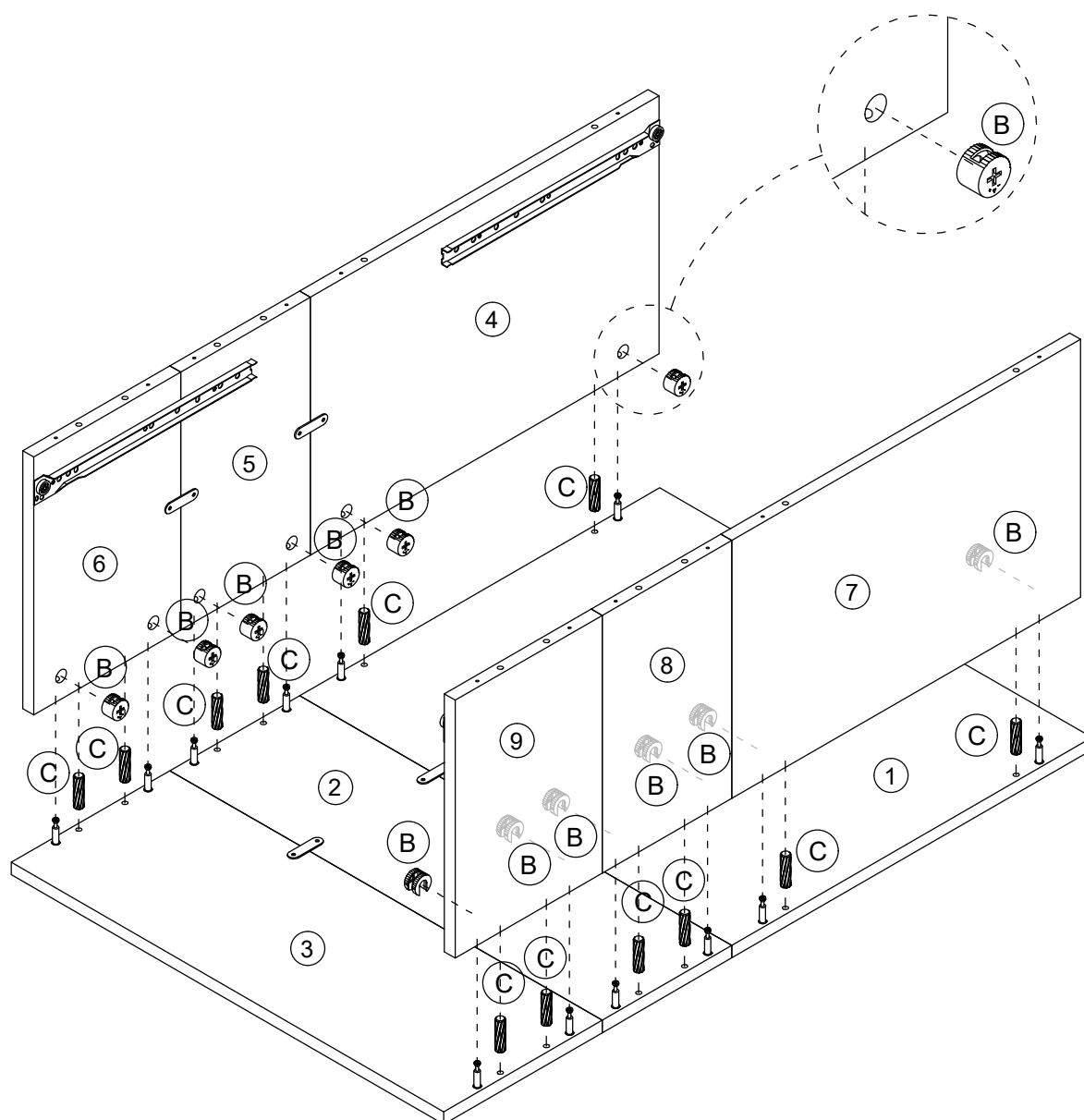

B



Cam lock x 12

C



Dowel x 12

Assembly Instructions

Step 5

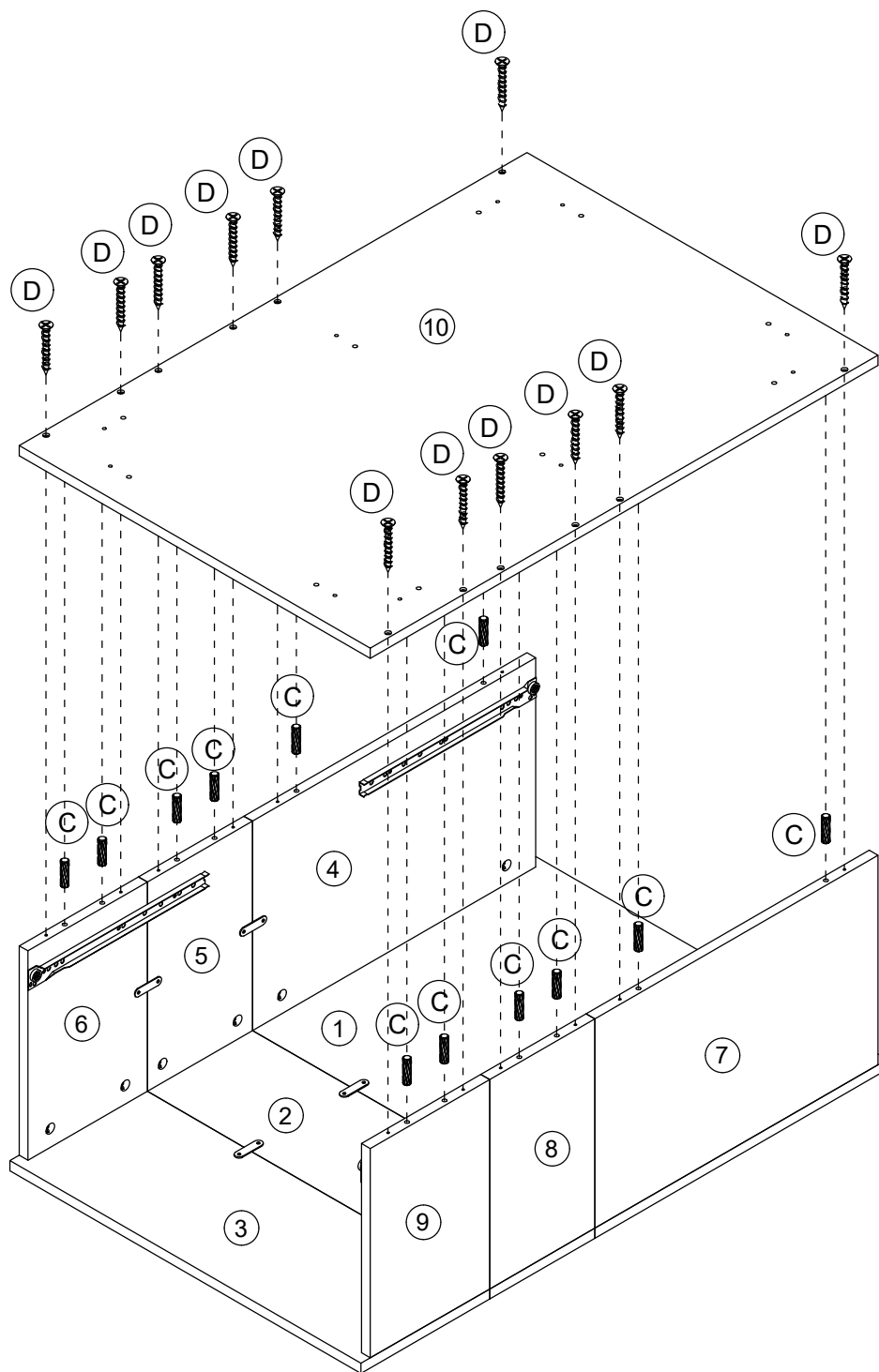

D



4*35mm Screw x 12

C



Dowel x 12

Assembly Instructions

Step 6

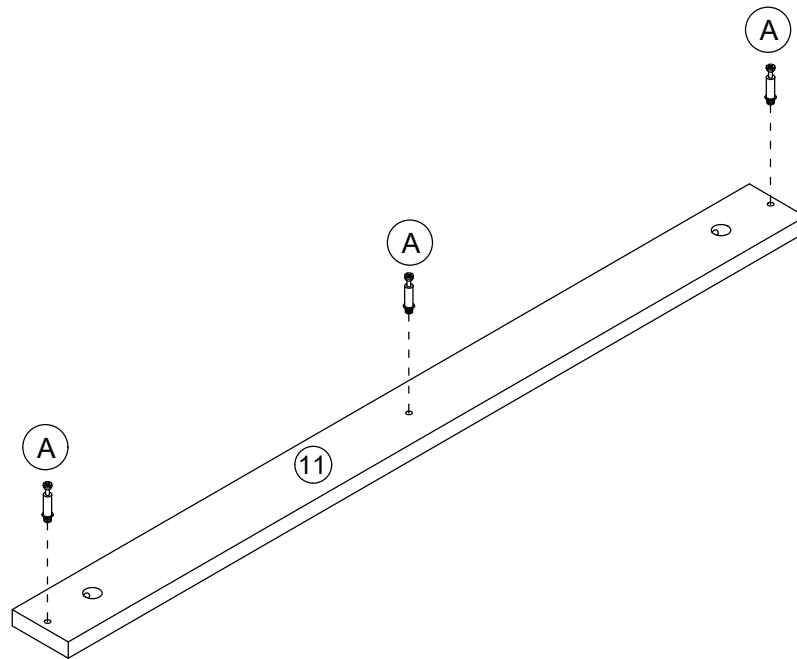

x2

A

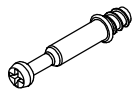

Cam Bolt x 6

Step 7

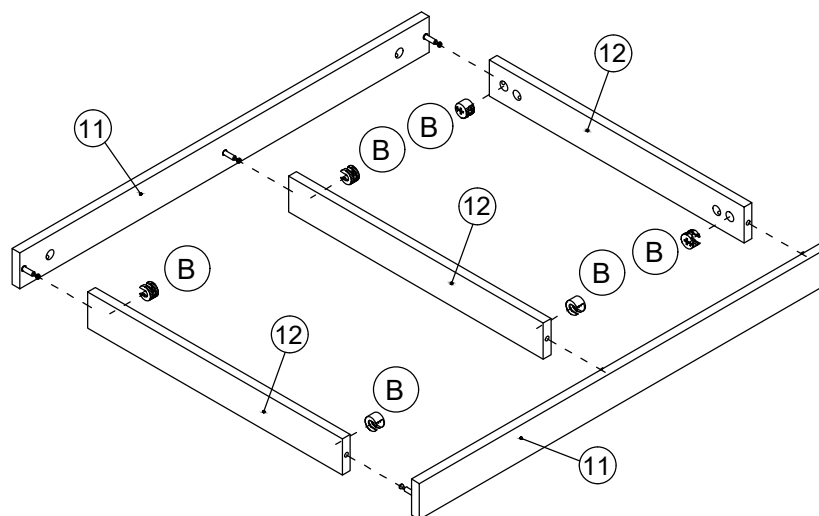

B



Cam lock x 6

Assembly Instructions

Step 8

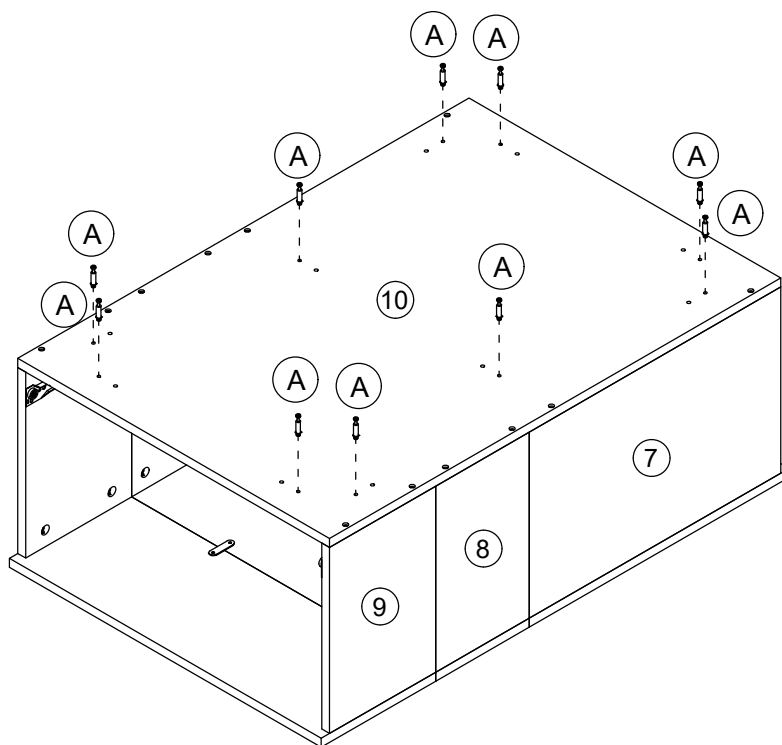

A

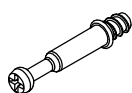

Cam Bolt x 10

Step 9

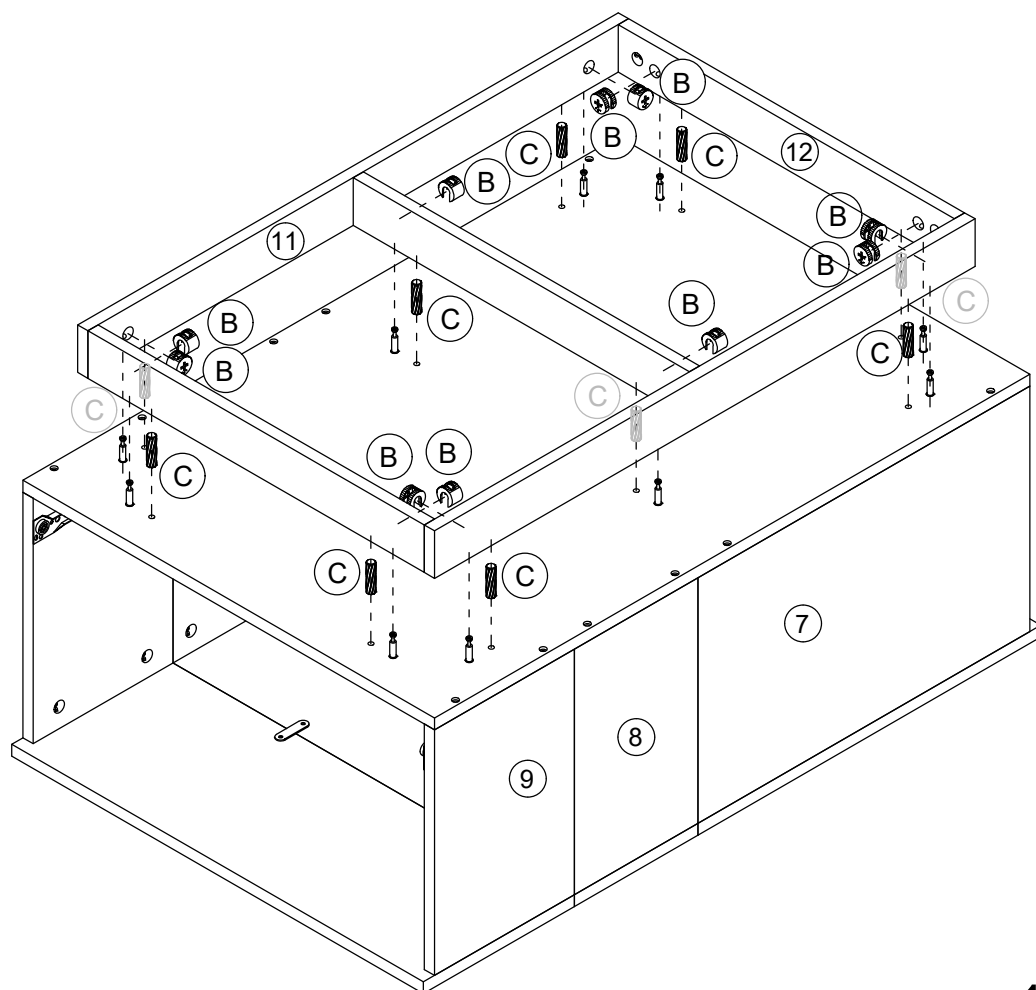

B



Cam lock x 10

C



Dowel x 10

Assembly Instructions

Step 10

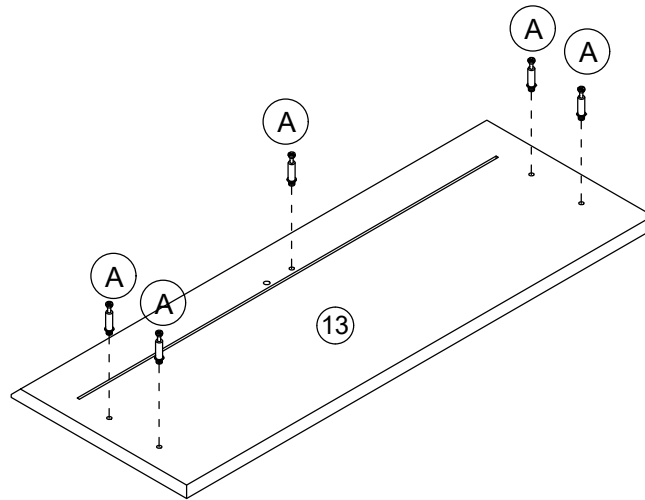

x2

A

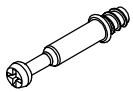

Cam Bolt x 10

Step 11

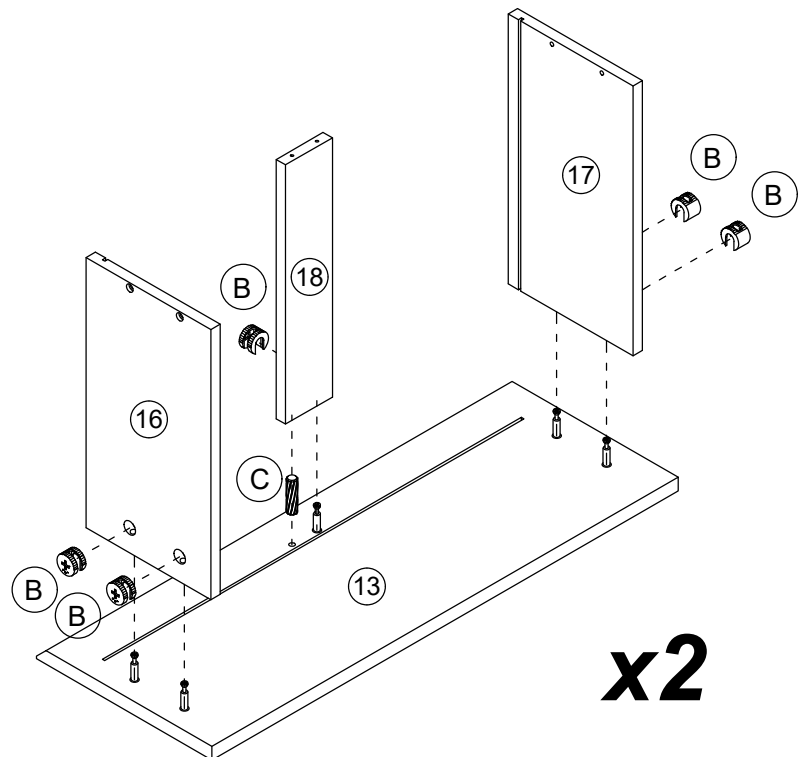

x2

B



Cam lock x 10

C



Dowel x 2

Assembly Instructions

Step 12

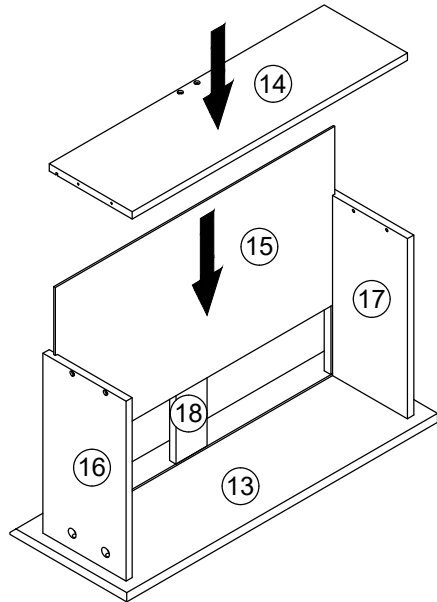

x2

Step 13

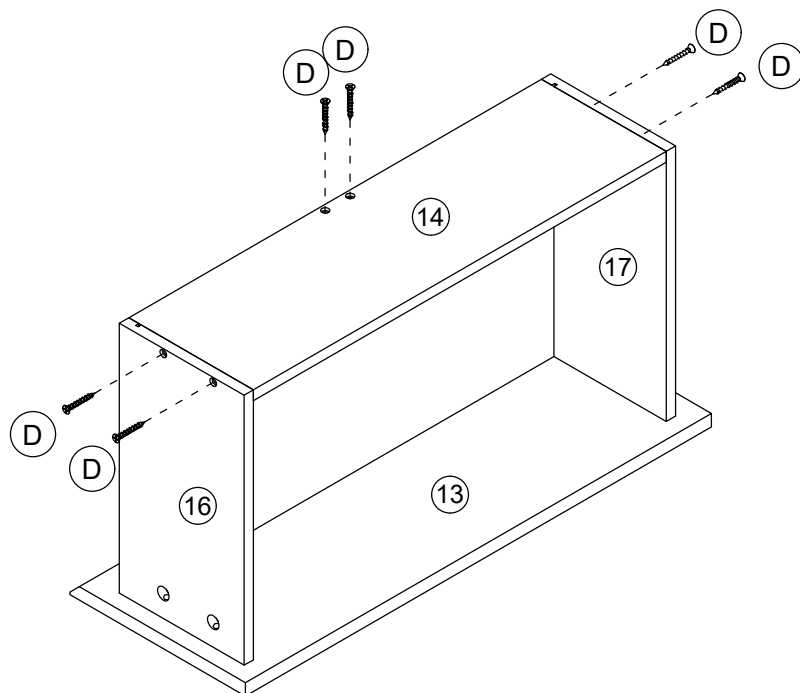

x2

(D)





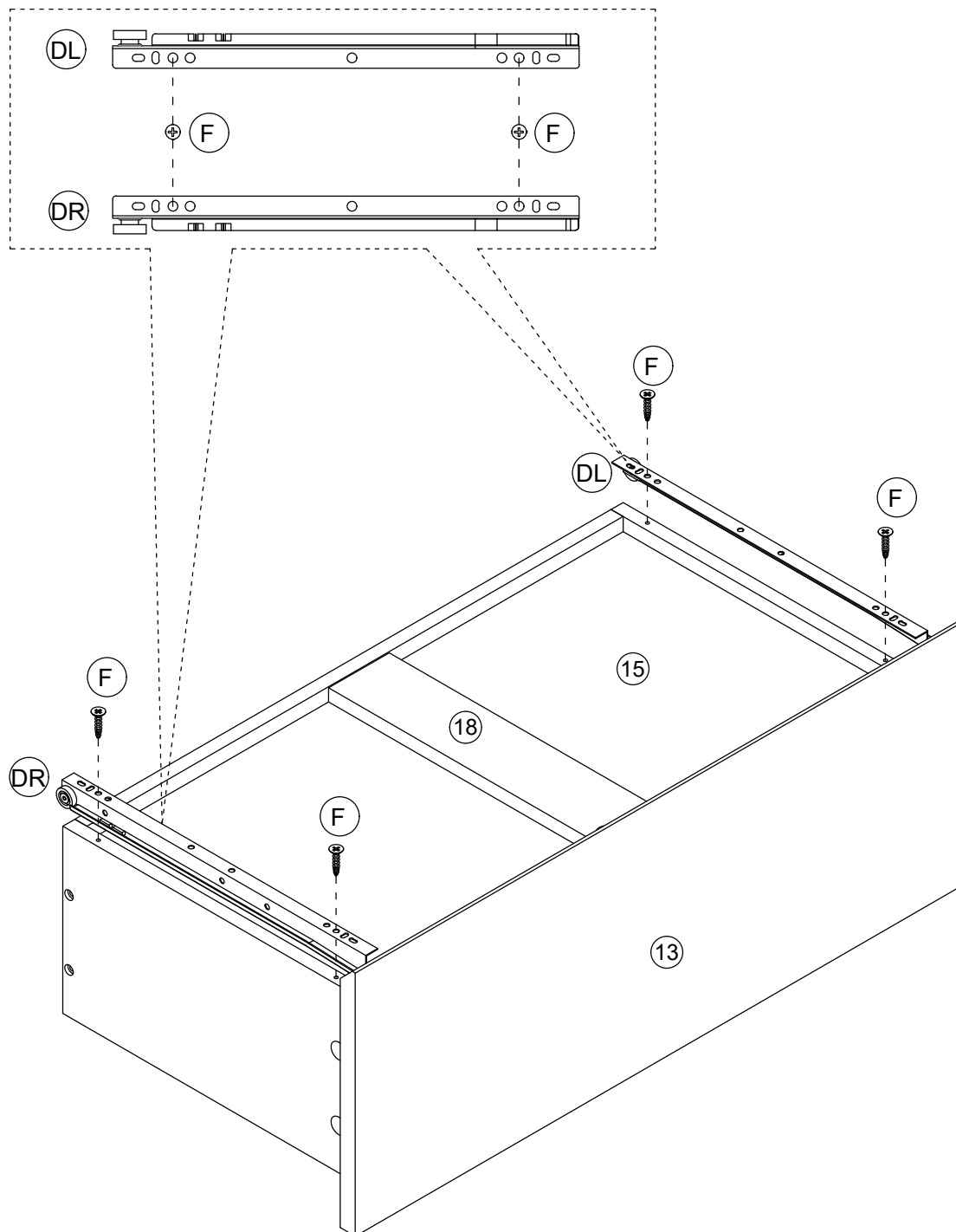

4*35mm Screw x 12

Assembly Instructions

Step 14

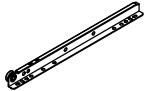

x2

 	 	 
3.5*12mm Screw x 8	300mm runner x 2	300mm runner x 2

Assembly Instructions

Step 15

