

14FT Trampoline with SWING

Assembly instruction, installation, use, maintenance and care

USER MANUAL

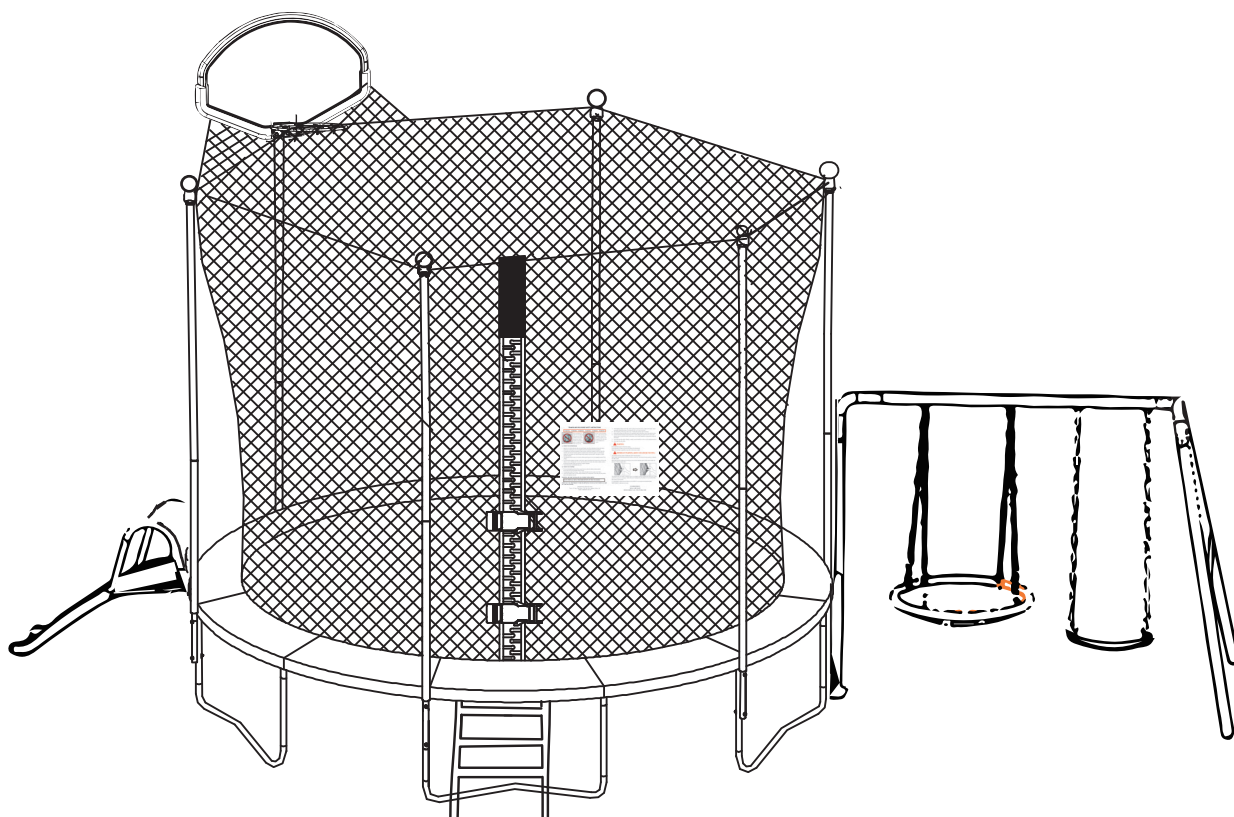

Caution

- Don't try to somersaults or cartwheels. Falling on the head or neck can result in paralysis or even death.
- No more than one person at the same time making use of the trampoline. Multiple users can increase the risk of injury.
- Use the trampoline only under the supervision of an adult with knowledge of use. These instructions are for your safety. Please carefully read each of them before assembly and use of the trampoline. We retain this manual for future reference.
- The maximum user weight should not exceed 260lbs / 120Kg for this product.

Caution



No flips or twists, a fall on the head or Neck can result in paralysis or even death.



Not more than one person at the same time on the trampoline (260 lbs / 120 kg).



Do not use in case of plaster or any injury to the leg, ARM, Head, neck or back.



Do not allow the use of the trampoline for children under six (6) years of age.













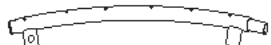
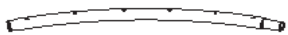

Remove all sharp or Hard objects such as Jewelry, eyeglasses and / or sunglasses before jumping.



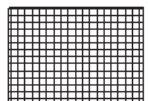

In case of pregnancy, do not use it without your doctor's consent.

Inspection before use, check that the legs are fixed, without Springs Loose, mesh, mat and security are in place and in good condition without scratches.





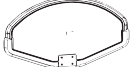

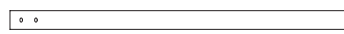
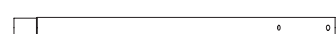
Part List - Trampoline





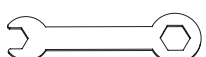







Number	Diagram	Description	Quantity
1		Trampoline Mat	1
2		Frame Pad	1
3		Top Rails with Legs	6
4		Top Rail	6
5		Base Leg	6
6A		Vertical extension leg	6
6B		Vertical extension leg (Two Holes)	6
7		Galvanized Springs 28N (5 1/2 "long)	72
9		Loading Spring Tool	1
10		Top Frame Tube(with foam)	5
11		Bottom Frame Tube(with foam)	5
12		Mesh Cover	1
K1		Strap Circle	5

Basketball Hoop

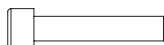
Number	Diagram	Description	Quantity
13		Board	1
14		Ring	1
10A		Upper Board Tube (No Foam)	1
11A		Lower Board Tube (No Foam)	1

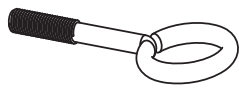
Part list - Tools

Number	Diagram	Description	Quantity
A		Screw	13
B		Small Spring Washer	11
C		Allen Tool	1
E		Tool	1
F		Gap Spacer	5
F1		Gap Spacer	7
G		Bolt	5
P		Washer	2

G1		Bolt	2
H		Big Spring Wahser	7
I		Lock Nut	9
J		Arc Washer	7
L		Rope	8
K1		Strap Circle	5
N		Round Head bolt	2
O		Washer	2
X		Ladder	1
D		Nine word hook	5
H1		Big Spring Wahser	5
I1		Lock Nut	5
J1		Arc Washer	5

Assemble Frame of Trampoline

Before you start: check all the steps before assembling and Read All precautions before using the trampoline. It requires at least two adults to assemble the trampoline. Must use Protective Gloves to avoid injury during the Assembly

Step 1 - Assemble Frame

Locate the following 30 pieces of Steel Tubes that will need to begin to assemble the trampoline:

- 6 - Top rail with Legs (# 3)
- 6 - Top Rails (# 4)
- 6 - Base Leg (# 5)
- 6 - Vertical extension leg(# 6A)
- 6 - Vertical extension leg with two (2) Holes (# 6B)

Note: all parts are interchangeable with the same number and orientation have no right or left.

Make sure you have a spacious, clean and dry place, suitable for the assembly of the trampoline. It is essential that the right place for this trampoline is completely flat and level. If the ground is uneven, this could cause movement in the frame and can cause stress in the united sections of the trampoline and / or can cause serious injury.

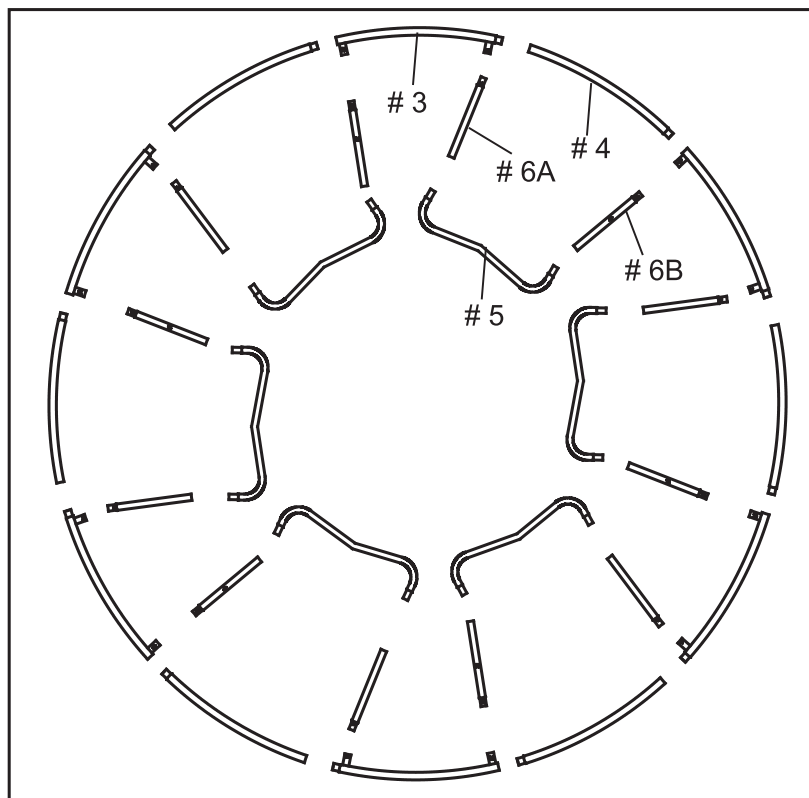

FIGURE 1

Step 2 - Leg Support Assembly

Connect the vertical extensions leg (# 6A and #6B) to the base leg (# 5) as shown in Figure 2 (The mounted parts will be referred to hereafter as "Support Leg"). Repeat this step for all the support legs.

Note: The vertical extension leg (#6B) has two holes (2)

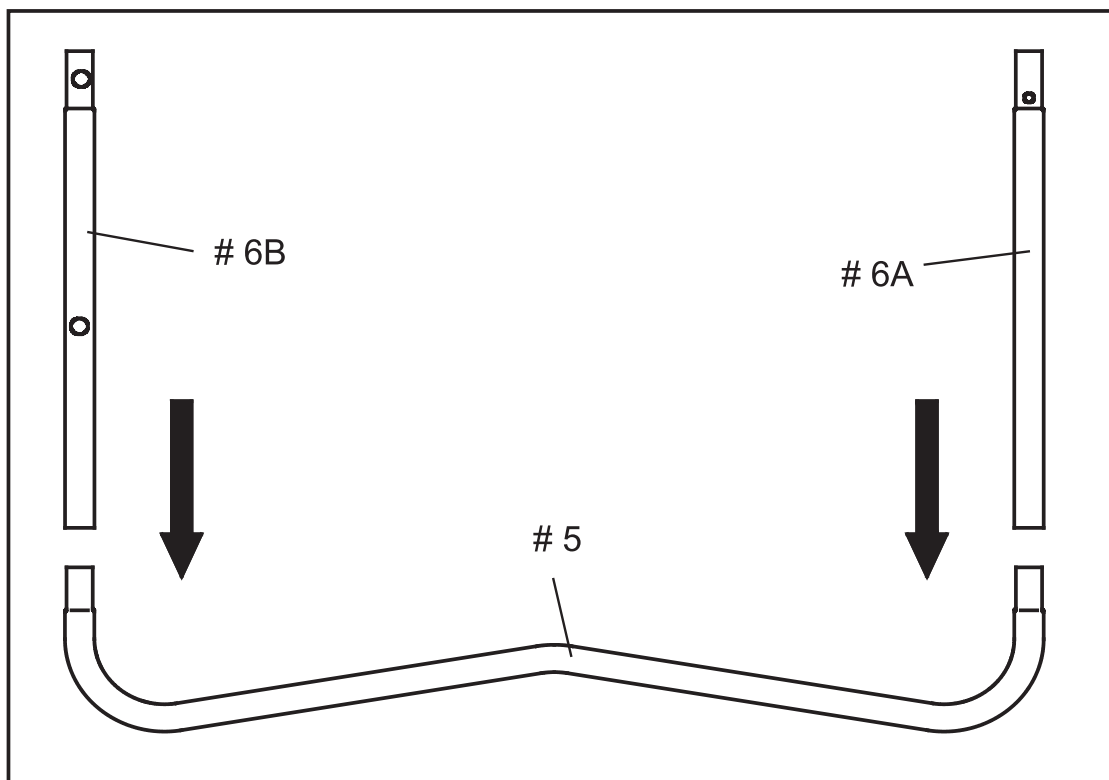

FIGURE 2

Step 3 - Main rail Assembly with screw

At this point, two people are needed to assemble the trampoline.

Lift two sets of legs brackets mounted in STEP 2 to a vertical position (standing). Connect one end of the top rail (# 3) to the vertical extension of the leg (# 6A) and the other other end to the vertica leg extension with two holes (# 6B) as shown in Figure 3 .

Repeat the same way for all the top Rails with Legs

Tip: Make sure that the holes in all parts of the steel pipe are aligned out: This is important for the following installation of the net.

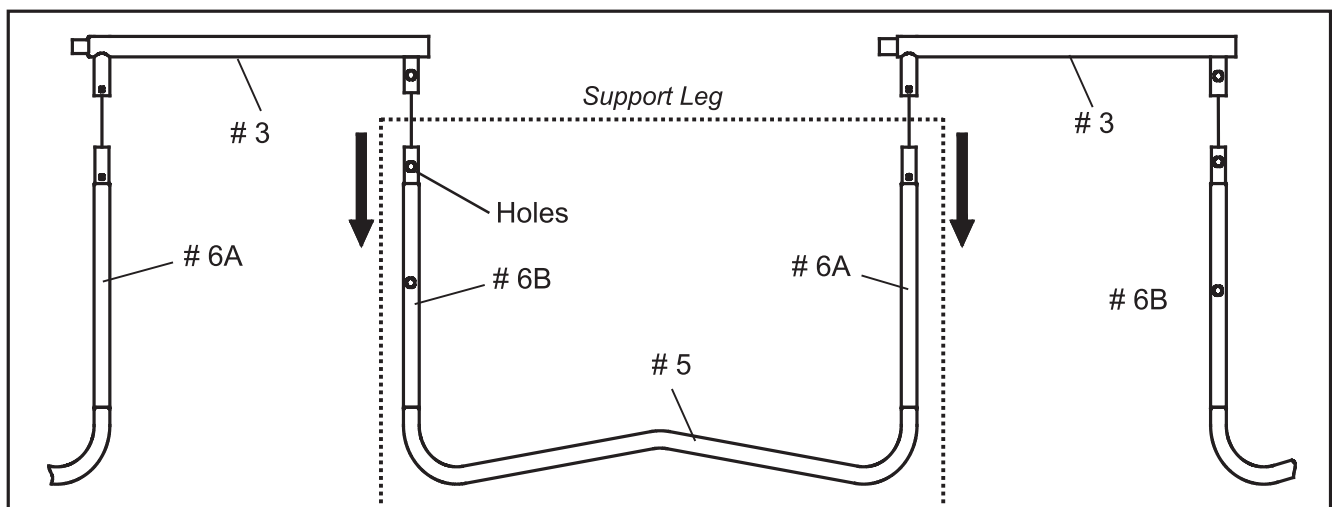
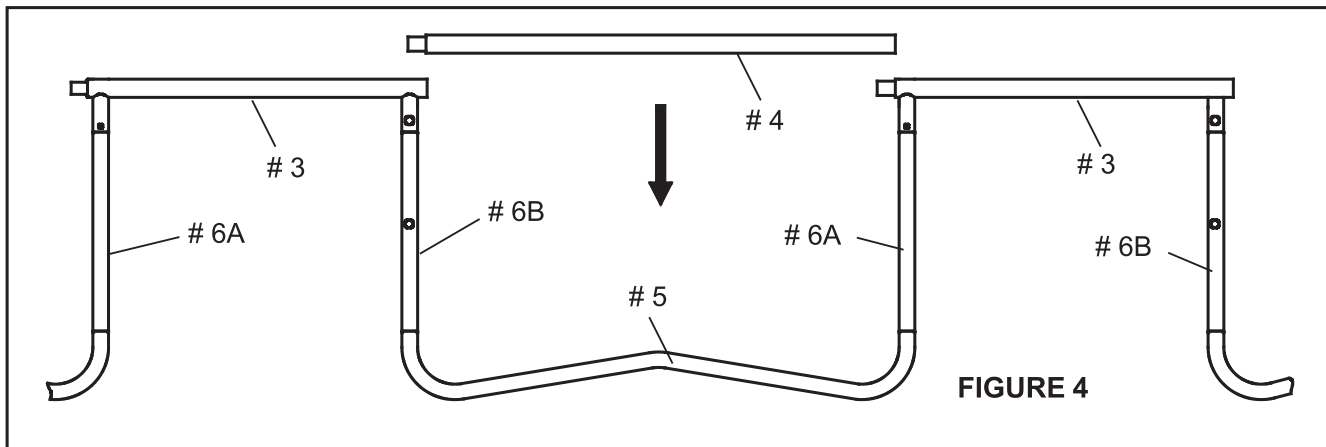

FIGURE 3

Step 4 - Top Rail Assembly

Complete the main frame by inserting top rail (# 4) on top rail (# 3) as shown in Figure 4.



Step 5 - Securing the support leg to the top rail.

Secure one side of the support leg - Extension of vertical leg (# 6A) to the frame using the locking screw (#A), washer small security (# B) and Allen key (# C) as shown in FIGURE 5. If the holes do not match, turn the extension of the Vertical leg back and forth to align the holes. Repeat the same way for all the leg holders.

NOTE:

The holes on the other side of the support leg will be used later, when installing the cover net - after all the springs (# 7) have been installed (steps 7 - 10).

Do not overtighten the screws in this moment, screws should be tightened until the end

Tip: make sure that the holes in all the pieces of Steel Pipe Line and the hole is outwards. This is important for the installation of the cover later.

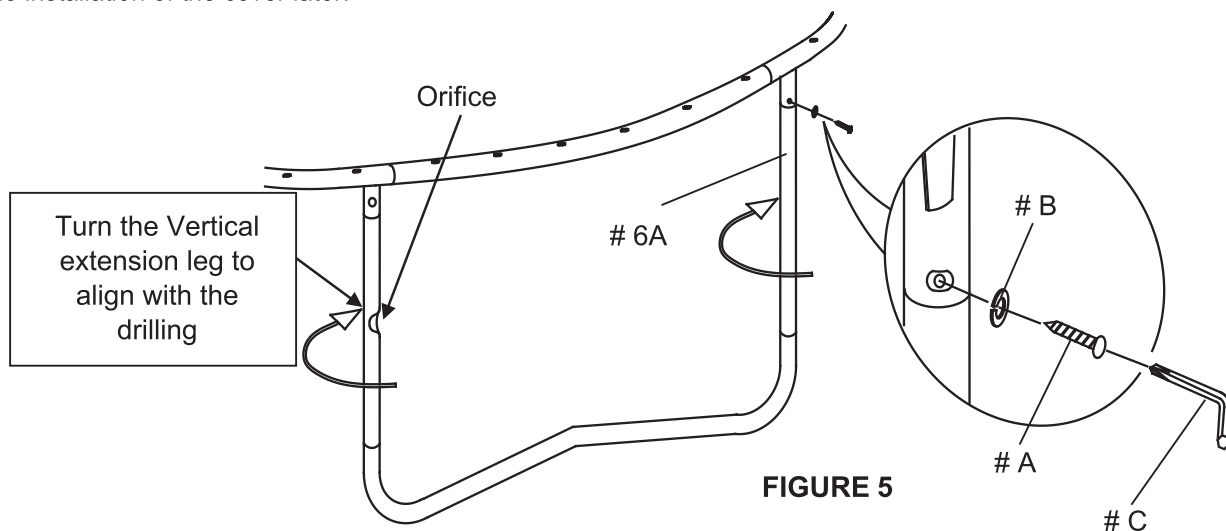

Assembly of the trampoline Mat

To assemble the trampoline Mat, only need the Spring Loading Tool (# 9) included in this product.

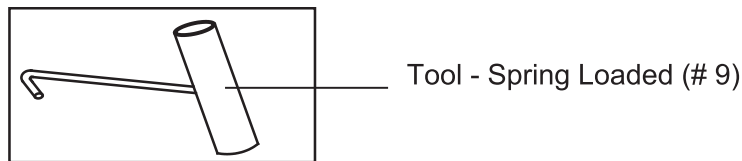

Step 6 - place the Mat

Place the trampoline Mat (#1) on the floor in the Interior of the frame assembled with the Label facing up as shown in Figure 6. Align the warning labels with any of the trampoline legs, make sure that the warning labels are up. This makes the installation process easier.

Select a starting point in the frame and name it "zero" point (pick a point that is above a frame leg and facing a warning label).

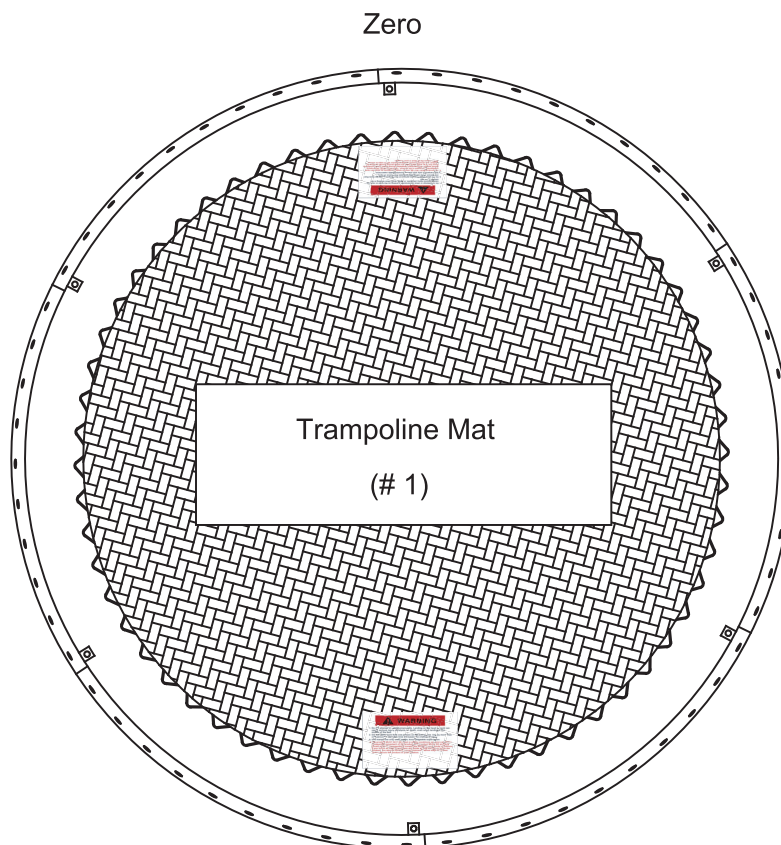

FIGURE 6

STEP 7 - Assemble Springs

By placing the Springs, do not put hands, Arms, Legs or other body part near the connection Points (i.e., joints Connecting Steel Pipe connection points) can become pinched points when the Springs are contracted. Use Heavy Duty work gloves protect your hands from pinching by Springs and Protective Glasses to prevent Eye injury. Make sure that no children playing nearby when joining in springs.

Starting at the "Zero Point", Connect one end of the Spring (# 7) with the spring load tool (# 9) in the triangular ring and pull the other end securing it in the hole of the main frame, as shown in Figure 7.

Tap the end of the spring (# 7) with the handle of the spring load tool to ensure that the springs are securely locked into the hole.

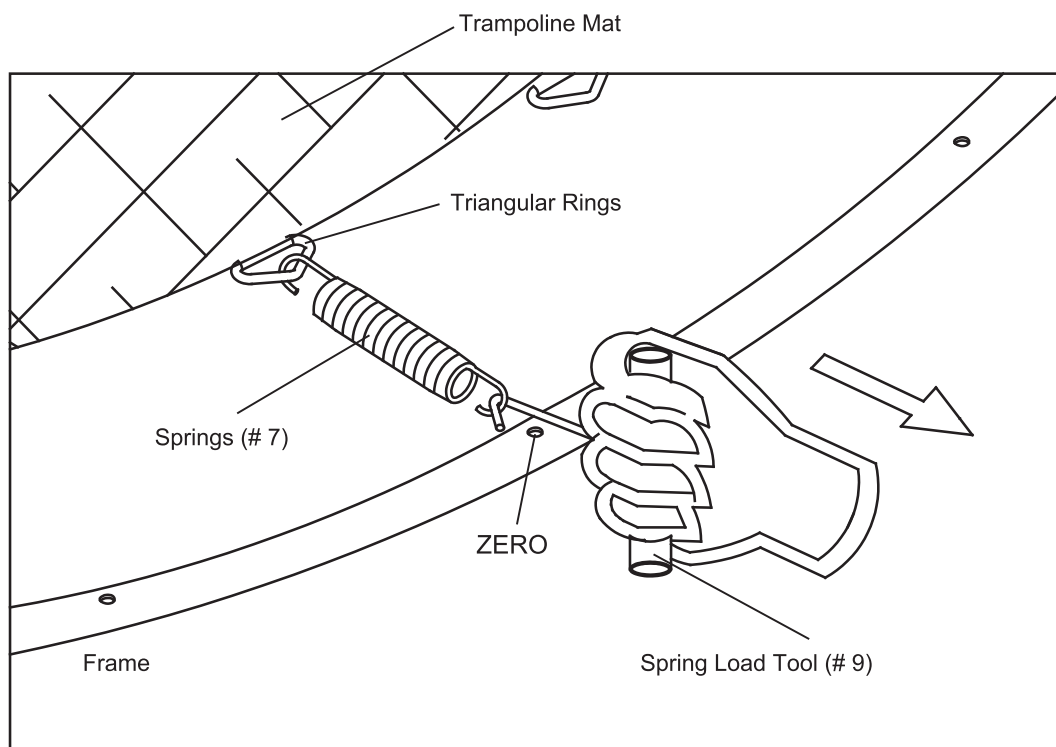

FIGURE 7

Step 8 - Assemble Springs

After having secured the spring in the "Zero Point", Count to 36 holes on the opposite side of the frame and put a Spring in the same way as in the previous step. For a uniform distribution of the spring tension and ease of installation, the springs must always be installed at opposite sides of the main frame of an Alternating Way, i.e., Zero after 36, followed by 18 and 54 as shown in Figure 8.

Tip: the number of triangular Rings sewn in the table is equal to the number of holes in the main frame. Note that if you miscounted a triangular hole or ring, remove and reinstall the Springs in the necessary Place, maintaining a uniform distribution of tension as detailed above.

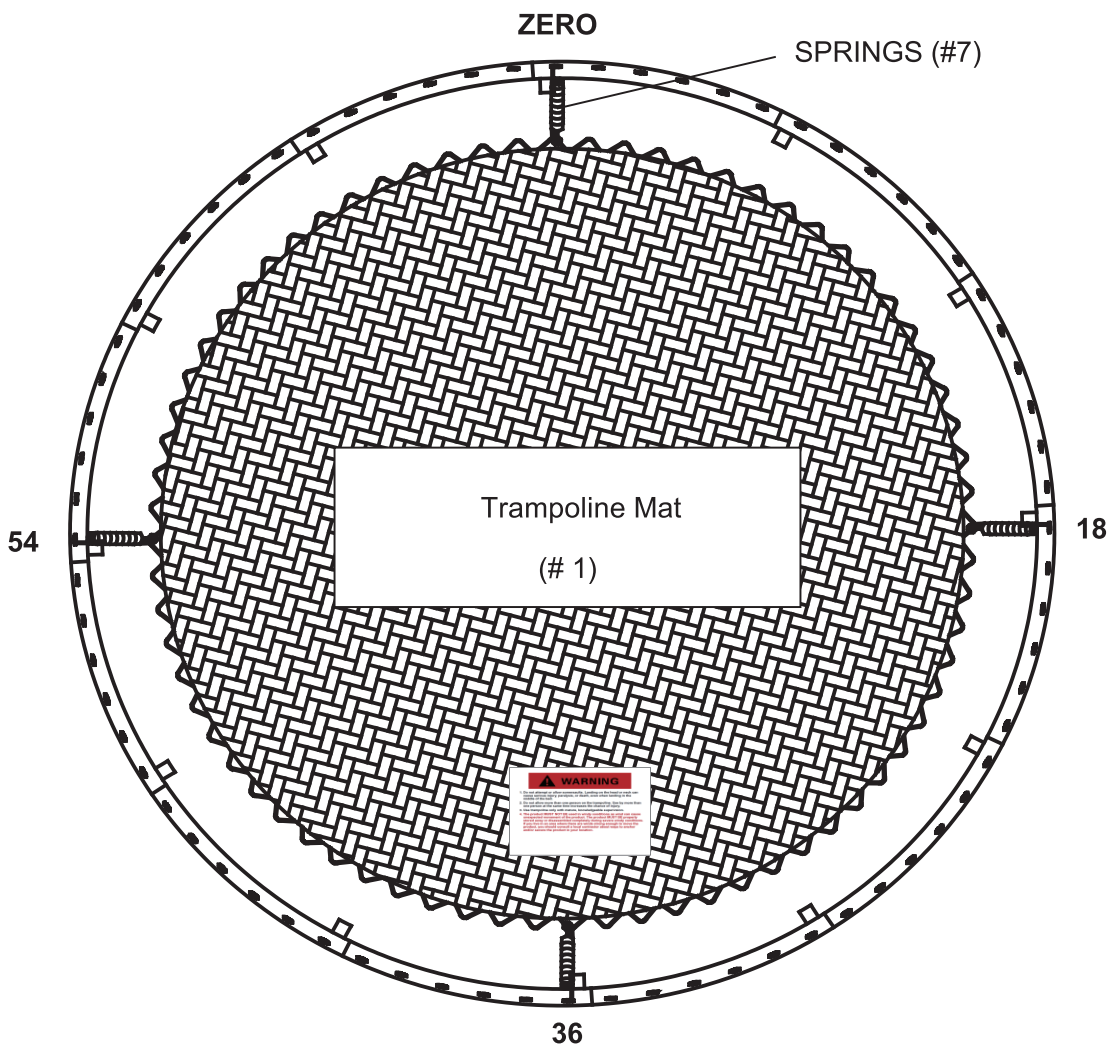
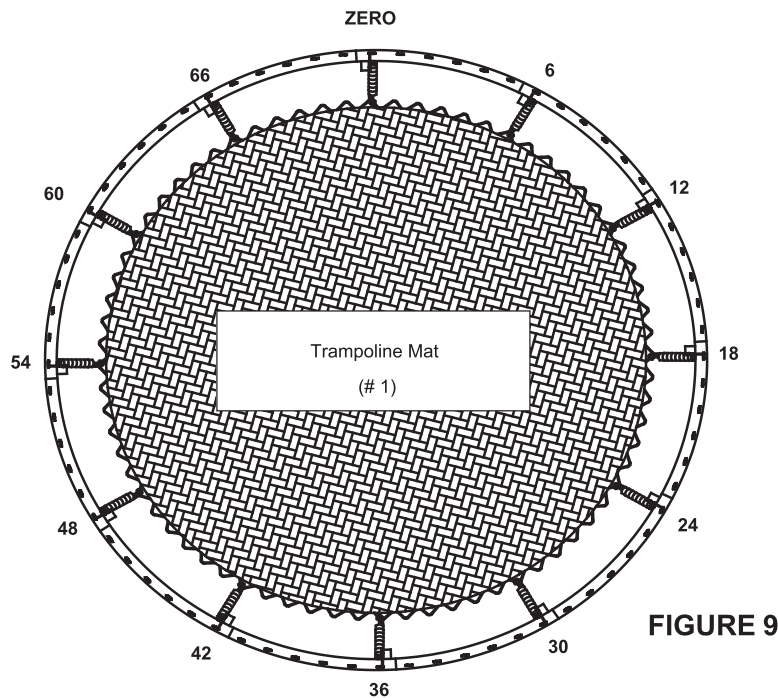

FIGURE 8

Step 9 - Assemble Springs

Place a spring each interval of the sixth hole. For a uniform distribution of tension and ease of assembly, the springs should be placed on opposite sides of the main frame. Alternatively, IE 6 after 24 and 42, 60, etc. besides the Springs above should now have Springs at 6, 12, 24, 30, 42, 48, 60 and 66, as shown in Figure 9.



Step 10

Continue placing the remaining 60 springs in the same manner as in the previous step. The springs shall be placed on opposite sides of each one to make sure that the trampoline Mat is taut perfectly.

IMPORTANT: you must make sure the springs are perfectly placed and return to step 5 and tighten the screws of the support legs

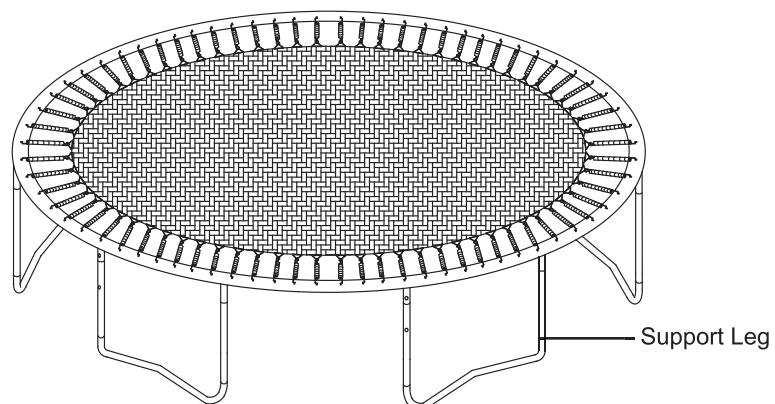
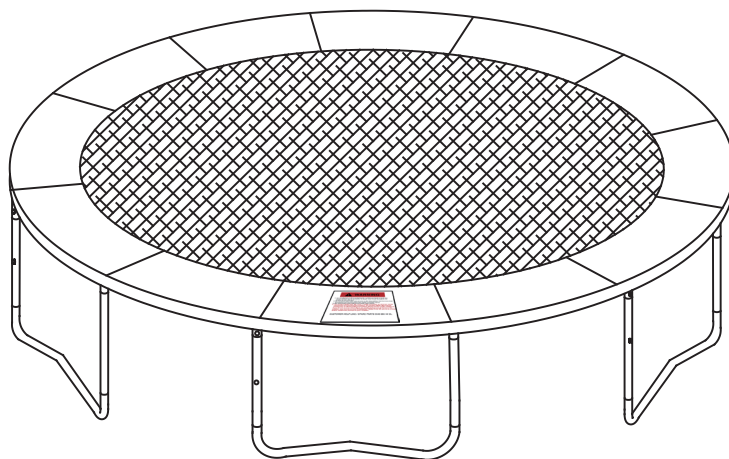

FIGURE 10

Assemble Frame Pad

Never use the trampoline without the frame pad, the pad frame reduces the risk of injury by striking the metal structure. Inspect the cushion frame and metal parts are completely covered by the frame pad before each use.

Note: Please ensure that the warning label is placed between the support leg main frame, as shown below: This is to ensure that the label is in front of the entrance trampoline



Step 11

Place the Frame Pad (#2) on the trampoline and fully cover the springs and steel frame. Align the straps to leg sockets and wrap the elastic straps to the connectors of the legs. First, tie a knot and then tie in a bow on one side, as shown in Figure 11. Repeat this step for all the outer bands.

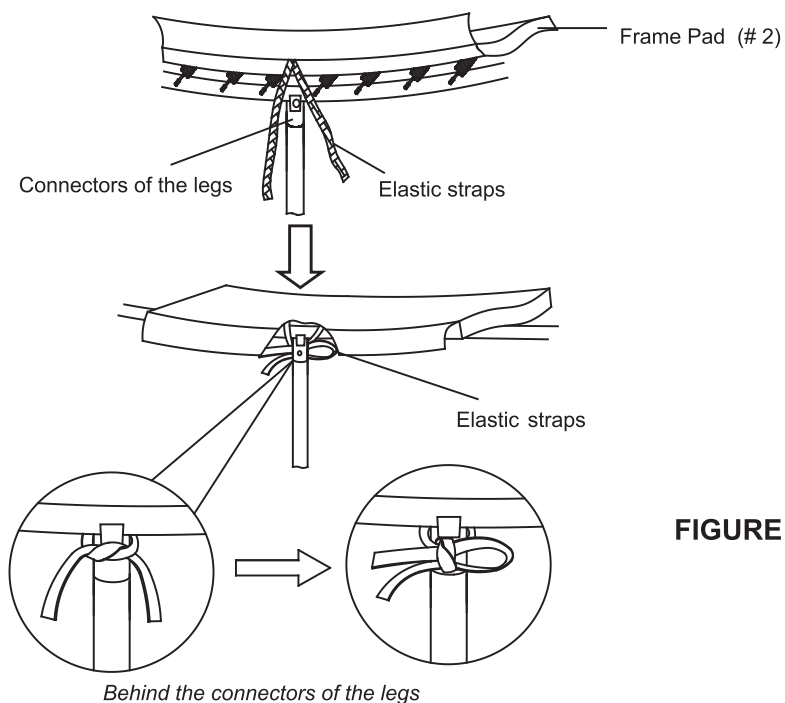

FIGURE 11

Step 12

Finally, wrap the internal elastic straps around triangular ring and tie a knot as shown in the diagram, then tie in a bow on one side as shown in Figure 12. Repeat this step for all inner bands.

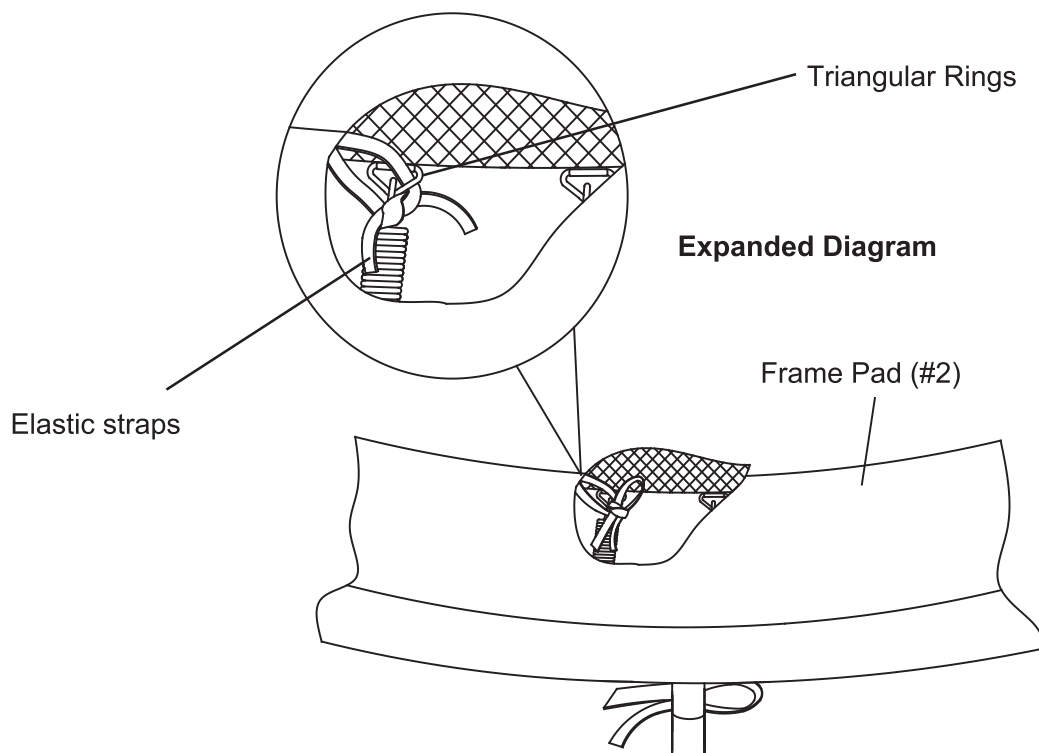

FIGURE 12

Make sure the knots and ties are tight for all elastic straps

Make sure the pad frame is securely installed in the frame and completely covers the frame and all springs before using the trampoline. Do not use the trampoline if a triangular ring fails or is damaged.

Conduct a full Inspection of the trampoline to ensure that all parties are properly assembled.

Read This Manual and make sure you fully understand all warnings in the various Warning signals.

Disassembly of Trampoline

If you have to disassemble the trampoline please follow the assembly instructions in the opposite direction and take special care to keep the parts. Keep the original packaging for transport.

Assembly of the Trampoline Mesh Cover

Before you start:

This trampoline should only be used when the network is assembled correctly. The net of the trampoline must be revised thoroughly before each use to ensure that there are no breakages or damage. PLEASE READ CAREFULLY ALL the important safety instructions in this manual and all warnings on the product before use

Step 13

Place bottom frame tube (with foam) (# 11) next to the support leg(i.e., the side with the 2 Holes) and secure it with the screw bolt (#G) , gap spacer (#F), arc wahser (#J) , big spring wahser (#H) and Lock Nut(#I) as shown in Figure 13.

Repeat this step for the rest 4 bottom frame tubes(with foam)

Place lower board tube (# 11) next to the last support leg and secure it with the screw bolt (# D) , gap spacer (#F1), arc wahser (#J1), big spring wahser (#H1)and Lock Nut(#I1)

Enclosure Net Tubes Assembly Diagram

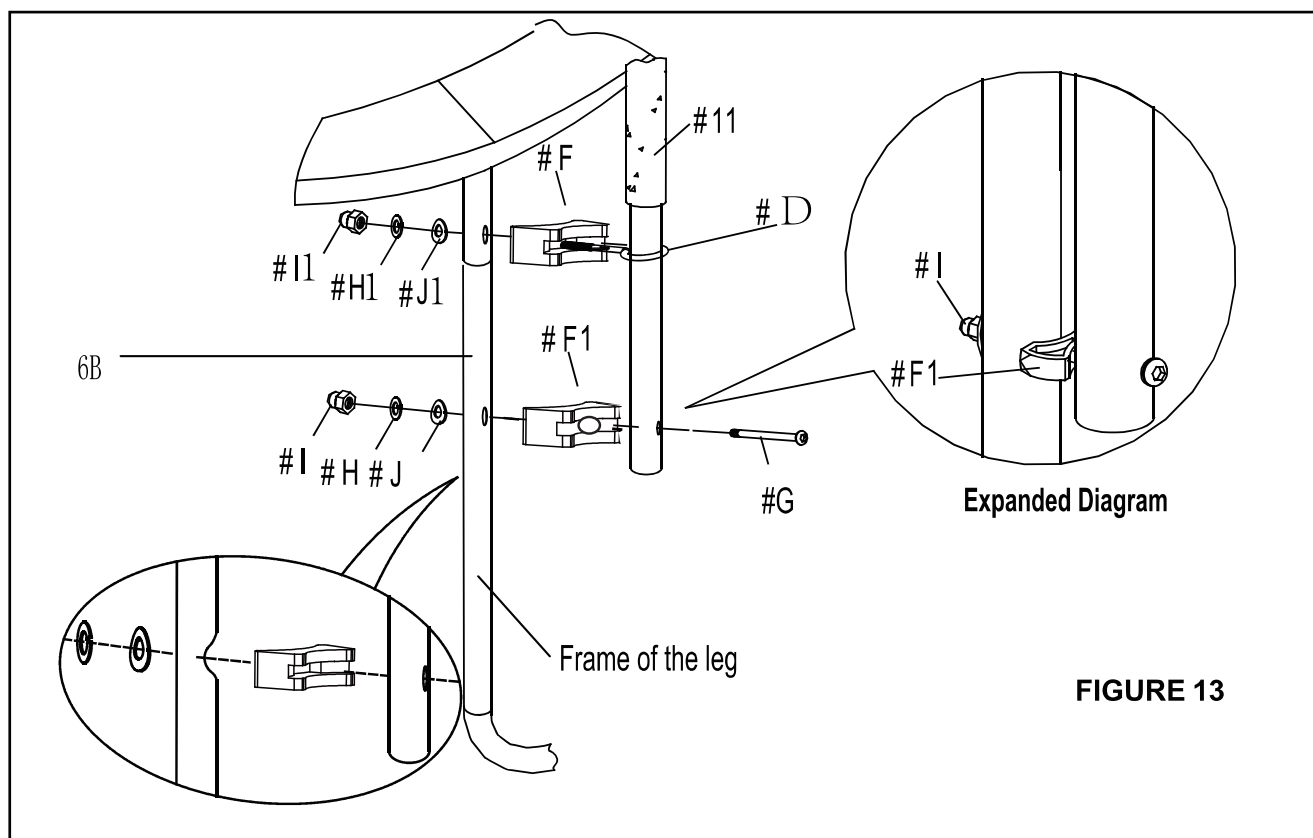

FIGURE 13

Step 14

Connect Board (# 13) and Ring(#14) with the Round Head Bolt (#N) , as shown in Figure 14. secure Round Head bolt (#N) with Wahser(#0) and Luck Nut (#I). Cover the Upper Tube(#10A). Place lower board tube (# 11A) next to the last support leg and secure it with the screw bolt (#G1) , gap spacer (#F), arc wahser (#J) , big spring wahser (#H) and Lock Nut(#I)

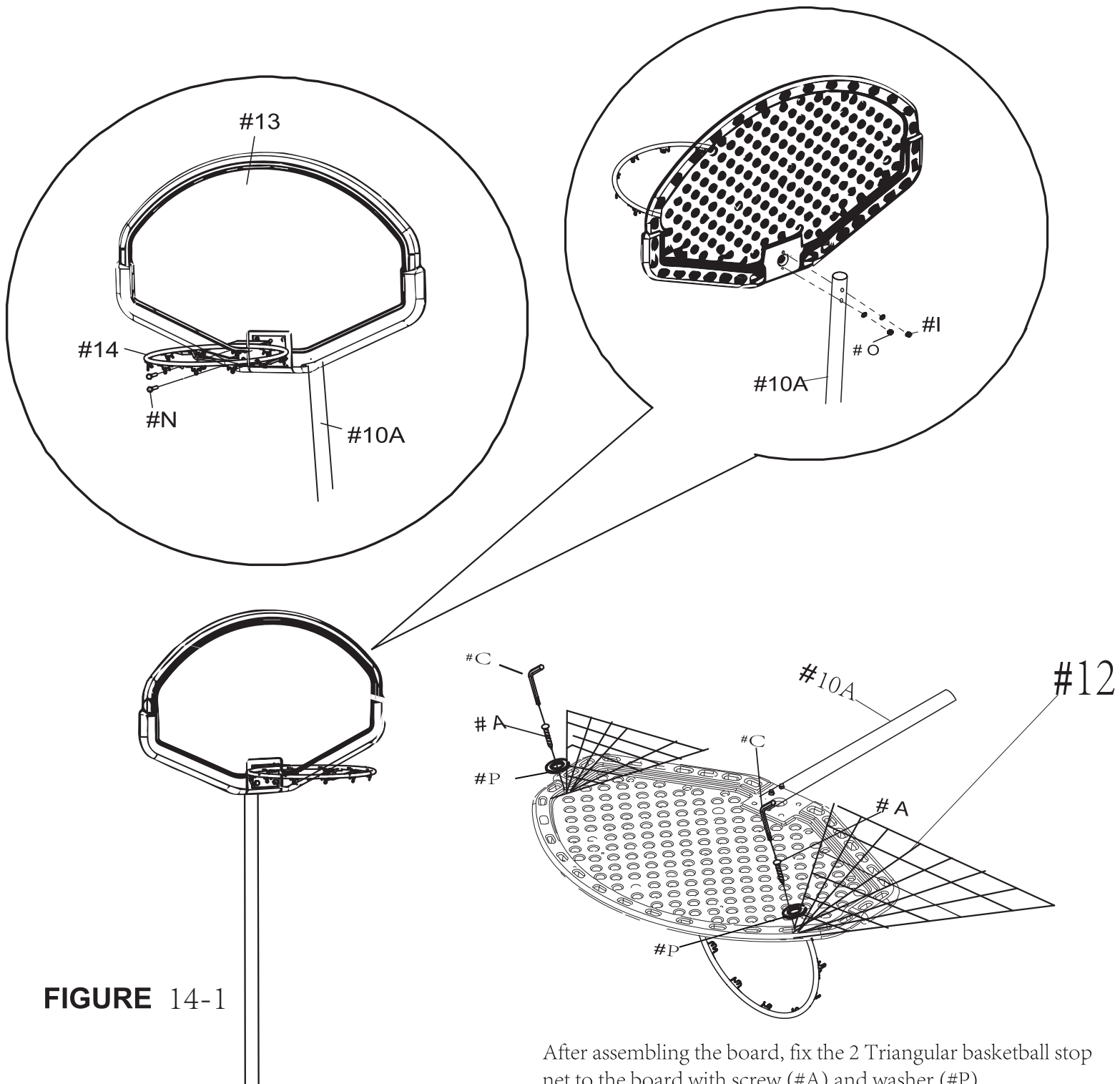

FIGURE 14-1

After assembling the board, fix the 2 Triangular basketball stop net to the board with screw (#A) and washer (#P)

Backboard Tube Assembly Diagram

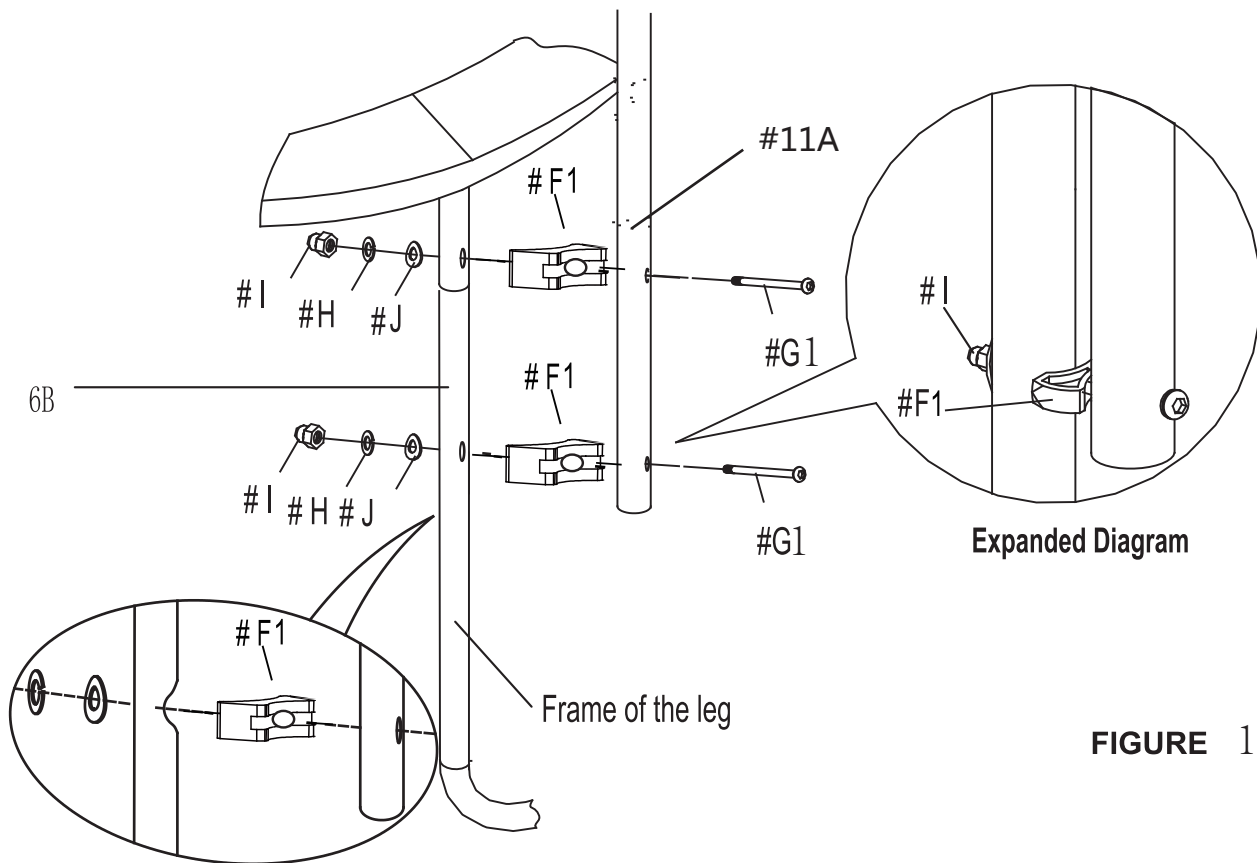

FIGURE 14-2

Step 15

Connect Upper Board Tube (#10A) and Lower Board Tube (#11A) with "U" pin, Make sure the Basketball Board faces inward the trampolene.

Connect Top Frame Tube (#10) and Bottom Frame Tube (#11) with screw (#A), Small Spring Wahser (#B) and Allen tool (#C),

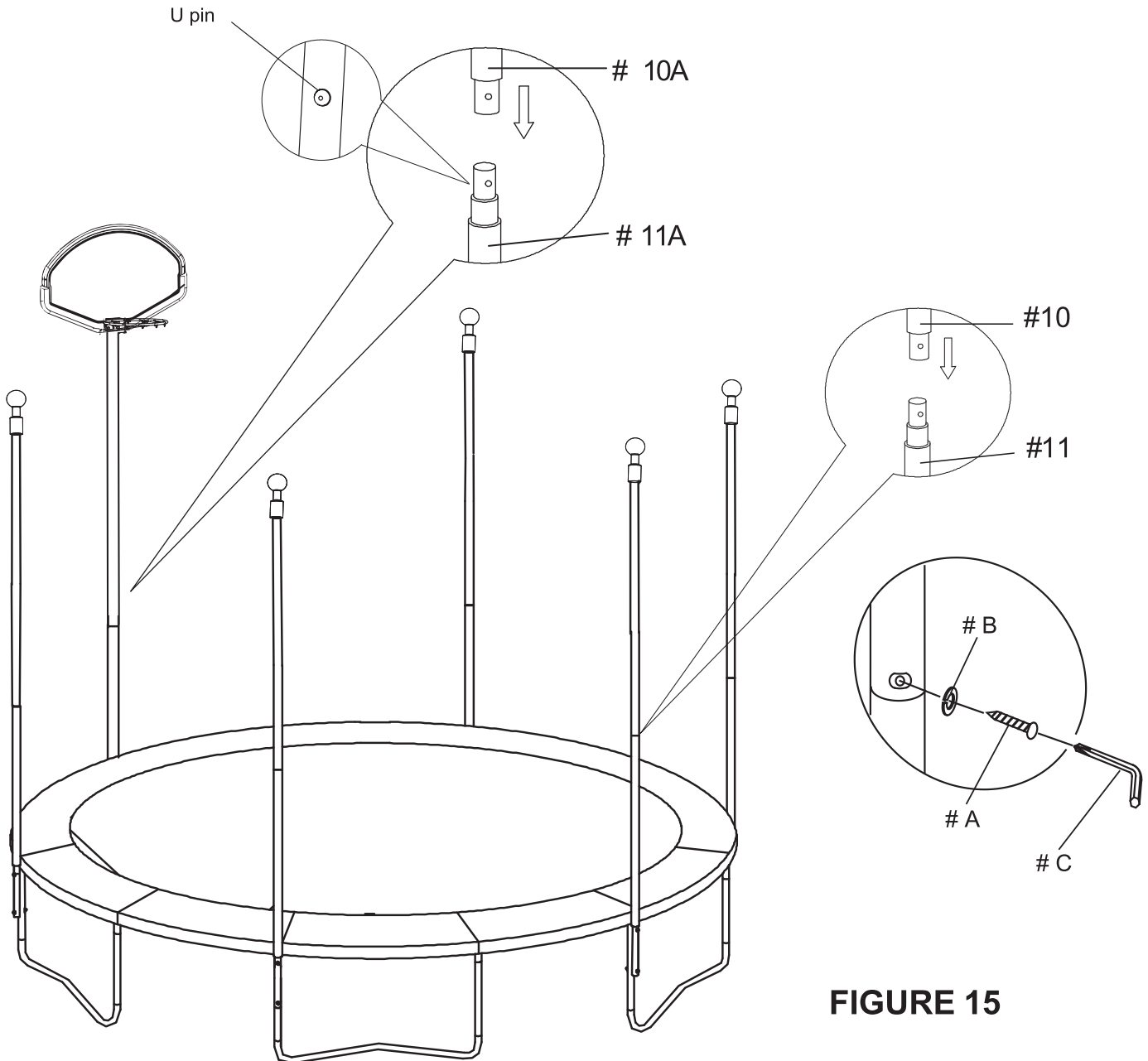

FIGURE 15

Connect Top Frame Tube (#10) and Bottom Frame Tube (#11) with screw (#A), Small Spring Wahser (#B) and Allen tool (#C)

Install the strap circle to the top of the frame (# K1) as shown and then tie the other end of the strap to the top(# K1). Please make sure the door is closing at the zero point

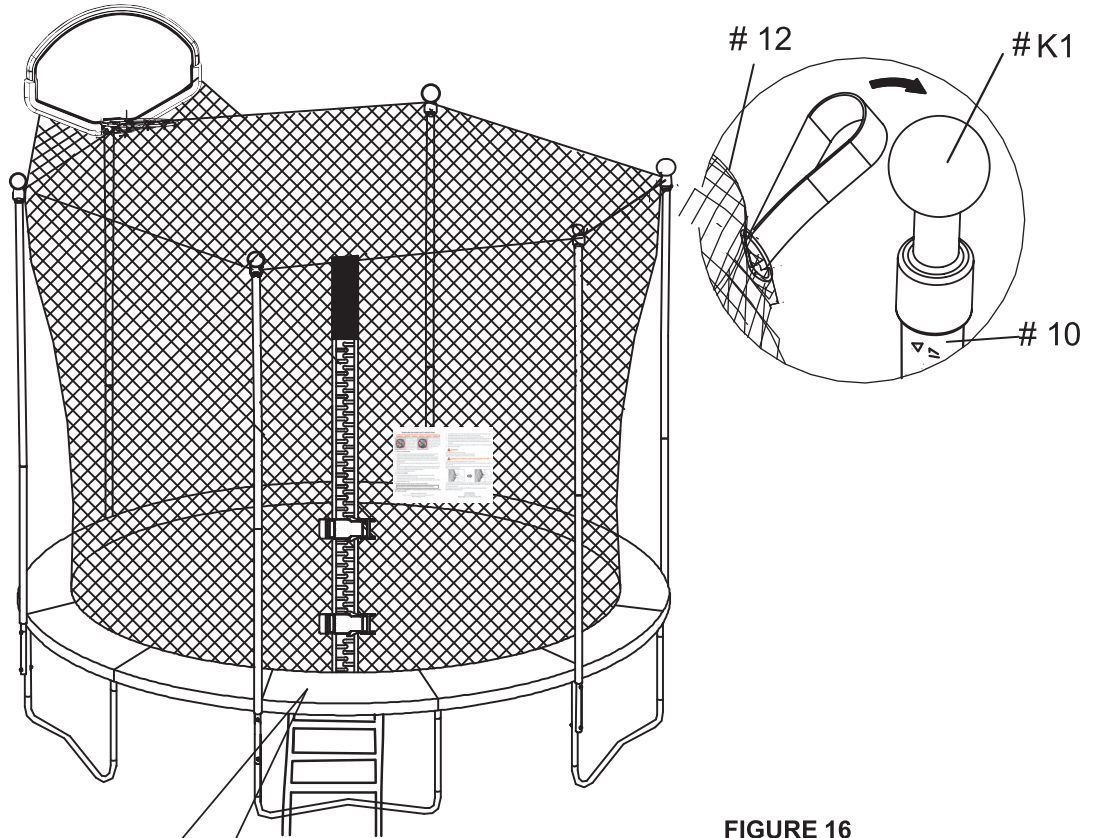
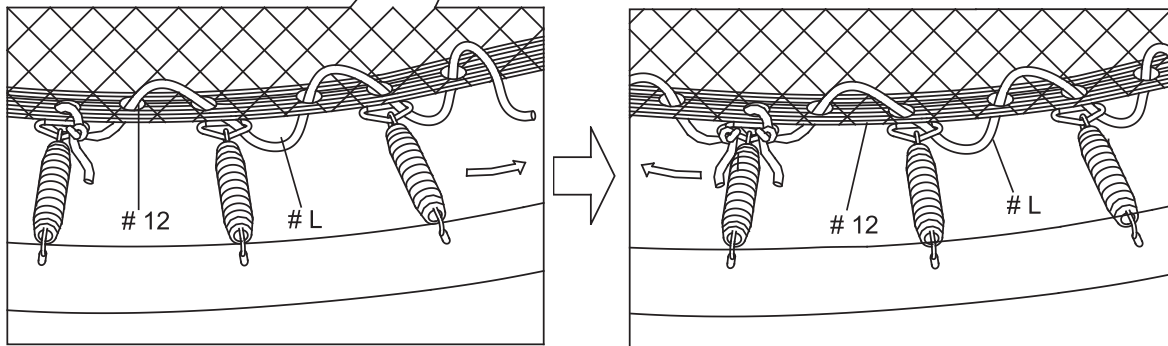

FIGURE 16



Step 16

Tie the end of the cable (# L) to the first ring of the trampoline, pull cord (# L) through all the rings on the trampoline frame, then tie the two ends of the rope together.

Step 17

Pull the trampoline enclosure (# 12) to the door, then press two buckles as (the bottom of the buckle not shown) shown in FIGURE 17.

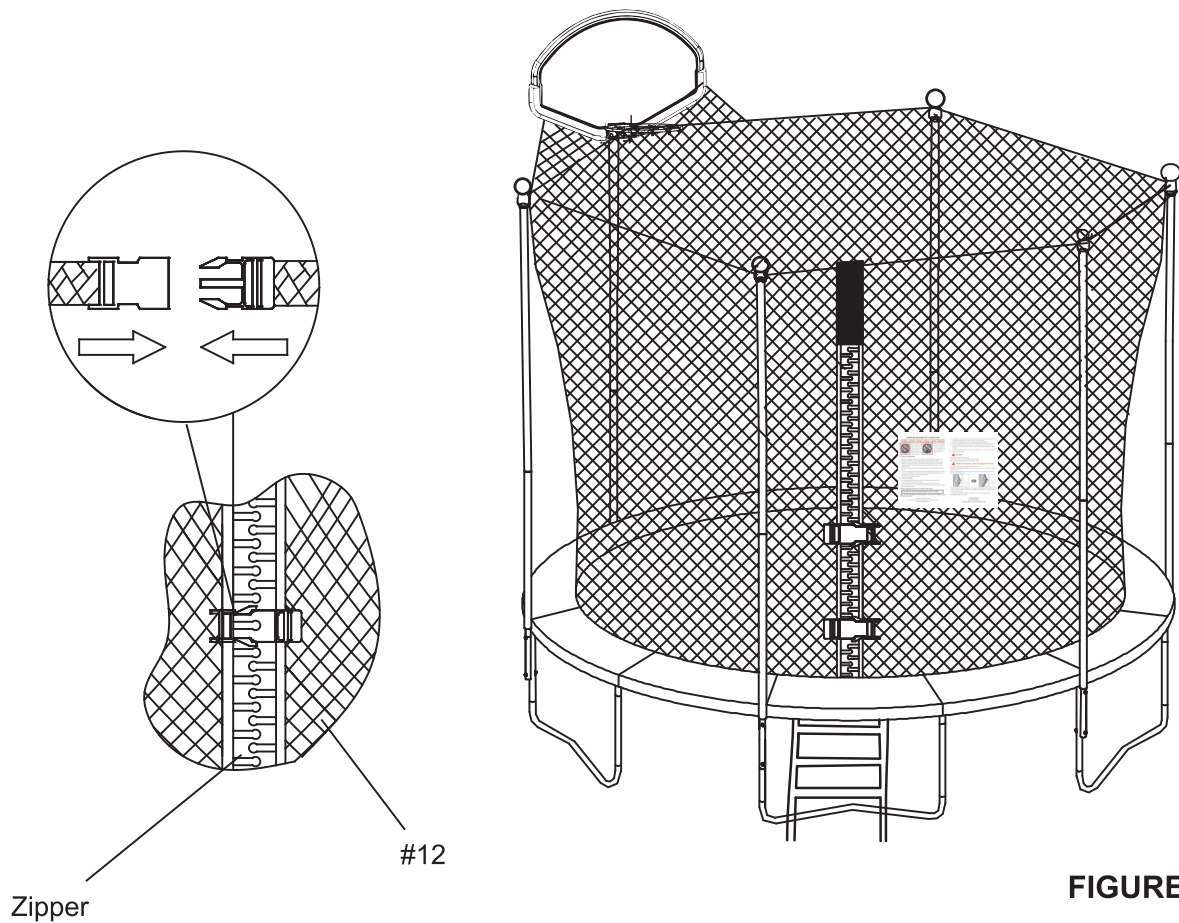

Make sure the trampoline is on a flat, level surface with adequate safety distances in case you need to move from place to place. If you have to remove the trampoline please follow the assembly instructions in reverse and take special care to keep the parts. Keep the original packaging for transport.

TRAMPOLINE AND ENCLOSURE CARE AND MAINTENANCE

To avoid damage to the trampoline and enclosure, do not allow pets or animals inside the enclosure.

The trampoline is intended to be used by one person at a time who weighs not more than 300 pounds. The user should be either barefoot, wearing socks, or wearing gymnastic shoes. Street shoes or tennis shoes should not be worn on the trampoline. The user should remove all sharp objects from his or her person that may cause injury or damage to the mat. Heavy, sharp, or pointed hard objects should never touch the mat.

Continued exposure over a long period of time to the sun, especially to ultraviolet rays, will shorten the life of the enclosure fabric. For longer fabric life, store the enclosure when it is not being used. A dry enclosure, properly stored, will provide the longest life of the fabric, sewing, and hardware. Remove the enclosure from the trampoline during harsh weather conditions or during long periods of non-use.

MAINTENANCE

Your trampoline was manufactured using quality materials and crafted to provide you and your family with many years of enjoyment and exercise. Proper maintenance and care will help to prolong the life of the trampoline and reduce the possibility of injury. The following guidelines should always be followed.

Inspect the trampoline enclosure before each use, and replace any worn, defective, or missing parts. The following conditions could represent potential hazards and increase the danger of personal injury:

- missing, improperly positioned, or insecurely attached frame padding, netting, enclosure tubes, or foam sleeves
- punctures, frays, tears, or holes worn in the mat, frame padding, netting or foam sleeves
- deterioration in the stitching or fabric of the mat, frame padding or netting
- ruptured or missing springs
- bent or broken frame, leg or enclosure tubes
- sagging bed or netting
- sharp protrusions on the frame, suspension system or enclosure tubes

If any of these conditions exist, the trampoline and/or enclosure should be disassembled (taken apart) or otherwise protected from being used until the condition is fixed.

SPECIAL CONSIDERATIONS

High Wind

It is possible for the trampoline and enclosure to be blown about by high winds. If you expect high winds, move the trampoline and enclosure to a sheltered location. Disassemble (take down) the enclosure netting. Tie the trampoline frame down to the ground using ropes and stakes (not included). At least three ropes and three stakes should be used. Make sure to attach the ropes to the top of the trampoline frame: do not simply secure the legs or the bases to the ground as they can separate from the frame sockets. The tops of the stakes should be at ground level so that they will not create a tripping hazard. In addition, the tops of the stakes should be covered, if necessary, so that users will not be hurt by falling onto the stakes.

Moving the Trampoline and Enclosure

If the trampoline and enclosure needs to be moved, it should be moved by two persons, kept horizontal, and lifted slightly. If necessary, the trampoline and enclosure can be taken apart for moving. To take the trampoline apart, follow the assembly steps in reverse order (see pages 13 to 20). Do not attempt to take the frame sections, legs, or bases apart before the mat and springs have been removed.

BASIC TRAMPOLINE SKILLS

Fundamental Bounce

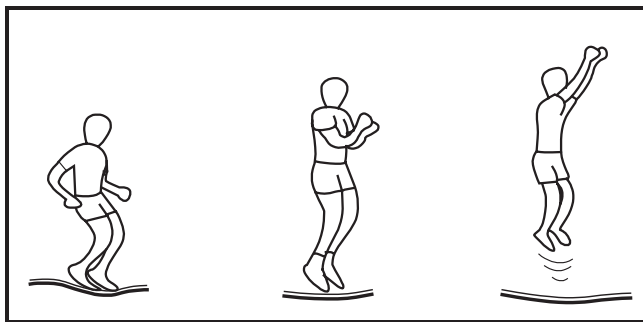

1. Start from a standing position with your head erect and your eyes on the frame pad.
2. Swing your arms forward and up in a circular motion.
3. Bring your feet together and point your toes downward while in the air.
4. Keep your feet about 15 inches apart when landing on the mat.

Knee Drop

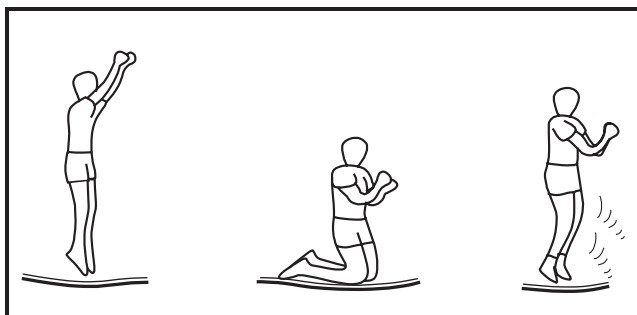

1. Start bouncing from a standing position, keeping your eyes on the frame pad.
2. Land on your knees, keeping your back straight and your body erect.
3. Come back up to an erect position.

Seat Drop

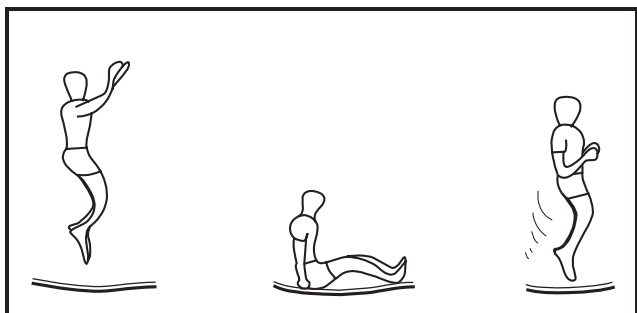

1. Land in a sitting position with your legs parallel to the mat.
2. Place your hands on the mat beside your hips.
3. Push with your hands to return to an erect position.

Front Drop

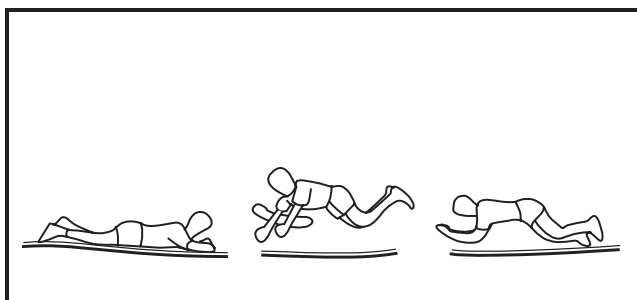

1. Start from a low bounce and land on the mat in a prone position.
2. Keep your head up and your arms extended forward on the mat.
3. Push with your arms to return to an erect position.

Installation and Assembly instructions

This trampoline and the cover can be disassembled and stored easily by Reversing the order of the installation.

At least two people are required to assemble the trampoline and cover.

Before Assemble

Before Assembly, please make sure you have all the parts required to assemble the product. If a part is missing, please contact our customer service agents.

OWNER' S MANUAL ASSEMBLY, INSTALLATION, CARE, MAINTENANCE AND USE INSTRUCTIONS

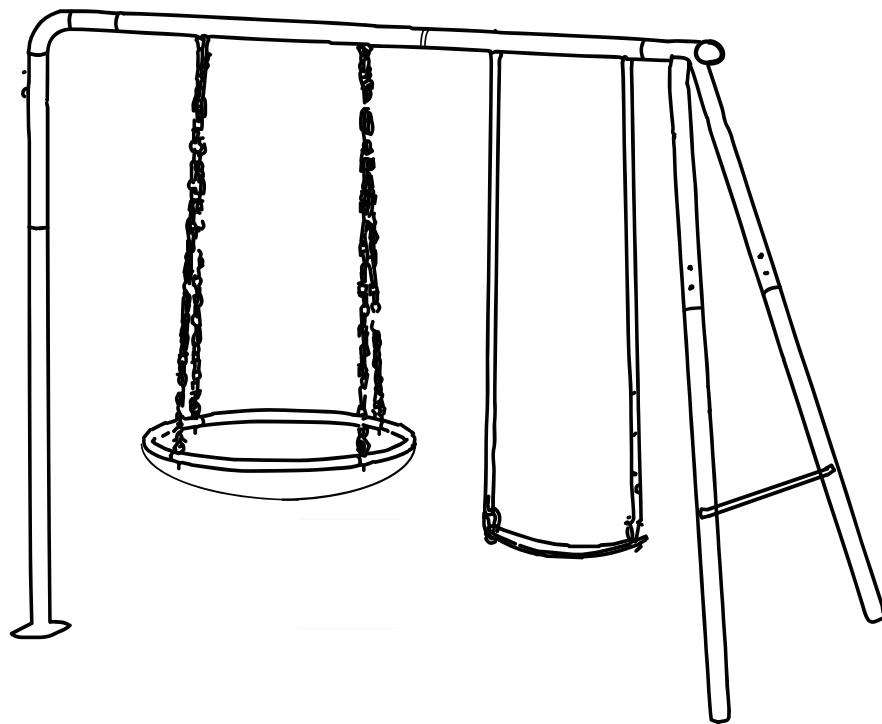

FOR RESIDENTIAL USE ONLY

















WARNING

- Misuse and abuse of this swing can cause serious injuries.
- Read instructions before using this unit.
- Inspect before use and replace any worn, defective or missing parts
- This unit is intended for use by children from 6+years old
- For outdoor family domestic use only.
- The max user weight is 40 kg.
- Adult supervision required.

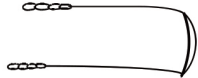









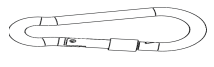





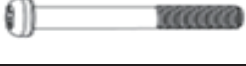

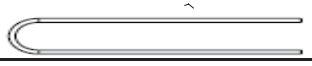
- Assembly requires at least two adults.

Save this instruction manual for future reference

Part List - Trampoline

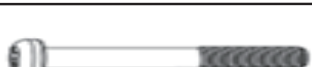
Number	Diagram	Description	Quantity
A1		Corner Joint	1
A2		Horizontal Pipe A	1
A2L		Horizontal Pipe B	1
A3		L-shaped Joint	1
A4		Welding Foot Pipe	1
A5		Foot Pipe	2
A6		Cross Bar	1
A7		Frisbee Net	1
A8		Frisbee	4
R1		Plastic Rope	4
K		Seat	1
Y2		Slide	1
X2-N		Left Handrail	1
X2-N-2		Right Handrail	1
X3-N		Small Fastener	2
X4-N		Joint Lever	1
U2		Big Fastener	2

Part list - Tools

Number	Diagram	Description	Quantity
G4		Plastic Hook	4
G2		Regulating Hook	2
B4		Plastic cover	18
B3		Lock Nut	18
B5		Arc Washer	12
B6		Washer	2
F3		Lock Nut	4
F4		Arc Washer	4
B1		Bolt	14
J6		Lock Nut	4
Q		Ground Nail	16
H5		Bolt	2
H2		Washer	10
H3		Big Spring Wahser	6
H4		Lock Nut	4
N1		Bolt	4
N2		Bolt	2
N3		Small Spring Wahser	2
N4		Washer	2
N5		Lock Nut	2

INTRODUCTION

Dear Valued Customer,

Congratulations on your Sportspower play set purchase! Please read and completely understand the contents of this owner's manual. This manual contains specific instructions and warnings that must be followed to prevent injuries.

This play set is for residential use only. This play set is NOT intended for public or commercial use. The warranty will be voided if the play set is used in a commercial application.

The product is designed for children between the ages of 3-8. Children must NOT play on this set until it is properly assembled and inspected by an adult. Adult supervision is required at all times while children are playing on the equipment. Do not allow children under six (6) years old to be near during the assembly of this product due to choking hazards of small parts.

The equipment must be installed on level ground. Uneven ground must be leveled prior to installation. Installation on sloping or uneven ground will put stress on the joints, causing the unit to become loose and unstable which may result in serious injuries. You must ensure there are no obstructions or structures (e.g. electrical wires, branches, house, fence, garage, etc) within six (6) feet from the equipment.

The Consumer Product Safety Commission's Outdoor Home Playground Safety Handbook recommend to install and maintain the playground equipment over at least 9 inches of wood chips, mulch or shredded rubber (for equipment up to 8 feet high) or sand or pea gravel (for equipment no more than 5 feet high) as shock absorbing material. Dirt and grass, which are the most prevalent surfaces under home playground equipment, do not adequately protect children from serious head injuries. Install protective surfacing at least six feet in all directions from play equipment. For swings, the surface should extend, in back and front, twice the height of the suspending bar. Do not install your play set over hard surface, e.g. asphalt, concrete, packed earth, tile or brick floor. Please refer to extracts from the CONSUMER PRODUCT SAFETY COMMISSION'S OUTDOOR HOME PLAYGROUND SAFETY HANDBOOK contained in this manual for further details.

Do not allow children to use the product during windy or wet weather conditions. It is highly recommended the product be anchored into the ground to prevent movement and to make the swing set more stable during use. You should consult a local contractor about ways to anchor the product in your location.

The equipment must be checked before each use and maintained regularly. This includes, but is not limited to inspecting the play set for cracks, excess wear, missing parts, loose connections and for overall integrity. When the equipment shows any signs of weakness or damage, you must stop using the play set immediately, properly store the set or restrict access by users until the condition is resolved.

IMPORTANT INSTRUCTIONS AND WARNINGS

WARNING

READ ALL INSTRUCTIONS BEFORE ASSEMBLING OR USING THIS EQUIPMENT

AGE LIMIT

- This product is designed to be used by up to eight (8) children between the ages of 3 to 8. Maximum user weight is 88 pounds (40kg) .
- The play set is designed for children over three (3) years of age. Use by smaller children can result in entrapment.
- On-site adult supervision is required at all times for children of all ages.
- Do not allow use by children with any physical condition that may affect his/her ability to use this equipment safely.

BEFORE YOU BEGIN

- Carefully read all instructions in this manual before assembling and using this product.
- The unit must be assembled by adults. Heavy duty working gloves must be worn to avoid injuries during assembly.
- Children must not use the equipment until it is properly assembled and anchored.
- Adult supervision is required during the use of this equipment at all times.
- Unpack all parts. Take a complete inventory of all parts and hardware using the parts and hardware lists in the following pages. If any parts are missing, do not return to the store. Please call customer service toll-free number listed on the cover page for assistance. Store the product back in the original box and do not begin to install until all parts are obtained.

LOCATION OF PLAY SET

- The equipment must be placed more than six(6) feet(1.8 meter) from any structures or obstructions, including but not limited to buildings, fence, garage, trees, laundry lines, electrical wires. Children can be seriously injured running or swinging into obstacles.
- The play set must be installed on level ground. Uneven ground must be leveled prior to installation. Installation on sloping or uneven ground will put stress on the joints, causing the unit to become loose and unstable which may result in serious injuries.
- Remove any tripping hazards from the safe play area, such as roots, tree stumps, rocks, landscaping, sprinkler heads, railroad ties, plumbing and electrical connections.

- **Do not install your play set over hard surface, e.g. asphalt, concrete, packed earth, tile or brick floor. A fall onto a hard surface can result in serious injury or death to the user.** The following is a list of recommended ground covers from the Consumer Product Safety Commission:

<u>SUGGESTED MATERIAL</u>	<u>UNCOMPRESSED DEPTH</u>
Double Shredded Bark Mulch	9"
Uniform Wood Chips	12"
Fine Gravel	12"
Fine Sand	12"

The Consumer Product Safety Commission's Outdoor Home Playground Safety Handbook recommend to install and maintain the playground equipment over at least 9 inches of wood chips, mulch or shredded rubber (for equipment up to 8 feet high) or sand or pea gravel (for equipment no more than 5 feet high) as shock absorbing material. Dirt and grass, which are the most prevalent surfaces under home playground equipment, do not adequately protect children from serious head injuries. Install protective surfacing at least six feet in all directions from play equipment. For swings, the surface should extend, in back and front, twice the height of the suspending bar. You should consult a local contractor about ways to secure the product in your location. Do not install your play set over hard surface, e.g. asphalt, concrete, packed earth, tile or brick floor. Please refer to the CONSUMER PRODUCT SAFETY COMMISSION'S OUTDOOR HOME PLAYGROUND SAFETY HANDBOOK for detailed guidelines to prevent injuries from falls and other hazards on public and home playgrounds.

WARNINGS ON ANCHORING

It is highly recommended the product be anchored into the ground to prevent movement and to make the swing set more stable during use.

Some consumers want an anchoring system that allows the product to be moved to different locations. Other consumers want to keep their swing set in a permanent location.

There are different types and different methods of anchoring this product. Sportspower does not make a specific anchoring recommendation as each consumer's need and conditions can vary.

It is highly recommended that you seek the opinion from a local licensed contractor on the best way to secure the swing set in your location. The best way to anchor a product is to create a concrete footing and use that as a base for an anchor. Whatever method you prefer for your location, an anchoring system for this product should be used at all times.

WEATHER CONDITIONS

- DO NOT use this equipment if the swing seat, slide or any parts are wet. Use the play set only when the parts are clean and dry. If the equipment is wet, the user could slip and suffer injuries.
- Please be aware of weather conditions when using the equipment. If it is too windy, users could lose control and suffer injuries. The playground equipment must be properly anchored, stored away or restricted from use during inclement weather such as heavy winds or severe weather storms. You should consult a local contractor about ways to anchor the product in your location.

PLAY SUPERVISION

- DO NOT allow more than one child to play on the individual swing, trampoline or slide component at any one time. The maximum user limit for the flying saucer and glide ride is two persons.
- DO NOT allow children to stand on the slide, swing seats or glide ride.
- DO NOT allow children to walk too close to moving parts. ALWAYS keep a safe distance to avoid being struck by other children while playing on swings, slides, trampolines etc.

- DO NOT allow children to twist the swing chains or ropes, or loop them over the top support bar as this may reduce the strength of the chain or rope.
- DO NOT swing empty seats as this may cause injuries.
- ALWAYS guide children to sit in the center of swinging parts, with their full weight placed in the seat center and holding on to the swing chains.
- DO NOT allow children to jump off the equipment while it is in motion. ALWAYS come to a full stop before dismounting.
- ALWAYS dress children appropriately for proper play, e.g. wear well-fitted rubber sole shoes, and remove loose or sharp items such as jewelry, hair accessories, scarves which may become entangled in the equipment or cause injuries.
- ALWAYS make sure children remove their bike or other sports helmets before playing on the playground.
- DO NOT allow children to slide down head first.
- DO NOT allow children to climb onto swing or jump to/from different play areas of the equipment.
- ALWAYS return safely to the ground before approaching another play area.
- DO NOT allow children to climb on structural parts (e.g. legs, top bar). These are structural components and are not designed for play.
- ALWAYS check the slide or other parts exposed to the body for extreme heat from the sun before allowing children to use the equipment.
- ALWAYS prevent access and secure from any unauthorized use when there is no adult supervision.
- DO NOT allow pets or other animals near the equipment to prevent damage or injuries.
- Adequate overhead clearance is essential. A minimum of 24 ft (7.3 meters) from ground level is recommended. Provide clearance for wires, tree limbs, and other possible hazards.
- Use the trampoline in a well-lit area. Artificial illumination may be required for shady areas.

TRAMPOLINE WARNINGS

- Do not allow more than one person on the trampoline at a time. Multiple users can cause loss of control, collision or falls that could result in serious injury.
- Jumpers should remove their shoes and wear either socks or be barefoot when using the trampoline.
- Do not jump onto the trampoline. Carefully step on and off the trampoline mat. Do not use the trampoline as a springboard to other objects. Do not jump to or from the trampoline to the flying saucer or any other component of the swing set.
- Avoid bouncing too high. Maintain control of the bounce and focus on landing in the center of the trampoline.
- Bounce only when the surface of the mat is dry. Do not use during wet or windy conditions.
- Never use the trampoline without the frame padding properly secured and fully covering the frame.
- Remove any obstructions from beneath the trampoline before each use.
- Do not allow any pets onto the trampoline as the mat may be damaged.
- Any type of sharp or pointed objects must be kept off the trampoline mat at all times.
- Always inspect the trampoline before each use and replace any worn, defective or missing parts. Please make sure to check following conditions that could represent potential hazards before using:
 - Missing, improperly positioned, damaged or insecurely attached frame padding.
 - Punctures, frays, tears or holes worn in the bed or frame padding.
 - Deterioration in the stitching or fabric of the bed or frame padding.
 - Broken, missing or damaged springs.
 - A bent or broken frame.

- A sagging, broken bed.
- Sharp protrusions on the frame or suspension system.
- Protrusions of any types (especially sharp typed) on the frame, springs or mat.
- Loose stitching or any kind of deterioration of the mat.

If any of the above conditions exist, restrict use until proper repairs or replacements are made.

- Do NOT attempt or allow somersaults. Landing on the head and neck can cause serious injury, paralysis, or death, even when landing in the middle of the mat.
- Use trampoline only with mature, knowledgeable supervision.
- Step on and off the trampoline. It is a dangerous practice to jump from the trampoline to the floor or ground when dismounting, or to jump onto the trampoline when mounting.
- Stop bounce by flexing knees as feet come in contact with the mat. Learn this skill before attempting others.
- Learn fundamental bounces and body positions thoroughly before trying more advanced skills. A variety of trampoline activities can be carried out by performing the basic fundamentals in various series and combinations, performing one fundamental after another, with or without feet bounces between them.
- Control is more important than height.
- While keeping the head erect, focus eyes on the trampoline toward the perimeter. This will help control bounce.
- Avoid bouncing when tired. Keep turns short.
- Properly secure the trampoline when not in use. Protect it against unauthorized use. Keep objects away which could interfere with the performer. Maintain a clear area around the trampoline.

Responsibilities of the user

The key here is to stay in control of your jumps. DO NOT move onto more complicated, more difficult maneuvers until you have mastered the basic, fundamental bounce. Read, understand, and practice all precautions and warnings prior to using the trampoline. A controlled jump is when you land and take off from the same location. For additional tips and instructions, contact a certified trampoline instructor.

Supervisor's or owner's role in preventing injuries

It is the responsibility of the supervisor(s) of the trampoline users to provide knowledgeable and mature supervision. They need to know and enforce all the rules and warnings set forth in this manual in order to minimize the likelihood of accidents and injuries and to inform users of these rules. During the periods of time when supervision is unavailable or inadequate, the trampoline should be disassembled and stored in a secure place to prevent unauthorized use. The supervisor is also responsible to ensure that the safety placard is placed on the trampoline and that the jumpers are informed of these warnings and instructions.

IMPORTANT

CONSUMER INFORMATION SHEET

The Consumer Product Safety Commission estimates there are more than 200,000 playground related injuries involving children each year. Injuries involving this hazard pattern tend to be among the most serious of all playground injuries and have the potential to be fatal, particularly when the injury is to the head. The surface under and around playground equipment can be a major factor in determining the injury-causing potential of a fall. It is self evident that a fall onto a shock absorbing surface is less likely to cause a serious injury than a fall onto a hard surface. Playground equipment should never be placed on hard surfaces such as concrete or asphalt and while grass may appear to be acceptable it may quickly turn to hard packed earth in areas of high traffic. Shredded bark, mulch,,wood chips, fine sand or fine gravel are considered to be acceptable shock absorbing surface when installed and maintained at a sufficient depth under and around playground equipment.

Table below lists the maximum height from which a child would not be expected to sustain a life-threatening head injury in a fall onto four different loose-fill surfacing materials if they are installed and maintained at depths of 6" (15.25CM), 9" (22.9CM), and 12" (30.5CM).

FALL HEIGHT IN FEET FROM WHICH A LIFE THREAENING HEAD INJURY WOULD NOT BE EXPECTED			
TYPE OF MATERIAL	6" (15.25CM) DEPTH	9" (22.9CM) DEPTH	12" (30.5CM) DEPTH
Double shredded bark mulch	6" (15.25CM)	10" (25.4CM)	11" (27.94CM)
Wood Chips	6" (15.25CM)	7" (17.8CM)	12" (30.5CM)
Fine Sand	5" (12.7CM)	5" (12.7CM)	9" (22.86CM)
Fine Gravel	6" (15.25CM)	7" (17.8CM)	10" (25.4CM)

However, it should be recognized that all injuries due to falls cannot be prevented no matter what surfacing material is used.

We recommend that a shock absorbing material should extend a minimum of 6ft in all directions from the perimeter of stationary equipment such as climbers and slides. However, because children may deliberately jump from a moving swing, the shock absorbing material should extend in the front and rear of a swing a minimum distance of 2 times the height of the pivot point measured from a point directly beneath the pivot on the supporting structure.

This information is intended to assist in comparing the relative shock-absorbing properties of various materials. No particular material is recommended over another. However, each material is only effective when Properly maintained. Materials should be checked periodically and replenished to maintain correct depth as determined necessary for your equipment. The choice of a material depends on the type and height of the playground equipment, the availability o the material in your area and its cost.

Note: The maximum fall height for this product is 6 feet. The minimum ground Clearance between the bottom of the suspended plays and the playing or ground service must be 8 inches.

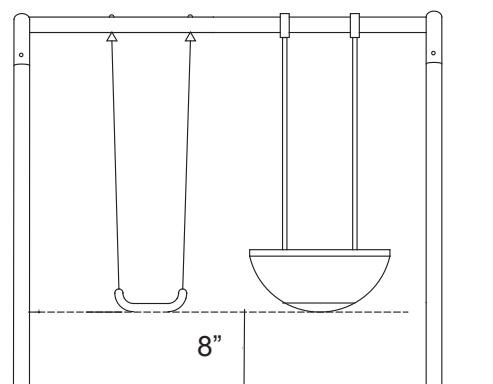

ANCHORING

(NOTE: ANCHORS ARE NOT INCLUDED-MUST BE PURCHASED SEPARATELY)

There are different ways of anchoring the equipment, depending on the type of ground on which the equipment is to be installed. Make sure that all anchors are below ground level to prevent tripping.

You should consult your local contractor to decide the most appropriate way to anchor the equipment in your location.

The following anchoring options may be considered:

Corkscrew Anchoring (Corkscrew Anchors not included)

- If your soil is hard (clay, etc.), the corkscrew method may be suitable.
- Be sure that the swing set is located on level ground.
- Twist the corkscrew anchor into the ground until only the end with the hook is above the ground and next to the leg. Insert the hook into the bottom opening of the leg. Ensure that the hook is secured onto the leg opening.

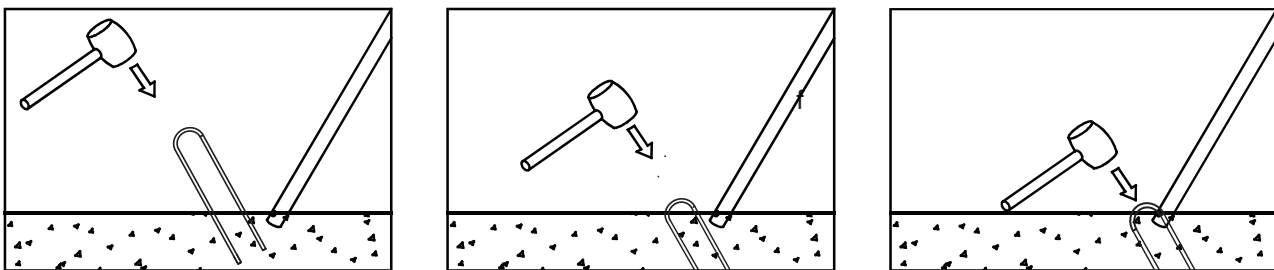

Concrete Anchoring (Materials not included)

- If the swing set is set up on grounds with sandy soil (soft) condition, it must be anchored with concrete footing (concrete not included)
- Be sure that the swing set is assembled and placed on level ground
- Dig holes around swing leg tube, as shown in drawing in the next page. As you dig deeper, enlarge the diameter of the hole to fix the cement
- Place 2 inches of brick or gravel underneath the leg, as shown in drawing in the next page
- Use about 45 lbs. of concrete per leg
- Cover the concrete with dirt and protective surface material
- Allow 6-7 days for the concrete to dry properly

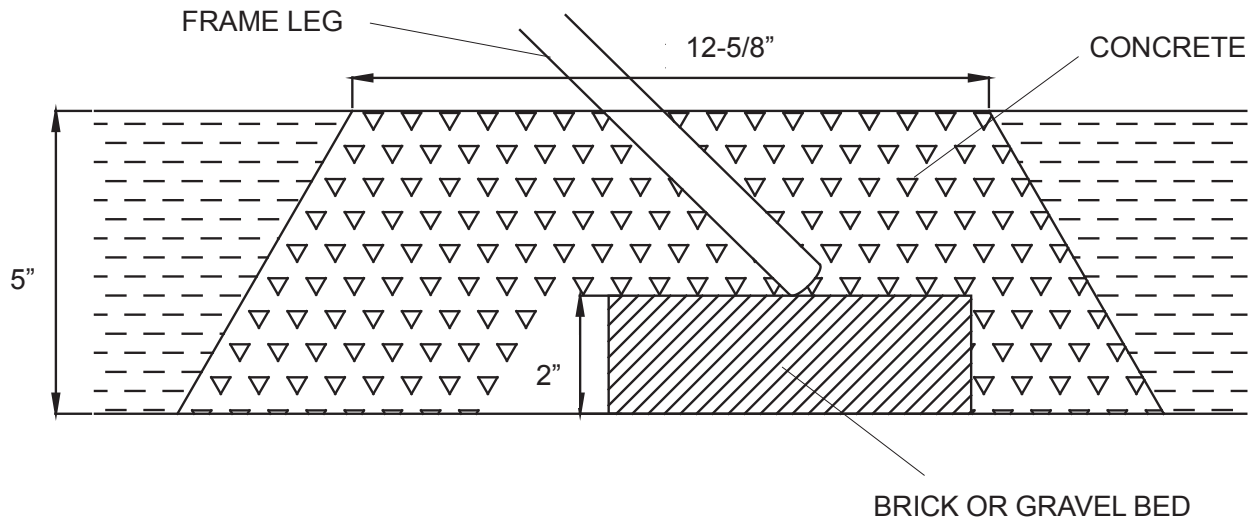

Note: The maximum fall height for this product is 6 feet. The minimum ground clearance between the bottom of the suspended plays and the playing or ground surface must be 8 inches.

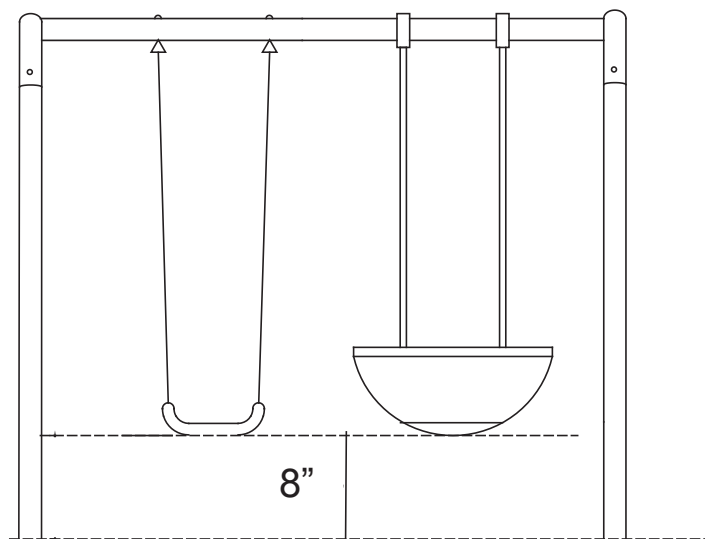

You must maintain a minimum of 8 inches of ground clearance.

⚠ WARNING

Please properly anchor the swing set to minimize the risk of injury or death. If the swing set is used without proper anchoring, it may be dangerous and may tilt over.

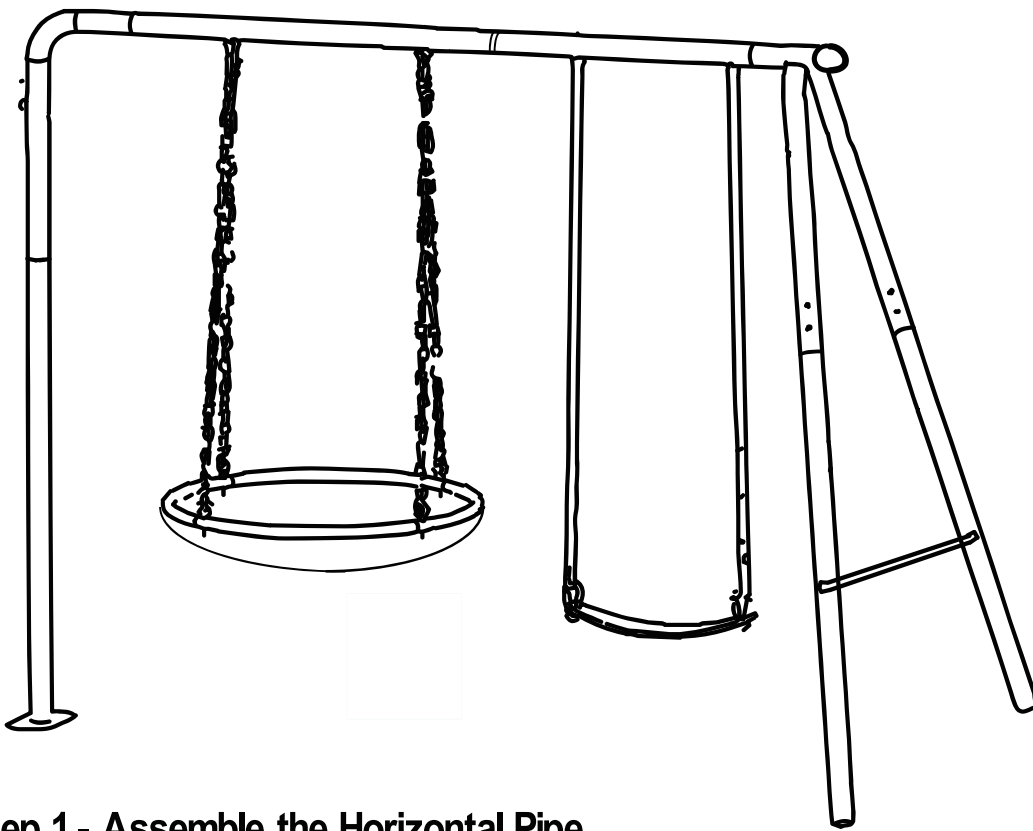

Step 1 - Assemble the Horizontal Pipe

Take out the horizontal pipes (A2, A2L). Insert the end of A2L marked with ① into the end of A2 marked with ①. The arc of A2 and A2L should be upward. (The concave holes on A2 and A2L should be downward).

Take out parts numbered with B1, B3, B4, B5 from the screw package, and assemble them as shown below.

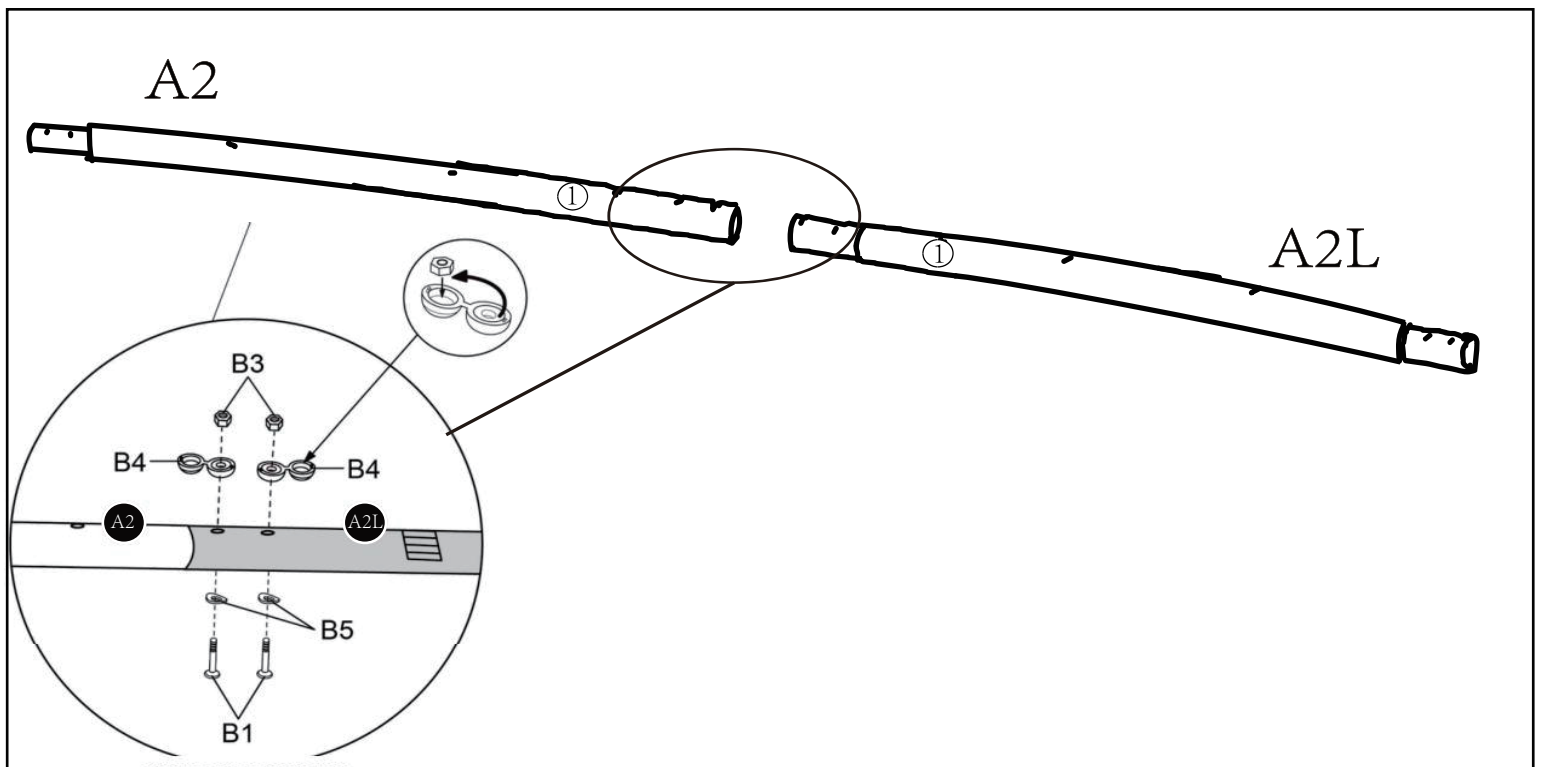

Step 2 - Assemble the Joint

Take out the 2 types of corner (A1, A3). Insert the end of A2 marked with ② into the end of A3 marked with ②, and insert the end of A2L marked with ③ into the end of A3 marked with ③.

Take out parts numbered with B1, B3, B4, B5 from the screw package, and assemble them as shown below.

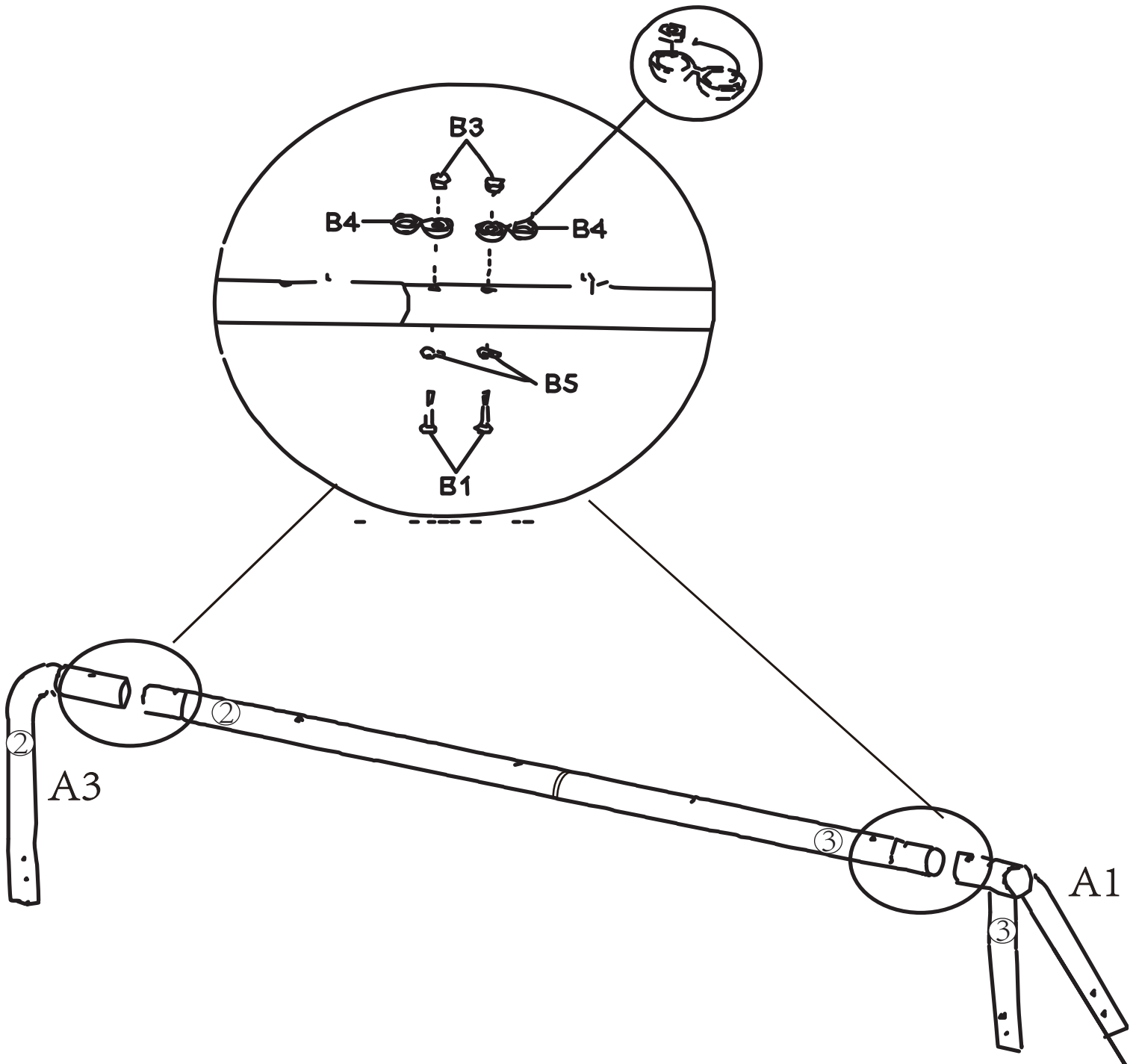

Step 3 – Assemble the Foot Pipe

Take out the foot pipes (A4, A5). Connect the contracted end of A4 with A3 and the end of A5 with A1. When the swing is up, take out parts numbered with B1, B3, B4, B5 from the screw package, and assemble them as shown below.

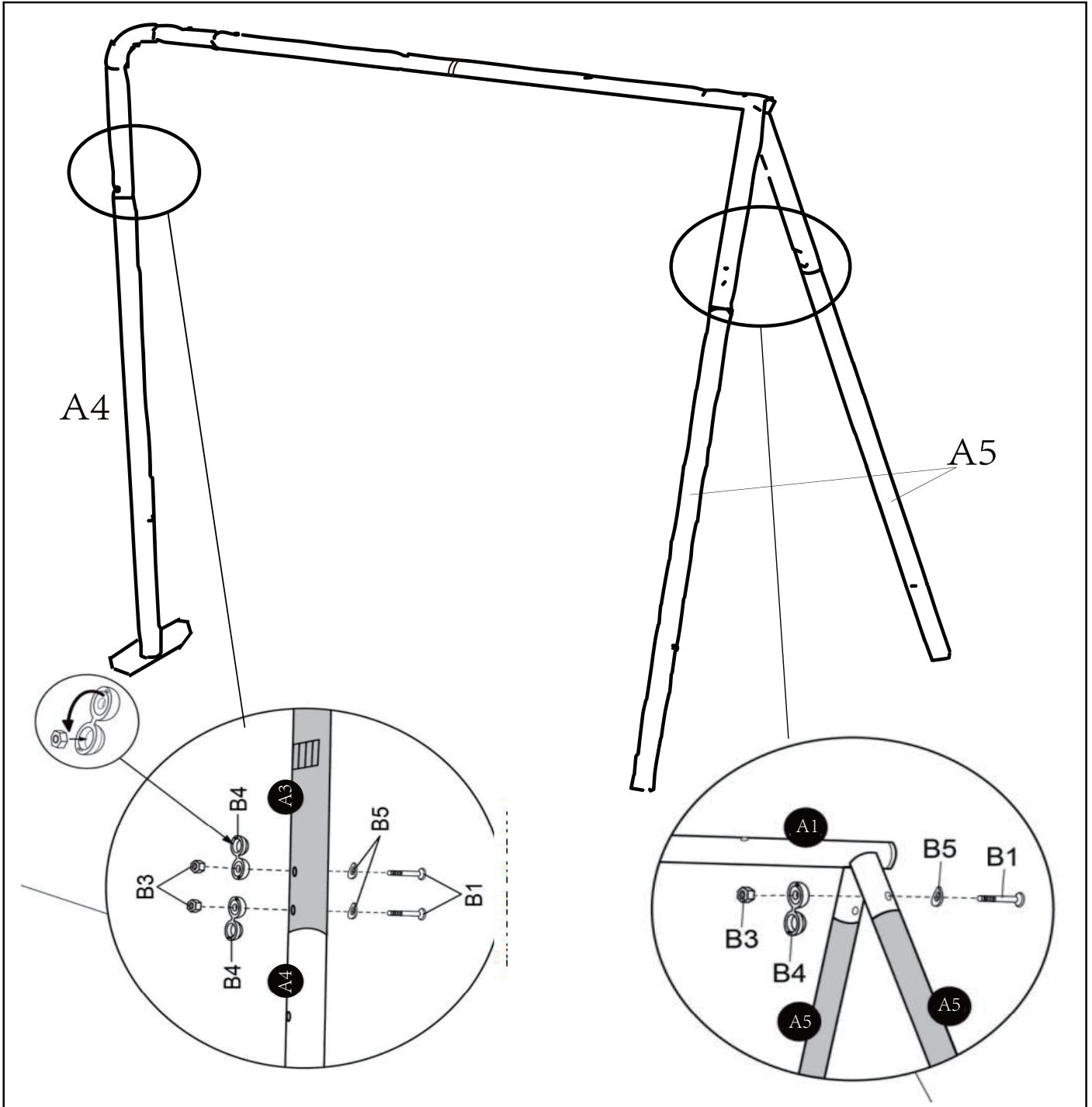

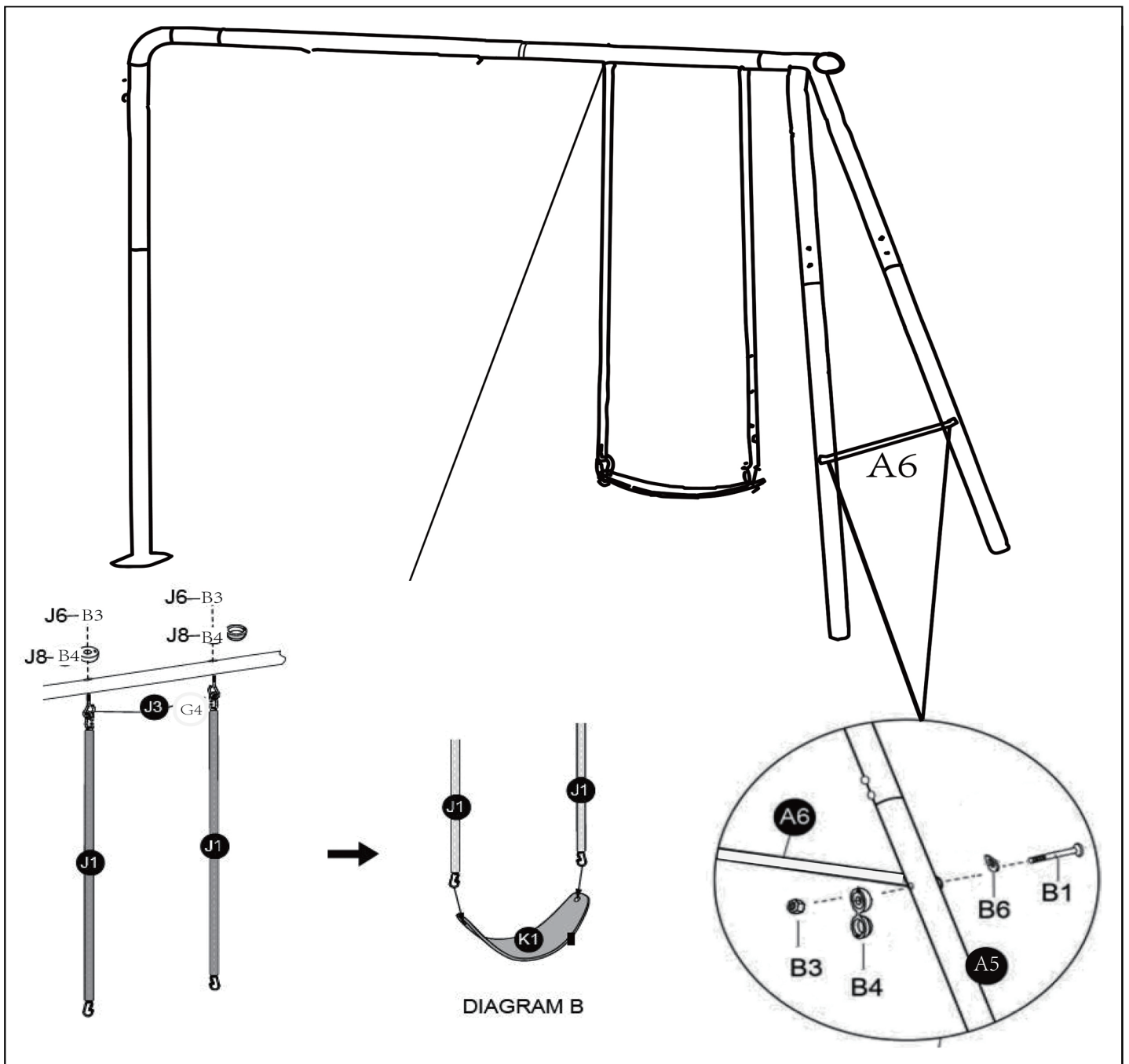

Step 4 - Assemble the Swing Seat

Take out the seat cushion (K) and install it in the corresponding position according to the diagram above (install through two concave holes on A2L). Take out the cross bar (A6), and install it as the diagram above. The flattened part of the cross bar shall be installed outward

Step 5 - Assemble the Frisbee

Take out the four frisbees (A8) and install them into the frisbee net (A7), then connect the frisbee head with next frisbee tail to form a circle. Take out the four plastic ropes (R1), and each two are connected with the movable split ring (G2). The split ring (G2) is connected with the plastic-coated hook (G4), and G4 is connected with lock nut (B3) and plastic cover (B4) through the concave holes on A2. The small hook (G3) on the other end of plastic rope (R1) is connected with arc washer (F4) and lock nut (F3) through the holes on frisbee (A8). Install them as shown below.

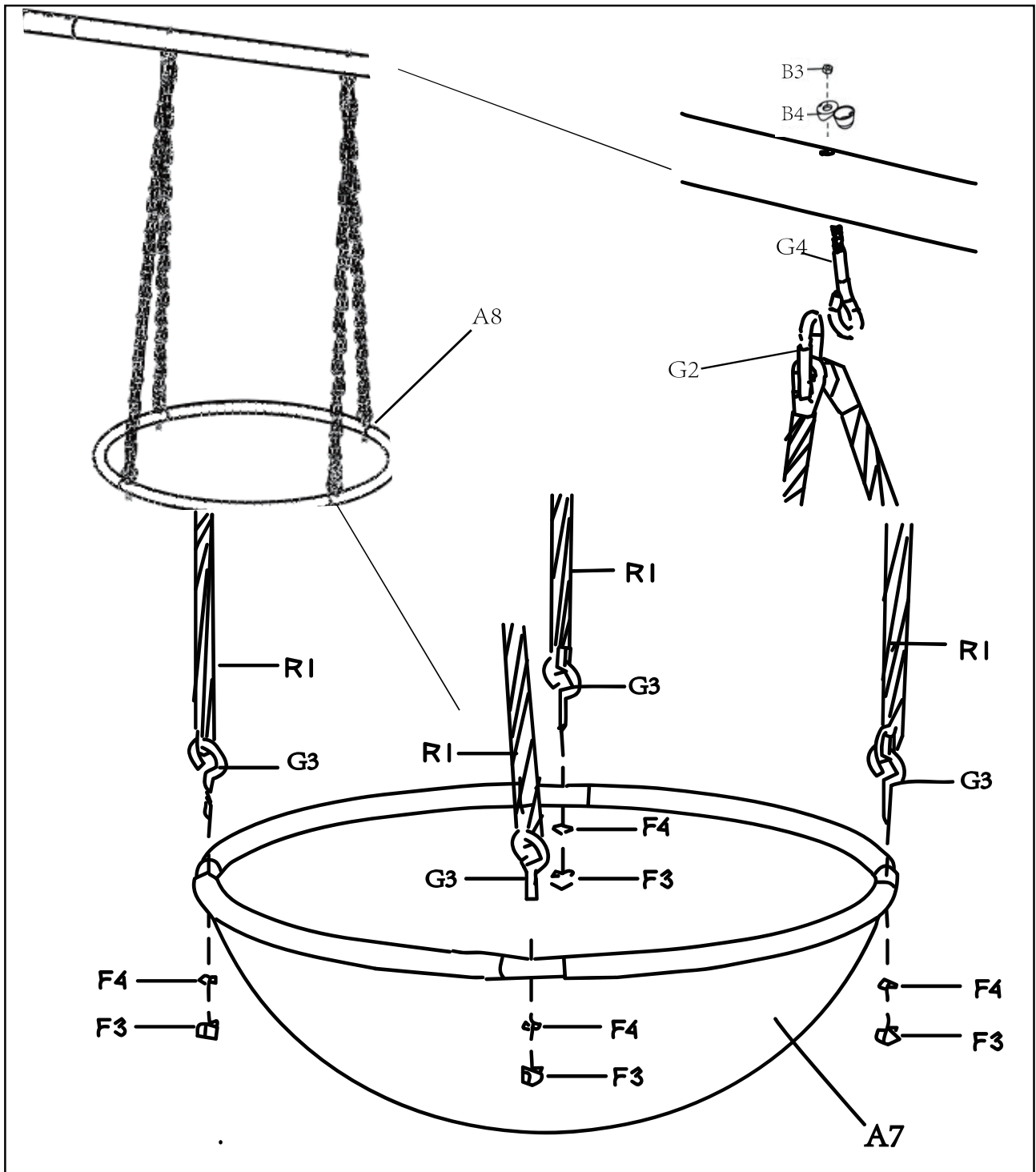

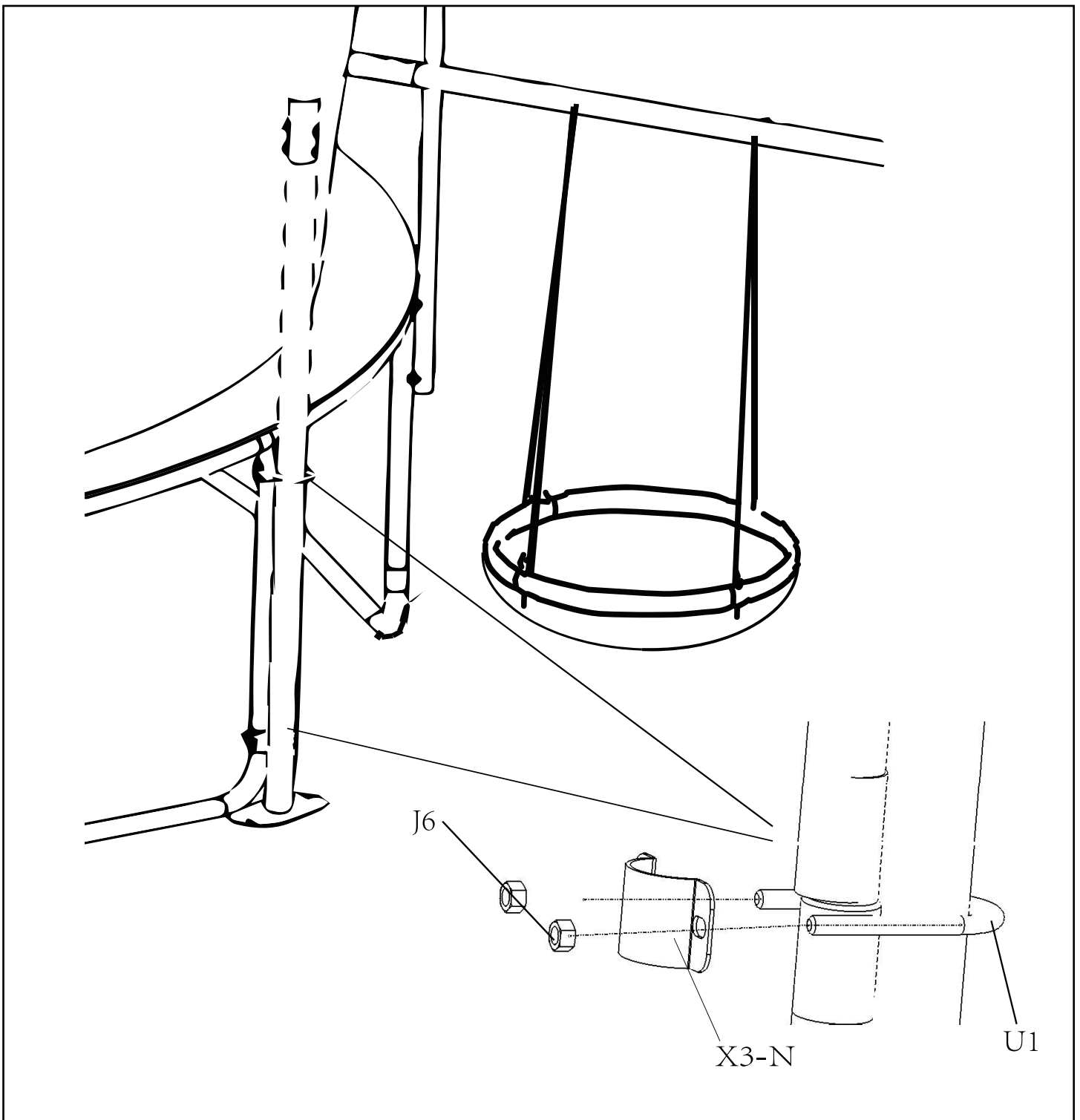

Step 6 - Connect the Swing with the Trampoline

Take out the small fastener (X3-N), U-shaped screw (U1), and nut (J6). Lock the foot tube (A4) of the swing to the vertical extension leg of the trampoline by connecting u-shaped screw (U1) with small fastener (X3-N). (lock the head and tail part of the vertical extension leg to the foot tube respectively)

Note: the position where the swing and trampoline are connected is opposite to the slide, that is, the enclosure net door that does not face the backboard.

Step 7 - Prepare the Slide Assembly

Take out the joint lever (X4-N), left handrail (X2-N), right handrail (right handrail) and slide (Y2) to prepare for the assembly as the following figure shows. Put the big holes of left handrail (X2-N) and right handrail (X2-N-2) face inward, and connect them with joint lever (X4-N).

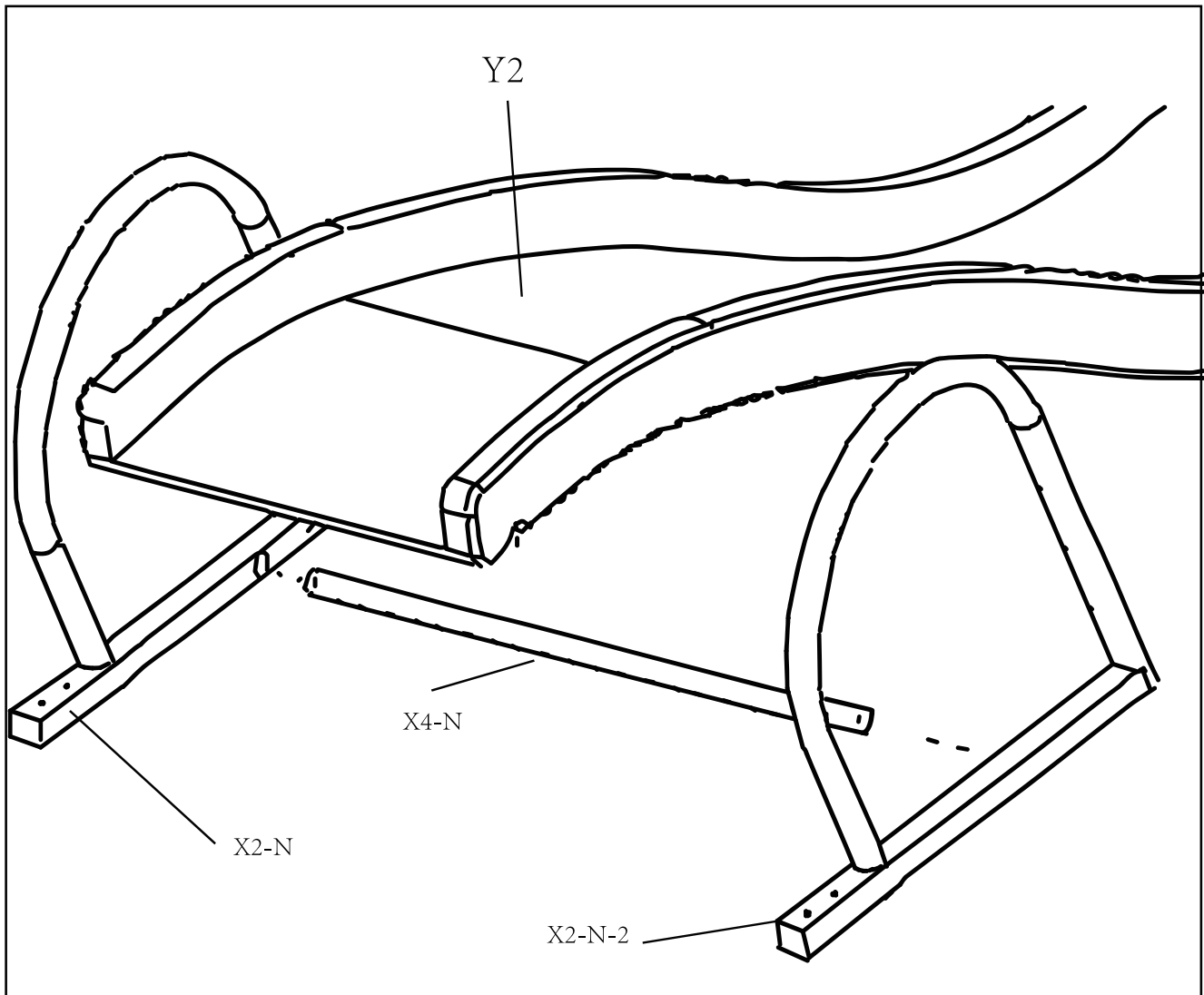

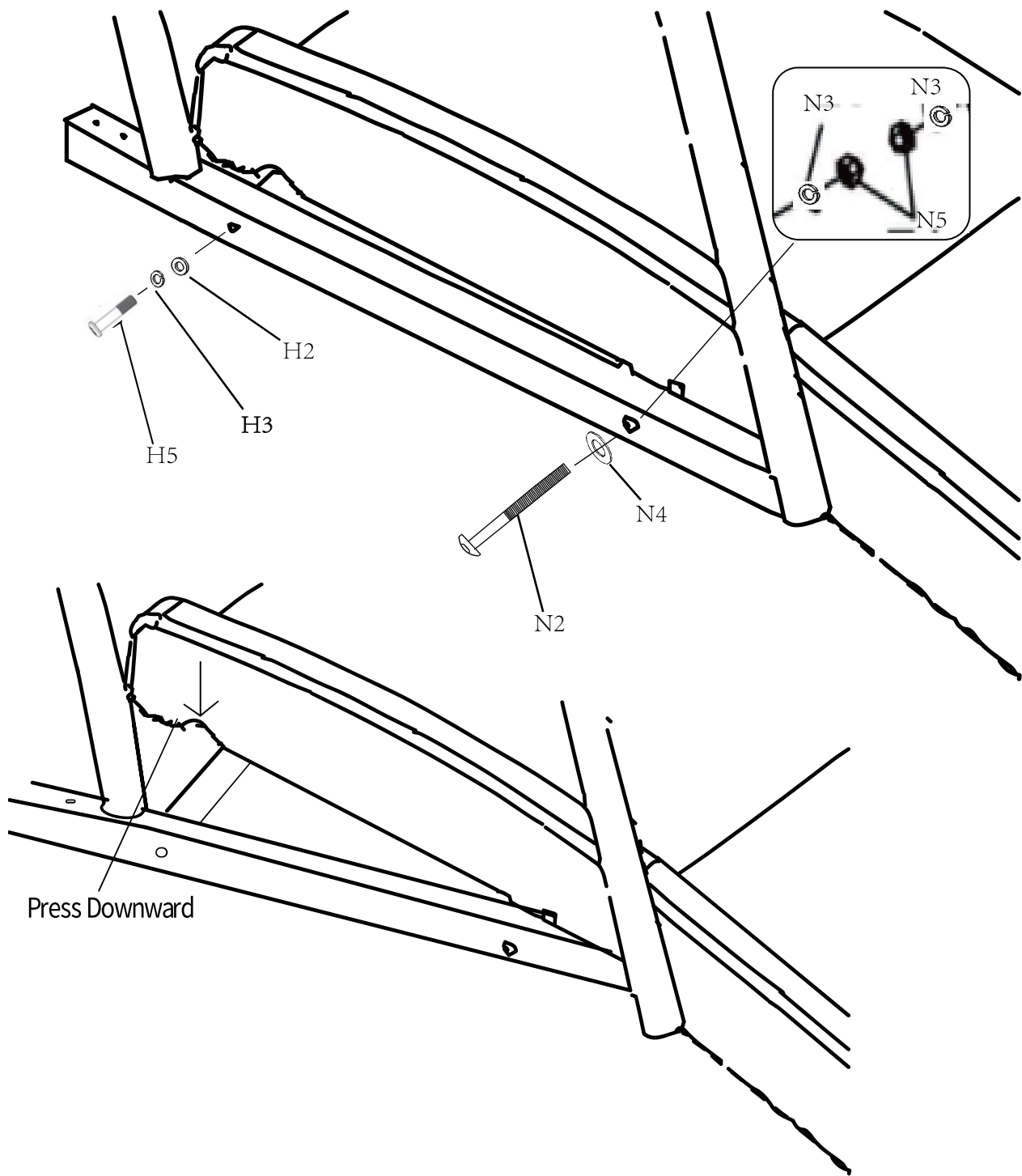

Step 8 - Assemble the Slide

Take out the bolt (H5), washer (H2) and big spring washer (H3), and assemble the joint lever (X4-N) with these parts. The assembly of the left and right handrails are the same. Take out the bolt (N2), small spring washer (N3), washer (N4) and lock nut (N5), and connect the slide (pass the bolt (N2) and washer (N3) through the holes on the slide, and fasten them with small spring washer (N3) and lock nut (N5)), finally press the groove on the slide into the joint lever (X4N). As shown in above figure

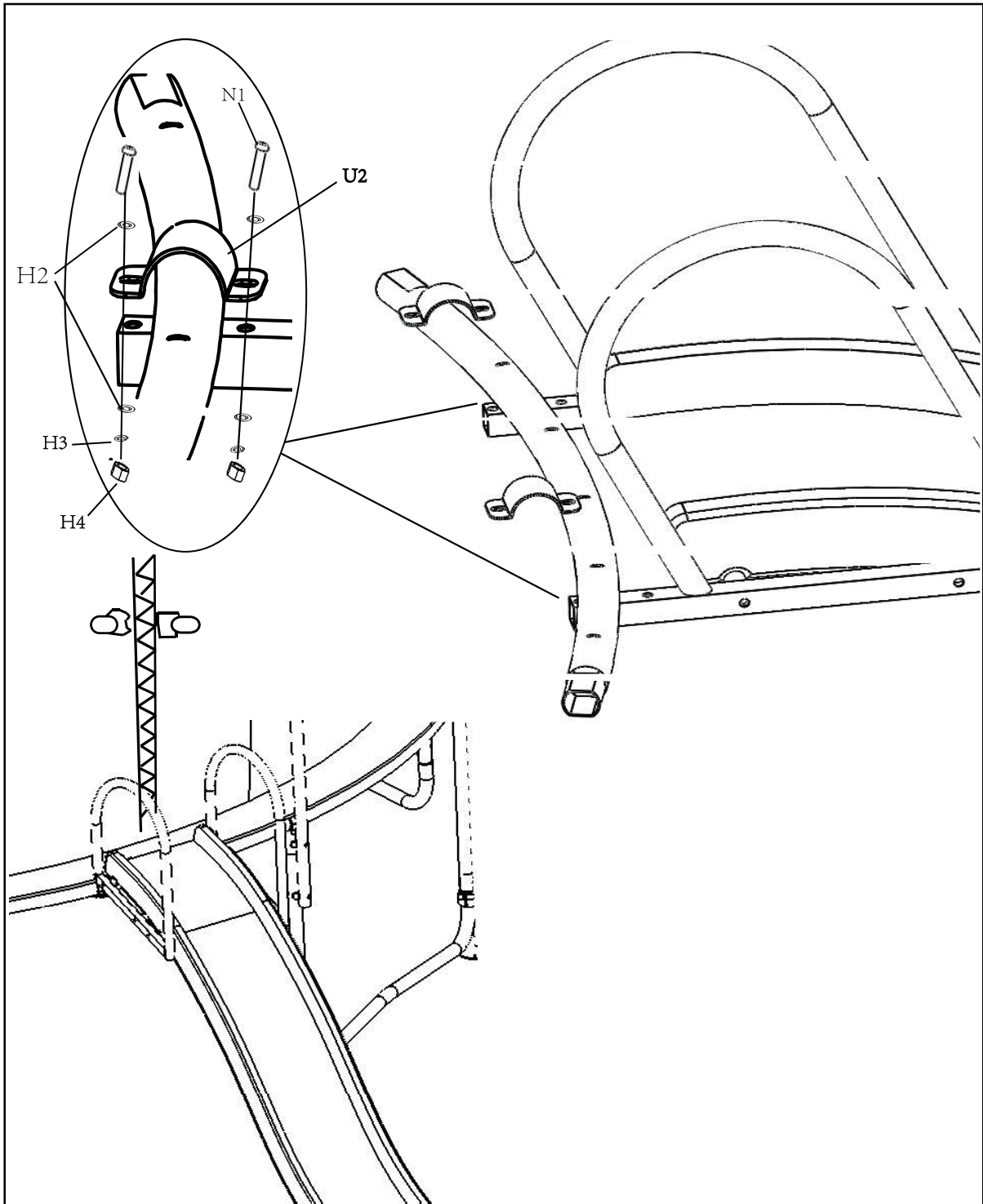

Step 9 - Connect the Slide with Trampoline

Connect the slide with the trampoline at the position of enclosure door, which is also the opposite of the swing. Put the end of slide under the top rail, and install it through the bolt (N2) and big fastener (U2).

MANUFACTURER' S LIMITED WARRANTY

Sportspower Ltd warrants its products to be free from defects in material and workmanship under normal use and service conditions for ninety (90) days after the date of purchase. The frame is warranted for 12 months after the date of purchase.

This warranty coverage extends only to the original purchaser with a receipt and is nontransferable. All products for which a warranty claim is made must be received by a Sportsauthorized service center, freight prepaid, and accompanied by sufficient proof of purchase during the warranty period.

This limited warranty does not cover our products which: fail due to (1) normal wear; (2) abuse and neglect; (3) improper maintenance; (4) unauthorized repairs or alterations or (5) are used for commercial or other income producing purposes or (6) accidents and misuse.

All warranty repairs must be authorized by Sportspower Customer Service before repairs are made.

IMPORTANT: A missing part is not considered the same thing as a defective part or unit. If a part is missing, there is no need to return the entire unit to the store. In order to obtain fast replacement parts or service as provided by this warranty, please call the number below. Proof of purchase required.