

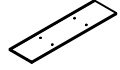





























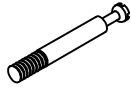

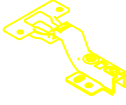
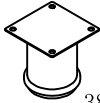

Parts List

NO.	Drawing	Dimension	QTY
1		1480*390*15mm	1
2		1378*362*15mm	1
3		415*288*15mm	1
4		400*362*15mm	1
5		400*362*15mm	1
6		415*288*15mm	1
7		540*362*15mm	1
8		1378*50*15mm	1
9		417*395*15mm	1
10		417*395*15mm	1
11		536*200*15mm	1
12		300*118*15mm	1

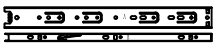
NO.	Drawing	Dimension	QTY
13		300*118*15mm	1
14		485*118*15mm	1
15		495*294*4mm	1
16		402*346*15mm	2
17		413*205*4mm	4
18		550*235*4mm	1
19		550*170*4mm	1
20		495*46*46mm	1
21		495*46*46mm	1
22		495*46*46mm	1
23		495*46*46mm	1

Hardware Fitting

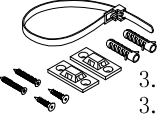
NO.	Drawing	QTY
A		40
B		40
C		28
D	 3.0*14mm	28
E		4
F	 38*85mm	2
G	 3.5*14mm	32

NO.	Drawing	QTY
H		2
I	 3.5*35mm	4
J		8
K		1
L	 3.5*35mm 3.5*14mm	2
M	 L404mm	2
N		10

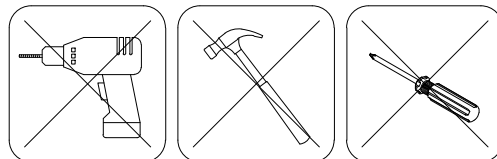

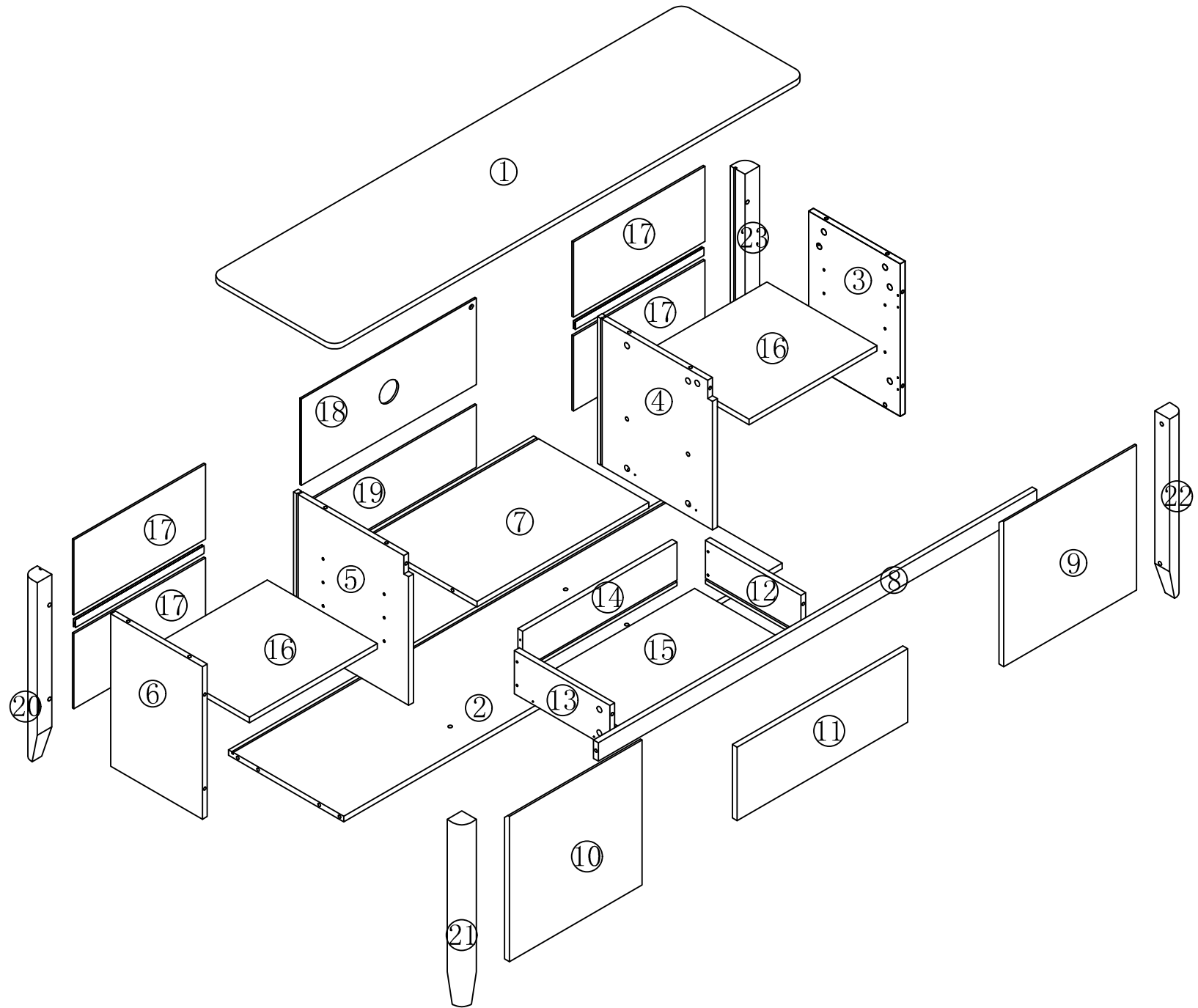

Cam Coupling Using Methods

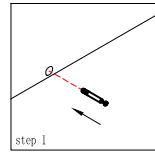

Step1.

Connect the cam coupling A as directed in the assembly instructions using hand.

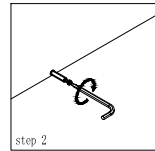

Step2.

Screw the cam coupling A as directed in the assembly instructions.

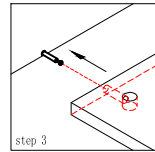

Step3.

Push the cam coupling A into the entry hole.

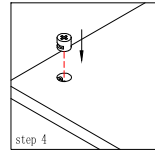

Step4.

Insert the cam coupling B as shown in the instructions.

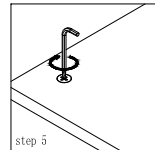

Step5.

Turn the cam coupling B clockwise with a screwdriver

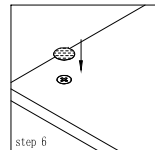

Step6.

Put on Beautycam.

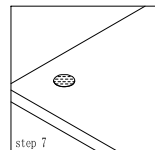



Step7.

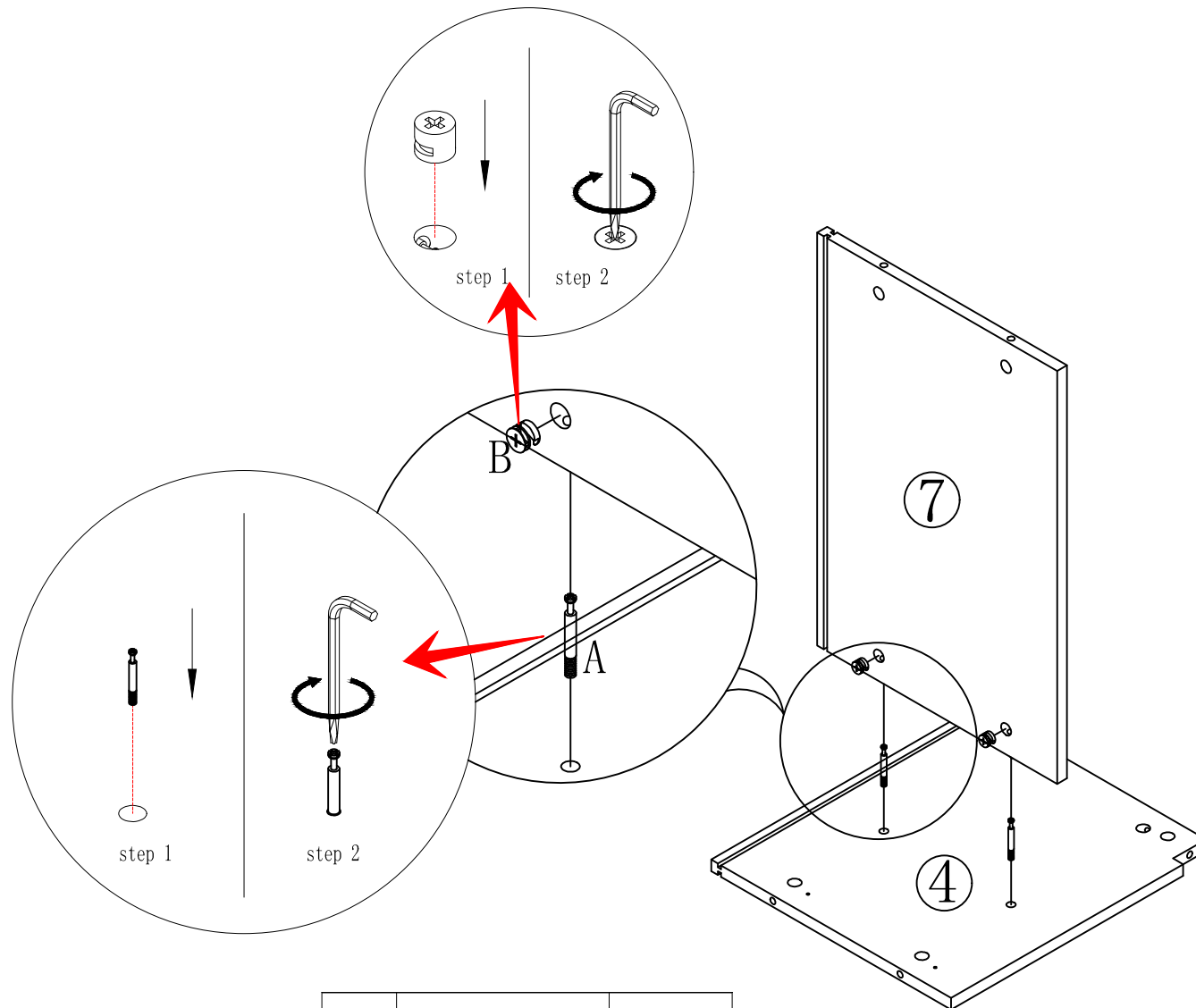

Finished.

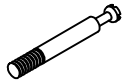
You should feel a click when the camlock is locked in place.
The joint is now secure.



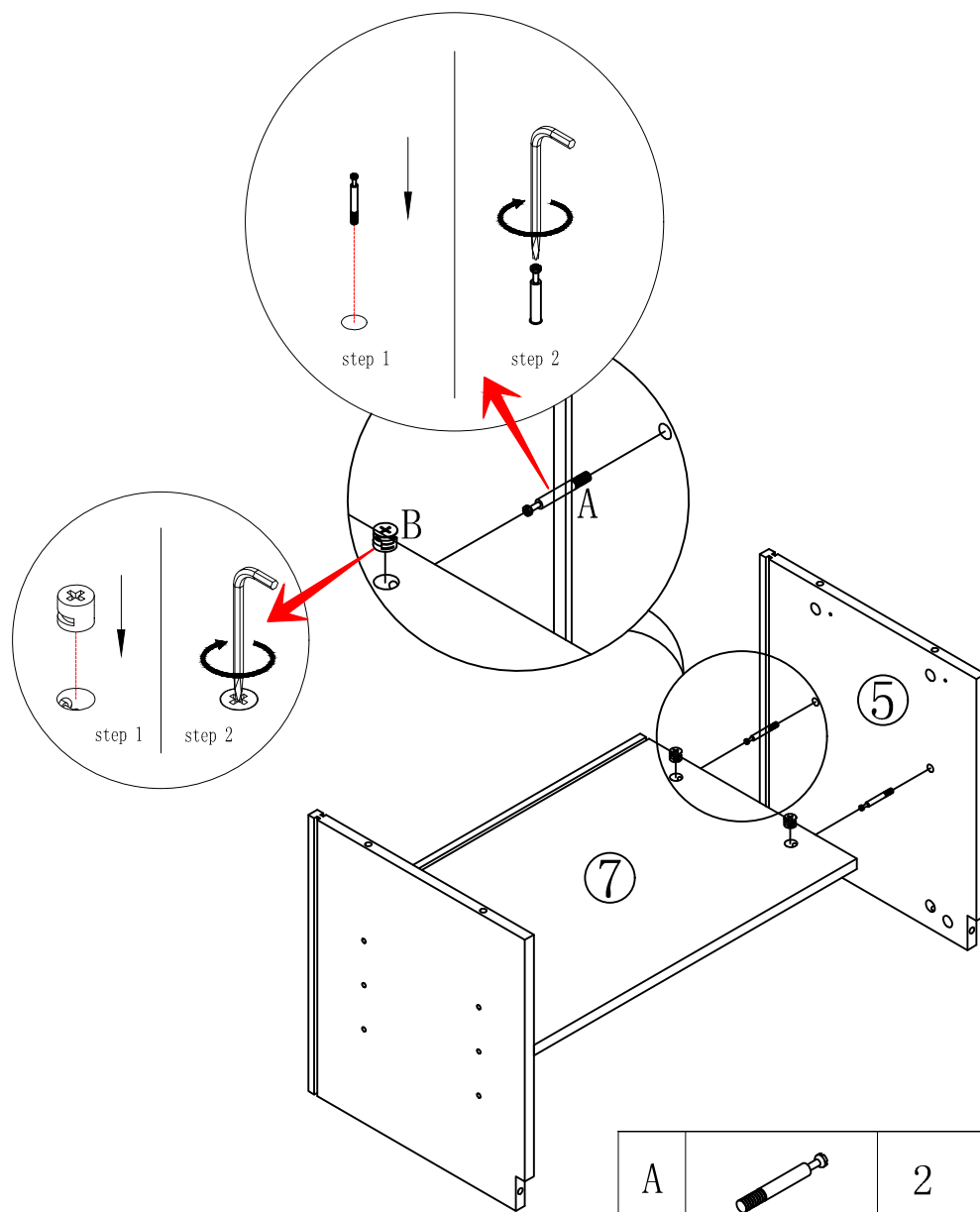

A		2
B		2



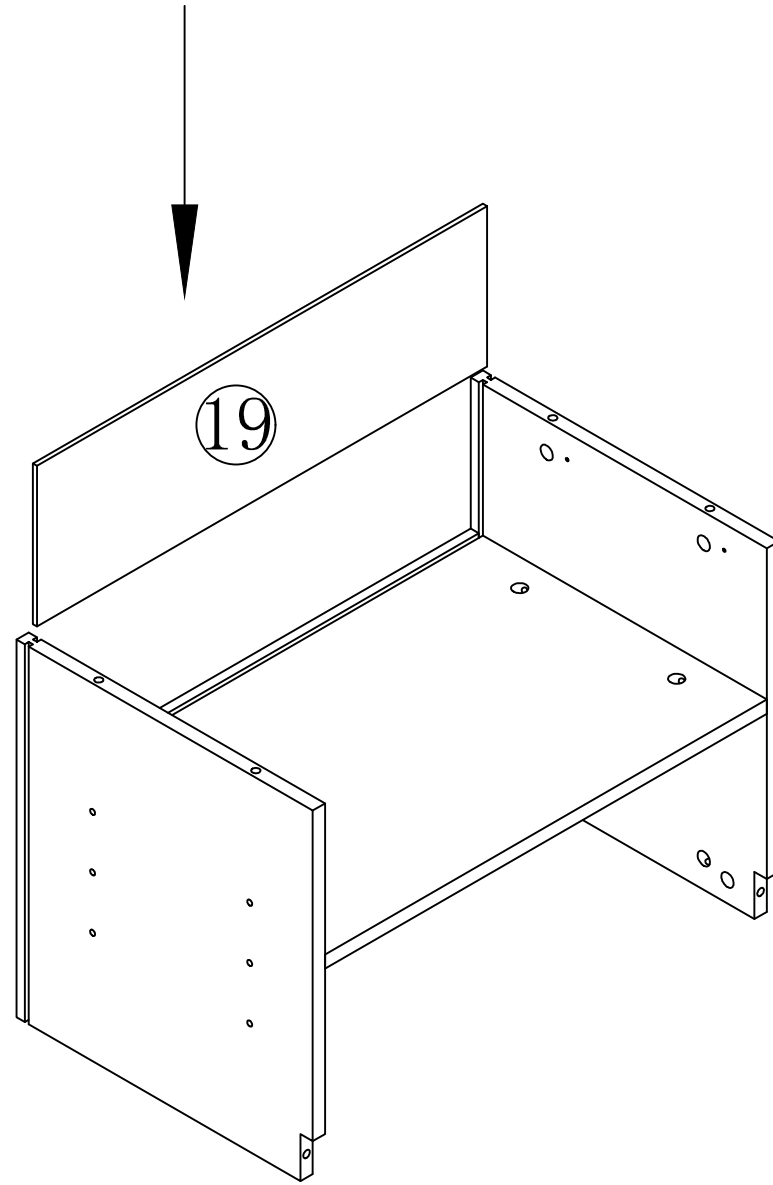

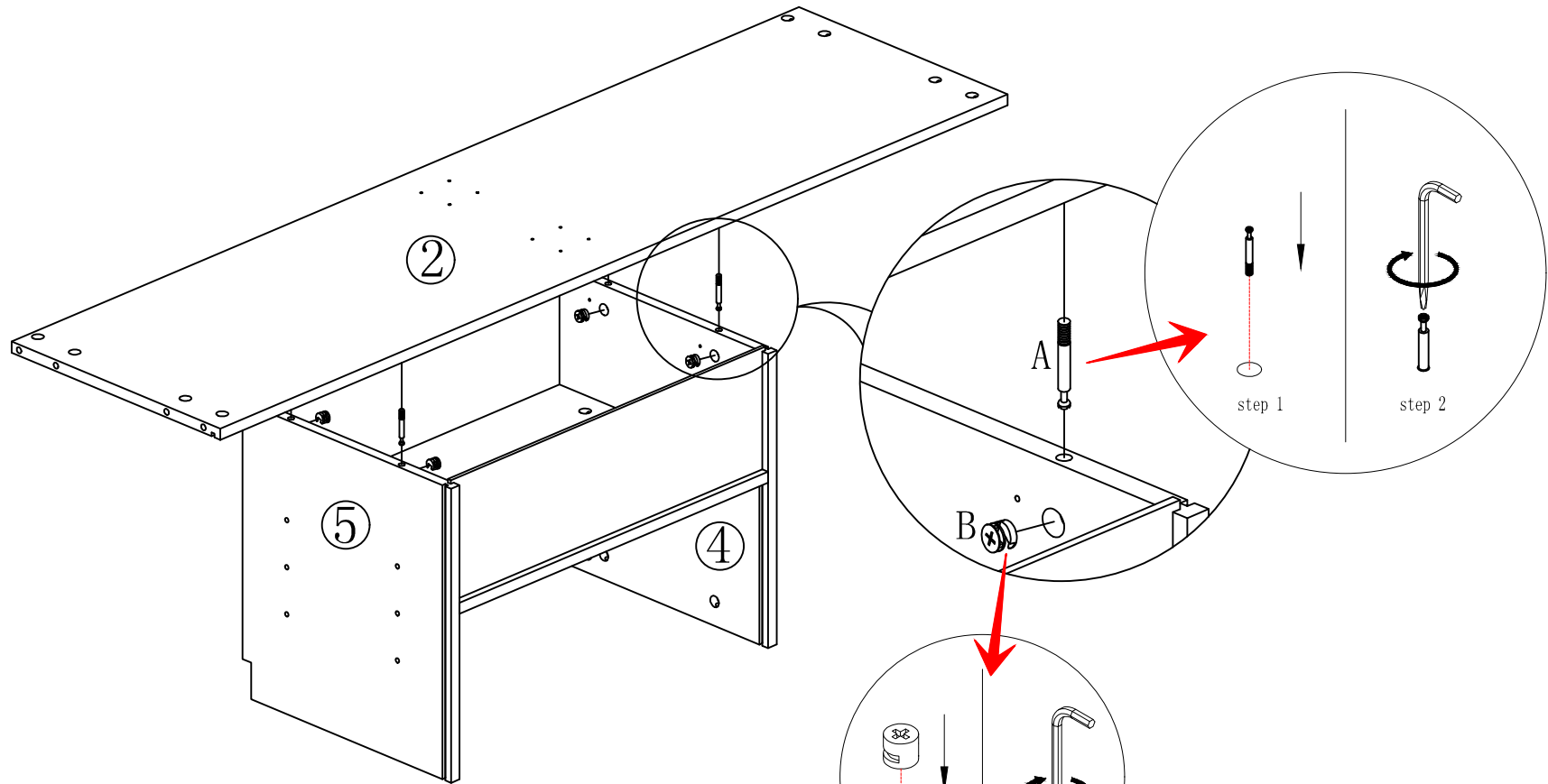
A		2
B		2

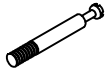



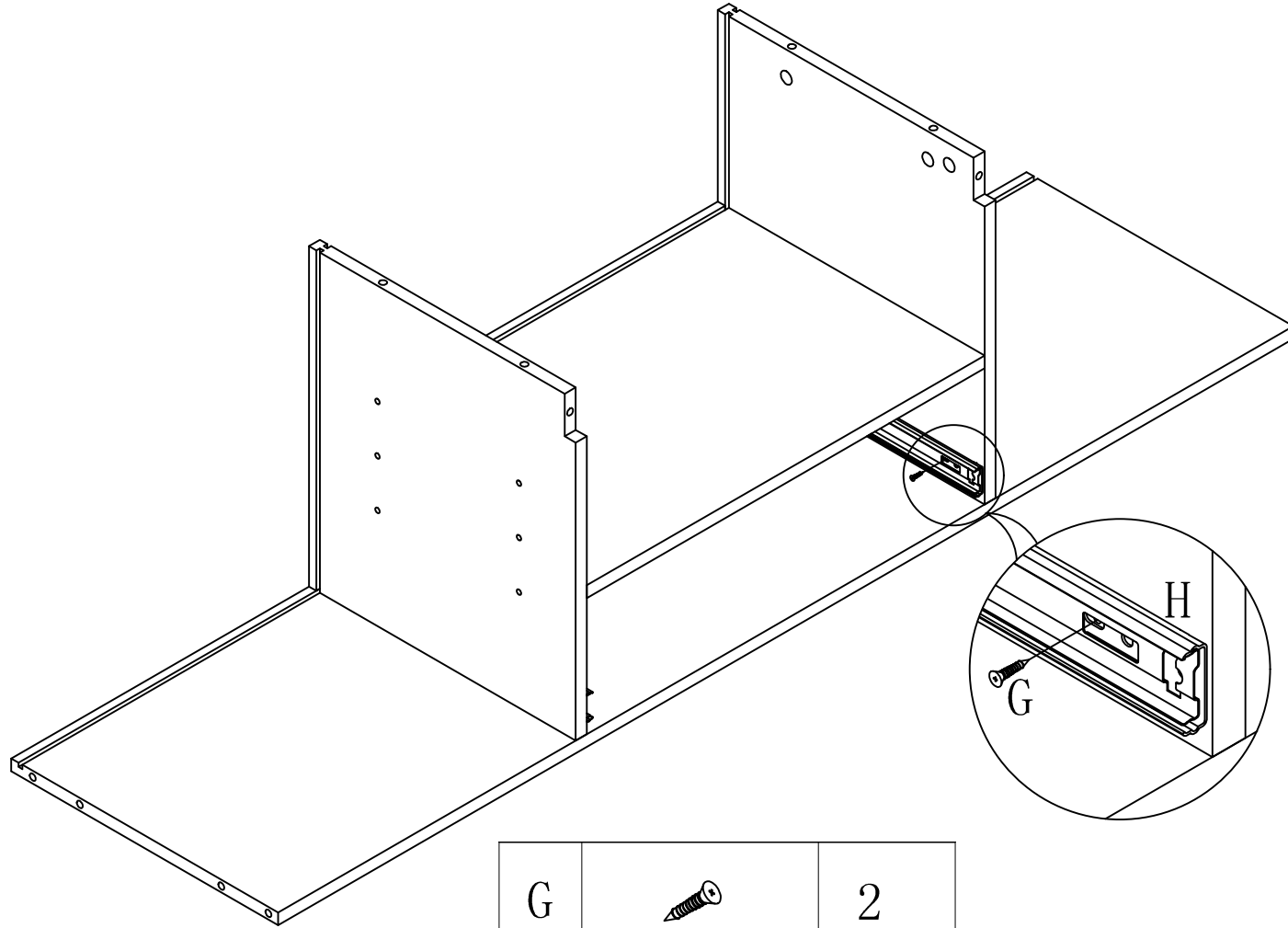

A		4
B		4



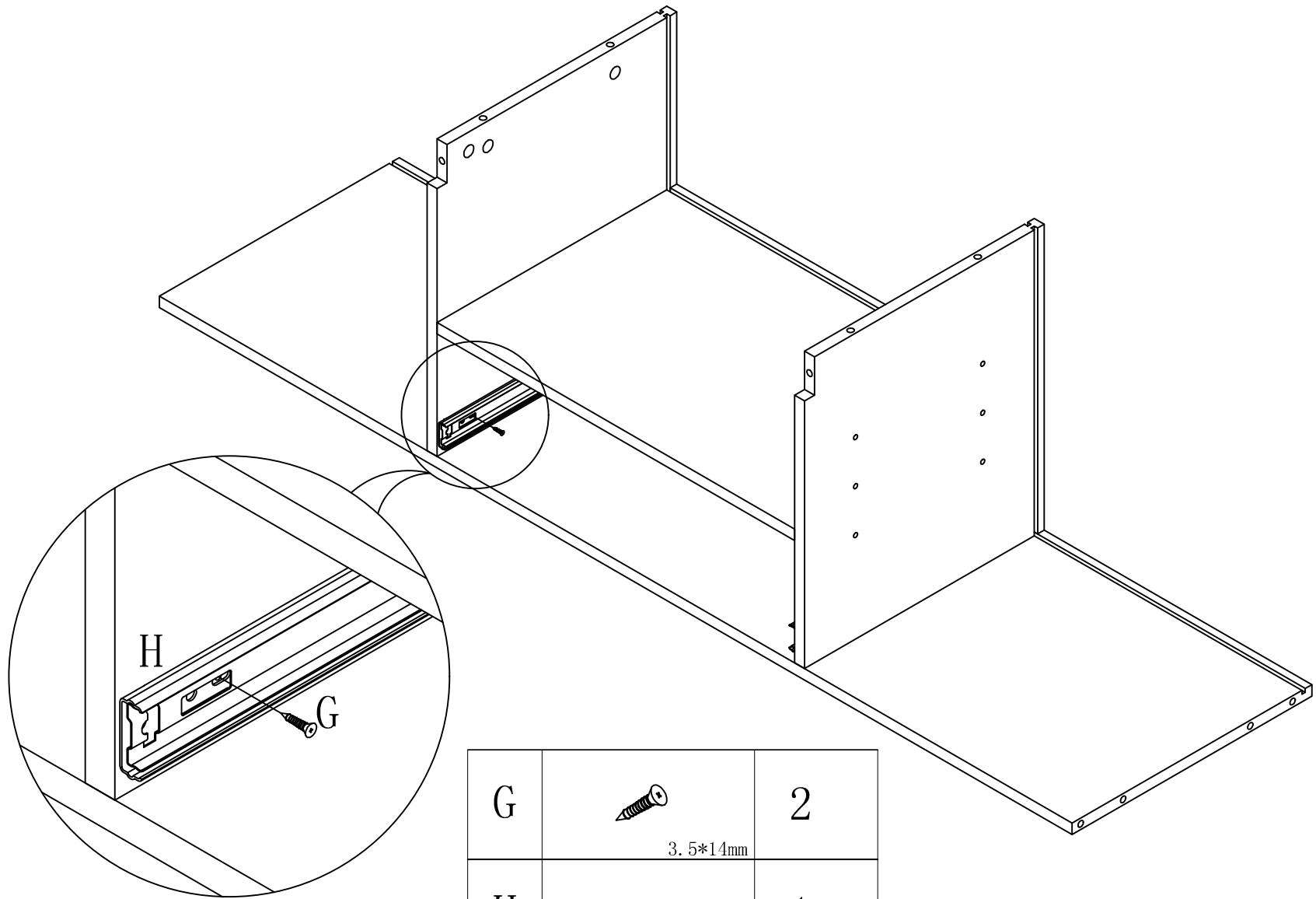

G	 3.5*14mm	2
H		1



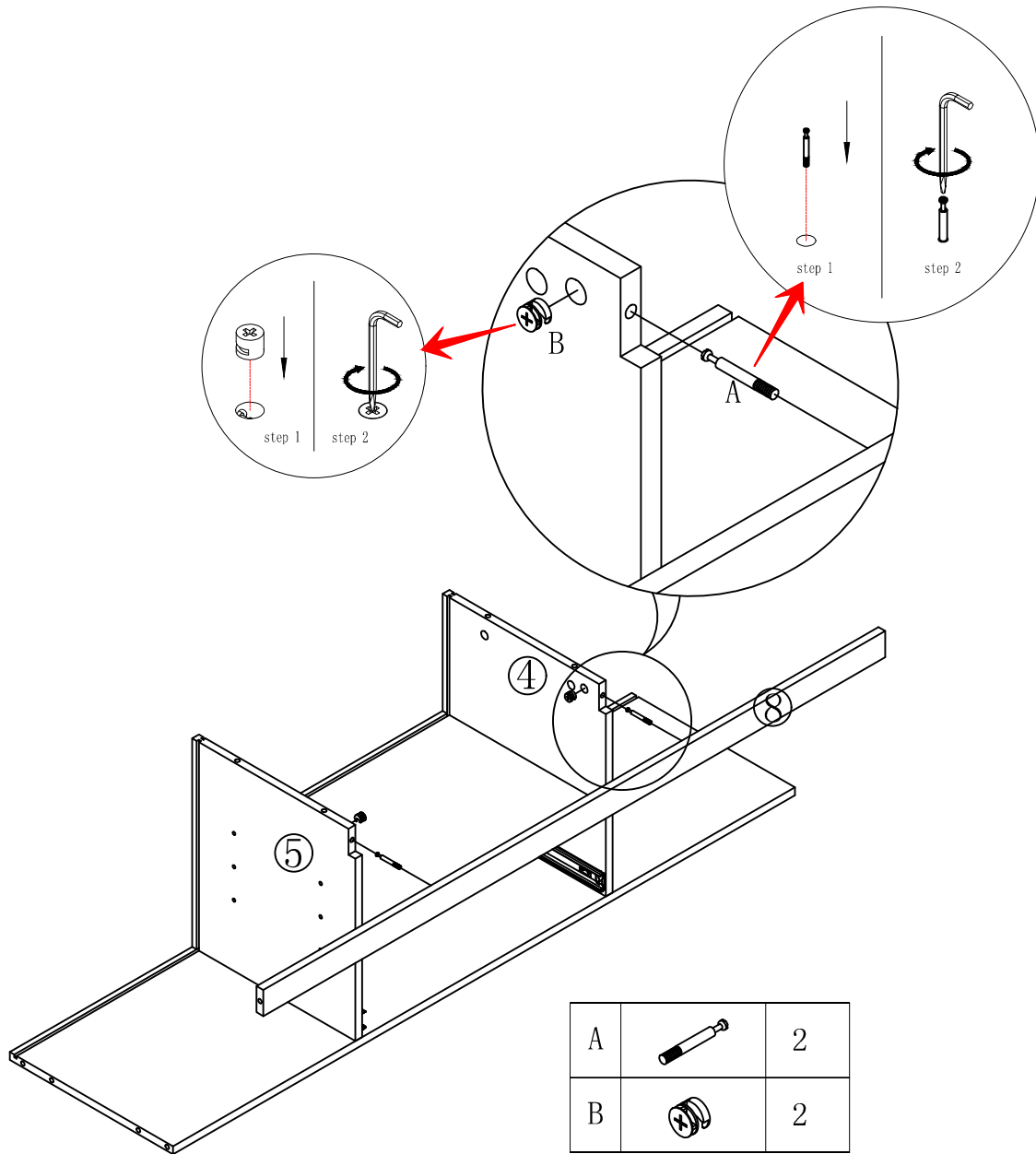

G	 3.5*14mm	2
H		1



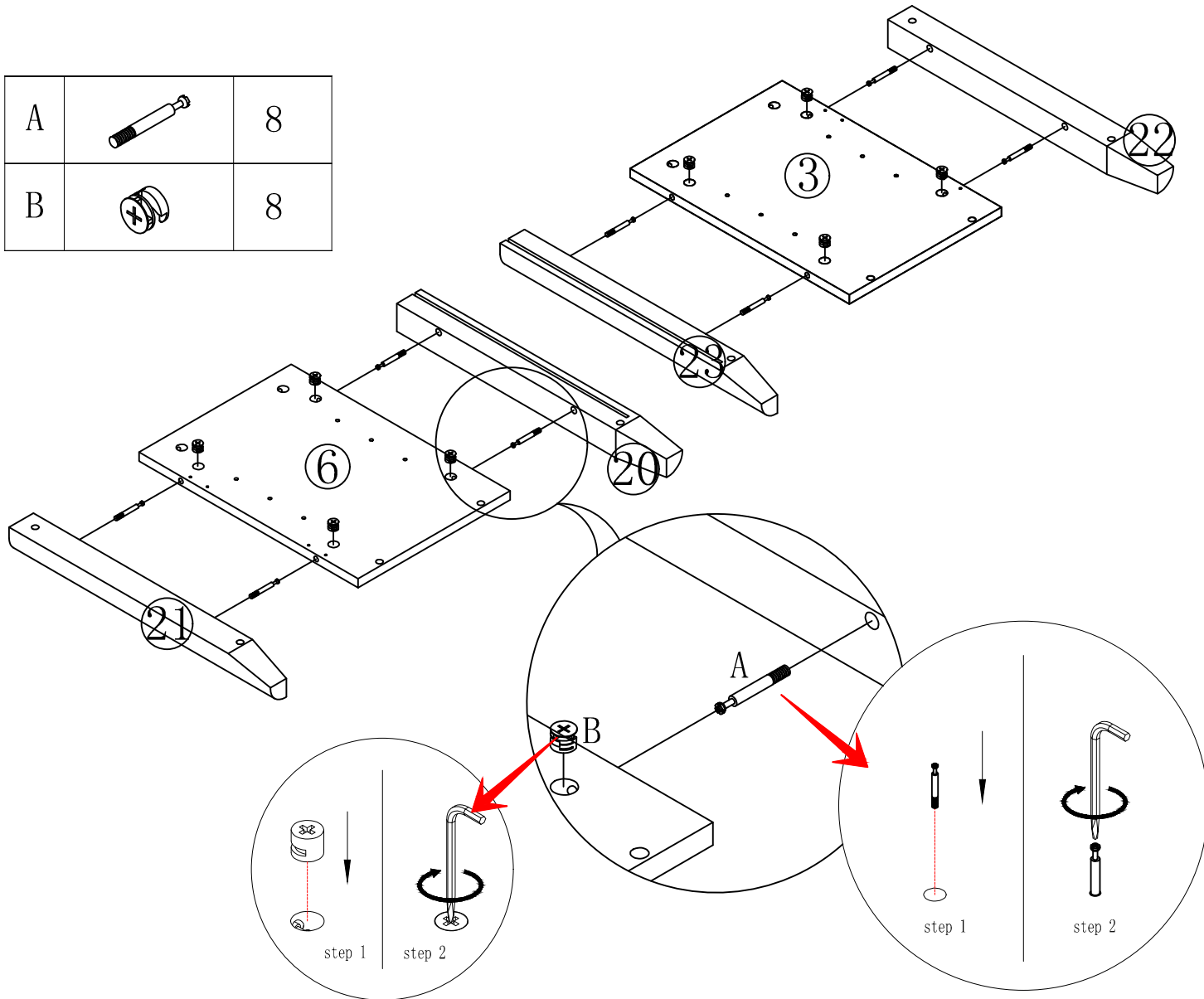

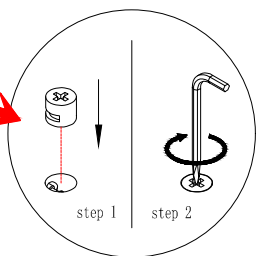
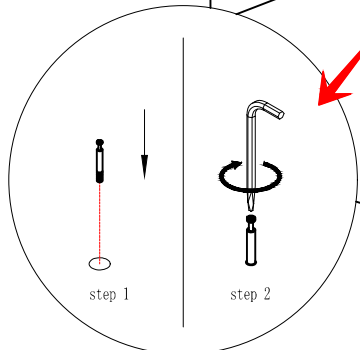
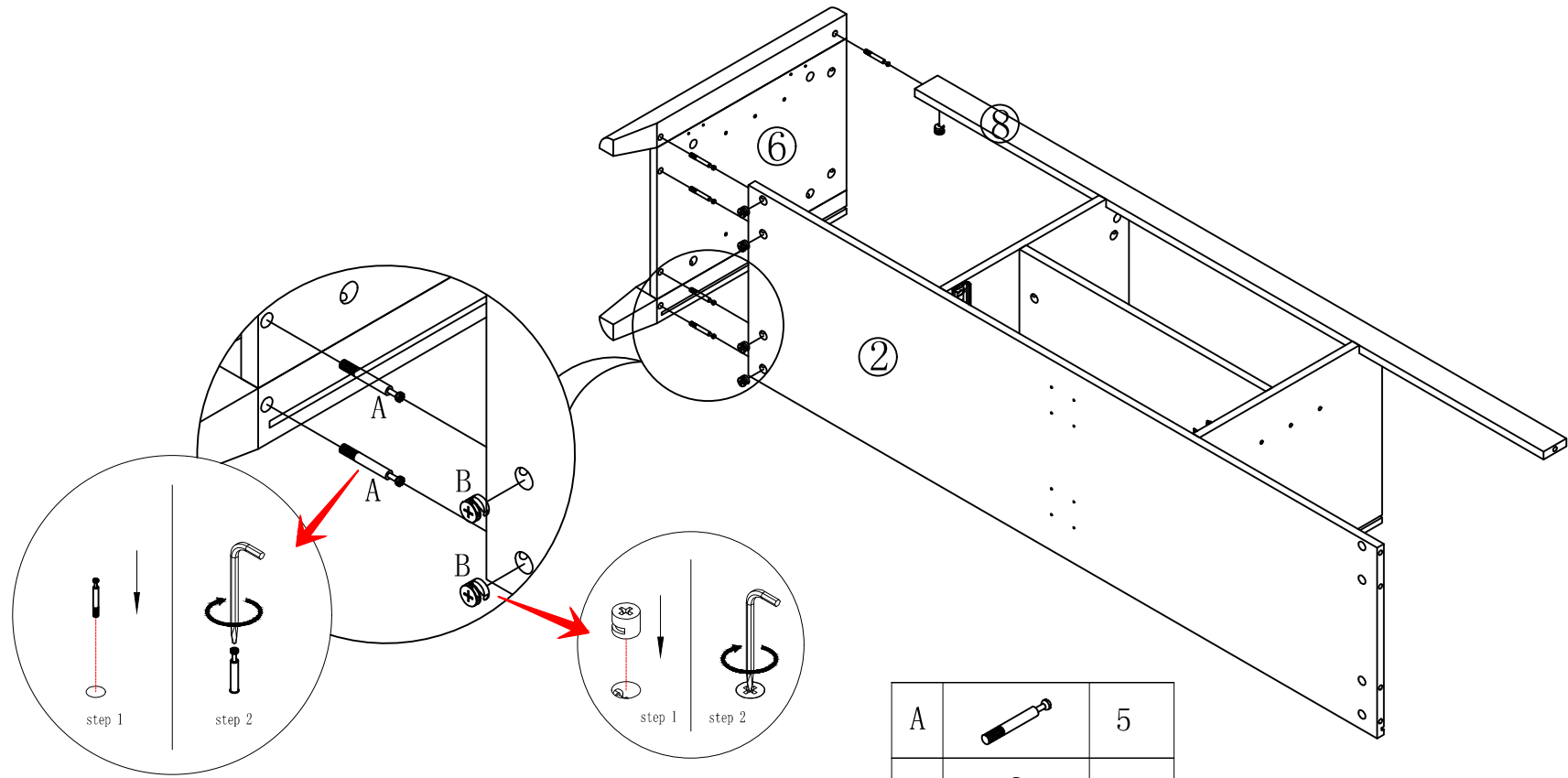
A		8
B		8



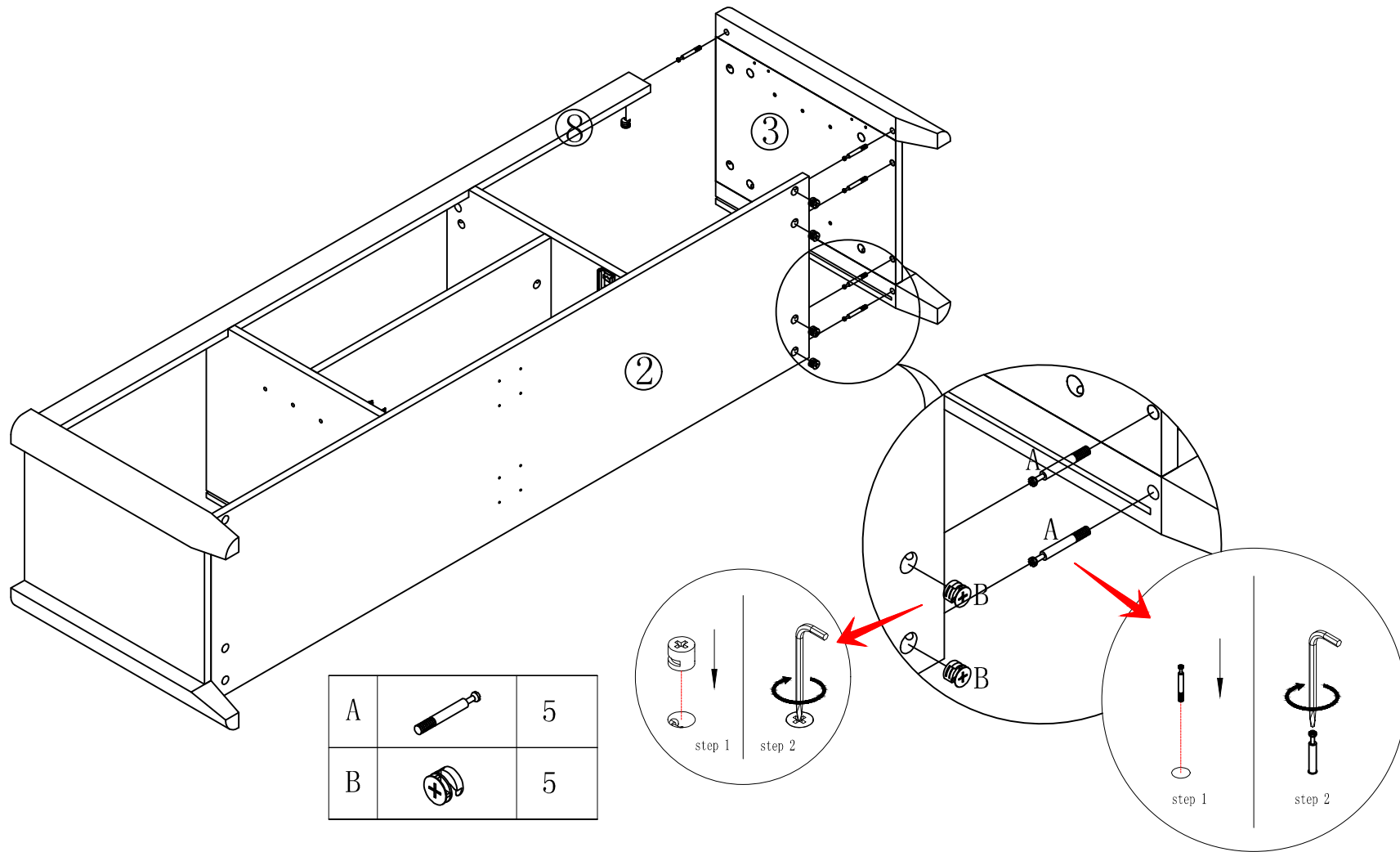

A		5
B		5



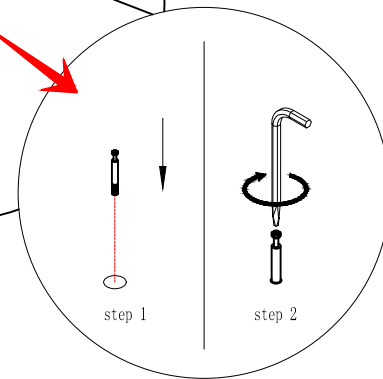
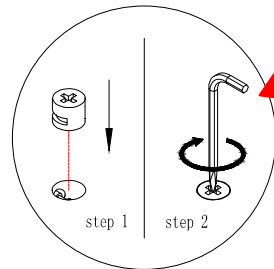

A		5
B		5

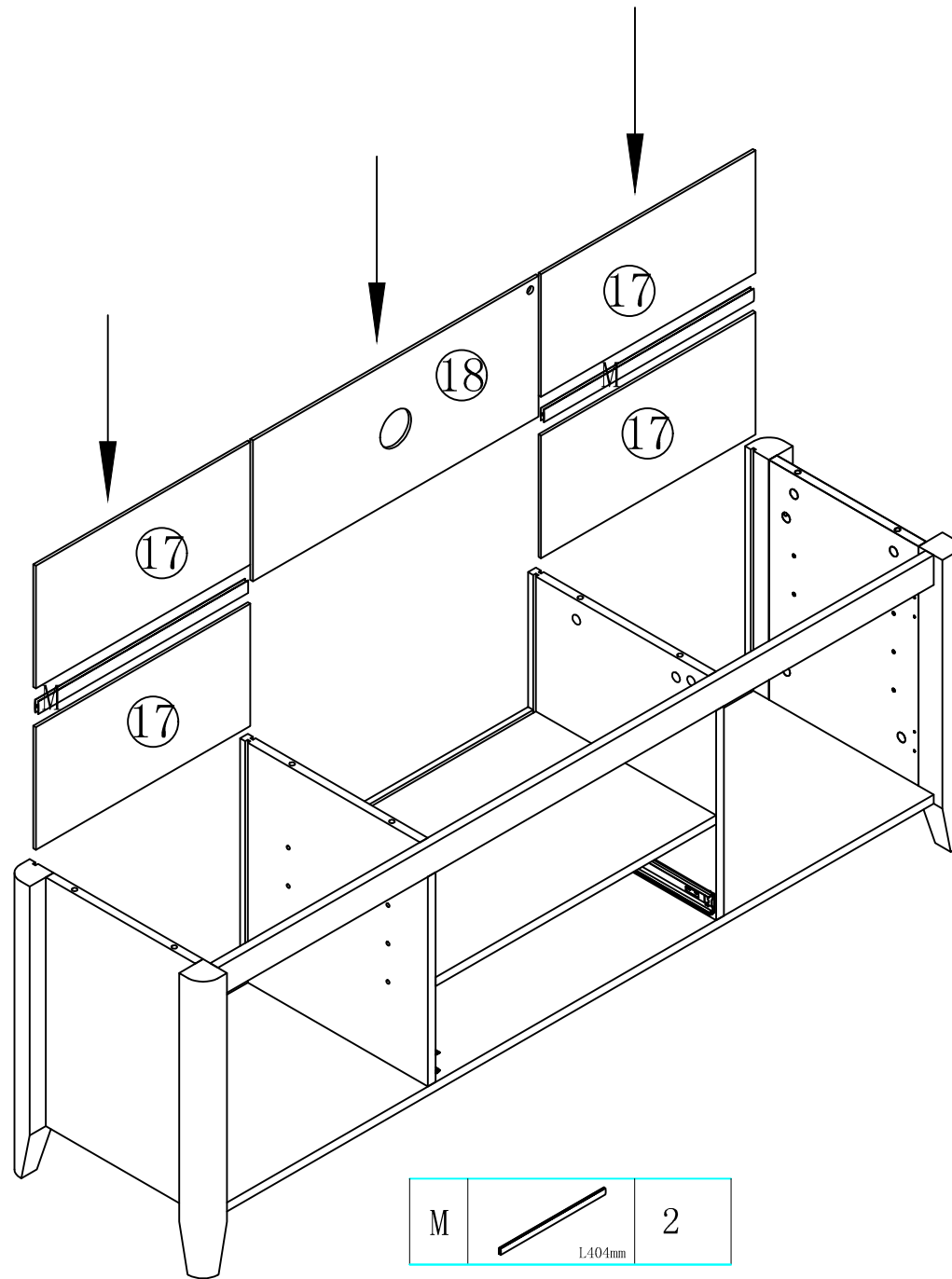

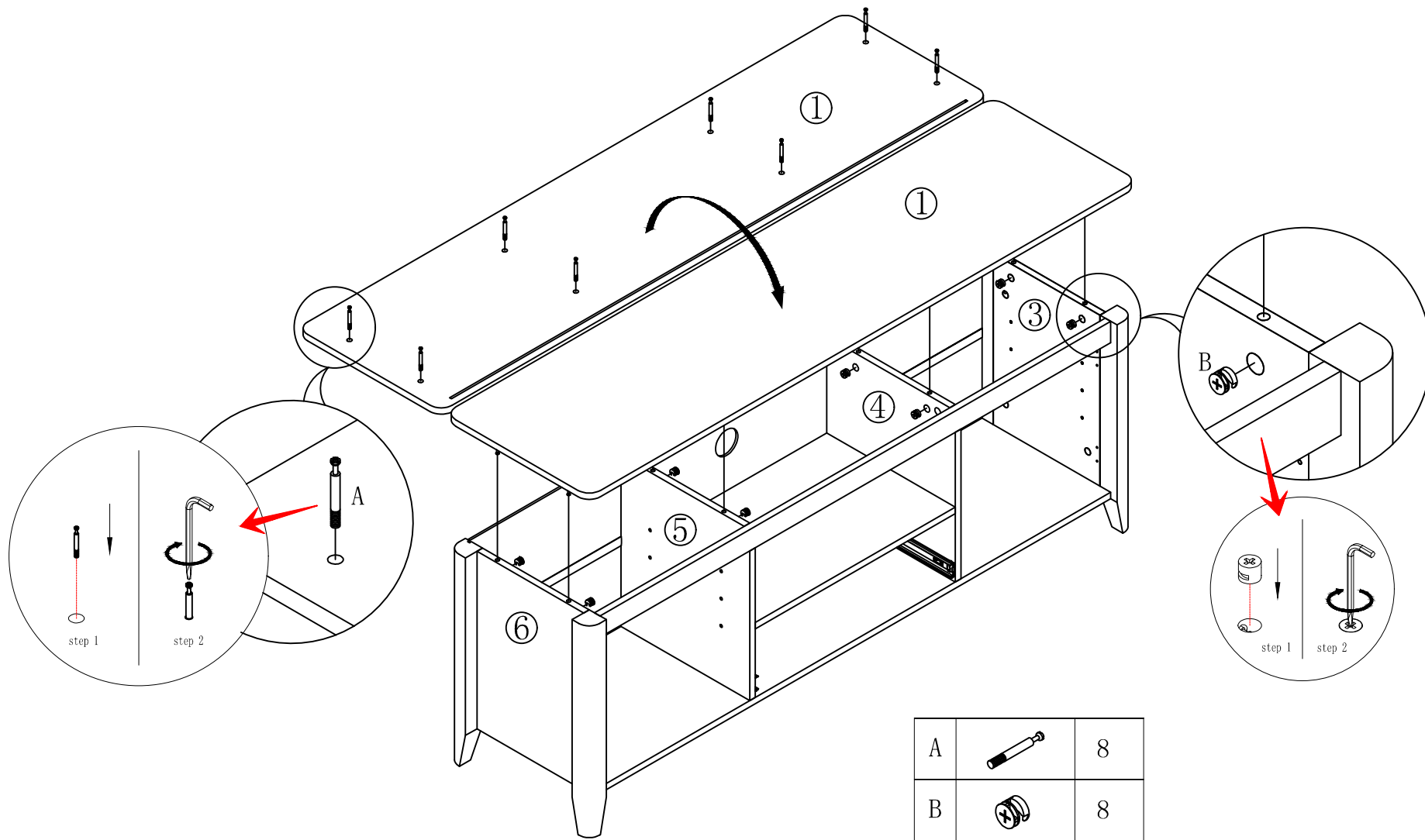

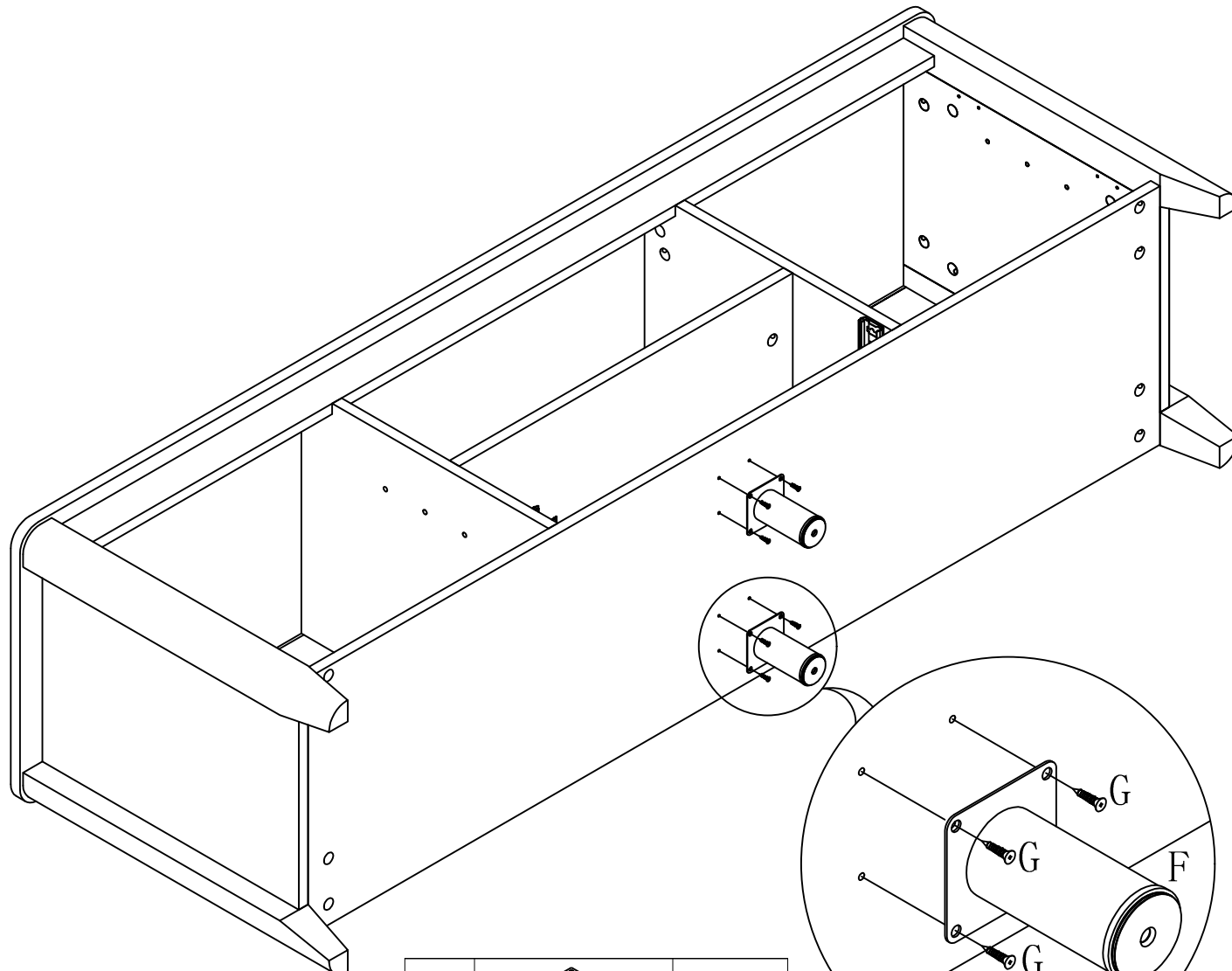





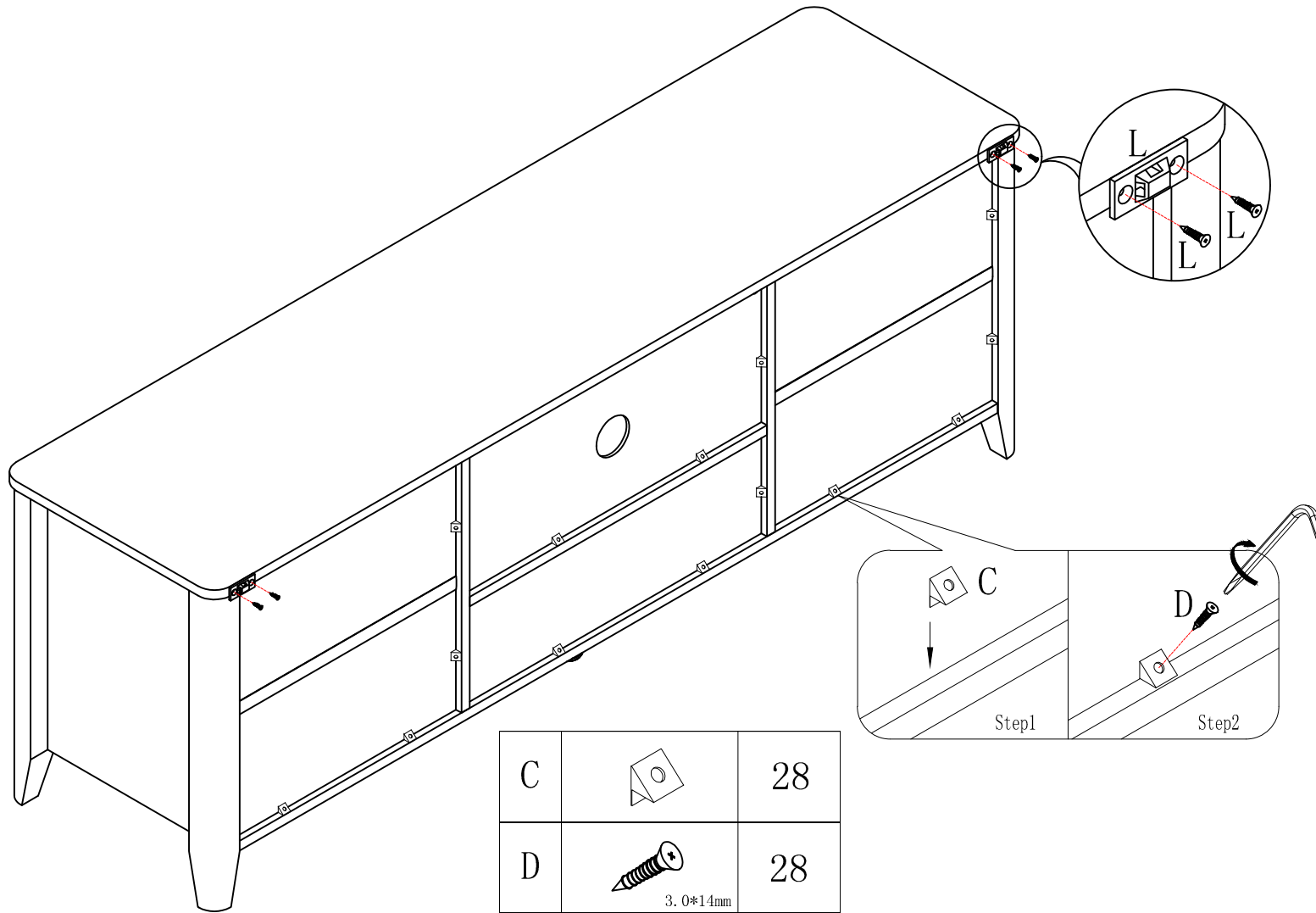

F	 38*85mm	2
G	 3.5*14mm	8

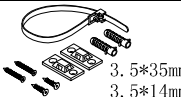

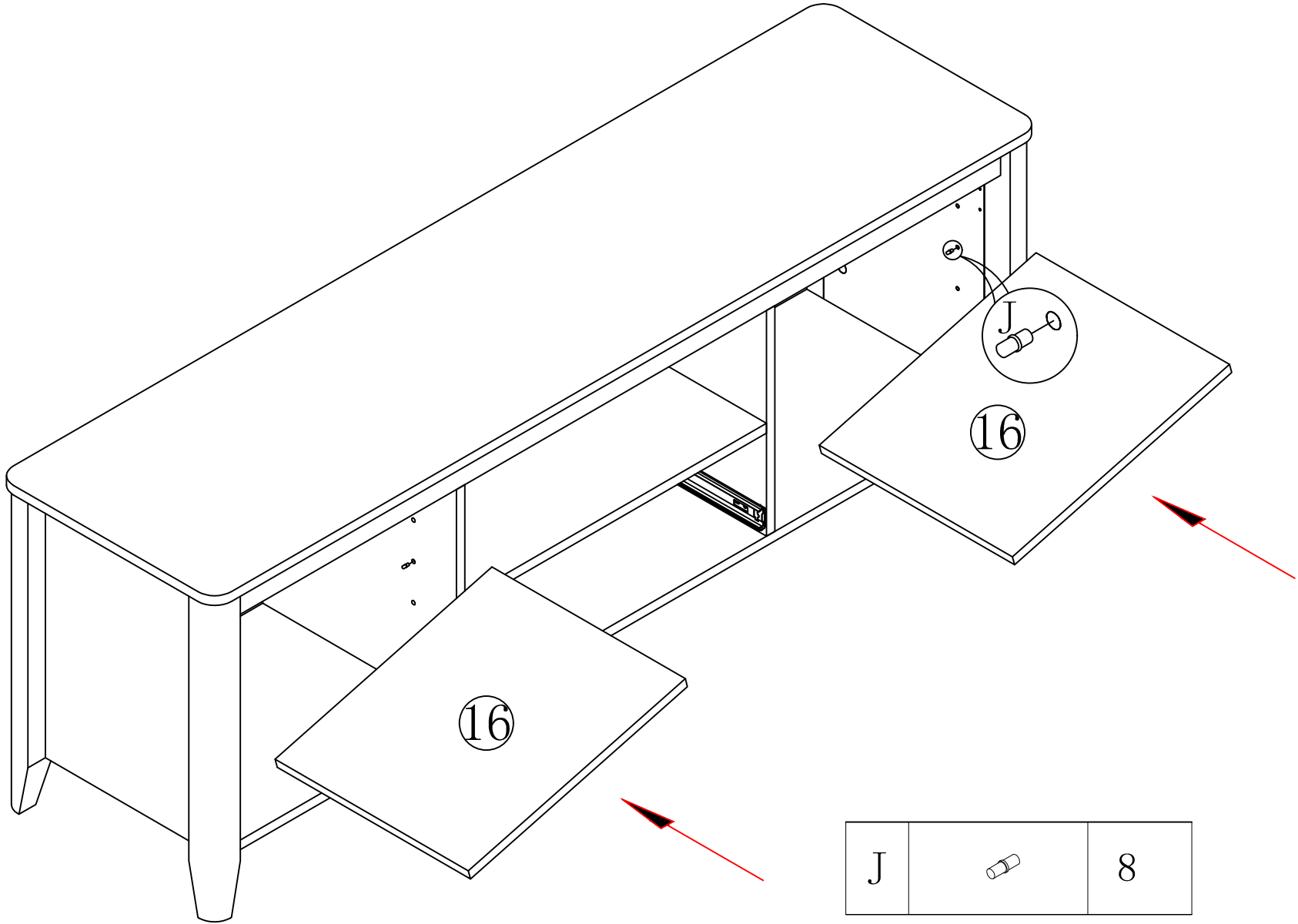
C		28
D	 3.0*14mm	28
L	 3.5*35mm 3.5*14mm	2



J		8
---	---	---

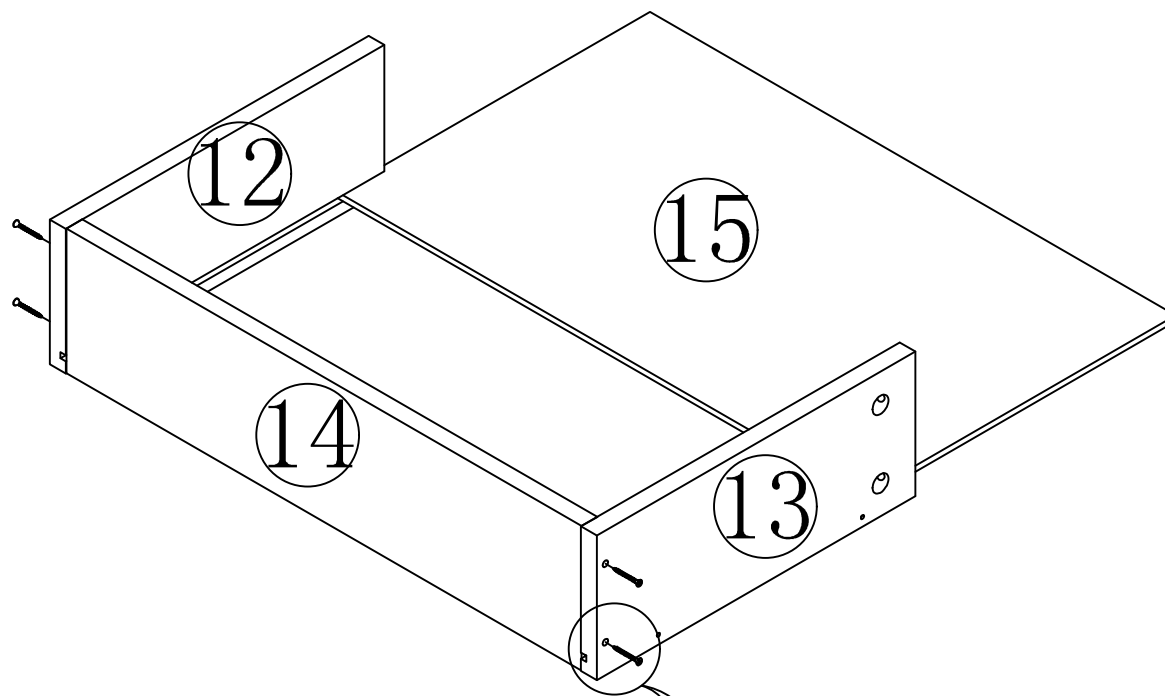

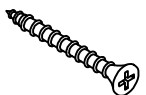

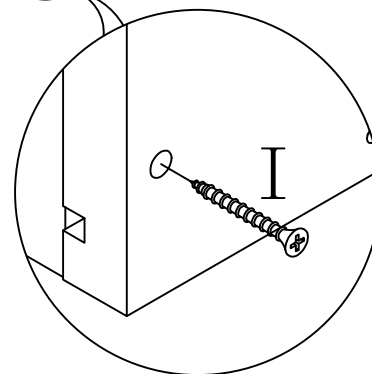
I		4
---	---	---

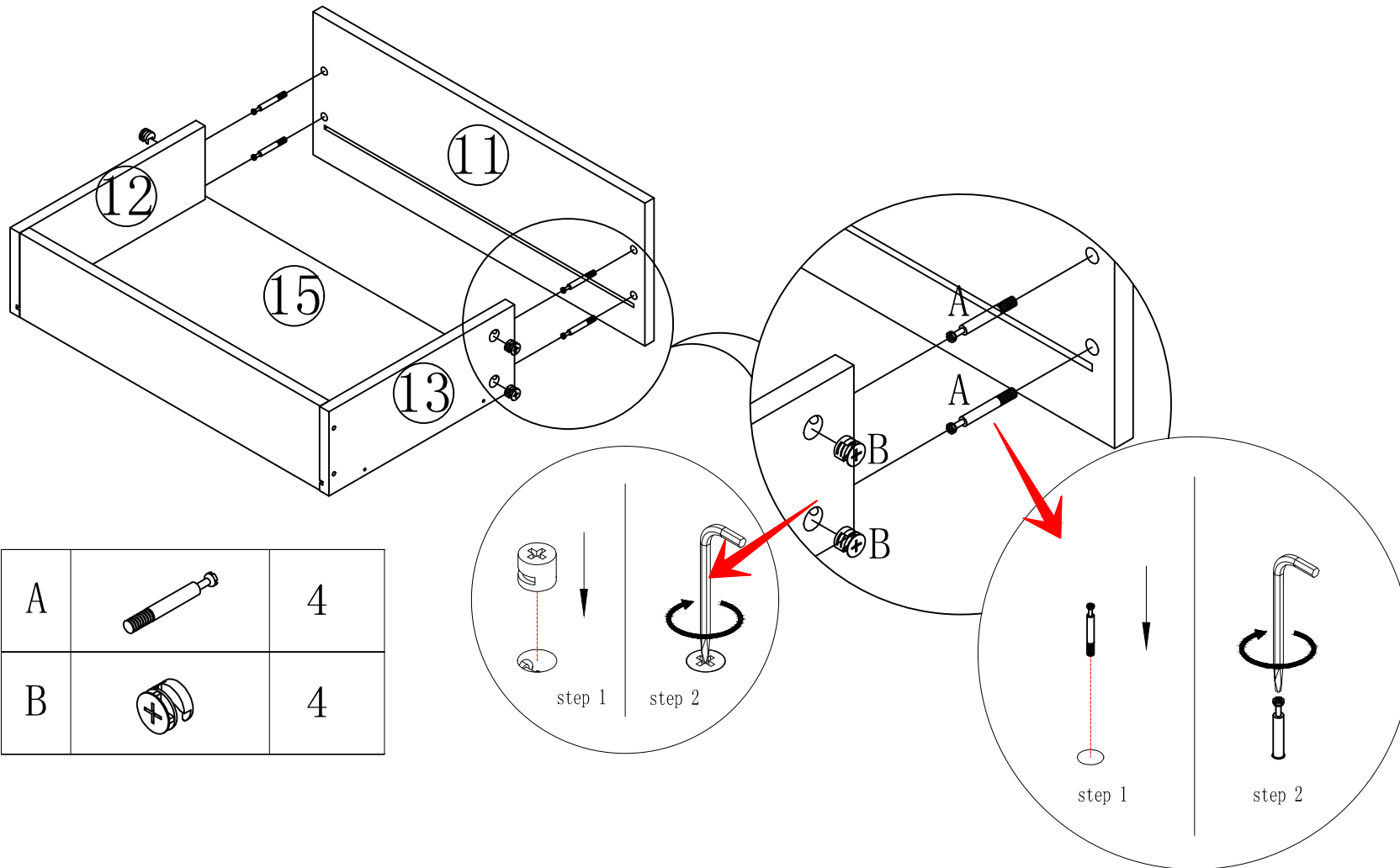

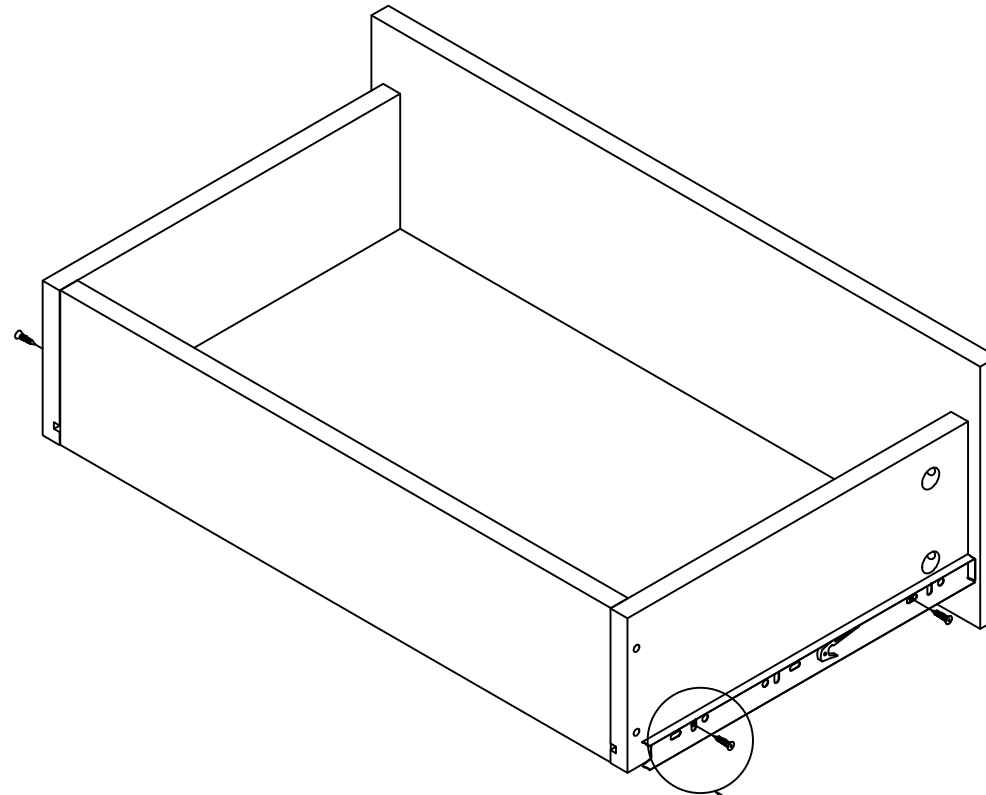



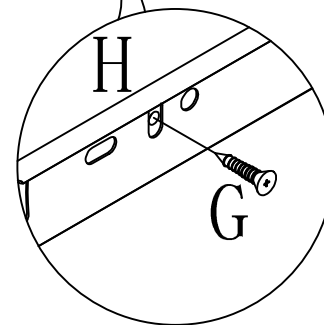

G	 3.5*14mm	4
H		2

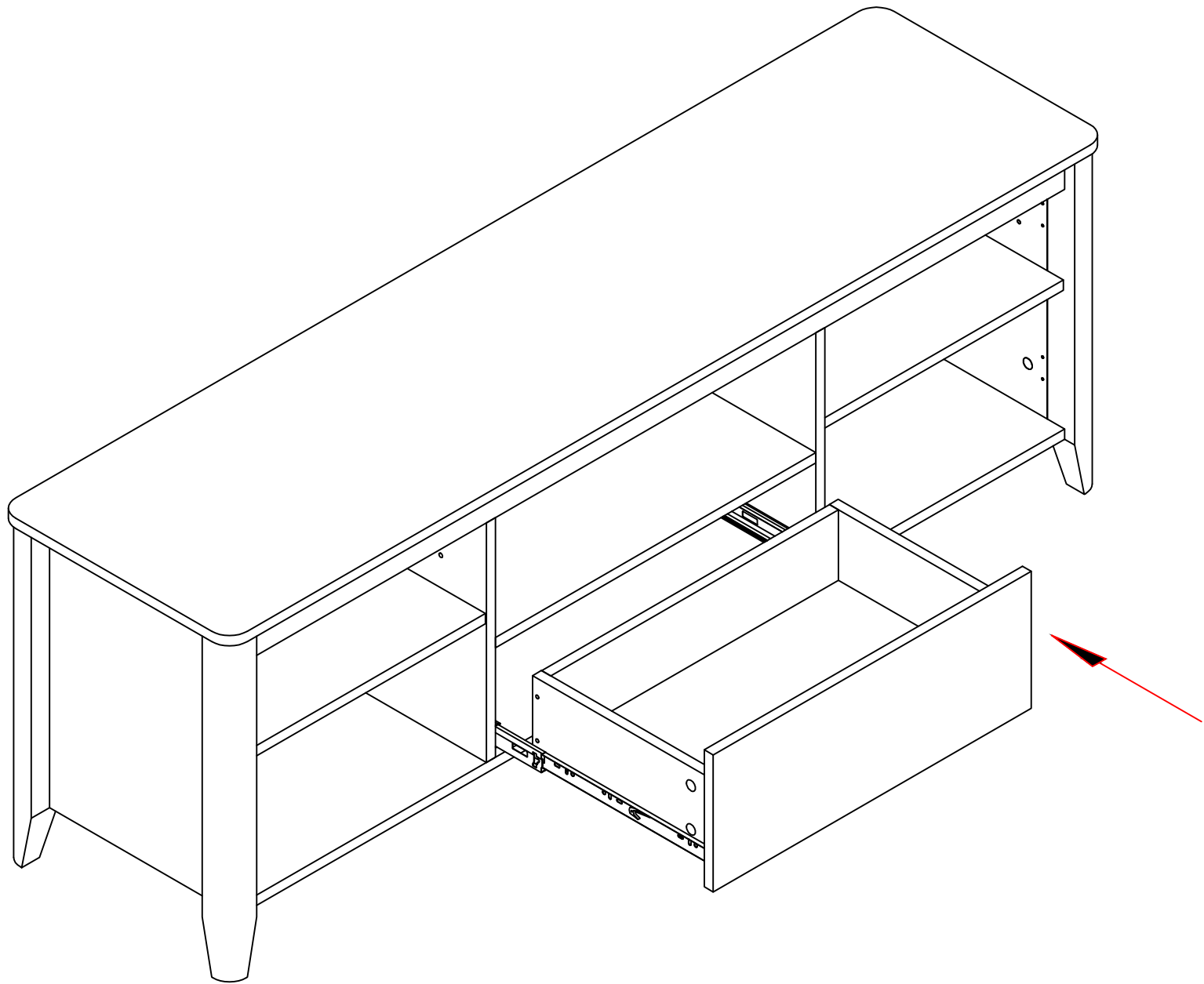

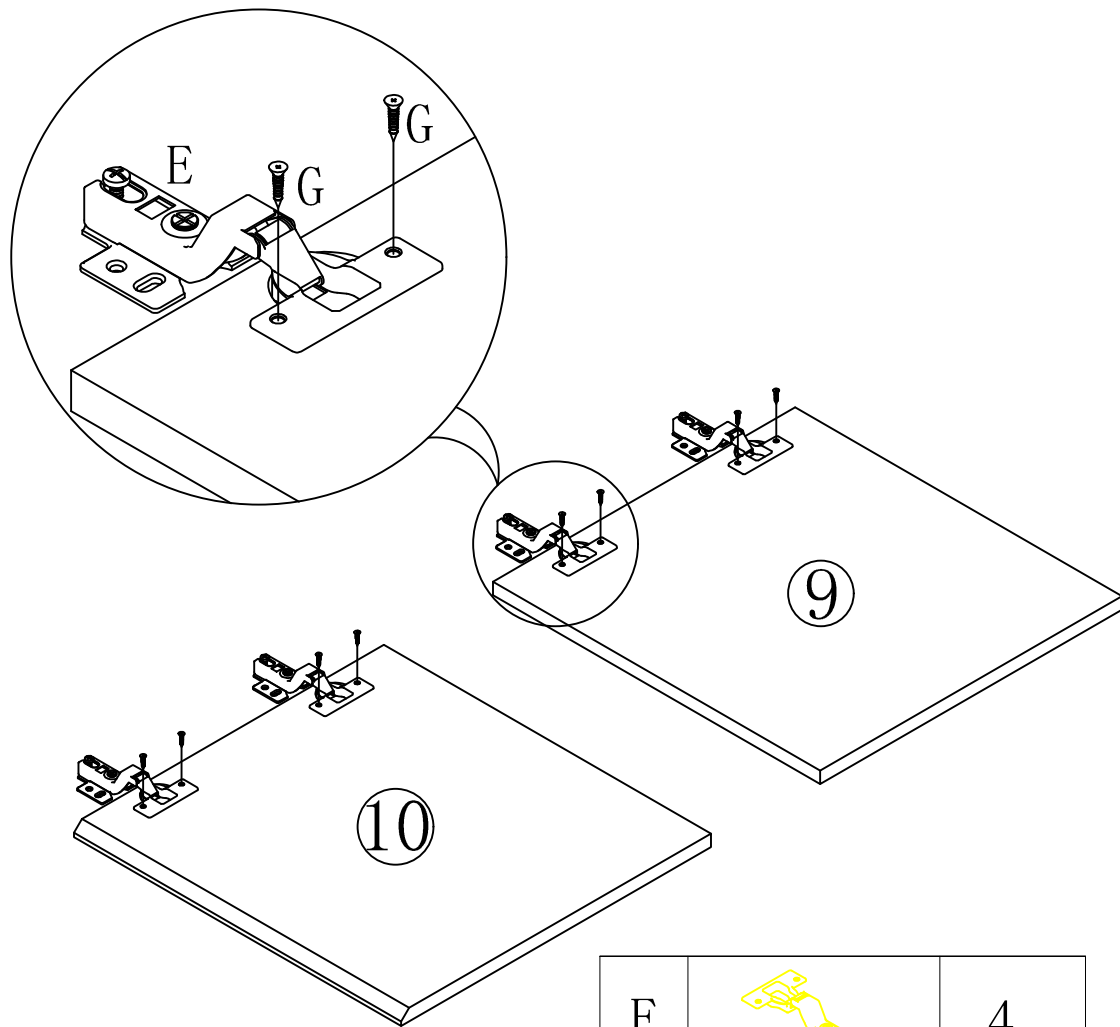

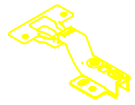

E		4
G	 3.5*14mm	8

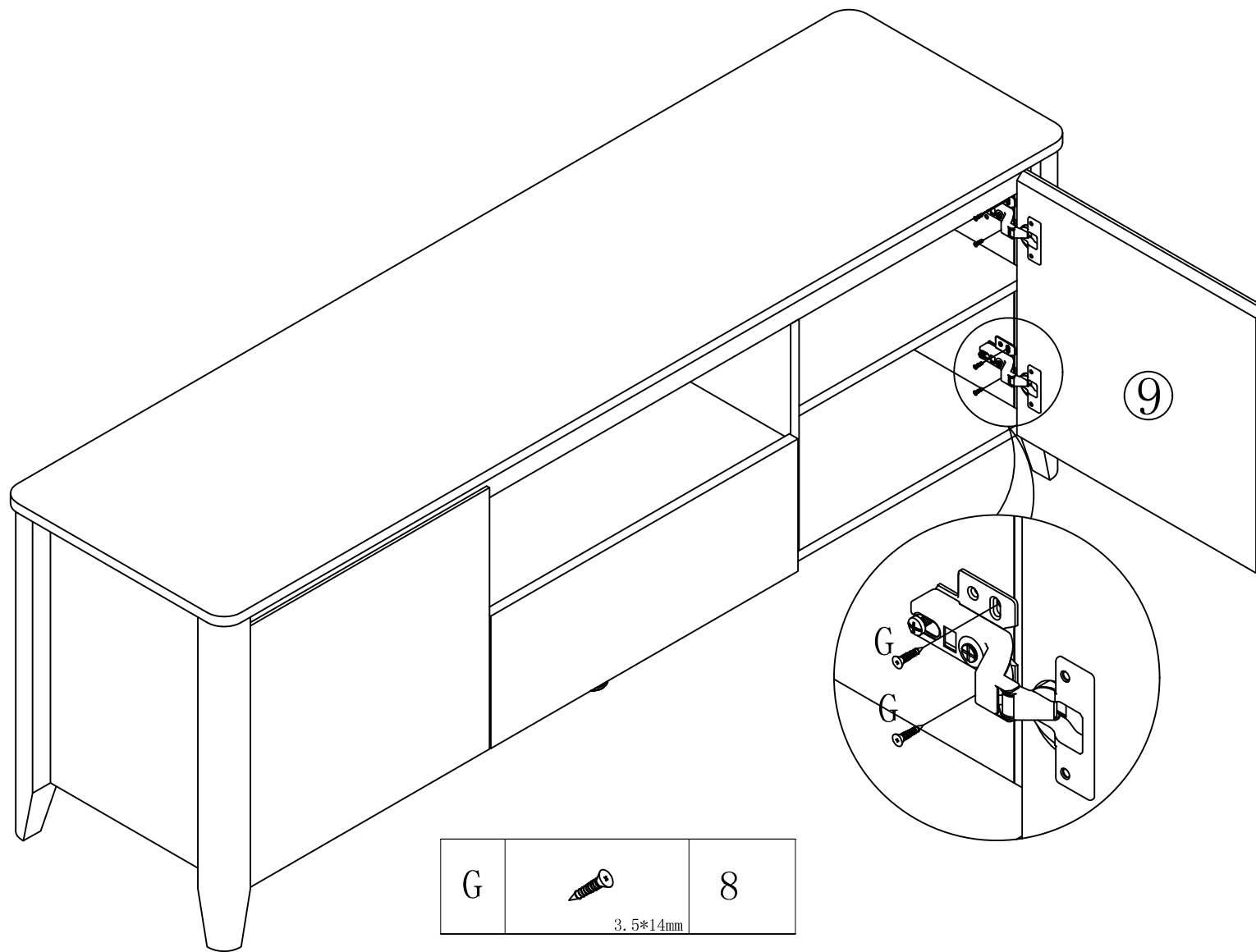

G	 3.5*14mm	8
---	---	---

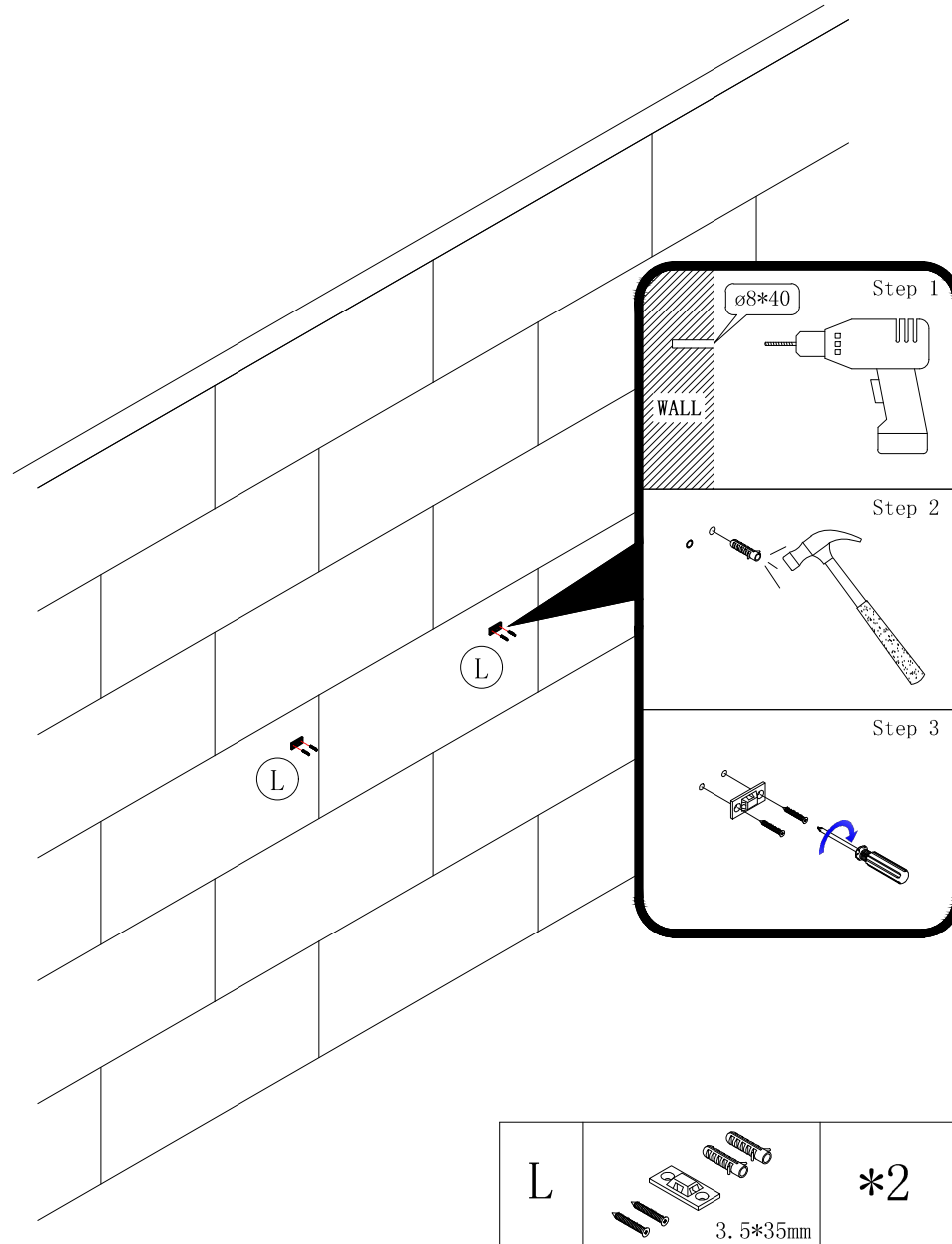

Step 1

ø8*40

WALL

Step 2

Step 3

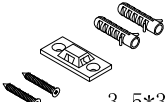
L	 <p>3.5*35mm</p>	*2
---	---	----

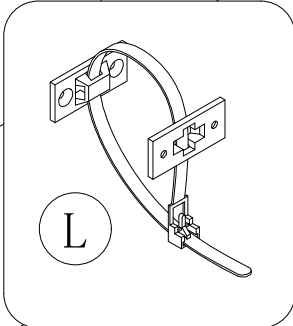
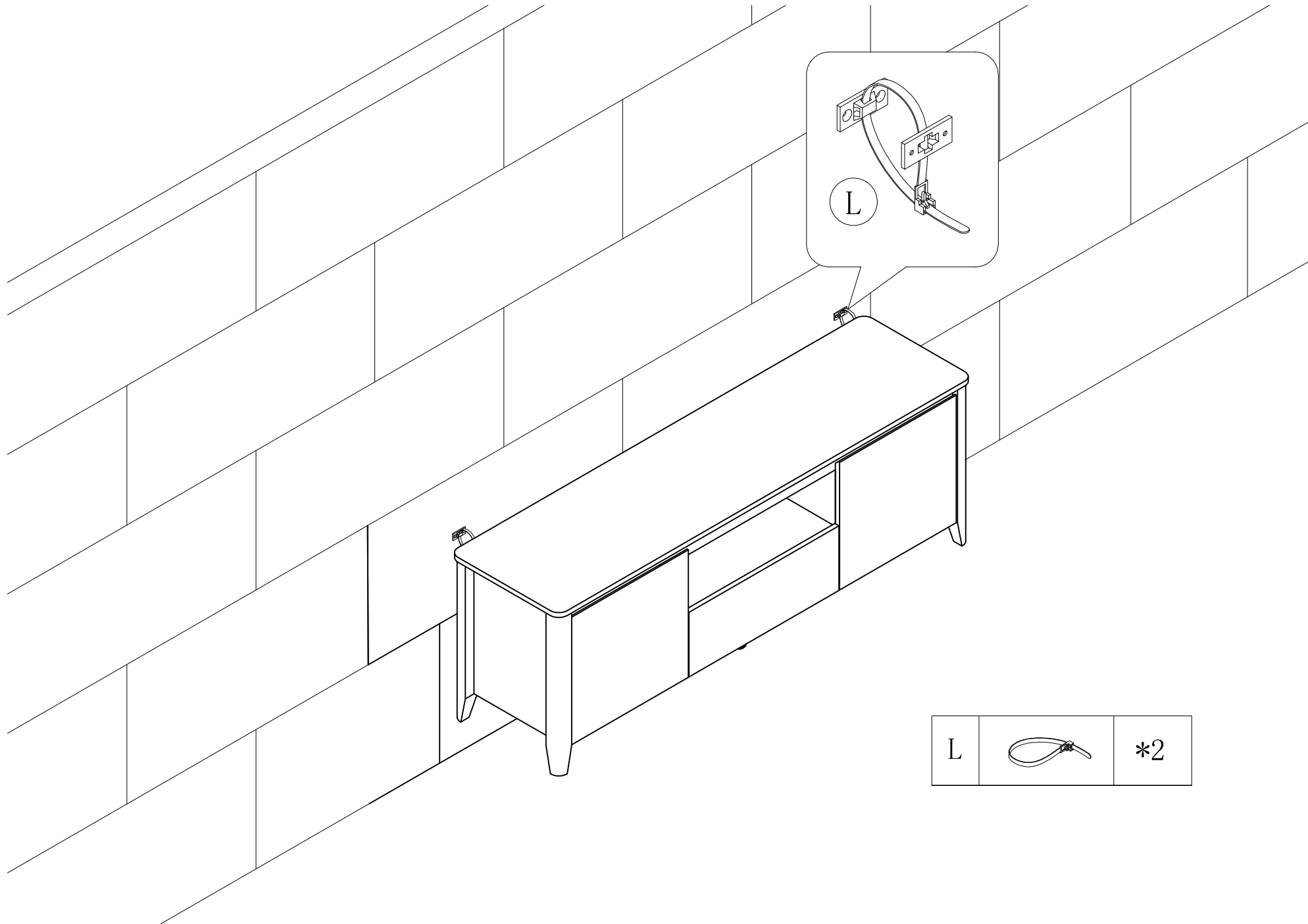

L		*2
---	--	----