

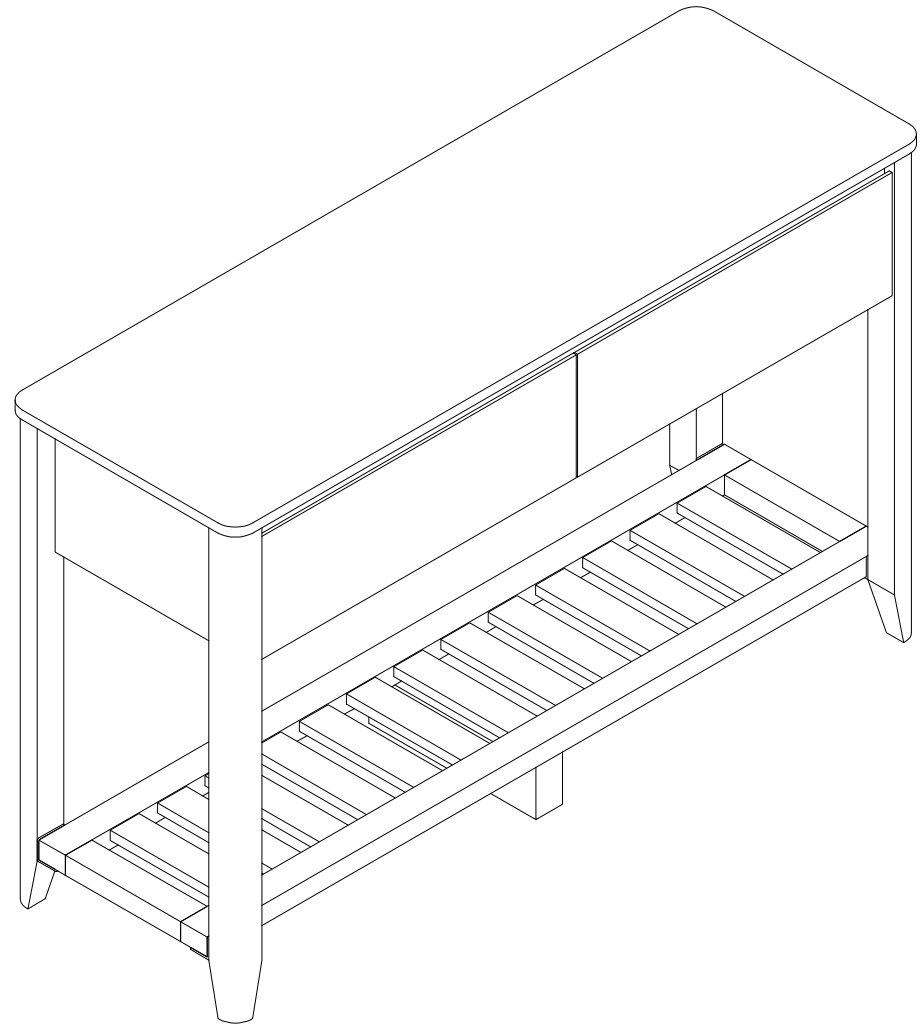

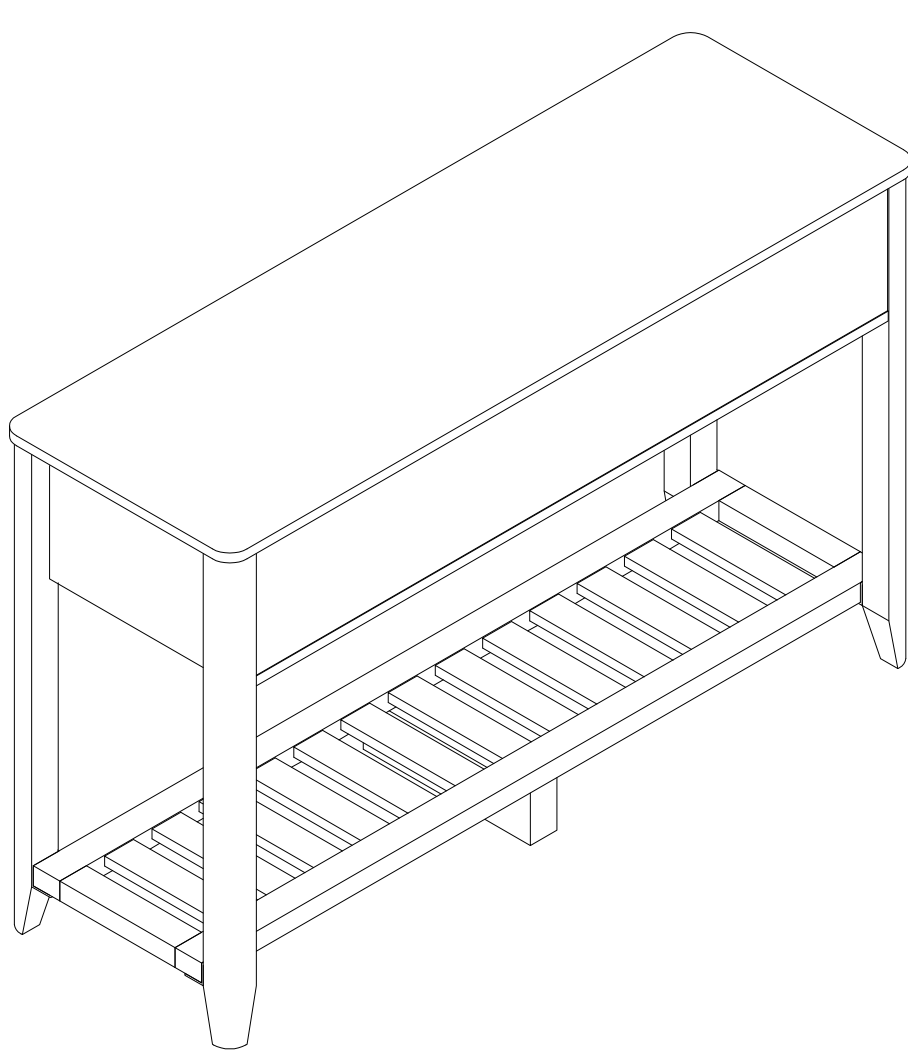



















User Manual
ASSEMBLY INSTRUCTION
CD-099











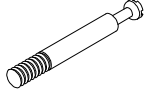

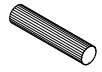
Parts List

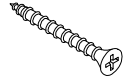
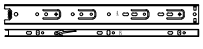
NO.	Drawing	Dimension	QTY
1		1200*400*15mm	1
2		1098*372*15mm	1
3		206*298*15mm	1
4		190*356*15mm	1
5		206*298*15mm	1
6		1098*190*15mm	1
7		1190*46*30mm	2
8		200*46*30mm	2
9		200*50*15mm	13
10		735*46*46mm	1

NO.	Drawing	Dimension	QTY
11		735*46*46mm	1
12		735*46*46mm	1
13		735*46*46mm	1
14		546*185*15mm	1
15		546*185*15mm	1
16		350*118*15mm	2
17		350*118*15mm	2
18		486*118*15mm	2
19		496*344*4mm	2
20		290*80*46mm	1
21		1098*40*20mm	1

Hardware Fitting

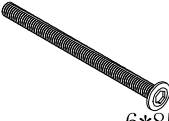
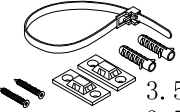
NO.	Drawing	QTY
A		50
B		50
C		60
D	 3.5*14mm	20
E	 3.5*35mm	8
F		4

NO.	Drawing	QTY
G	 6*12mm	8
H	 6*12mm	10
I		4
J	 6*50mm	2
K	 6*85mm	2
L	 3.5*35mm 3.5*14mm	2
M		1

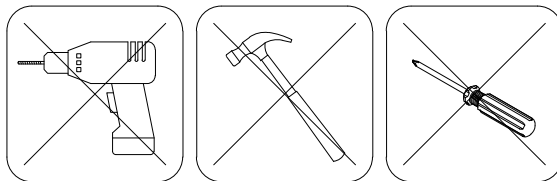

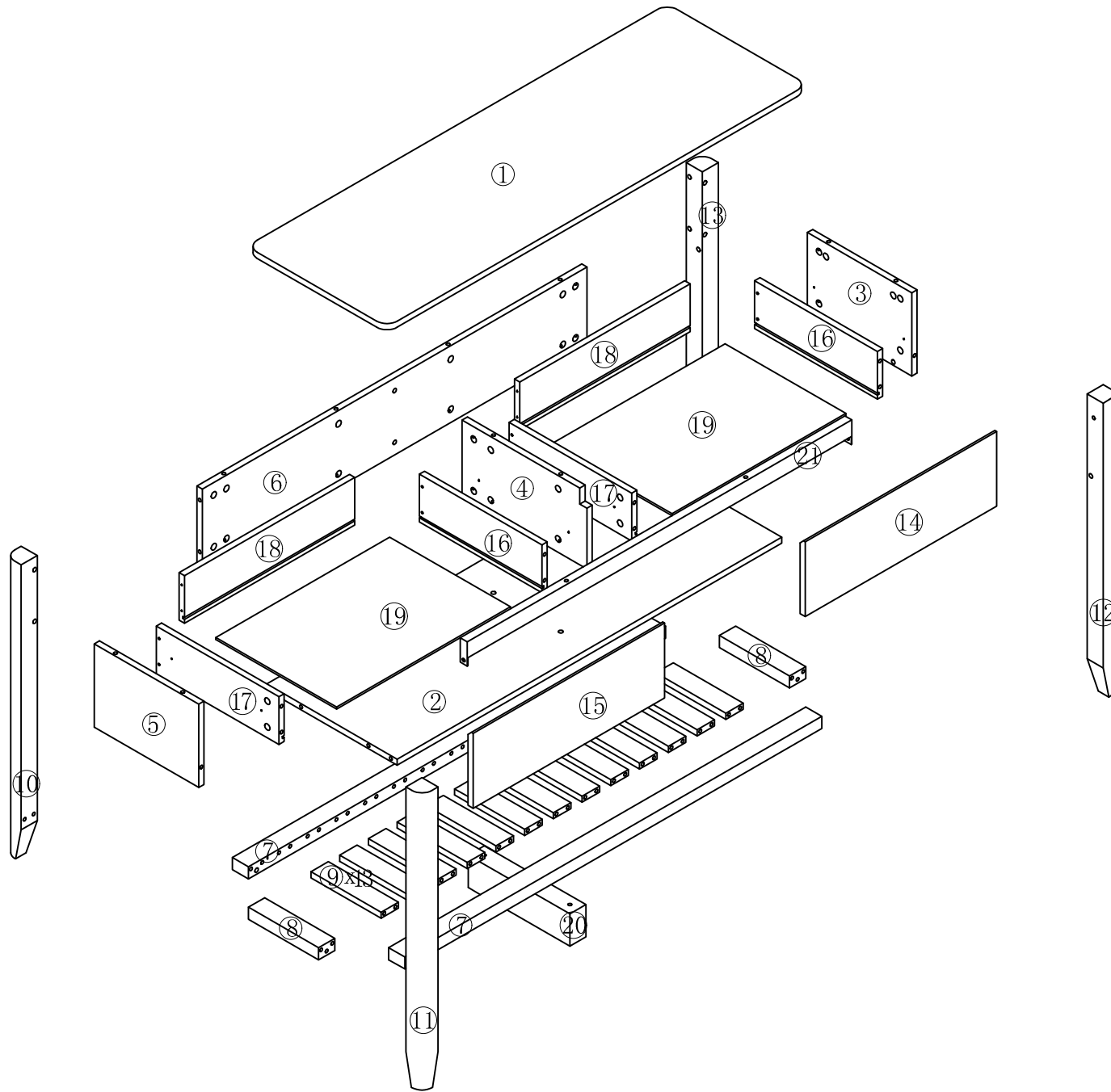

Cam Coupling Using Methods

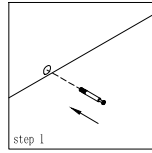

Step1.
Connect the cam coupling A as directed in the assembly instructions using hand.

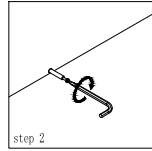

Step2.
Screw the cam coupling A as directed in the assembly instructions.

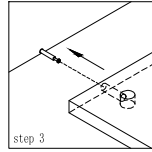

Step3.
Push the cam coupling A into the entry hole.

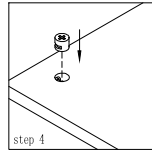

Step4.
Insert the cam coupling B as shown in the instructions.

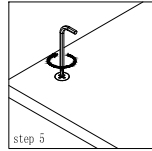

Step5.
Turn the cam coupling B clockwise with a screwdriver

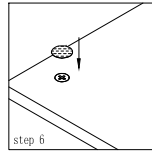

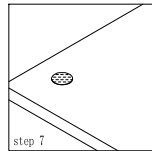

Step6.
Put on Beautycam.



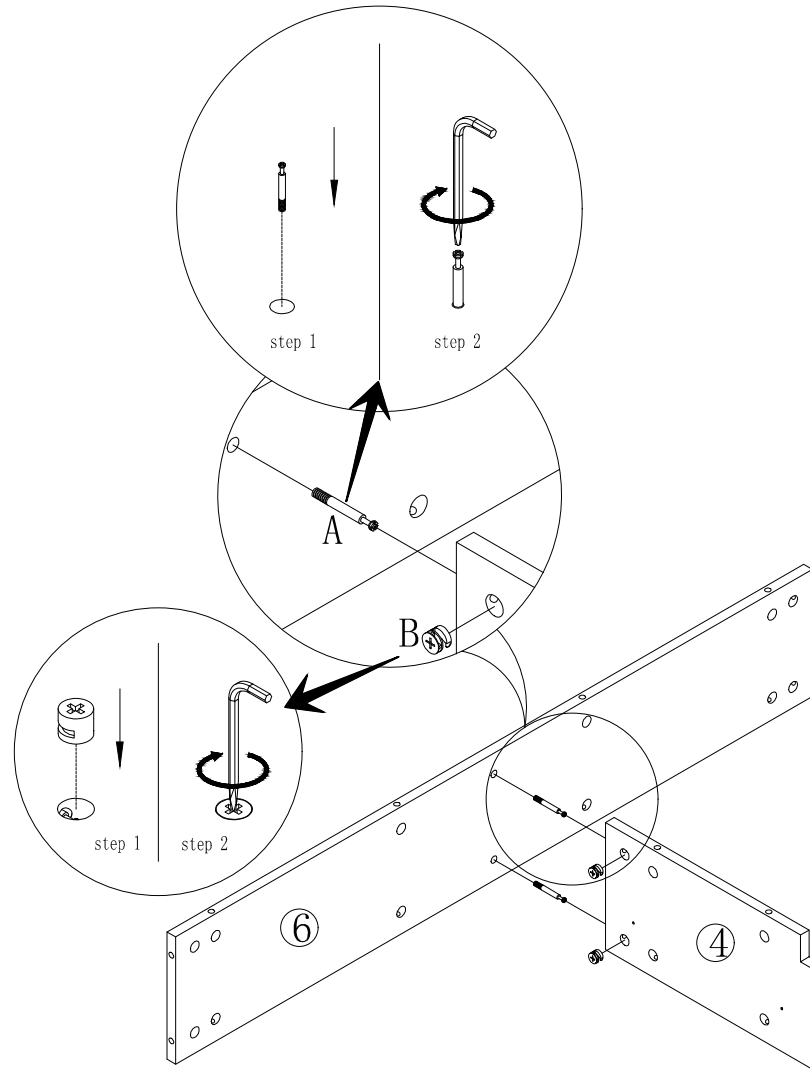

Step7.
Finished.

You should feel a click when the camlock is locked in place.
The joint is now secure.



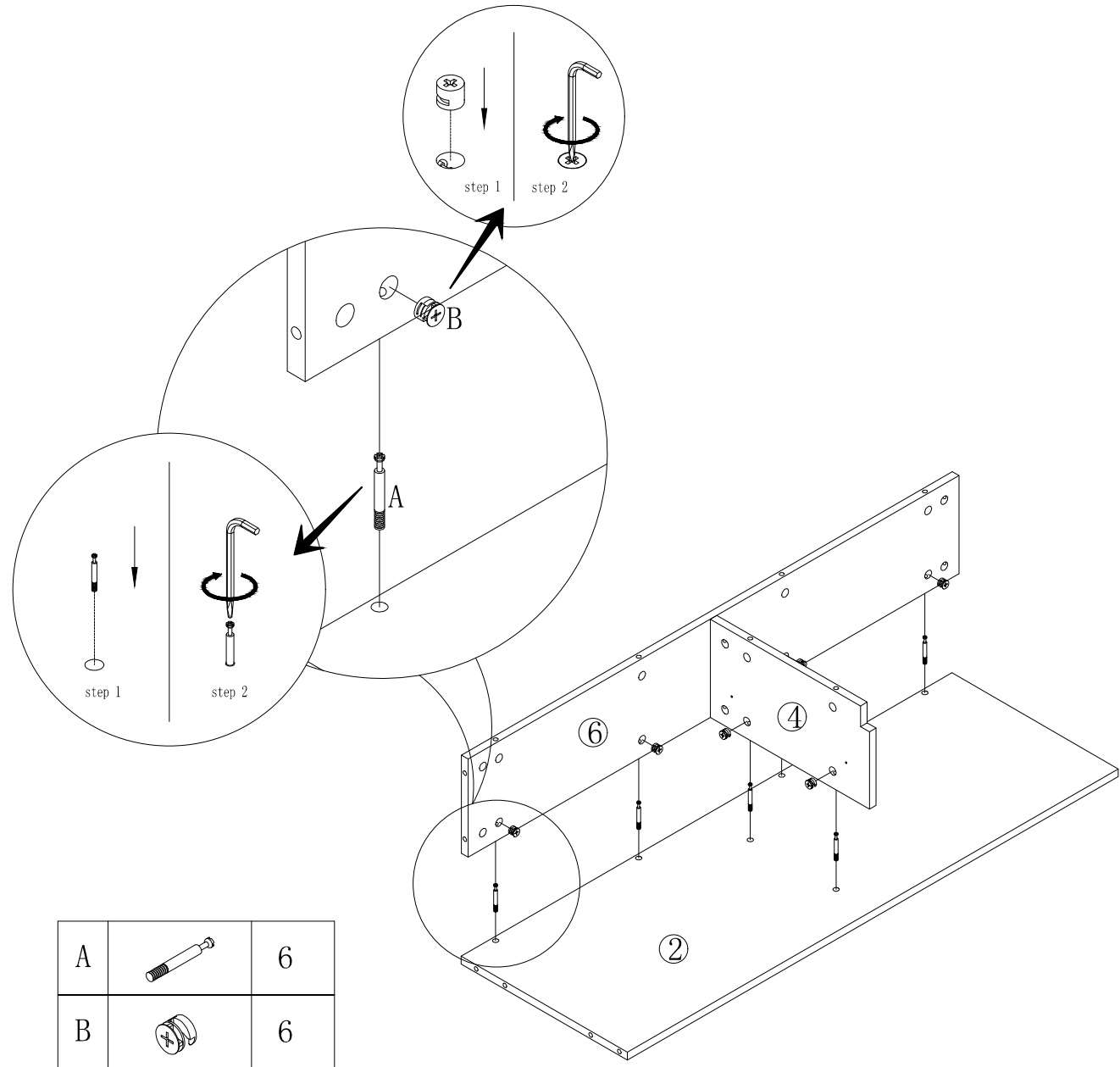

A		2
B		2

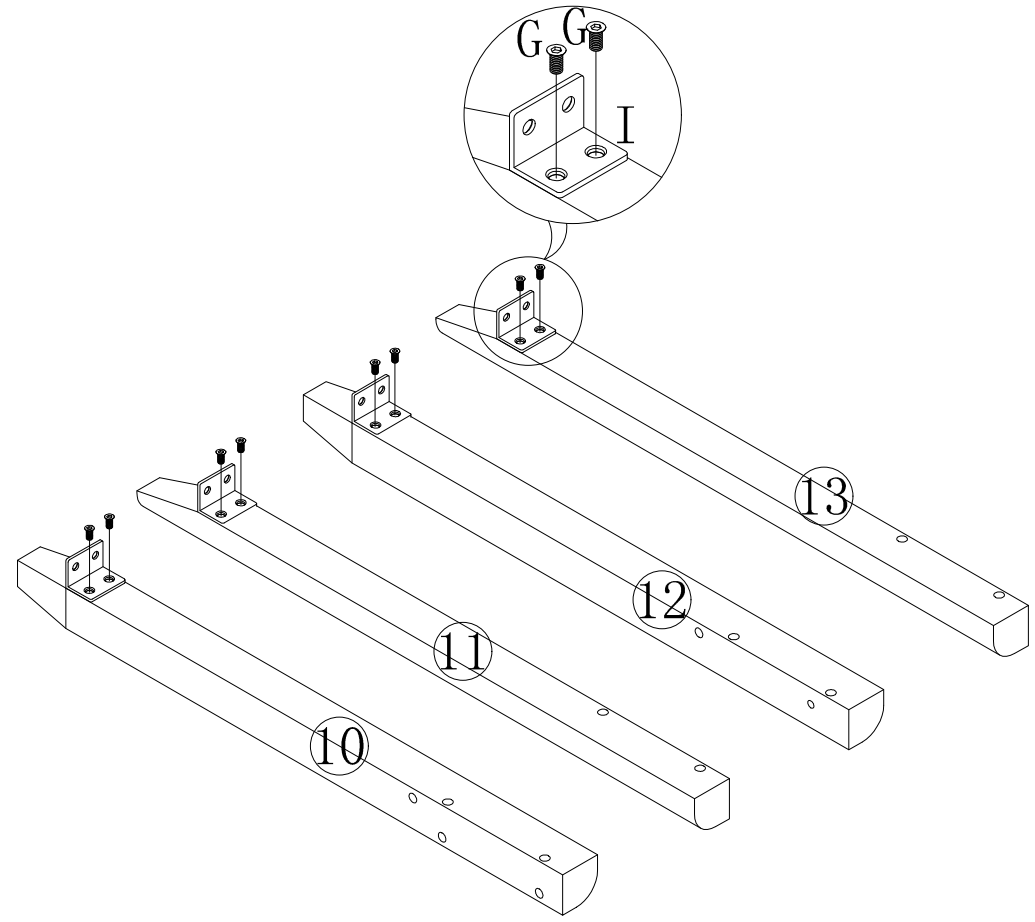

A		6
B		6



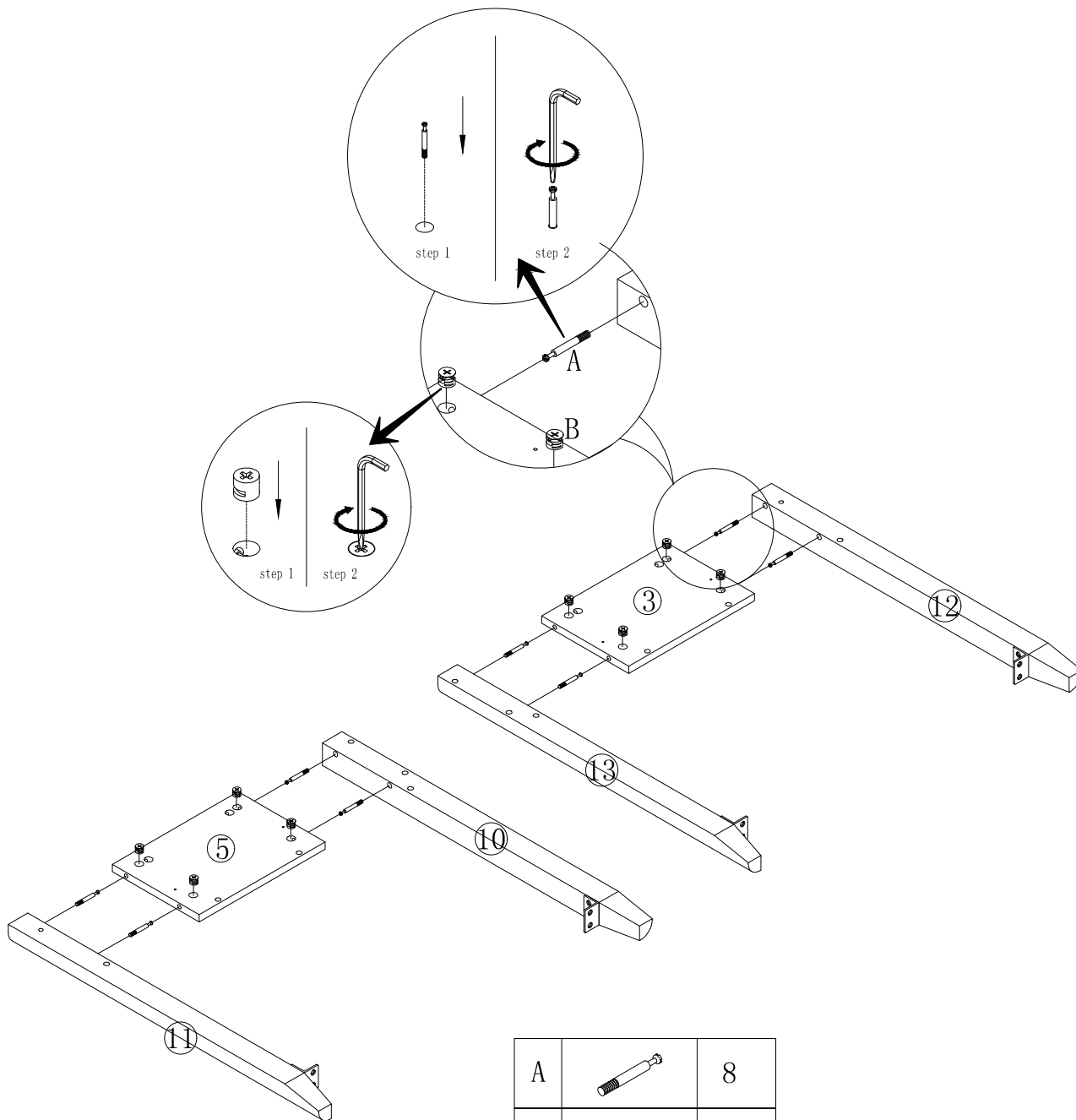

G	 6*12mm	8
I		4

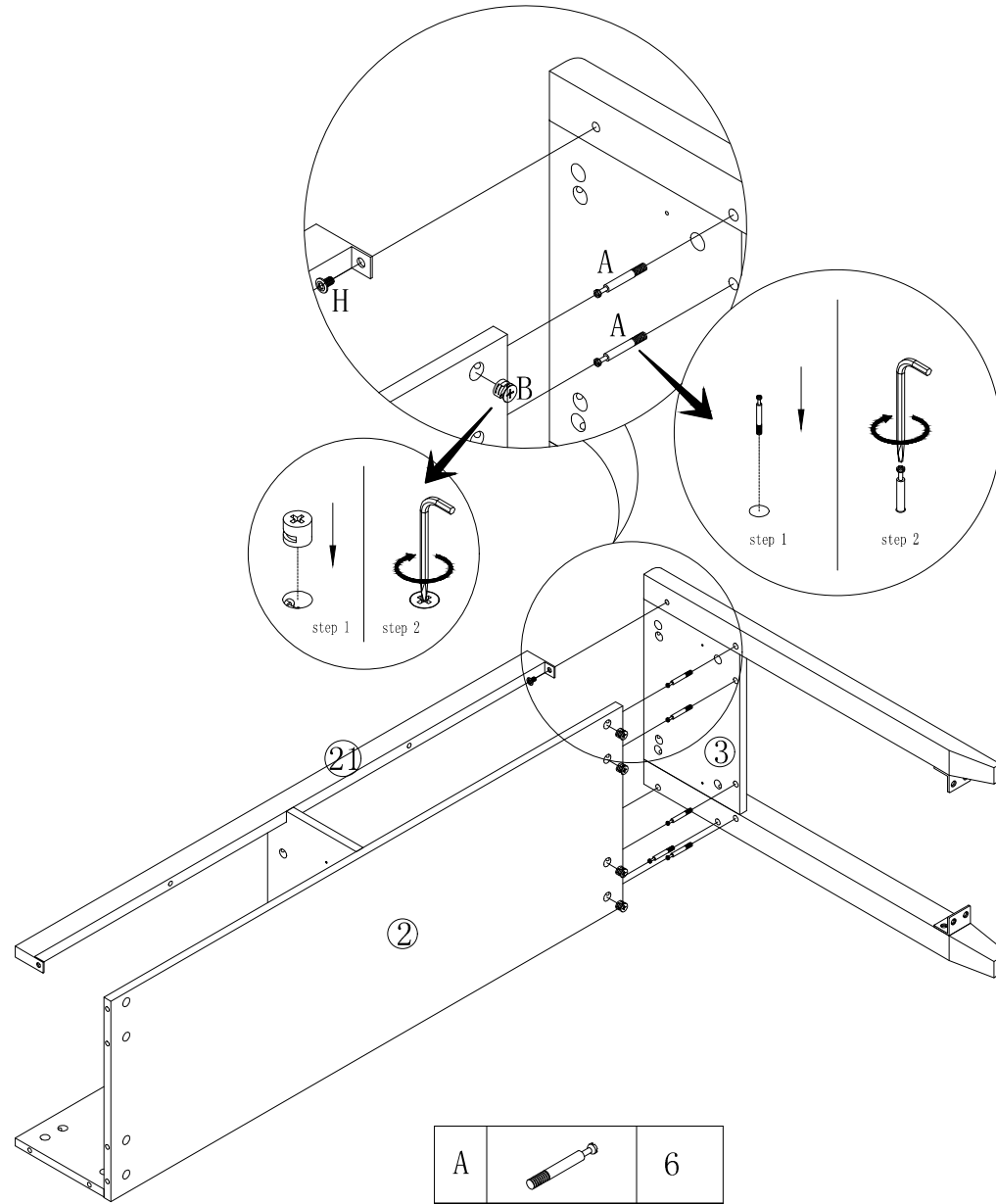

A		8
B		8



A		6
B		6
H	 6*1.2mm	1

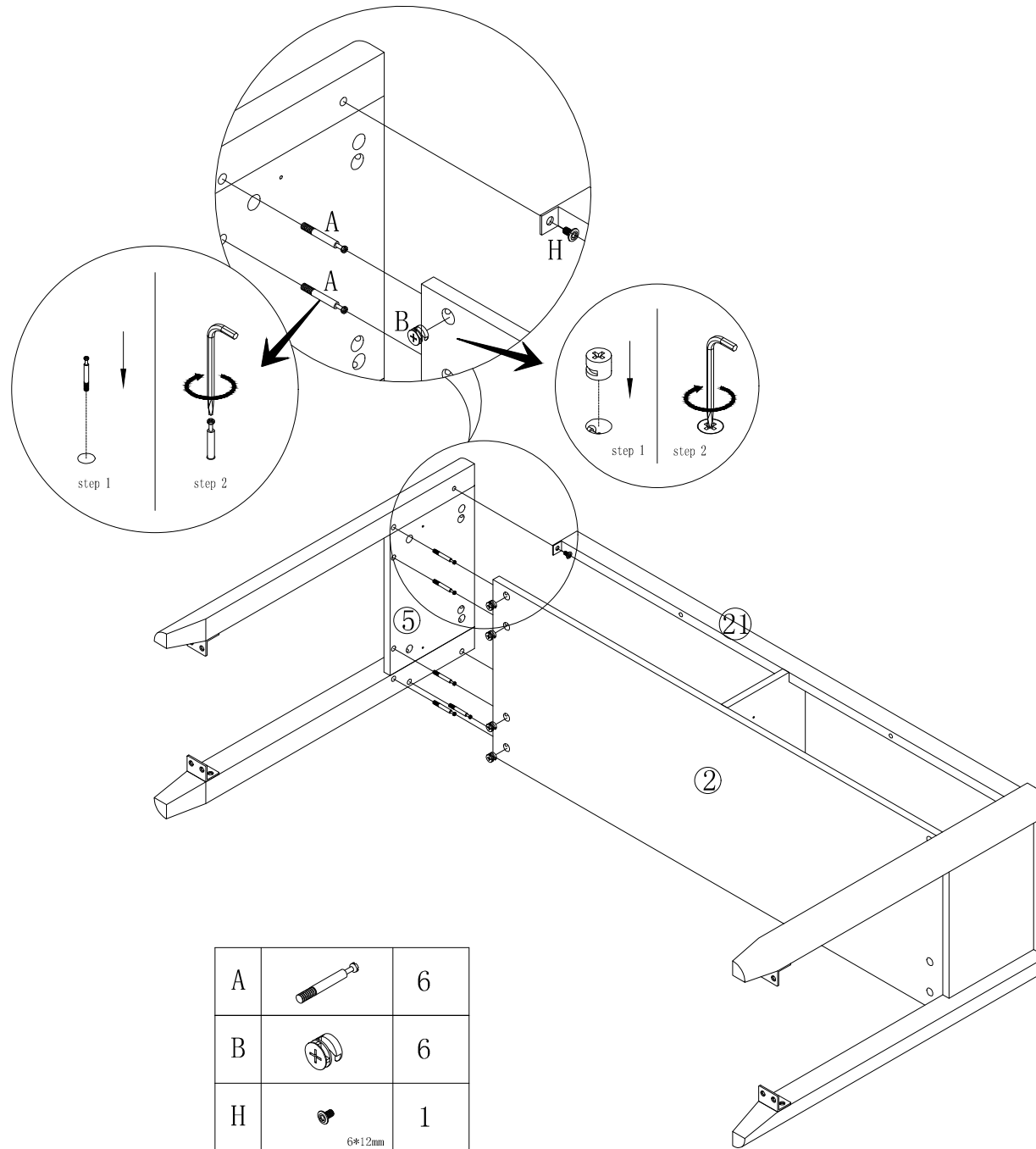

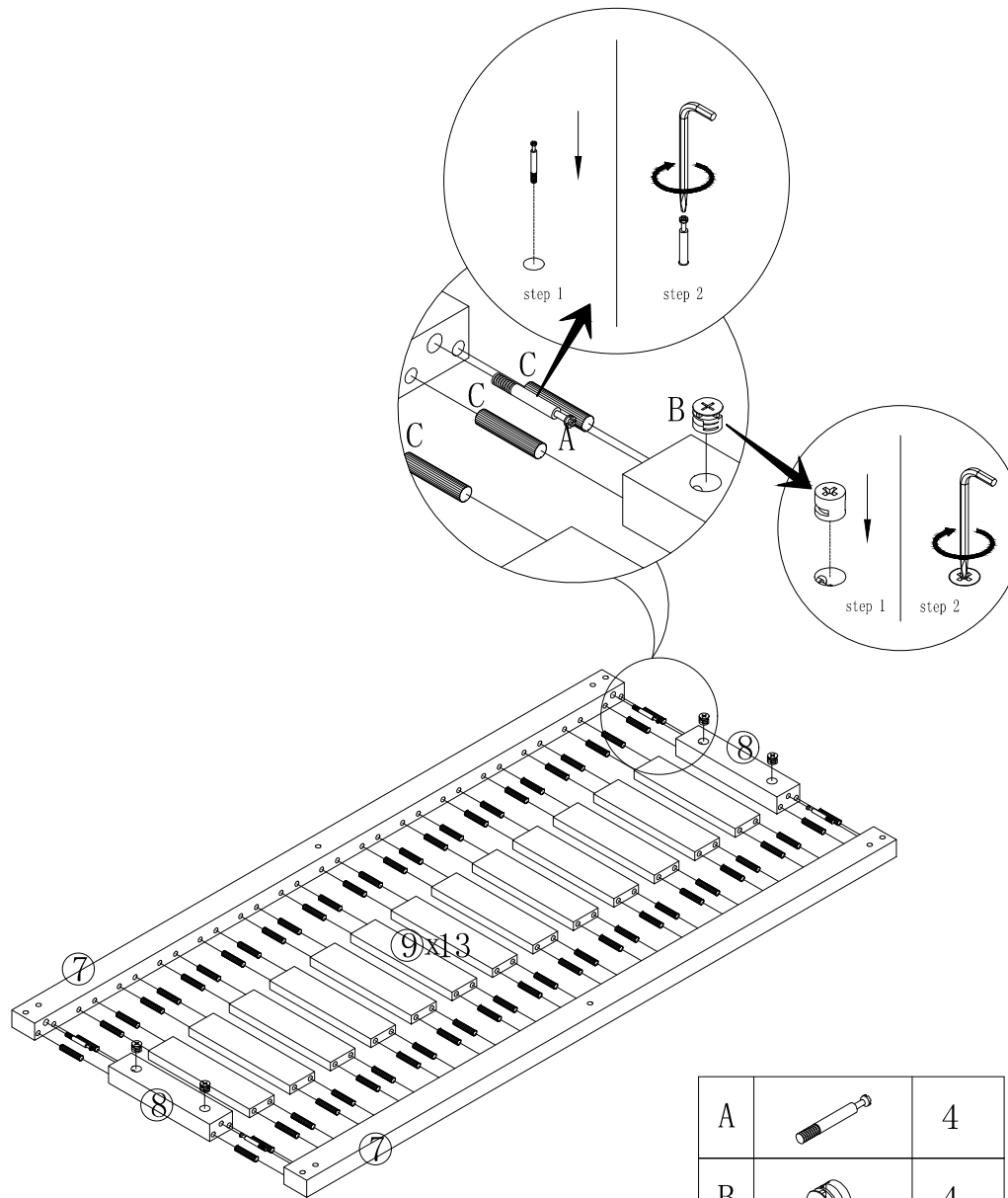

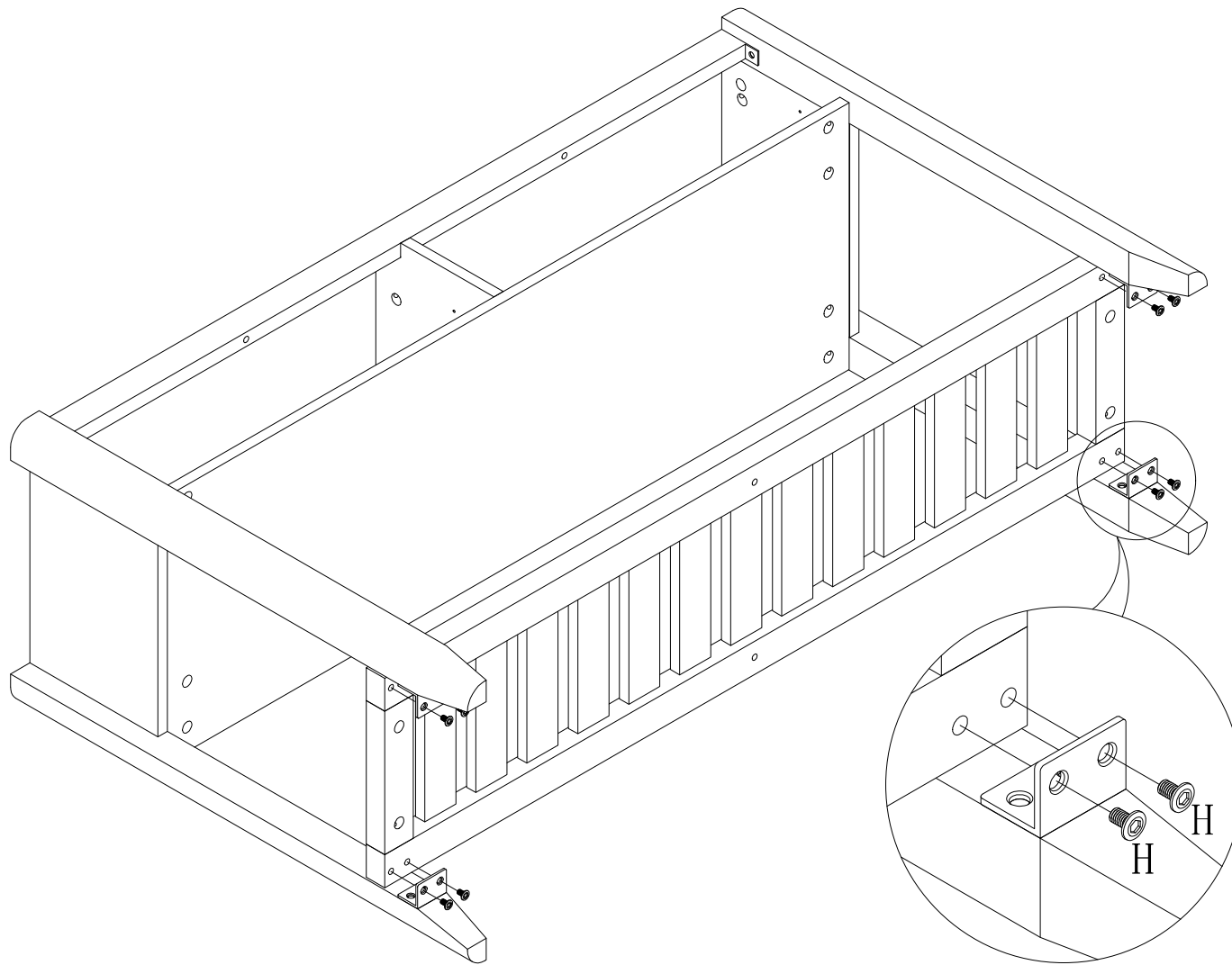

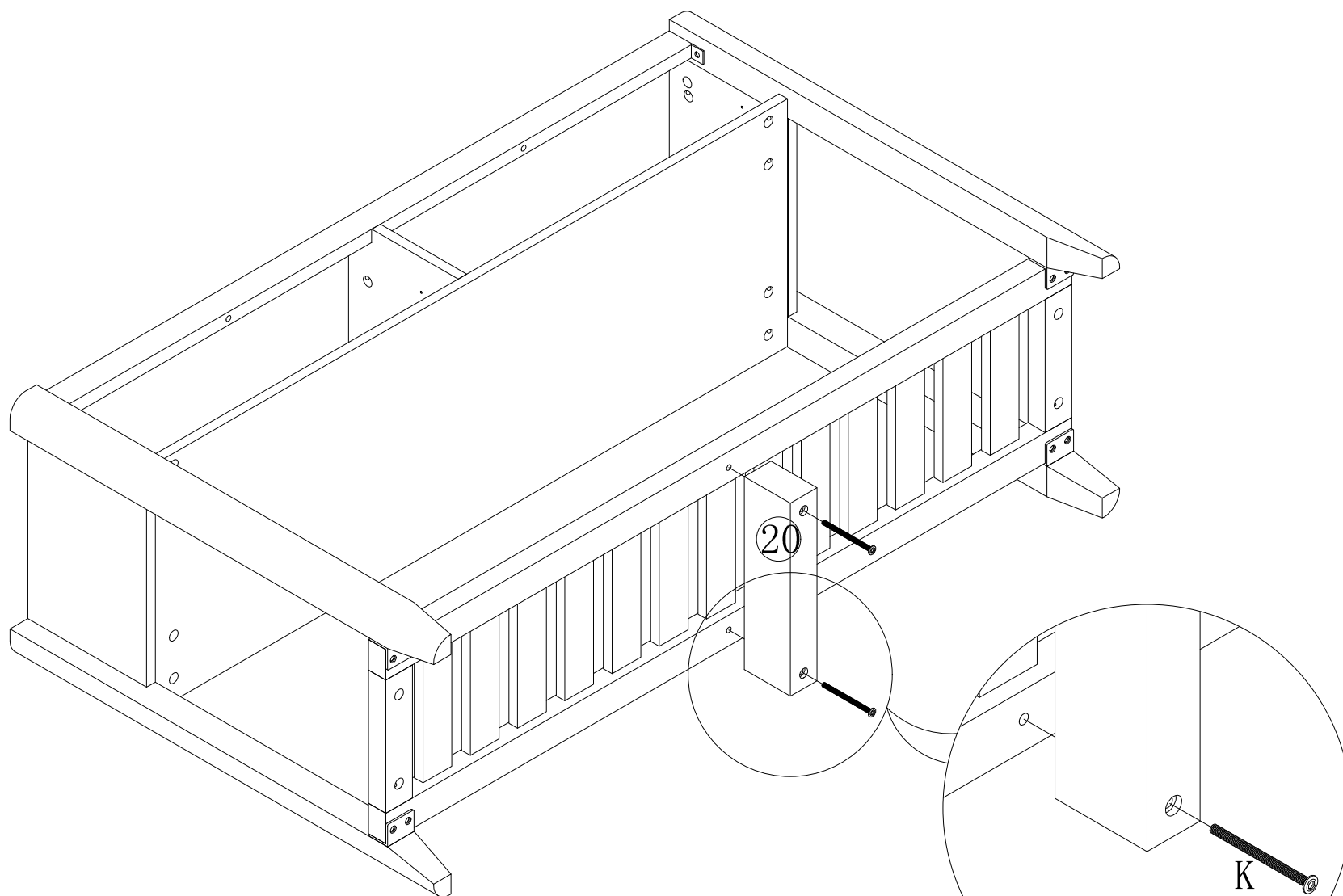

H	 6*12mm	8
---	---	---



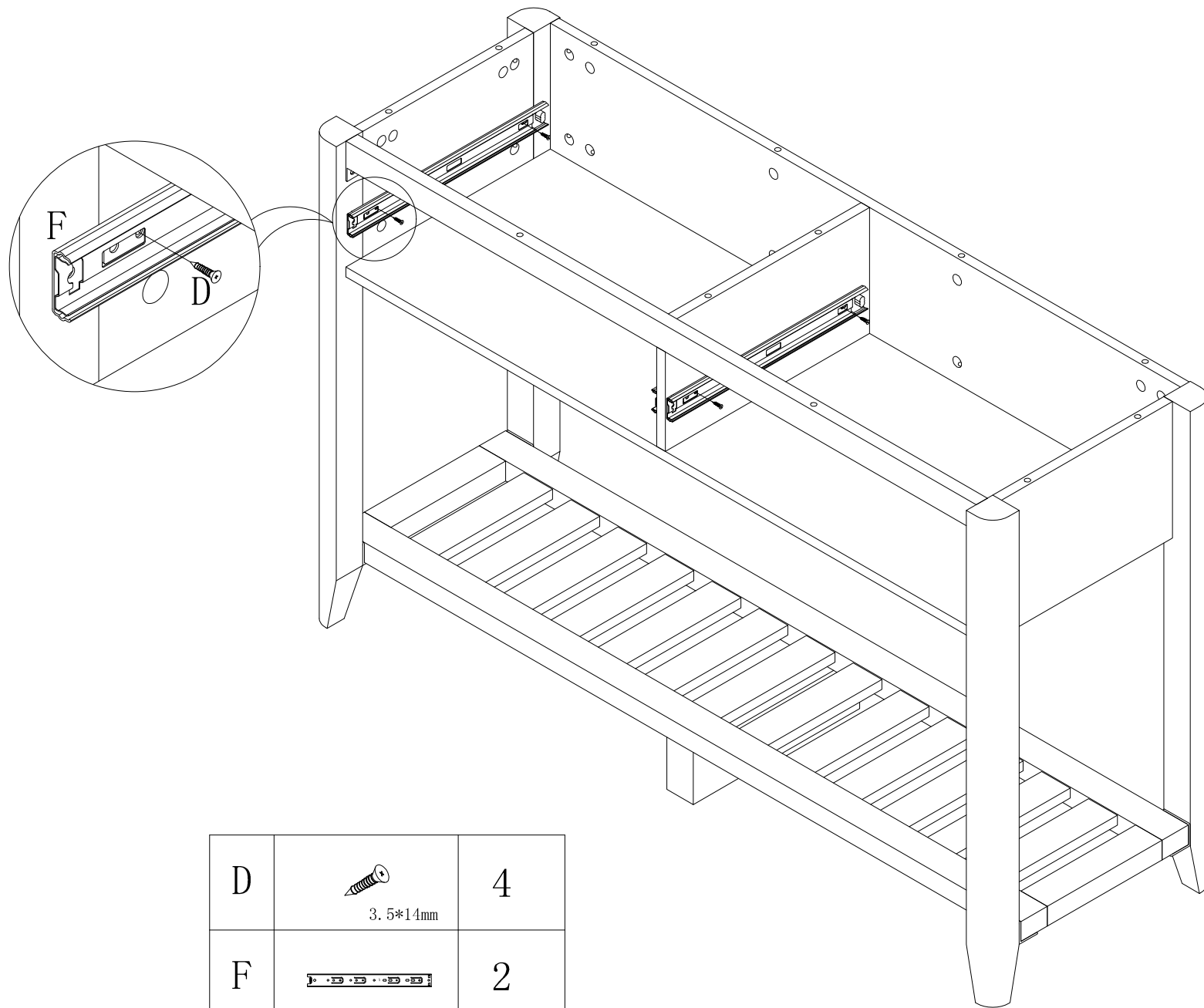

K		8
	6*8.5mm	



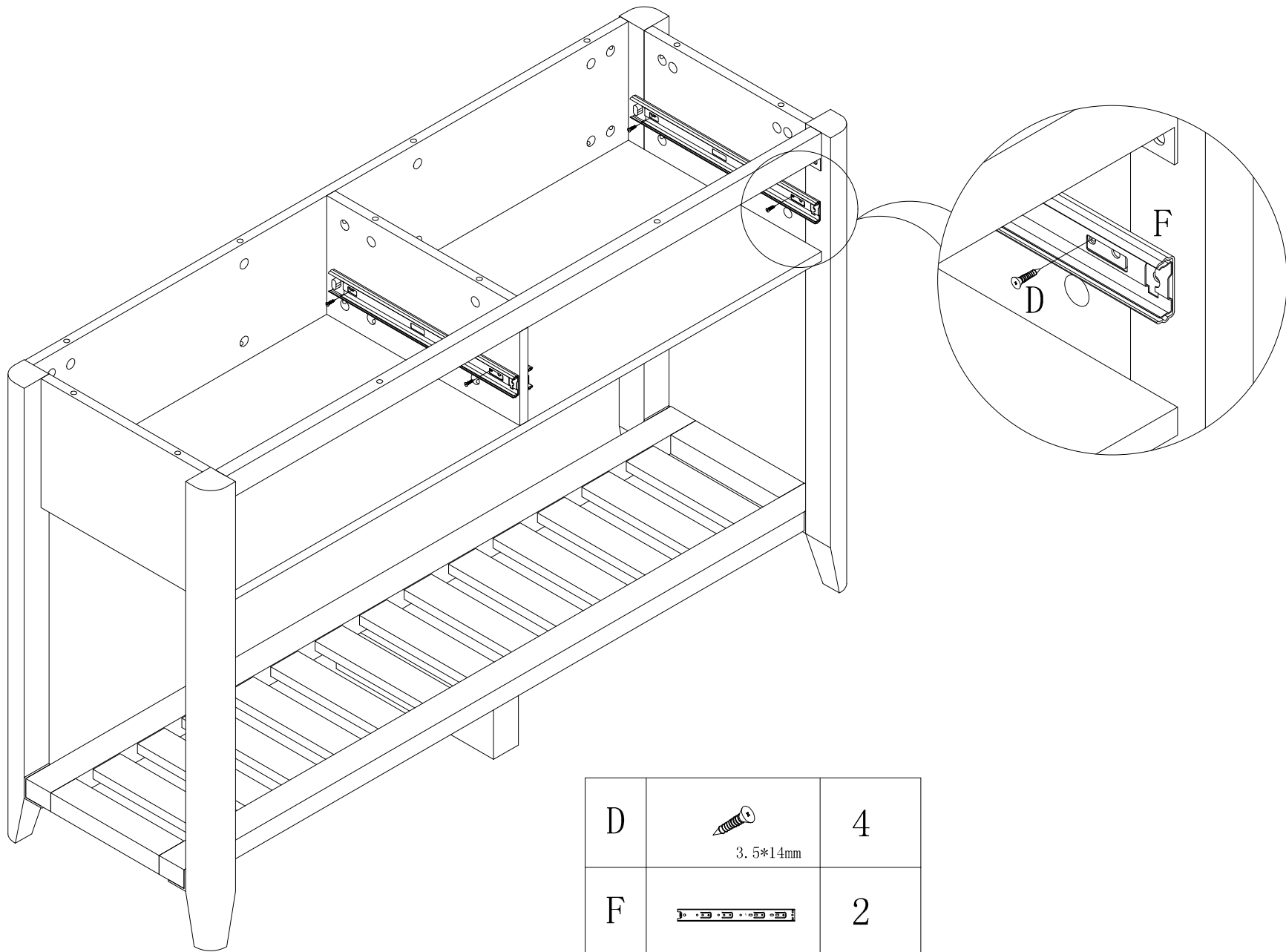

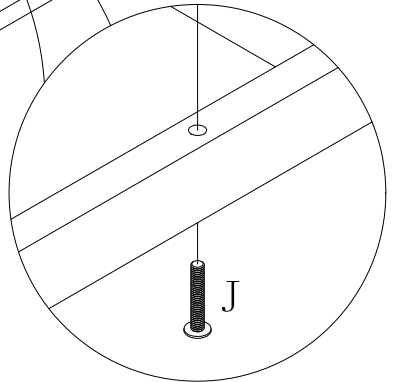
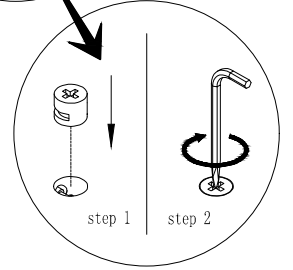
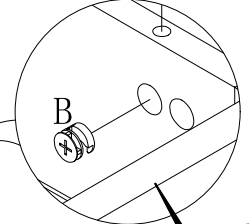
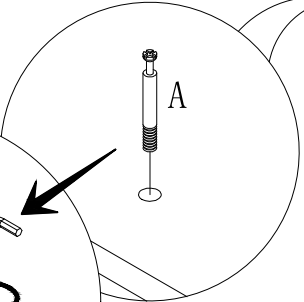
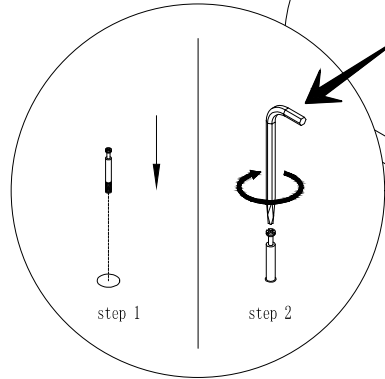
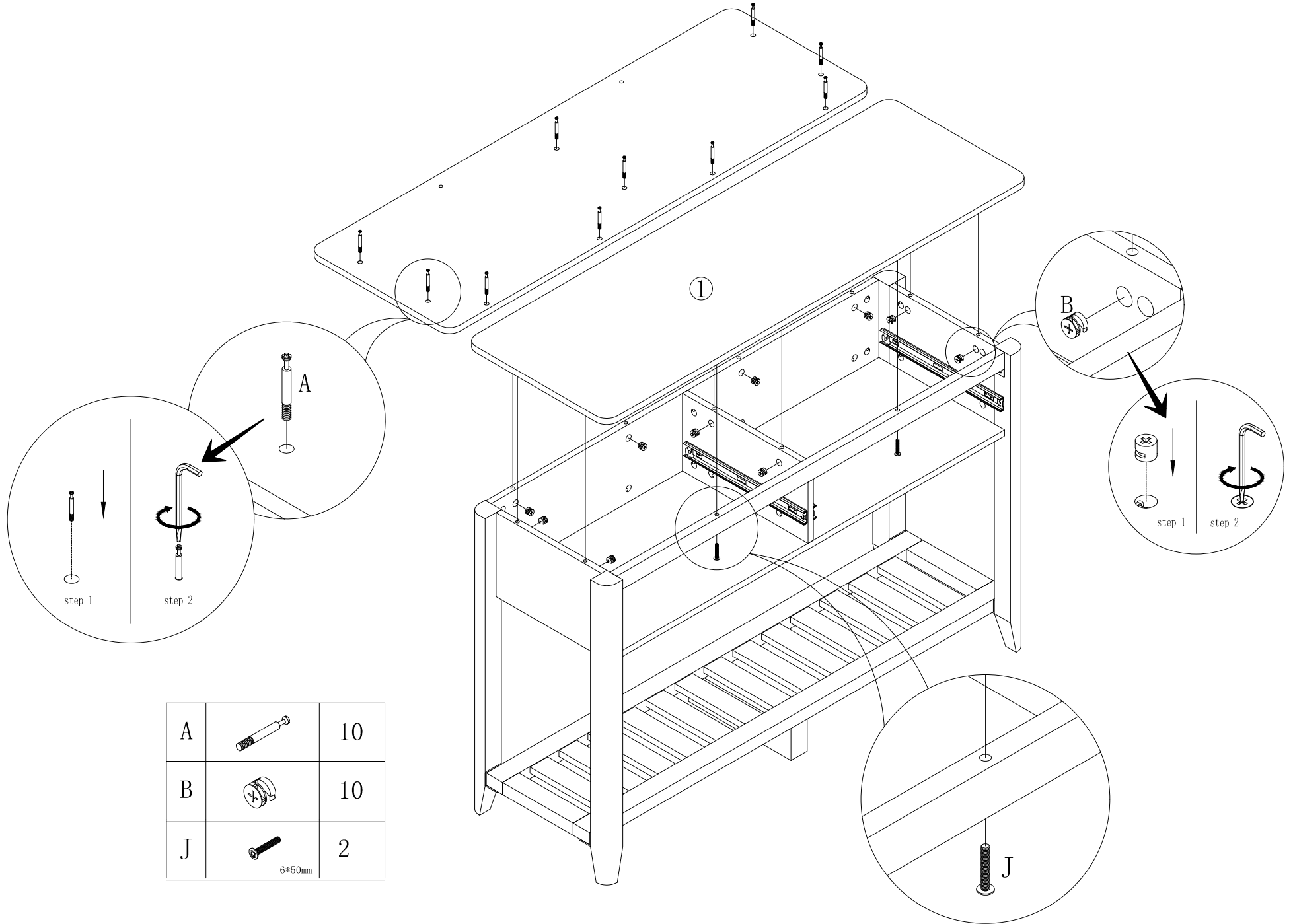
D	 3.5*14mm	4
F		2

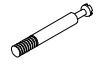



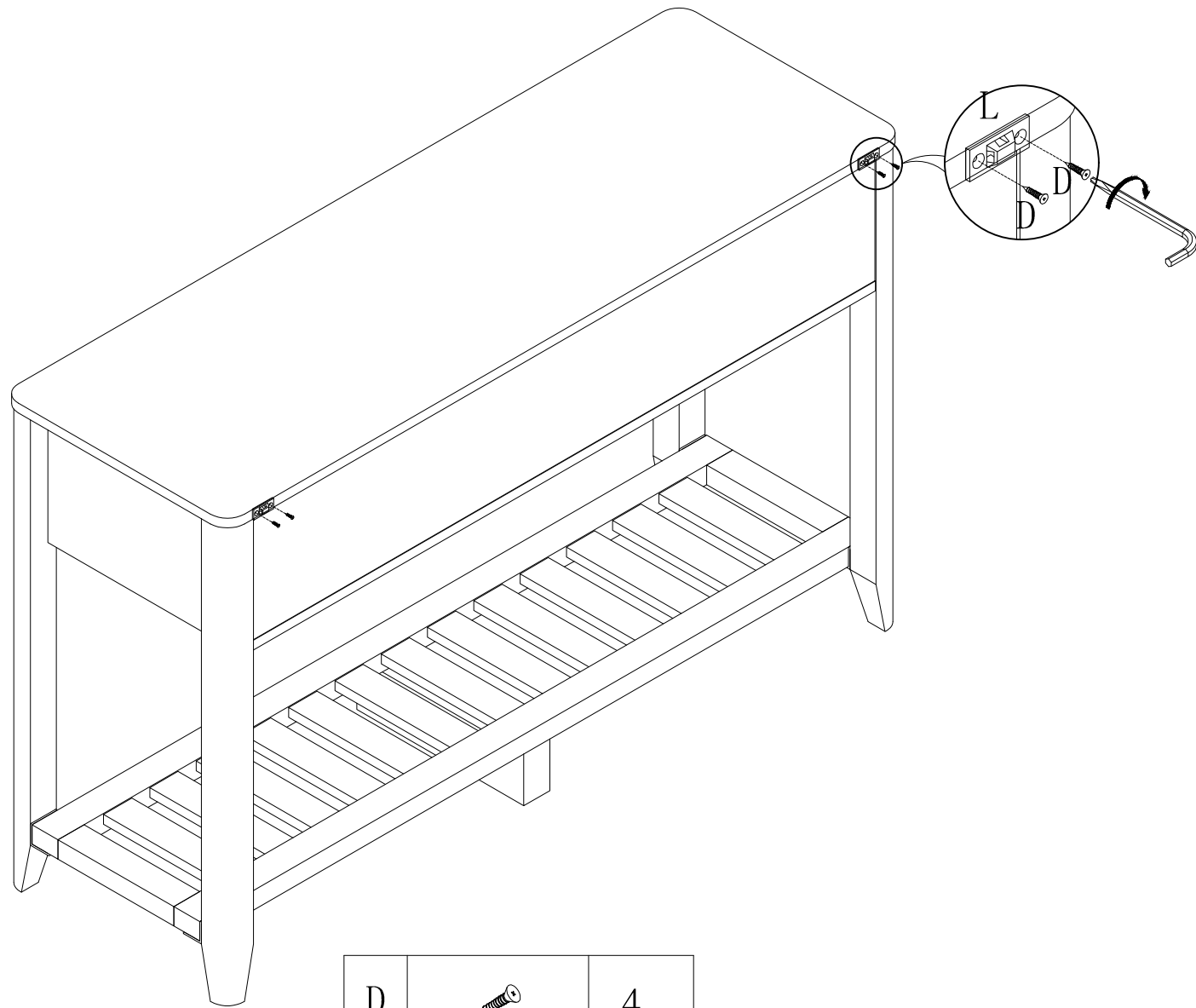

A		10
B		10
J	 6*50mm	2



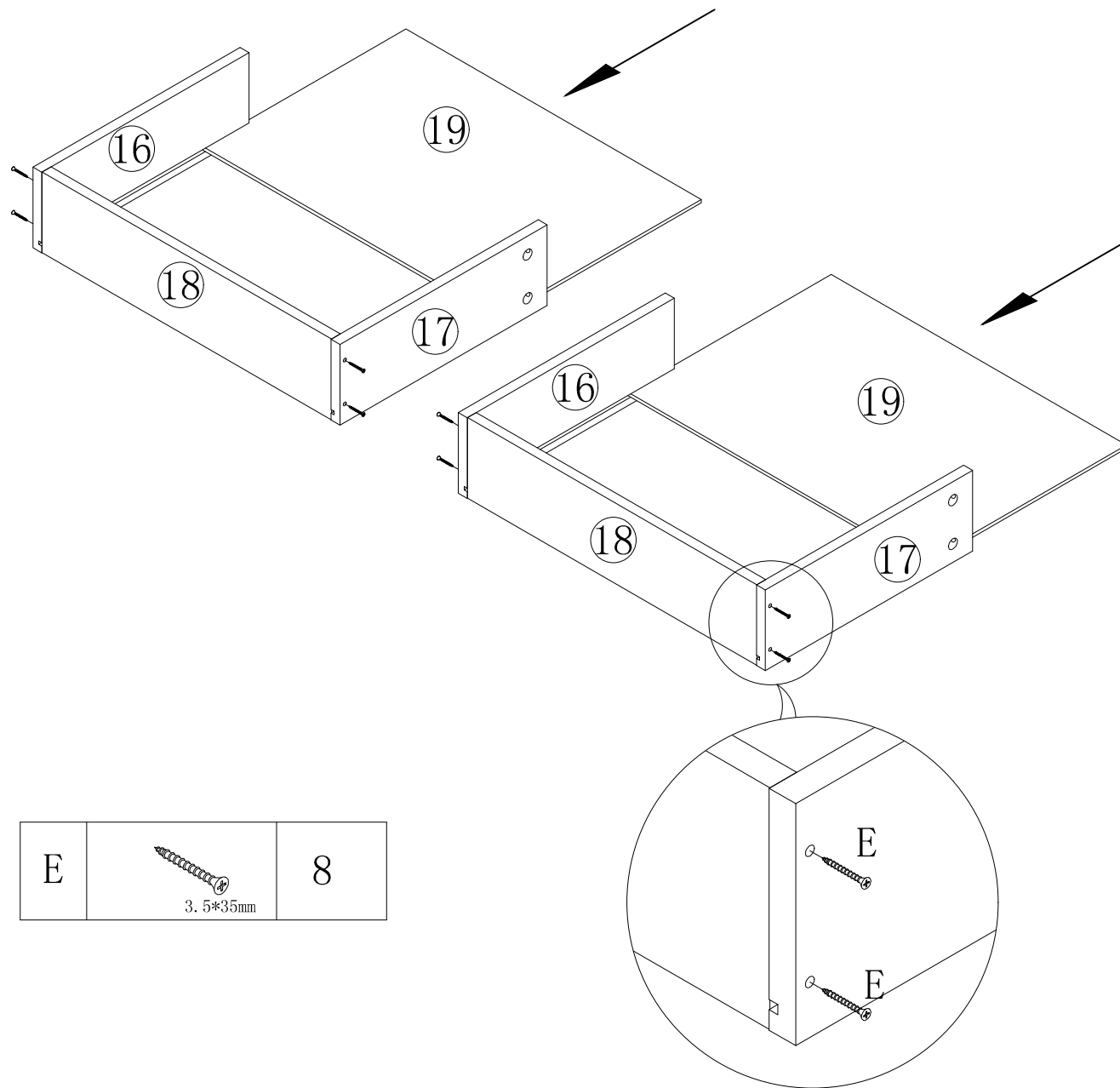

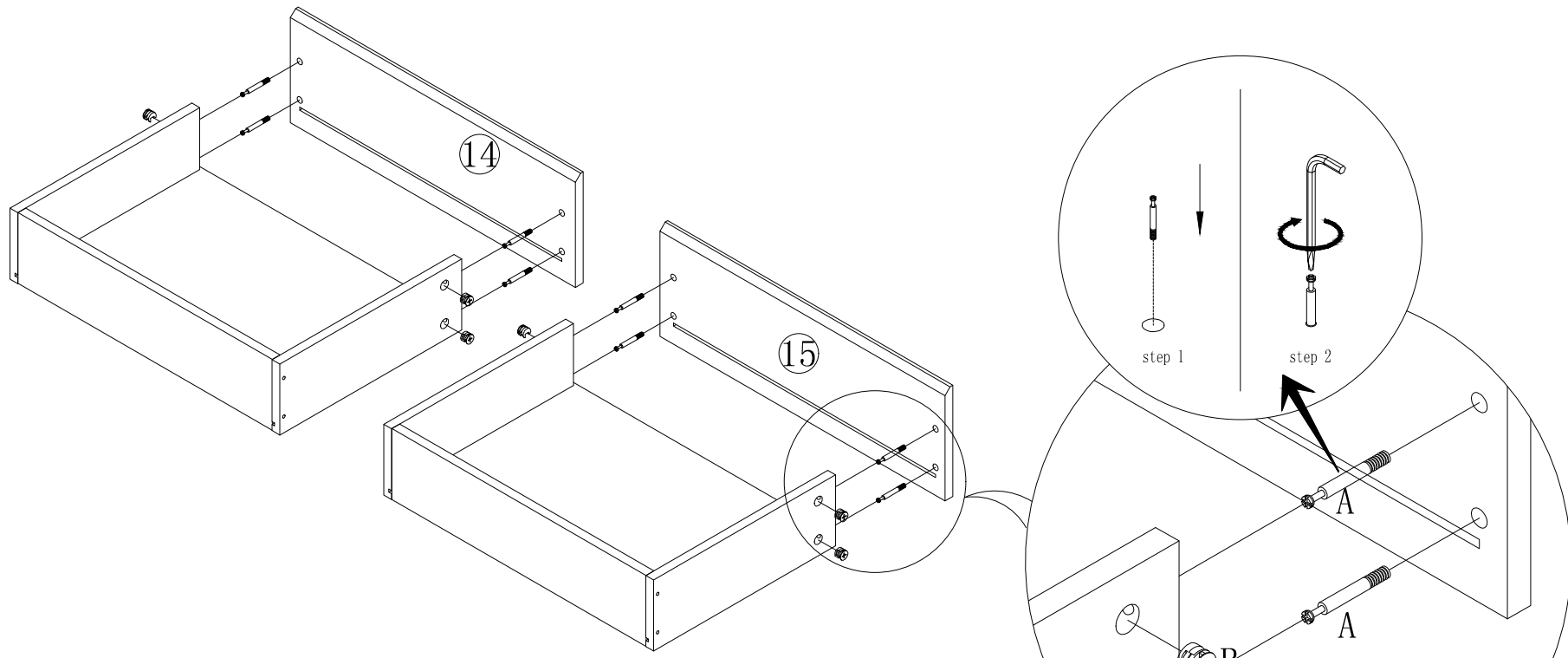
D	 3.5*14mm	4
L	 3.5*35mm 3.5*14mm	2



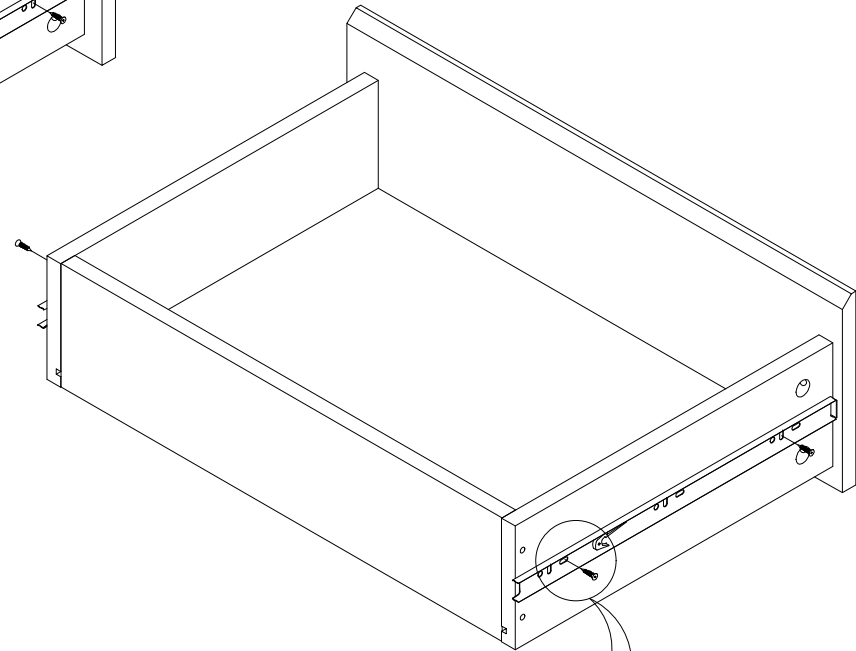
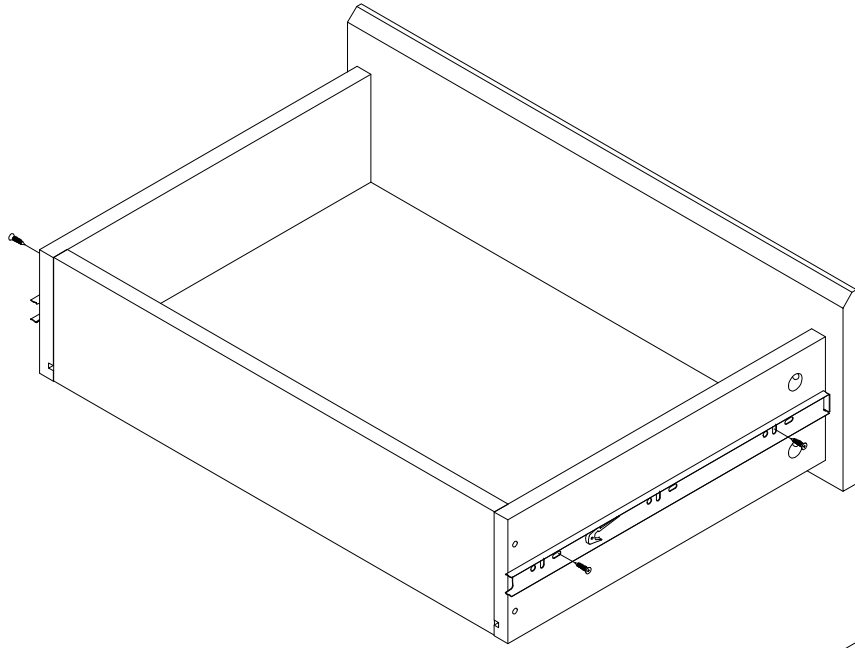

A		8
B		8



D	 3.5*14mm	8
F		4

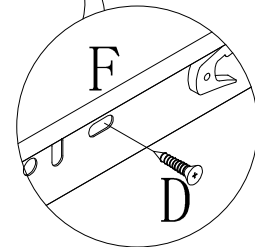

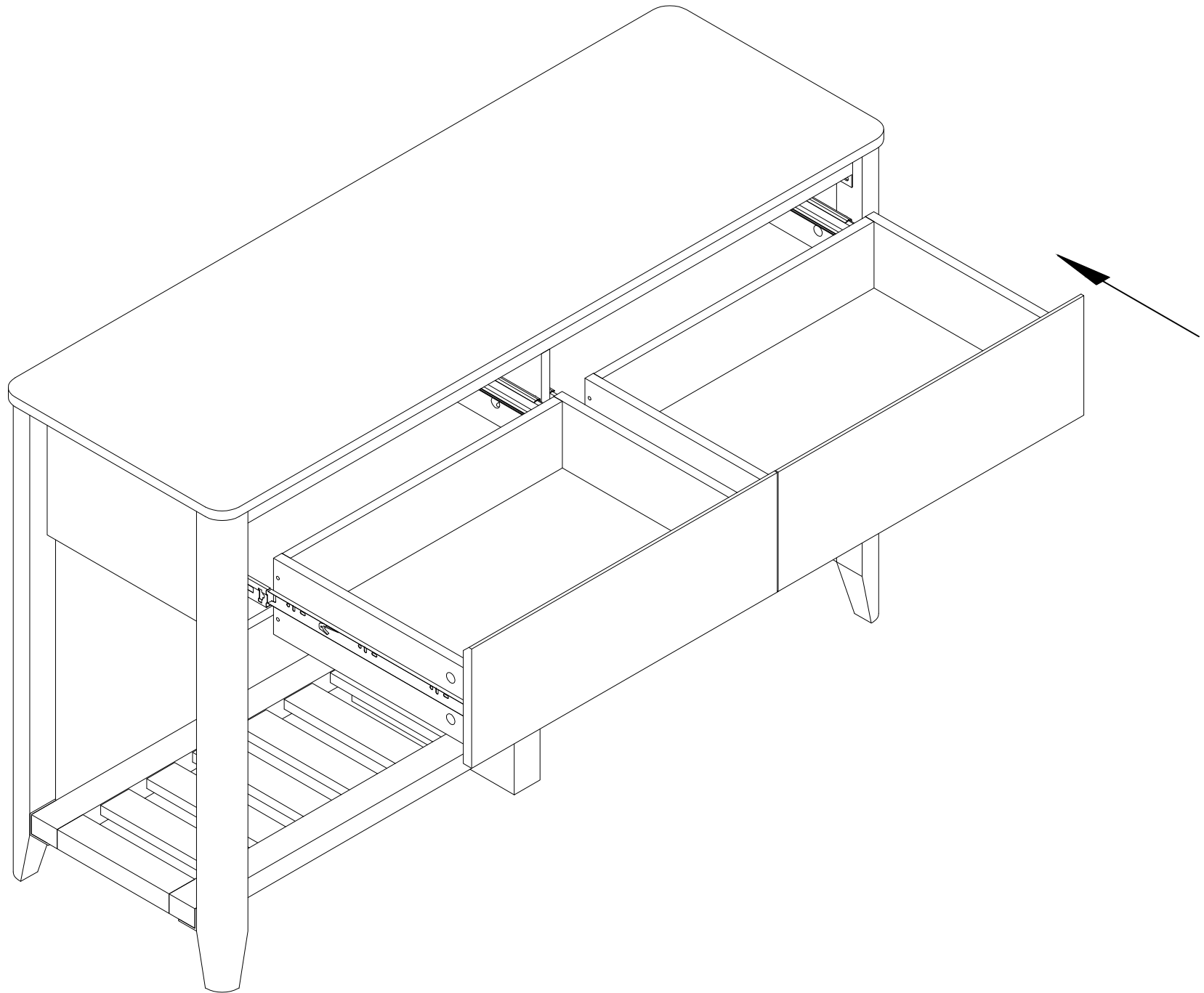

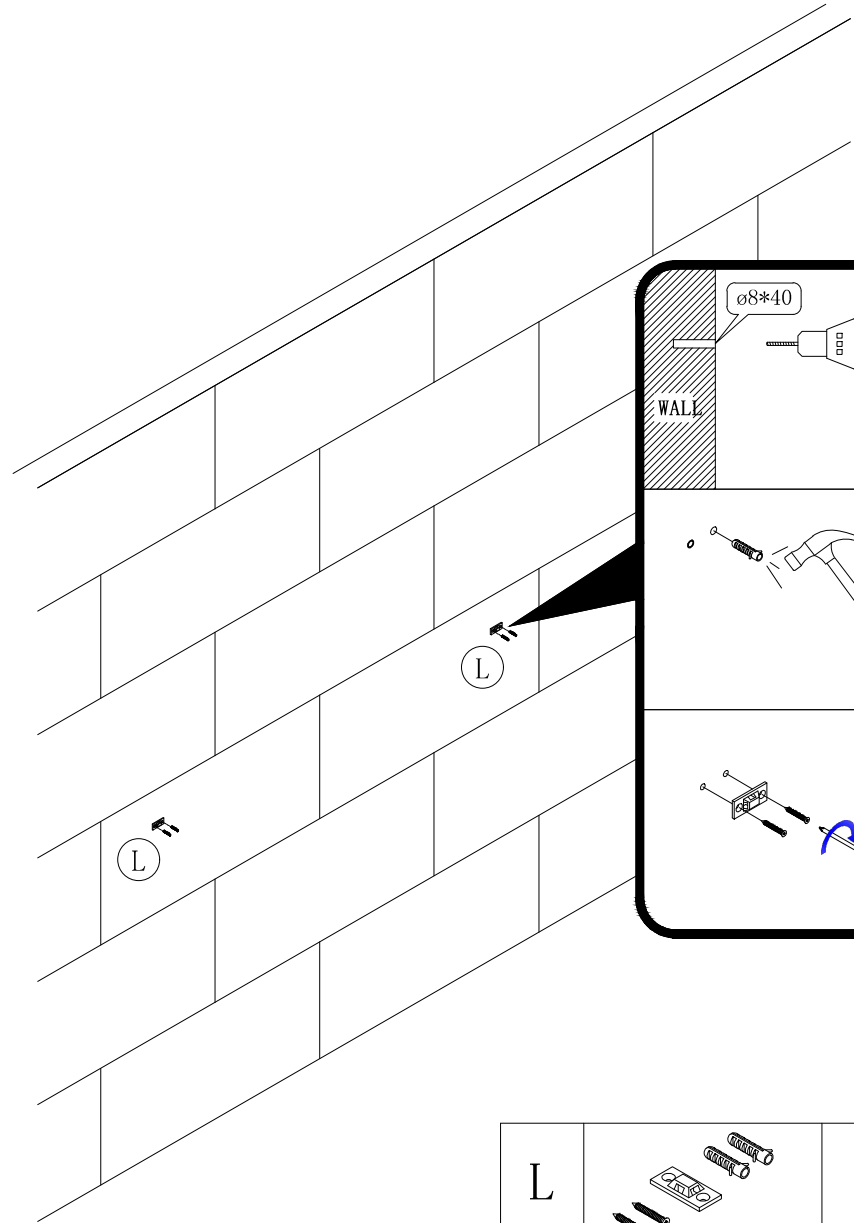

Step 1

ø8*40

WALL

Step 2

Step 3

L	 3.5*35mm	*2
---	--------------	----

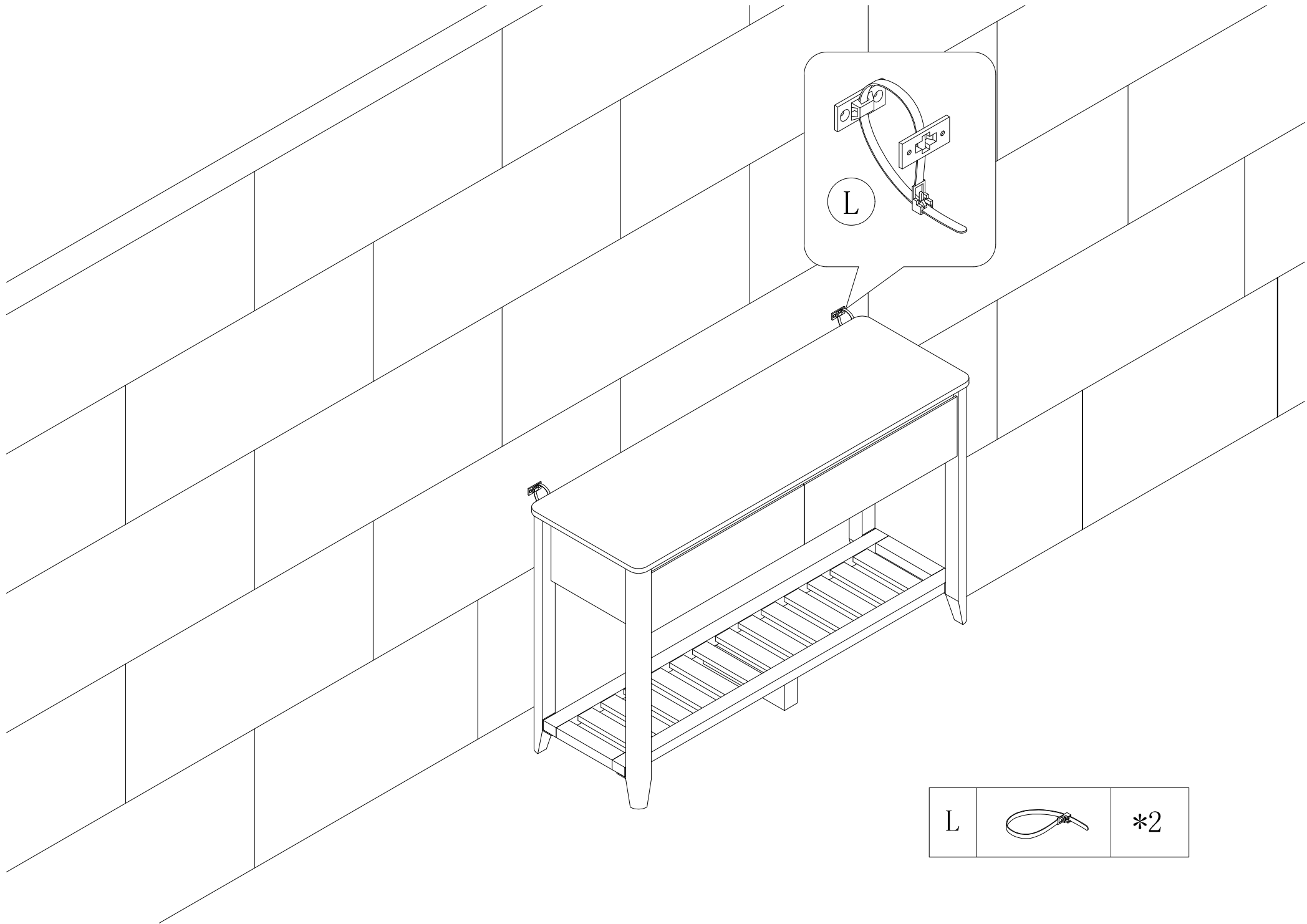

L		*2
---	---	----