



















Parts List



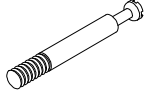

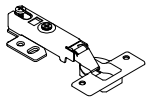

| NO. | Drawing | Dimension | QTY |
|-----|---|--------------|-----|
| 1 |  | 700*400*15mm | 1 |
| 2 |  | 650*380*15mm | 1 |
| 3 |  | 650*380*15mm | 1 |
| 4 |  | 650*380*15mm | 1 |
| 5 |  | 700*400*15mm | 1 |
| 6 |  | 324*364*15mm | 4 |
| 7 |  | 700*240*15mm | 1 |

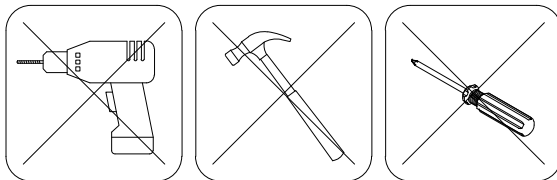
| NO. | Drawing | Dimension | QTY |
|-----|---|---------------|-----|
| 8 |  | 6667*238*15mm | 2 |
| 9 |  | 885*238*15mm | 1 |
| 10 |  | 885*238*15mm | 1 |
| 11 |  | 646*348*15mm | 1 |
| 12 |  | 646*348*15mm | 1 |
| 13 |  | 3677*295*4mm | 3 |
| 14 |  | 660*336*4mm | 2 |

Hardware Fitting

| NO. | Drawing | QTY |
|-----|---|-----|
| A |  | 28 |
| B |  | 28 |
| C |  | 4 |
| D |  3.5*14mm | 36 |
| E |  | 44 |

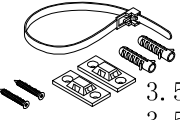

| NO. | Drawing | QTY |
|-----|---|-----|
| F |  3.0*14mm | 44 |
| G |  | 16 |
| H |  | 2 |
| I |  6*15mm | 4 |
| J |  120H | 4 |
| K |  3.5*35mm 3.5*14mm | 2 |
| |  | 1 |

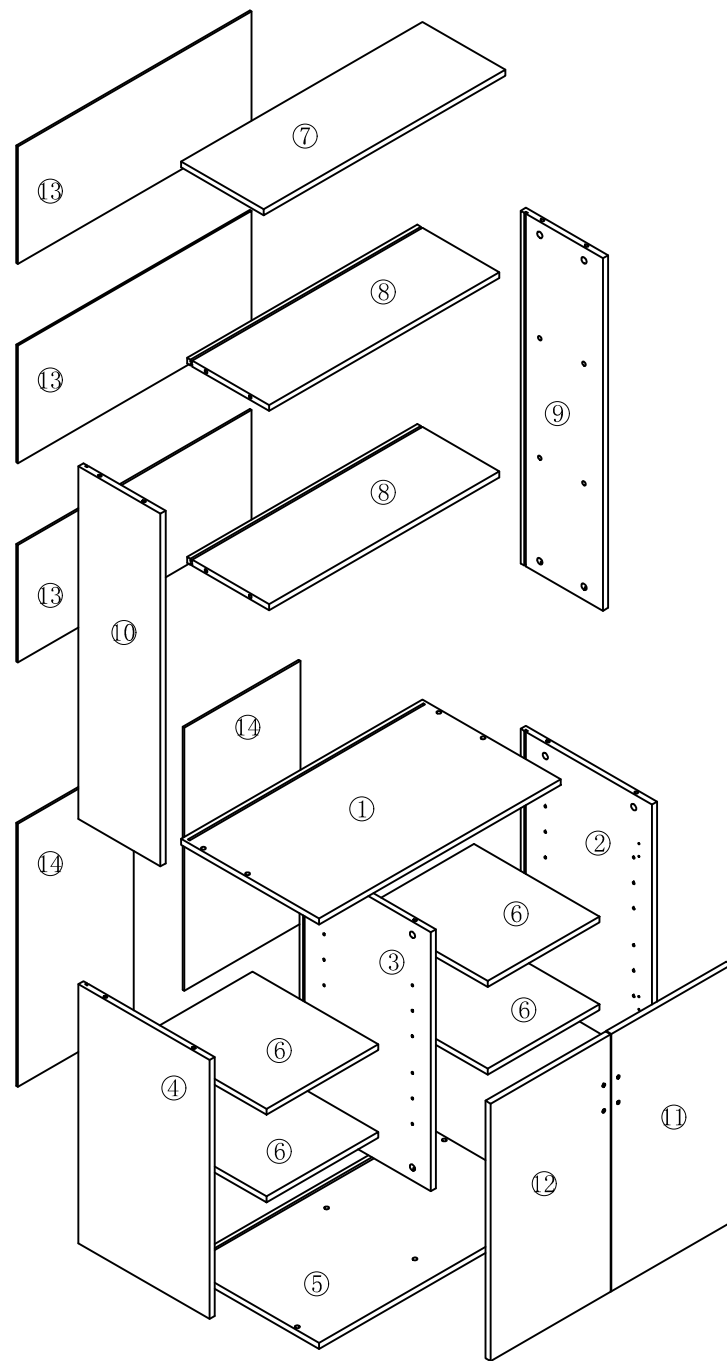

Cam Coupling Using Methods

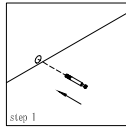

Step1.

Connect the cam coupling A as directed in the assembly instructions using hand.

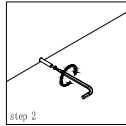

Step2.

Screw the cam coupling A as directed in the assembly instructions.

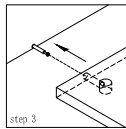

Step3.

Push the cam coupling A into the entry hole.

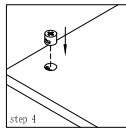

Step4.

Insert the cam coupling B as shown in the instructions.

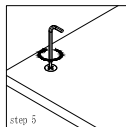

Step5.

Turn the cam coupling B clockwise with a screwdriver

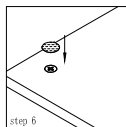

Step6.

Put on Beautycam.

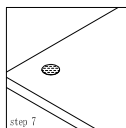



Step7.

Finished.

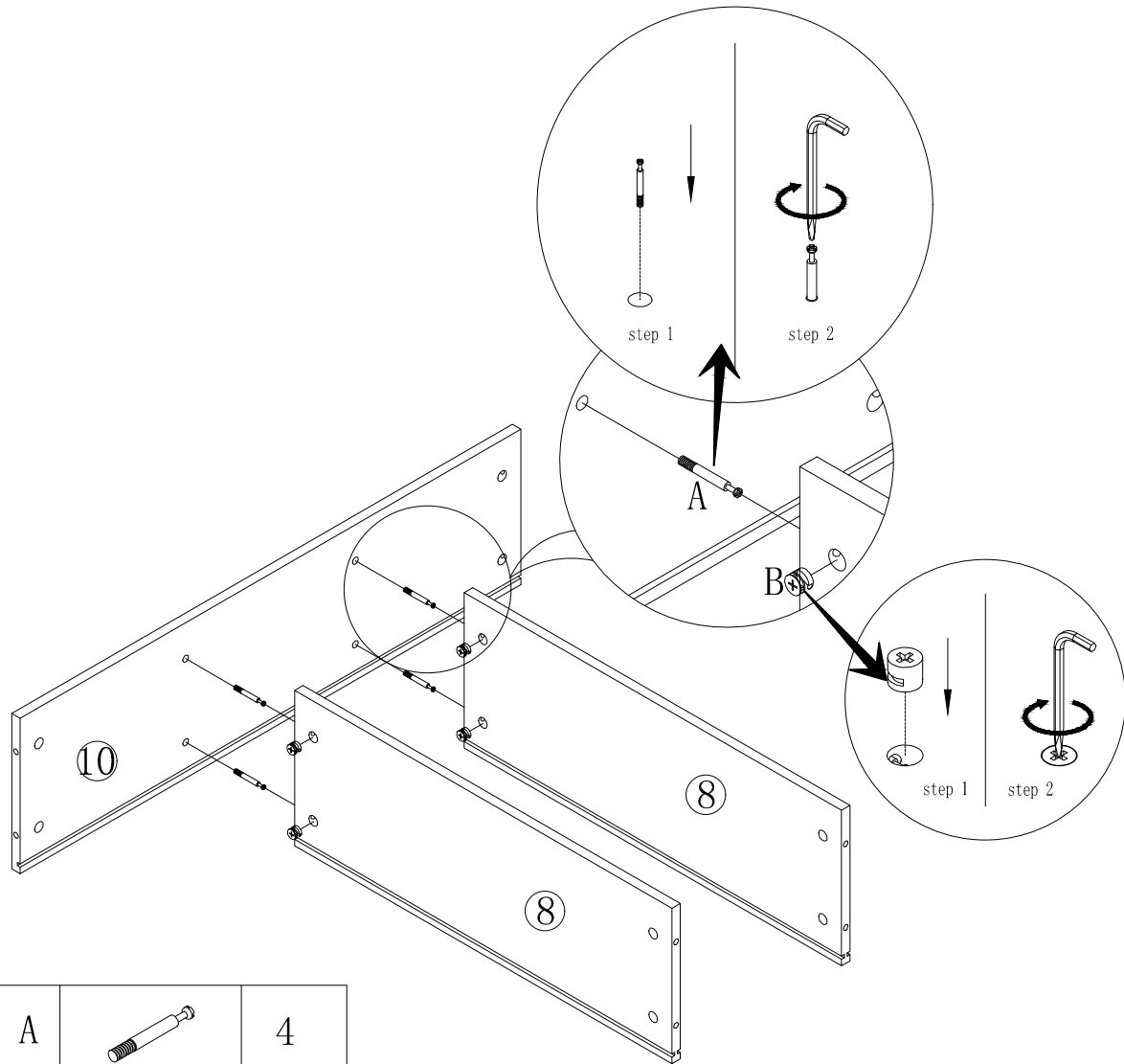
You should feel a click when the camlock is locked in place.
The joint is now secure.



| | | |
|---|---|---|
| A |  | 4 |
| B |  | 4 |

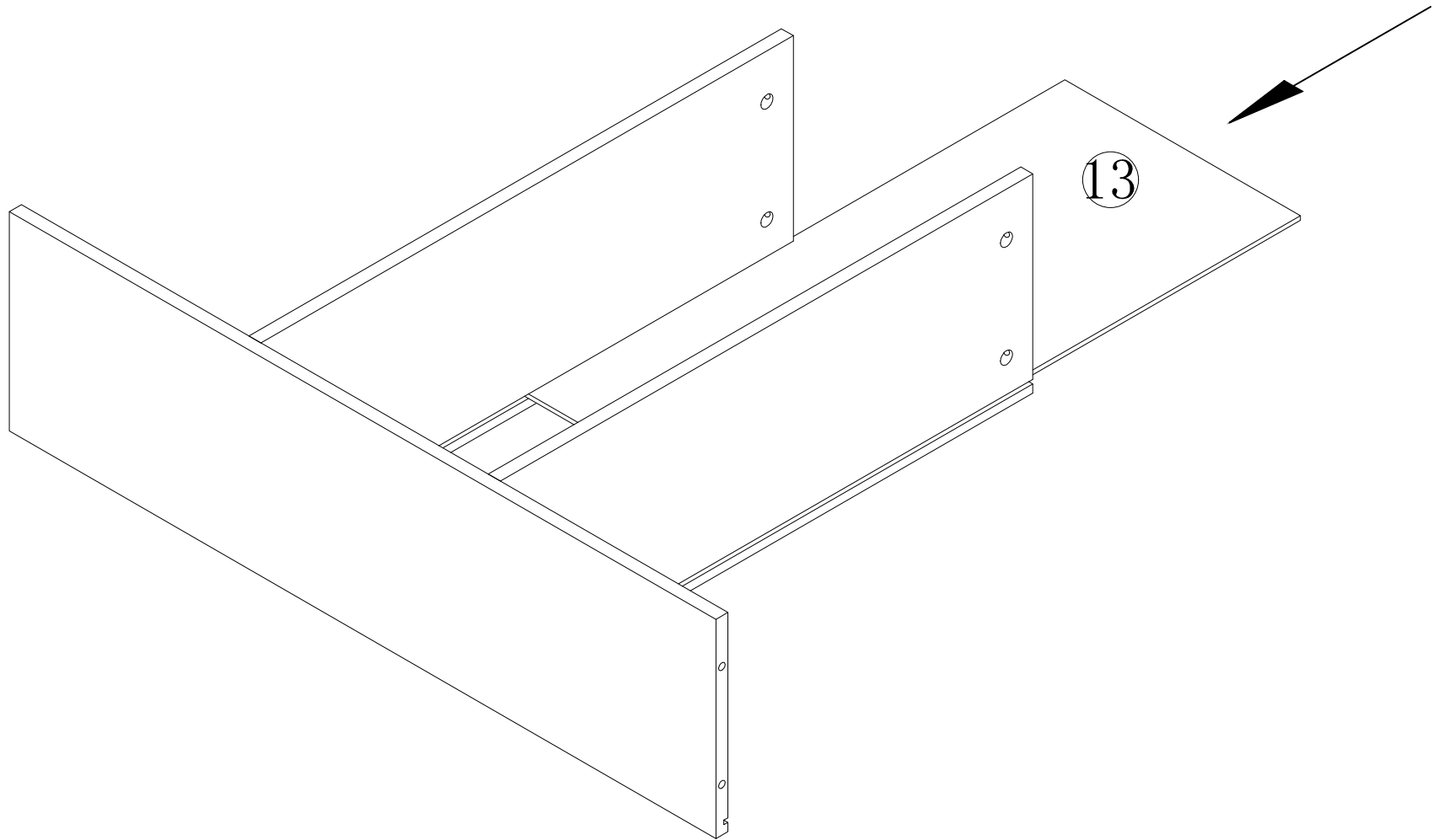

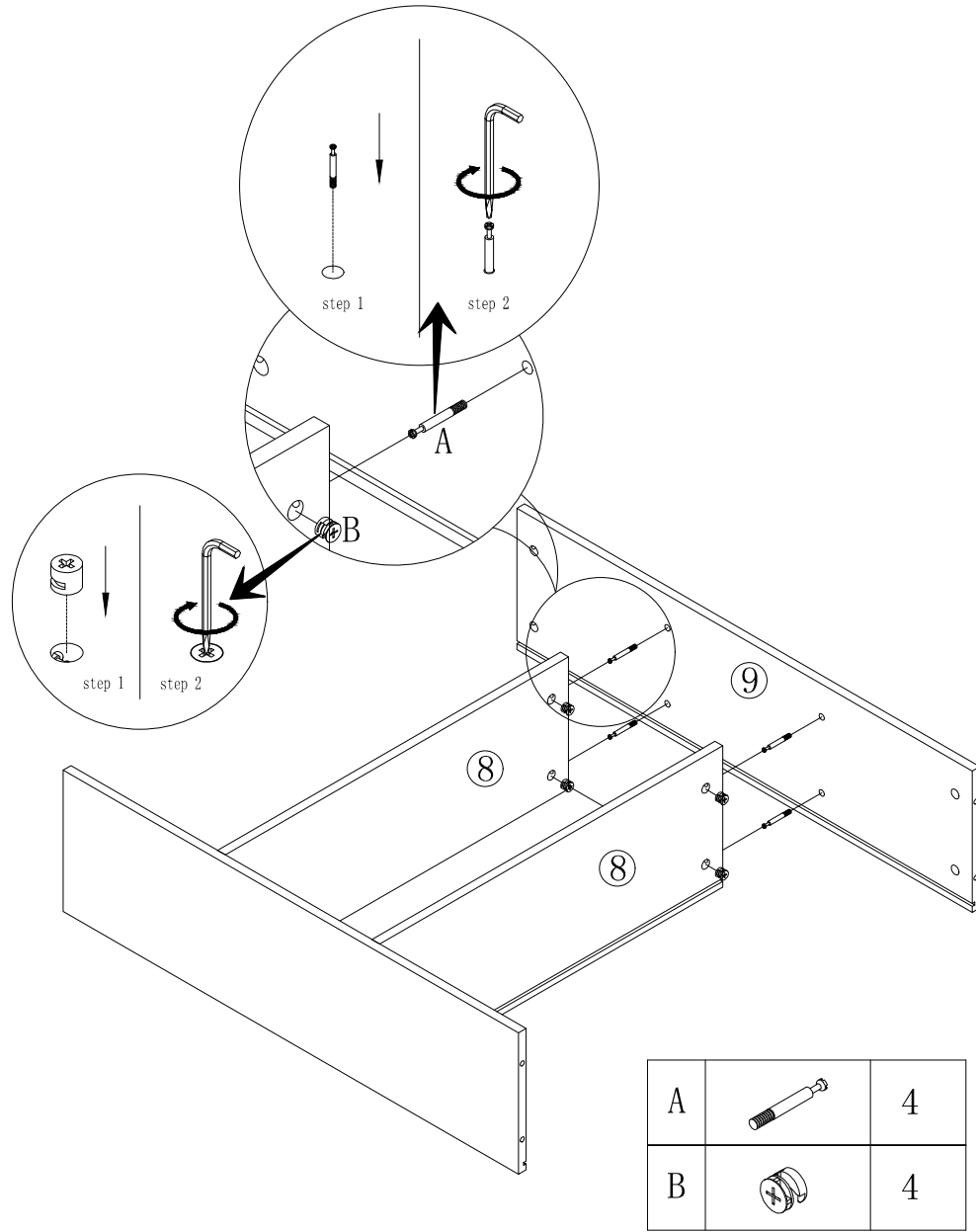

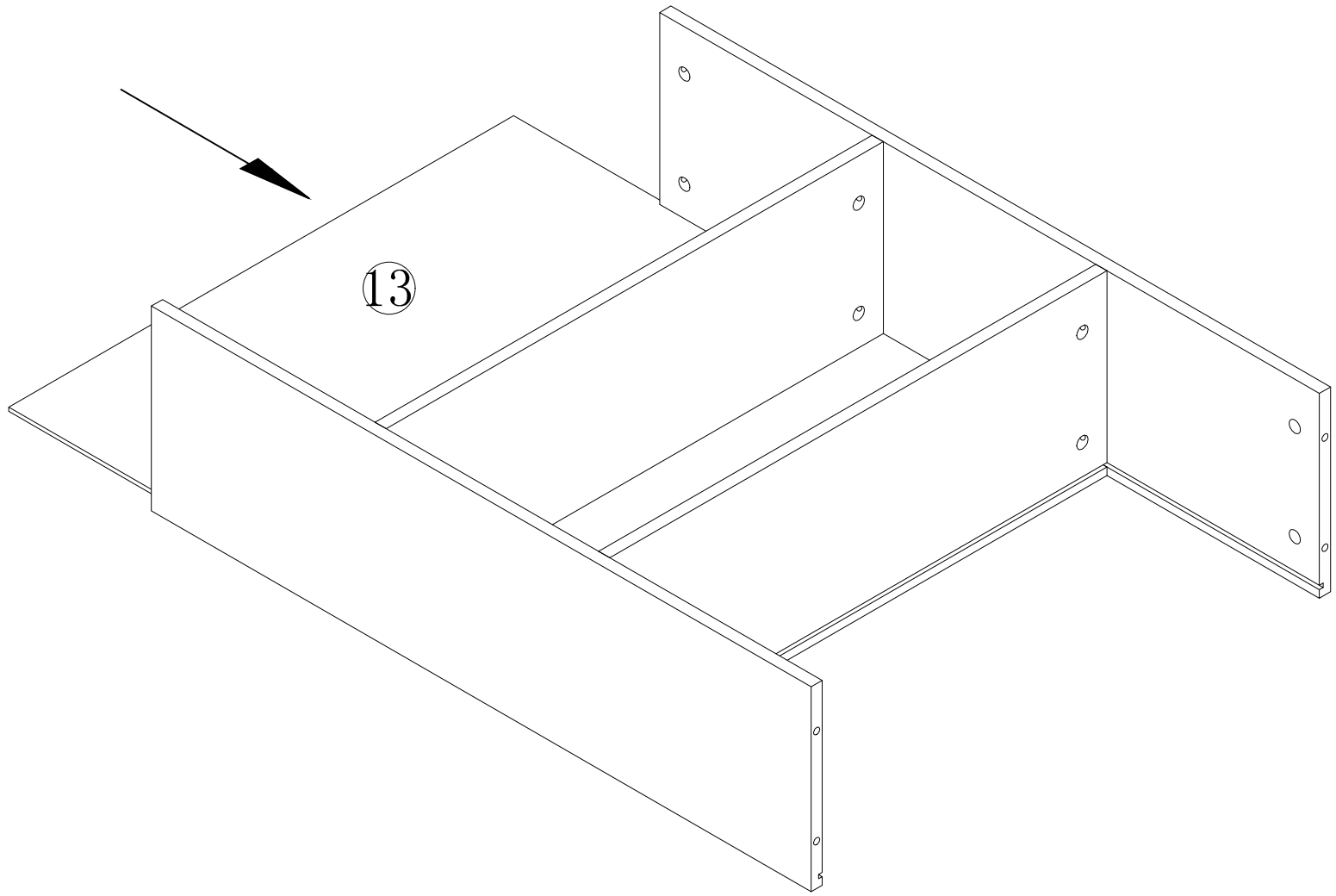

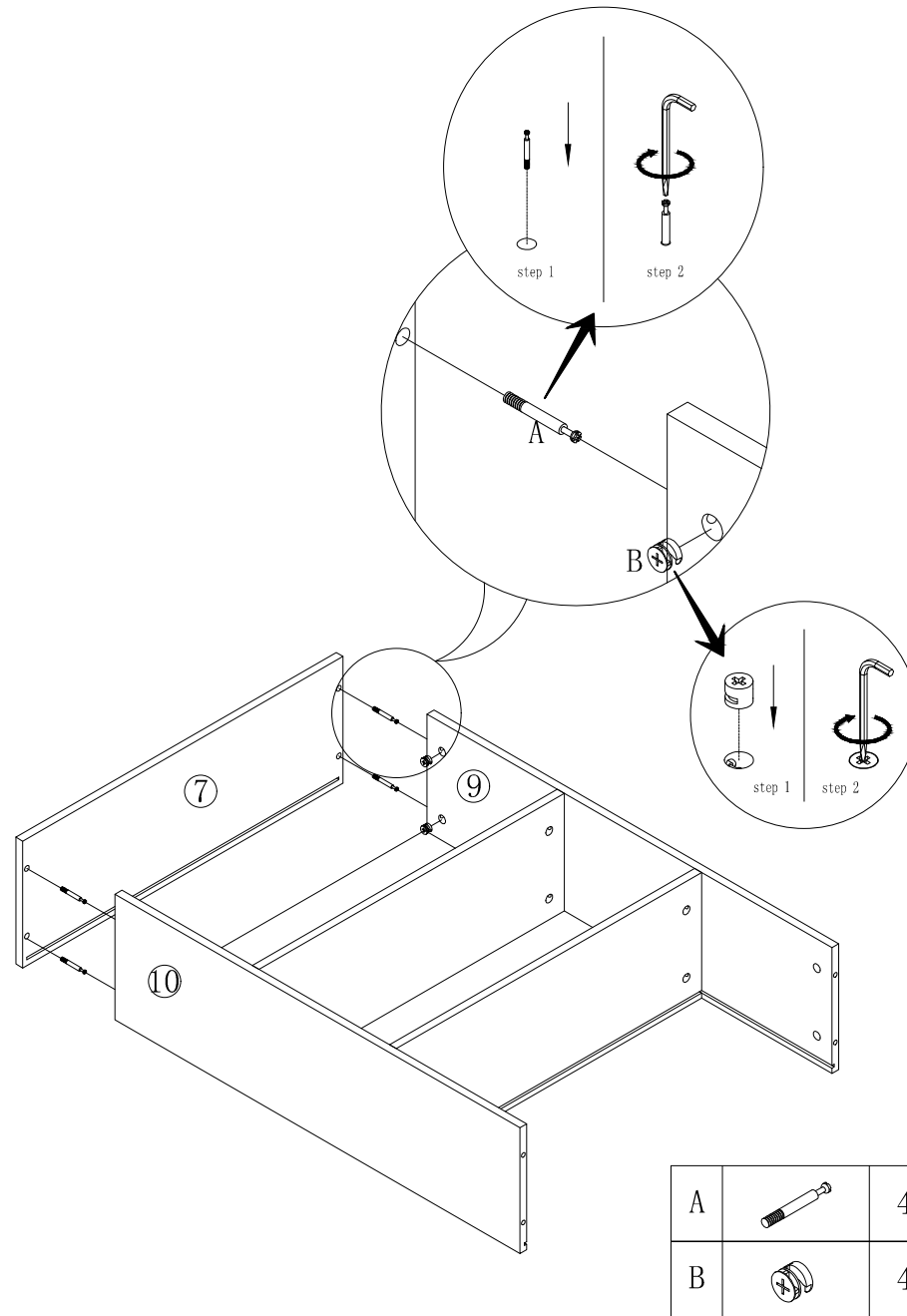

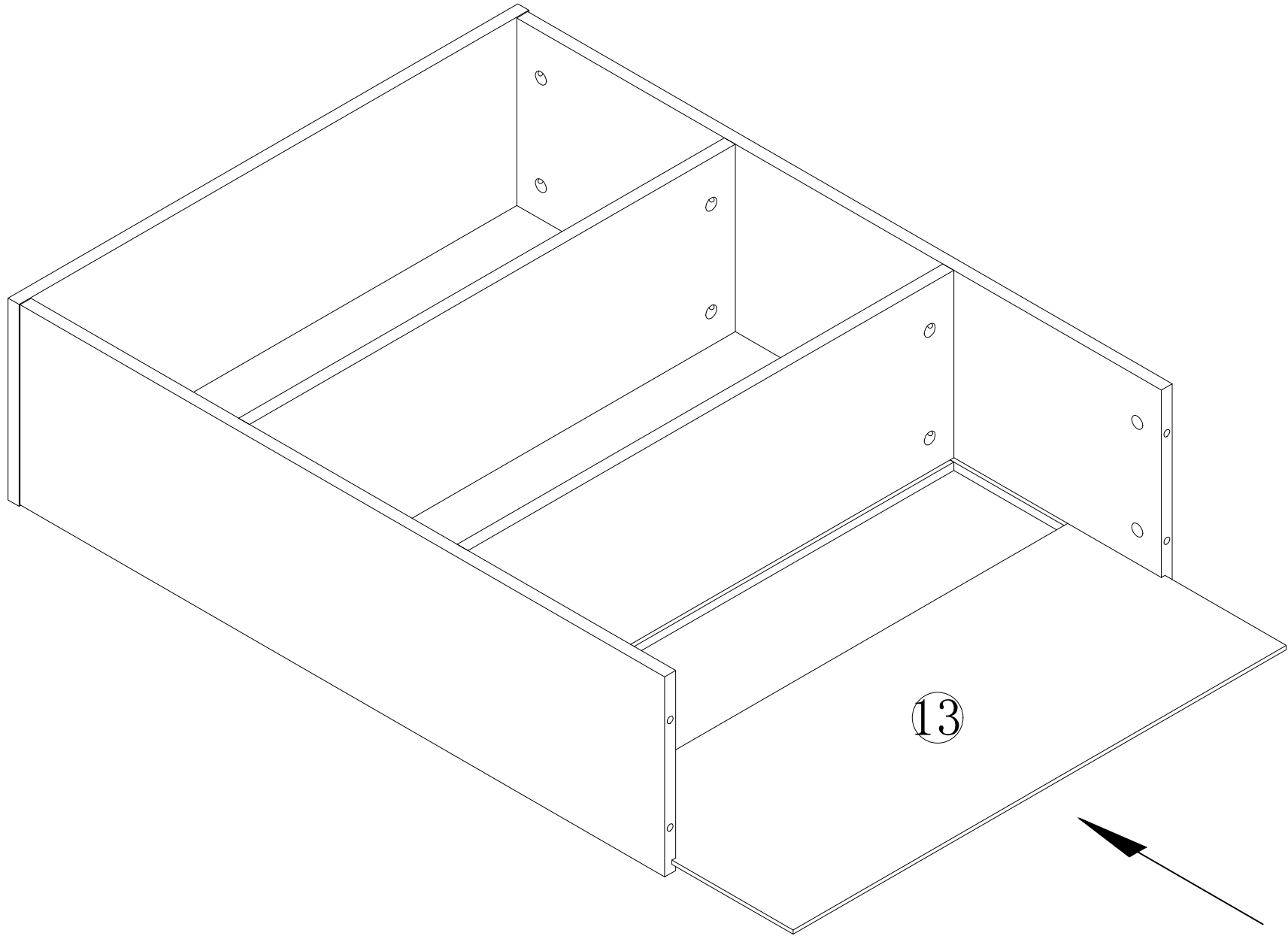

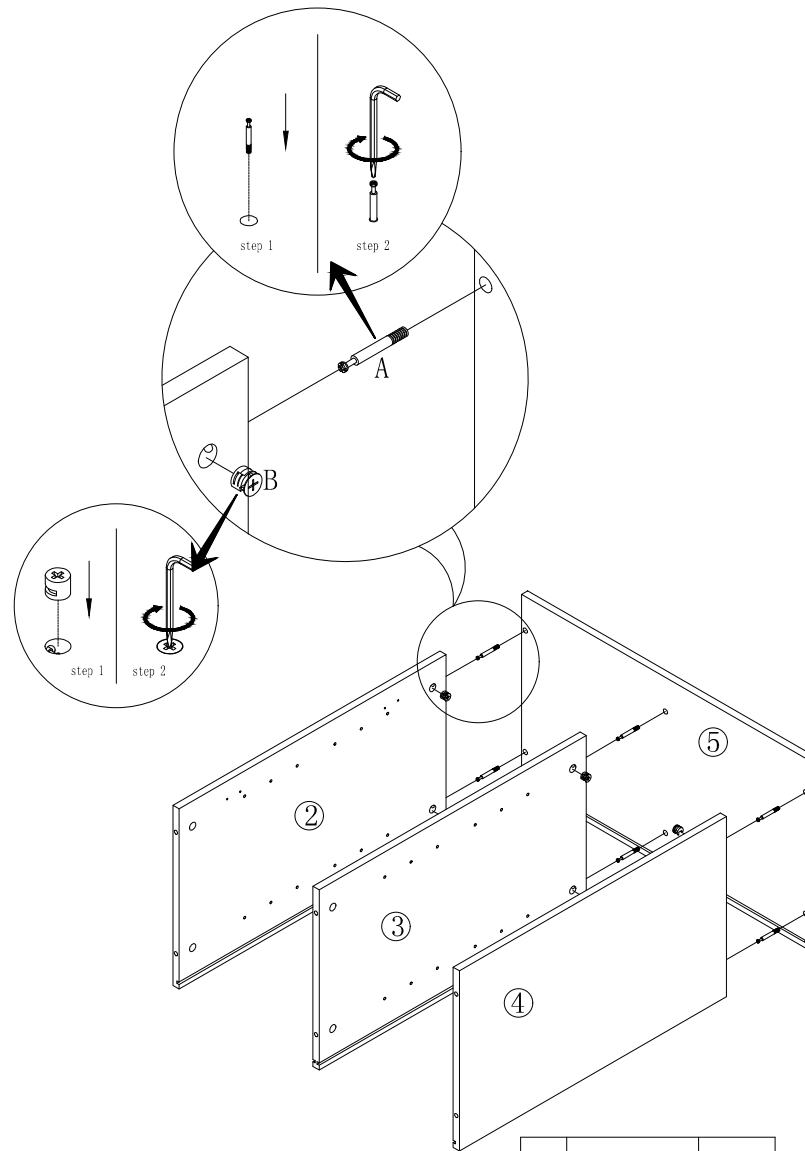





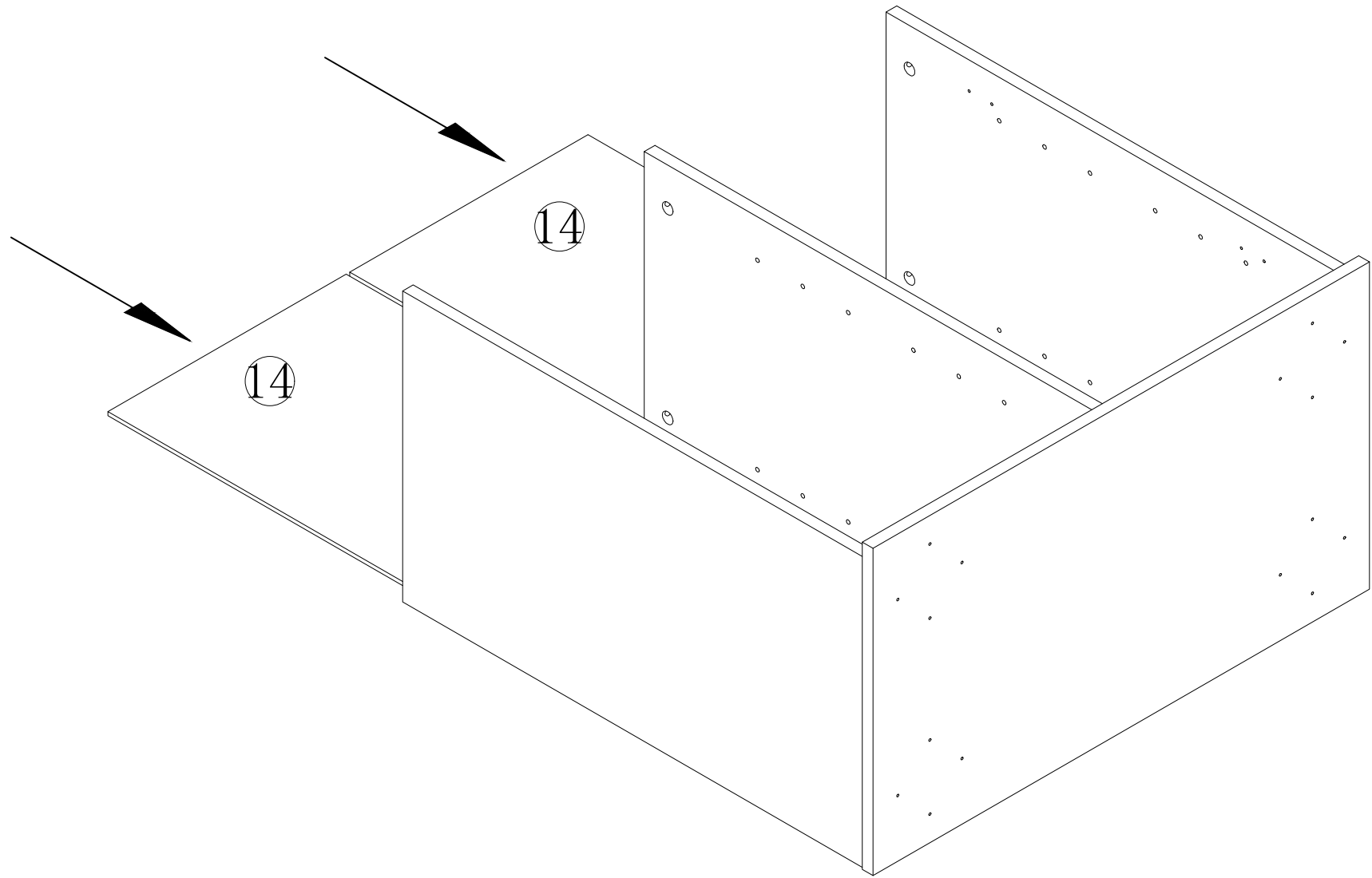

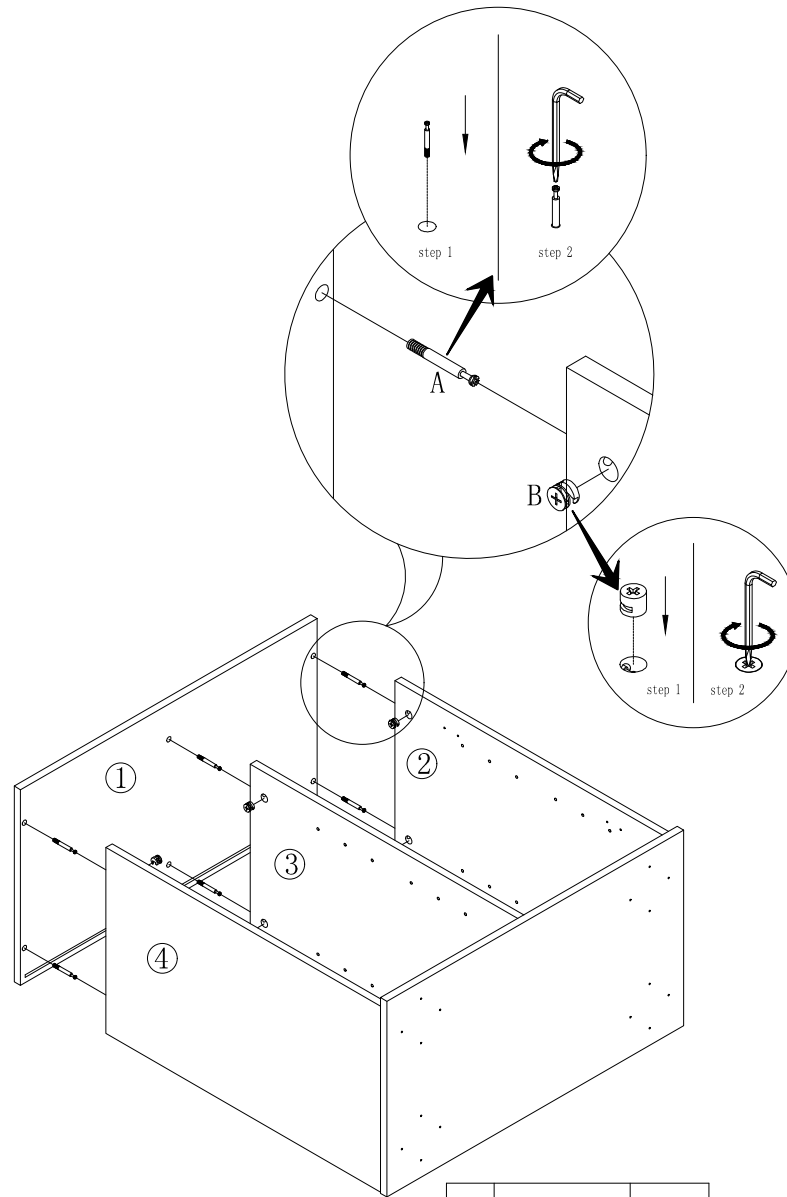
| | | |
|---|---|---|
| A |  | 6 |
| B |  | 6 |





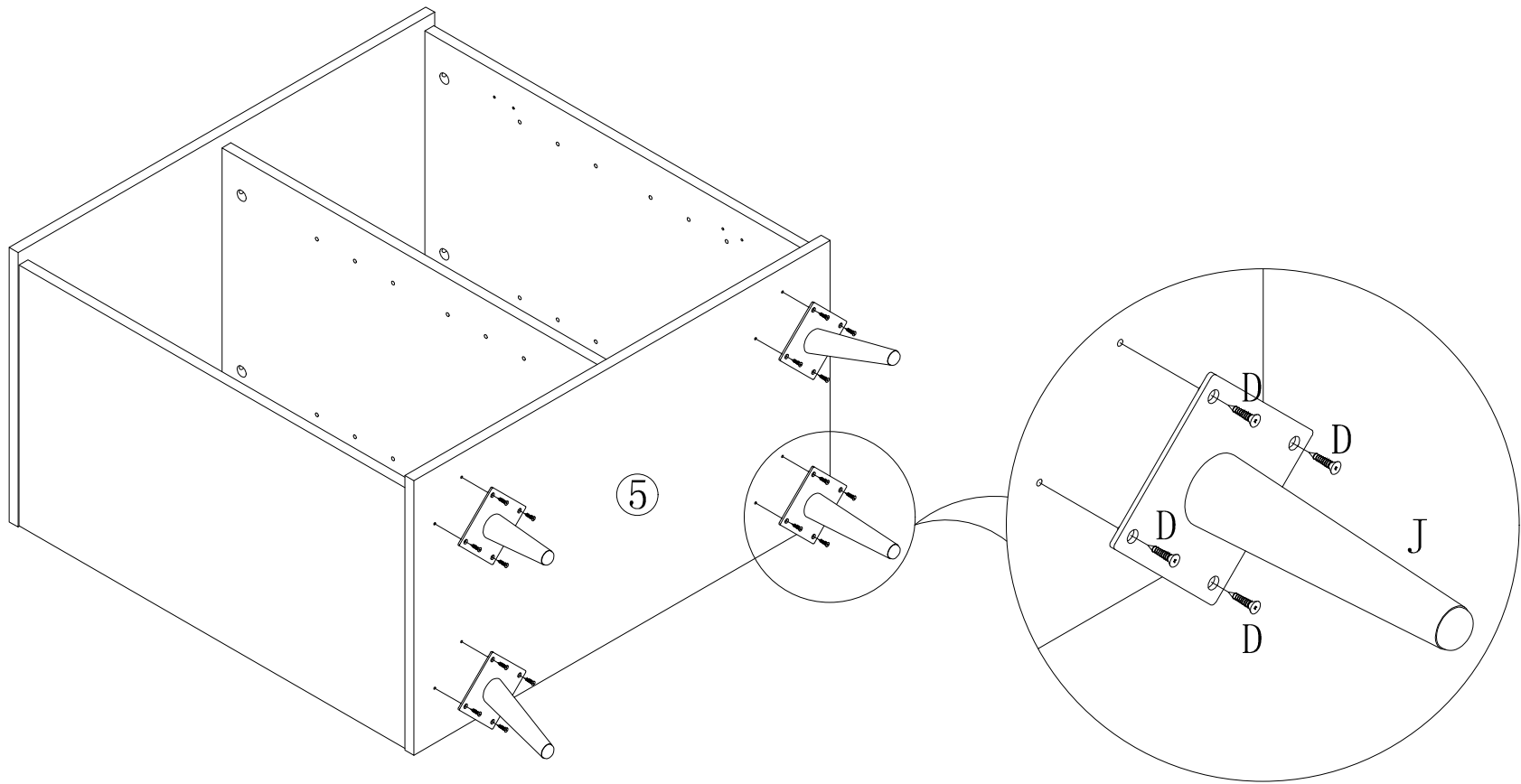

| | | |
|---|---|---|
| A |  | 6 |
| B |  | 6 |



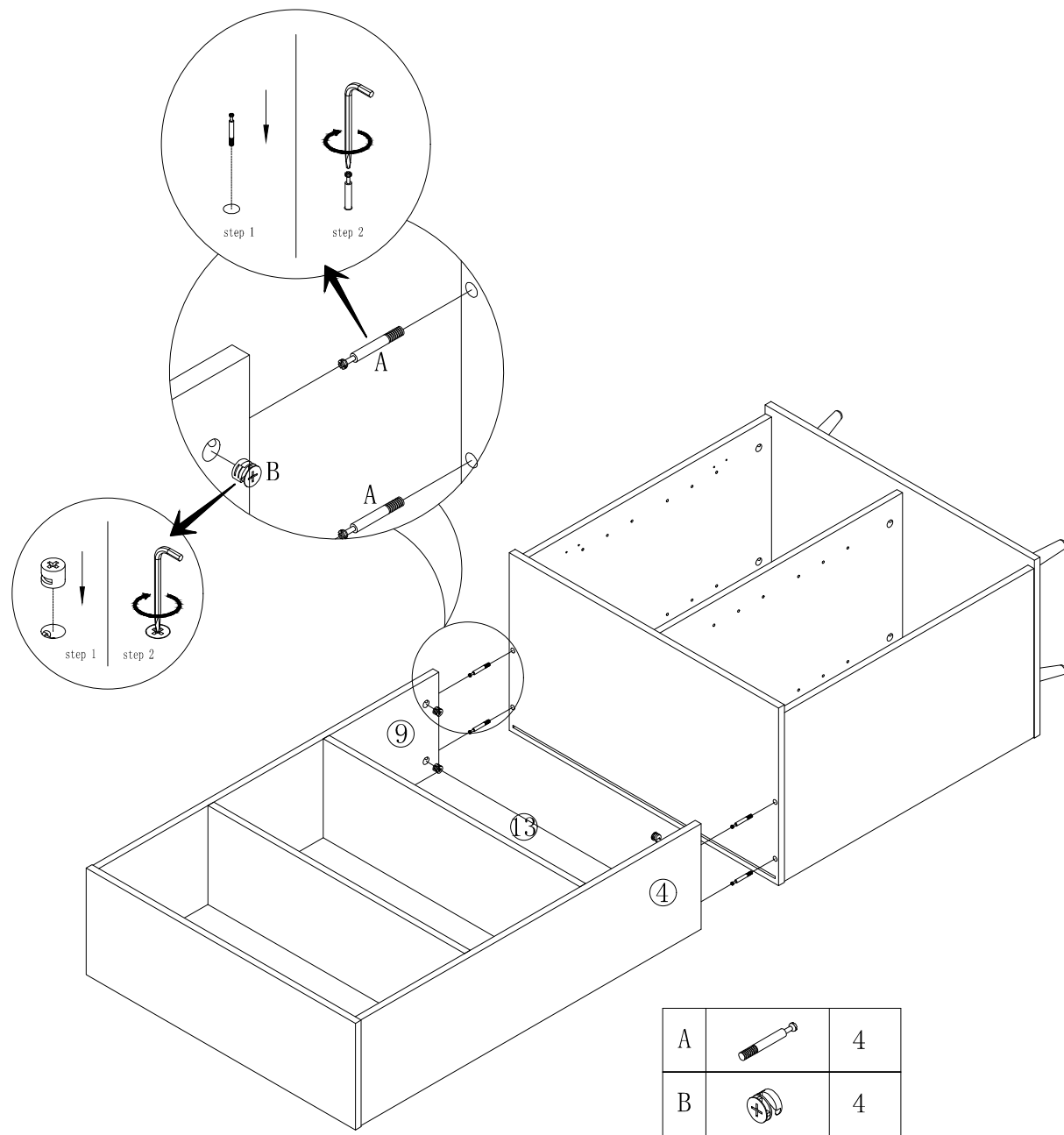

| | | |
|---|---|----|
| D |  3.5*14mm | 16 |
| J |  | 4 |



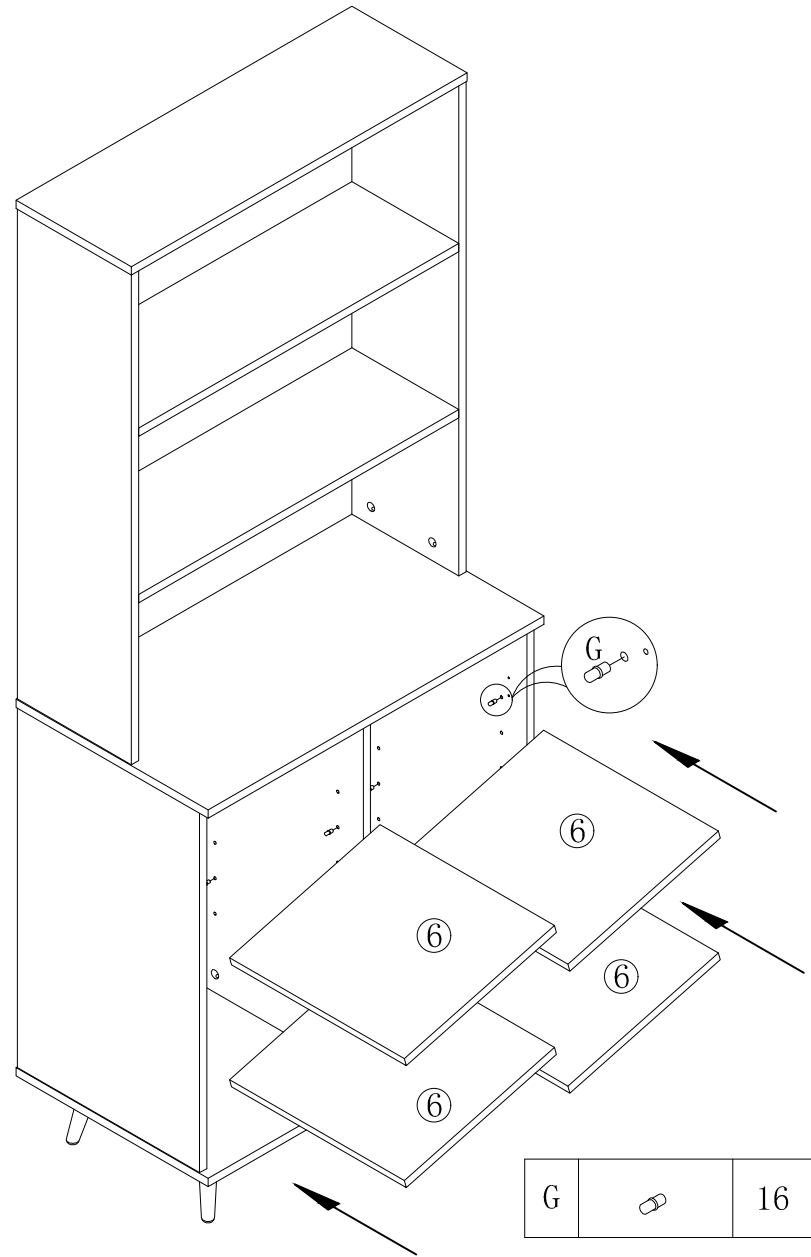

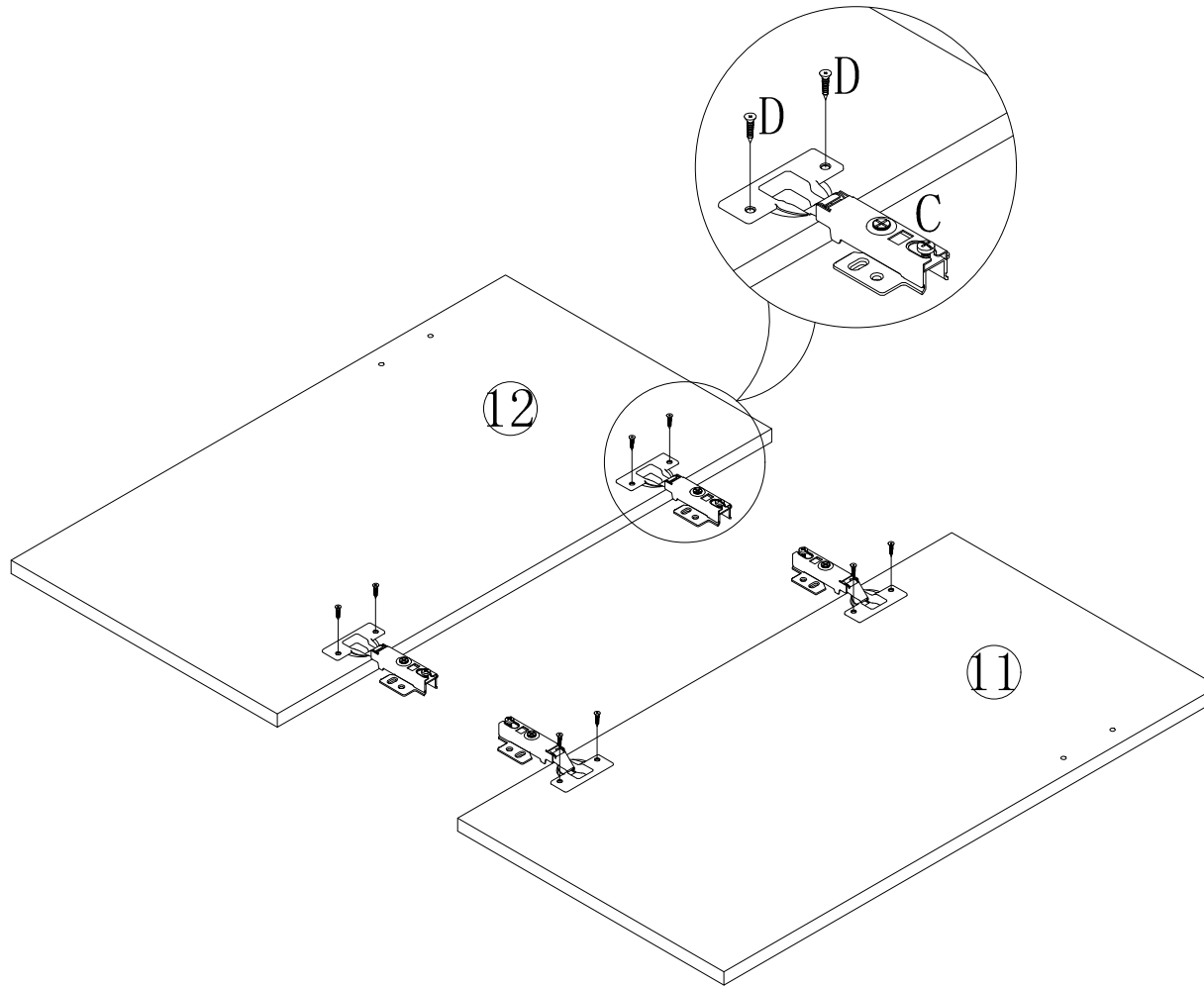

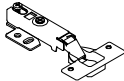
| | | |
|---|---|---|
| A |  | 4 |
| B |  | 4 |



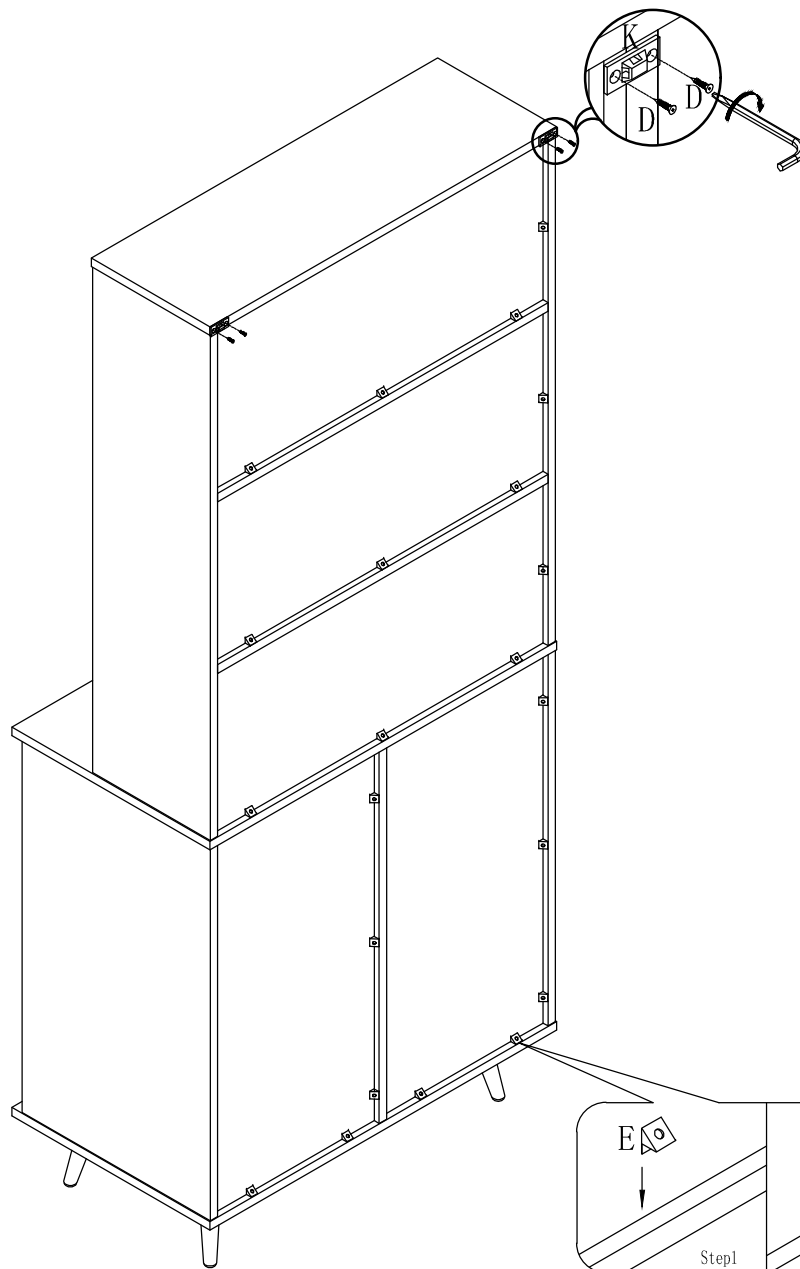





| | | |
|---|---|---|
| C |  | 4 |
| D |  3.5*14mm | 8 |

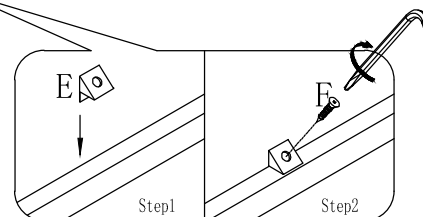

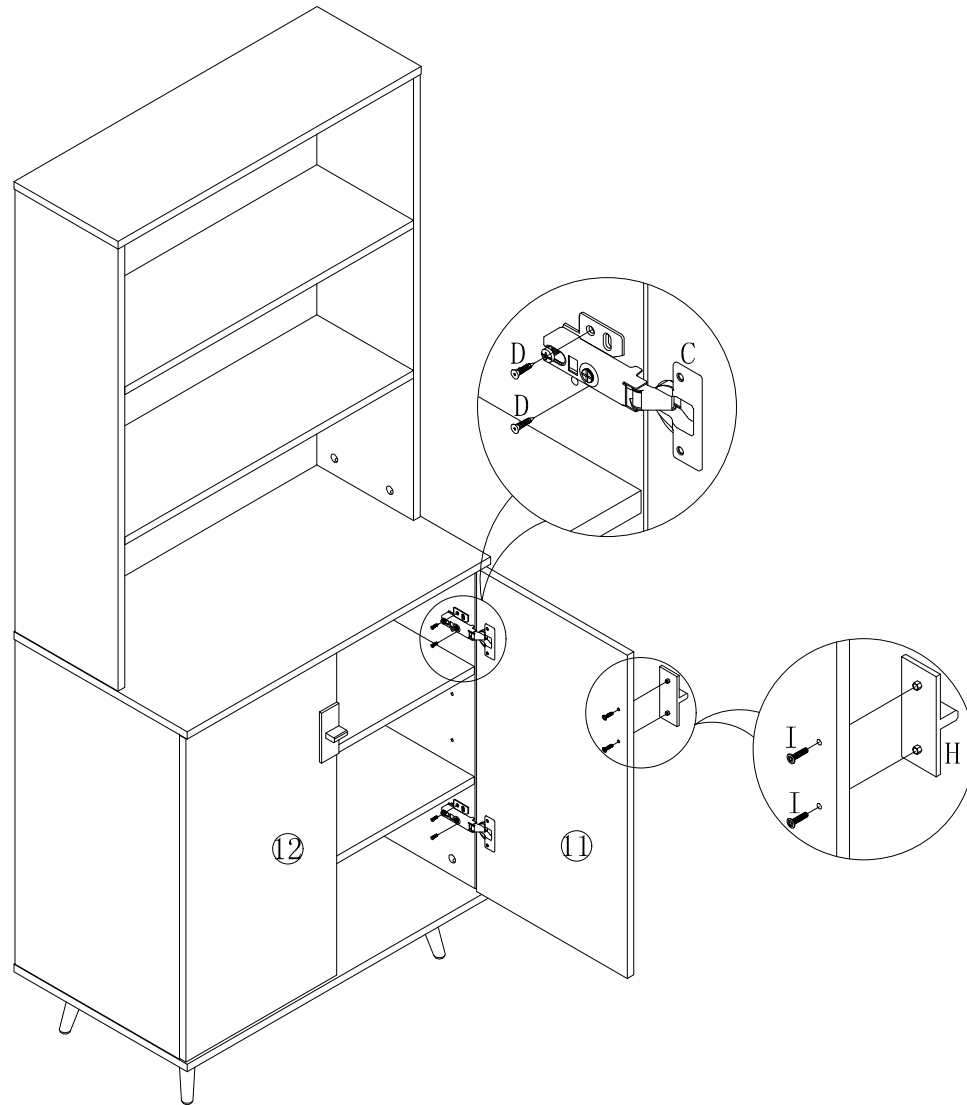
| | | |
|---|---|----|
| E |  | 44 |
| F |  3. 0*14mm | 44 |
| K |  3. 5*35mm 3. 5*14mm | 2 |
| D |  3. 5*14mm | 4 |





| | | |
|---|---|---|
| D |  3.5*14mm | 8 |
| H |  | 2 |
| I |  6*15mm | 4 |

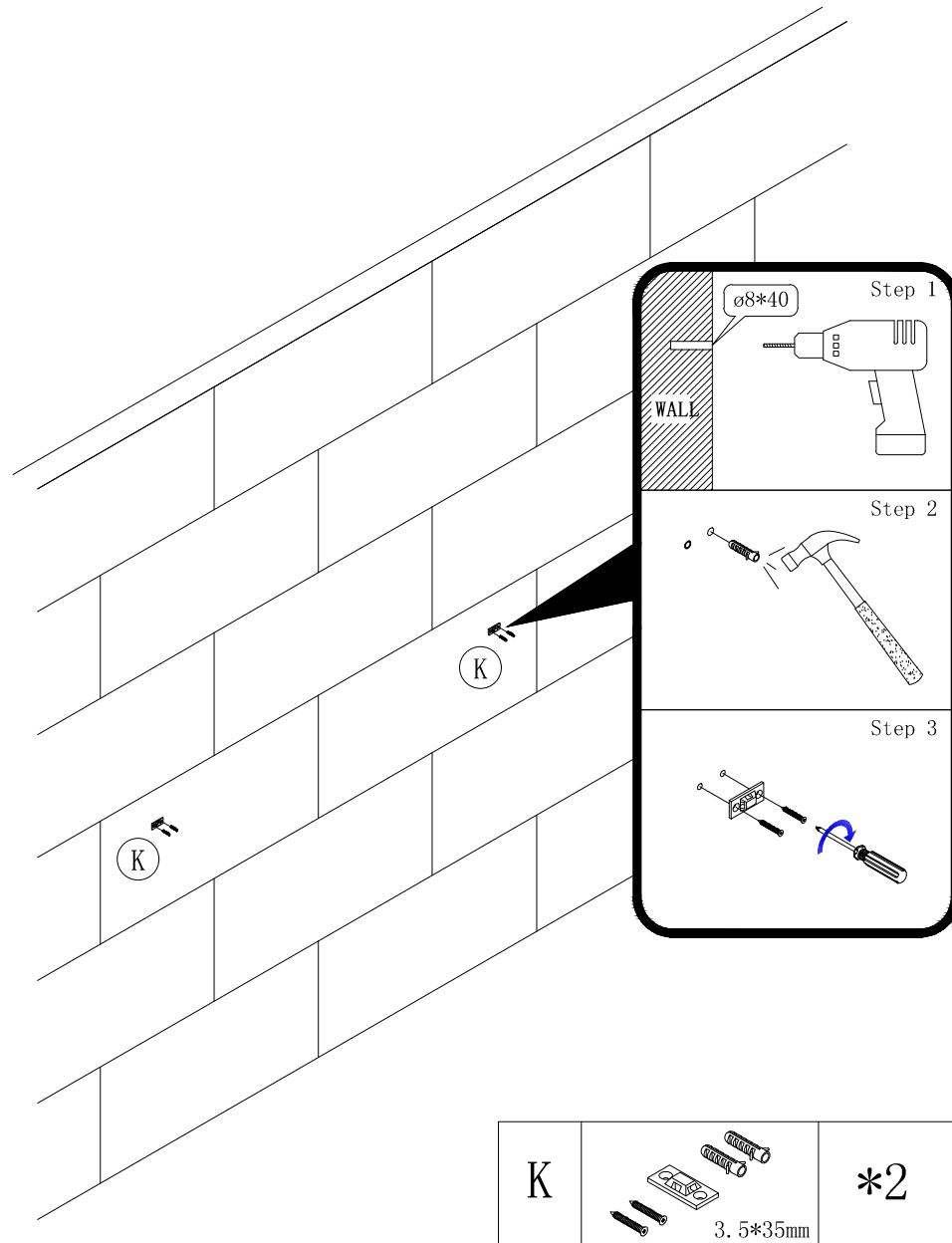

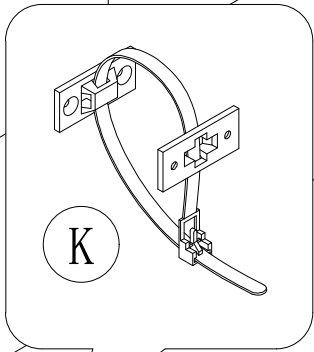
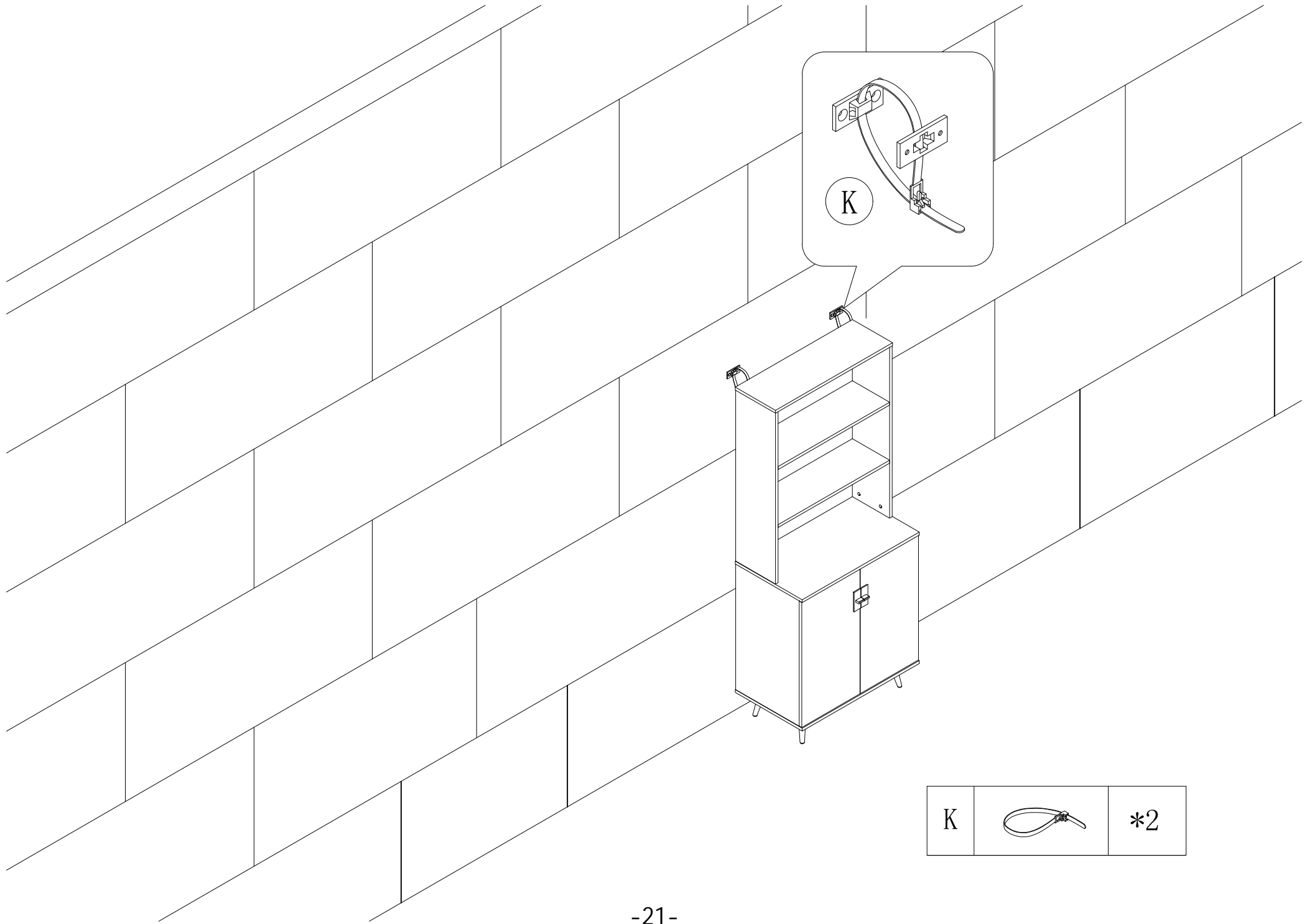

| | | |
|---|---|----|
| K |  | *2 |
|---|---|----|