







































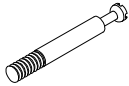

Parts List

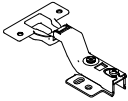
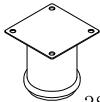
NO.	Drawing	Dimension	QTY
1		890*390*15mm	1
2		890*390*15mm	1
3		839*362*15mm	1
4		839*362*15mm	1
5		415*288*15mm	1
6		400*362*15mm	1
7		160*347*30mm	1
8		400*362*15mm	1
9		415*288*15mm	1
10		839*362*15mm	1
11		839*50*15mm	1
12		839*50*15mm	1
13		839*50*15mm	1
14		417*395*15mm	1
15		417*395*15mm	1

NO.	Drawing	Dimension	QTY
16		417*200*15mm	1
17		417*200*15mm	1
18		300*96*15mm	2
19		300*96*15mm	2
20		350*96*15mm	2
21		360*294*4mm	2
22		413*205*4mm	4
23		L404mm	2
24		849*170*4mm	1
25		849*235*4mm	1
26		402*346*15mm	2
27		495*46*46mm	1
28		495*46*46mm	1
29		495*46*46mm	1
30		495*46*46mm	1

Hardware Fitting

NO.	Drawing	QTY
A		54
B		54
C	 8*60mm	1
D		28
E	 3.0*14mm	28
F		4
G	 38*80mm	2

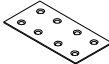
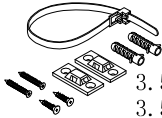
NO.	Drawing	QTY
H	 3.5*14mm	52
I		4
J		8
K		8
L	 6*25mm	4
M		1
N		1
O	 3.5*35mm 3.5*14mm	2

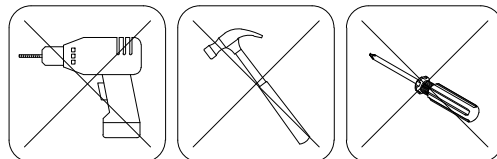

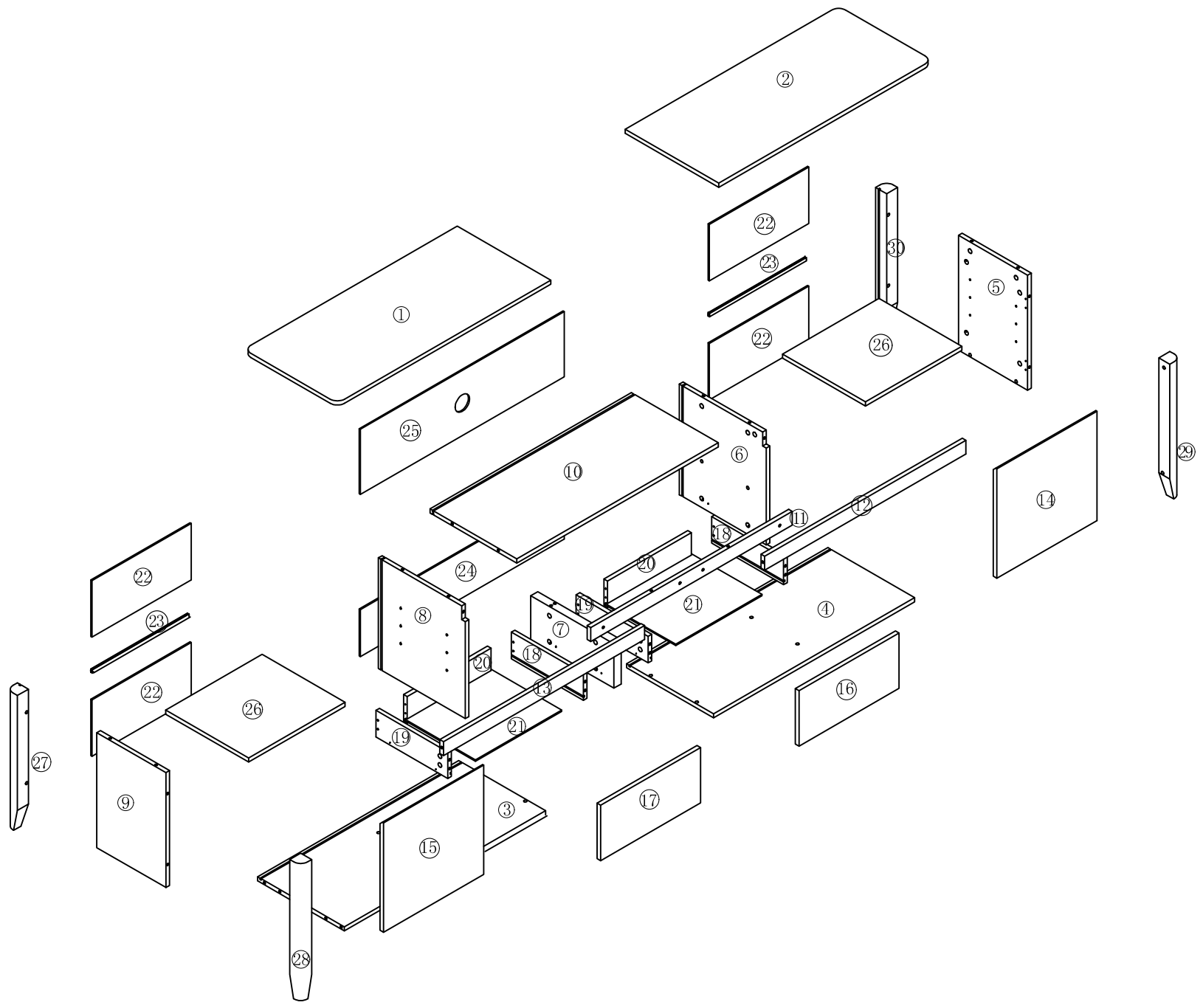

Cam Coupling Using Methods

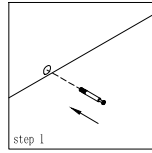

Step1.

Connect the cam coupling A as directed in the assembly instructions using hand.

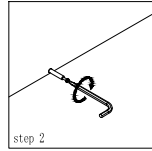

Step2.

Screw the cam coupling A as directed in the assembly instructions.

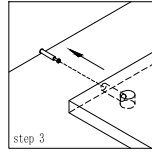

Step3.

Push the cam coupling A into the entry hole.

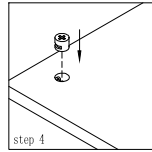

Step4.

Insert the cam coupling B as shown in the instructions.

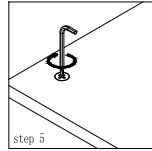

Step5.

Turn the cam coupling B clockwise with a screwdriver

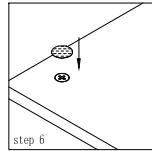

Step6.

Put on Beautycam.

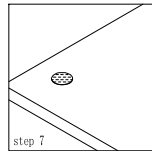



Step7.

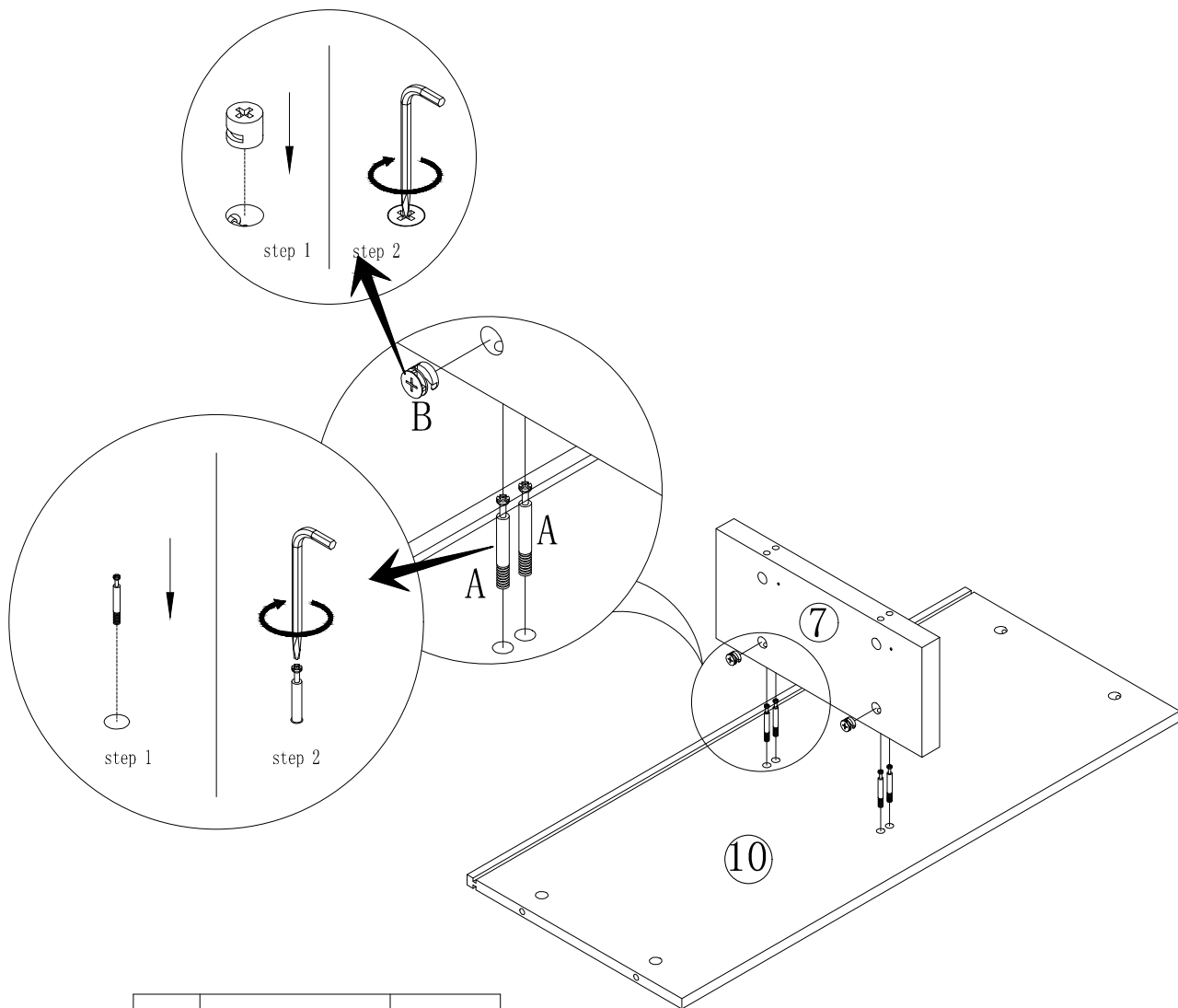

Finished.

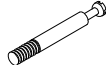
You should feel a click when the camlock is locked in place.
The joint is now secure.

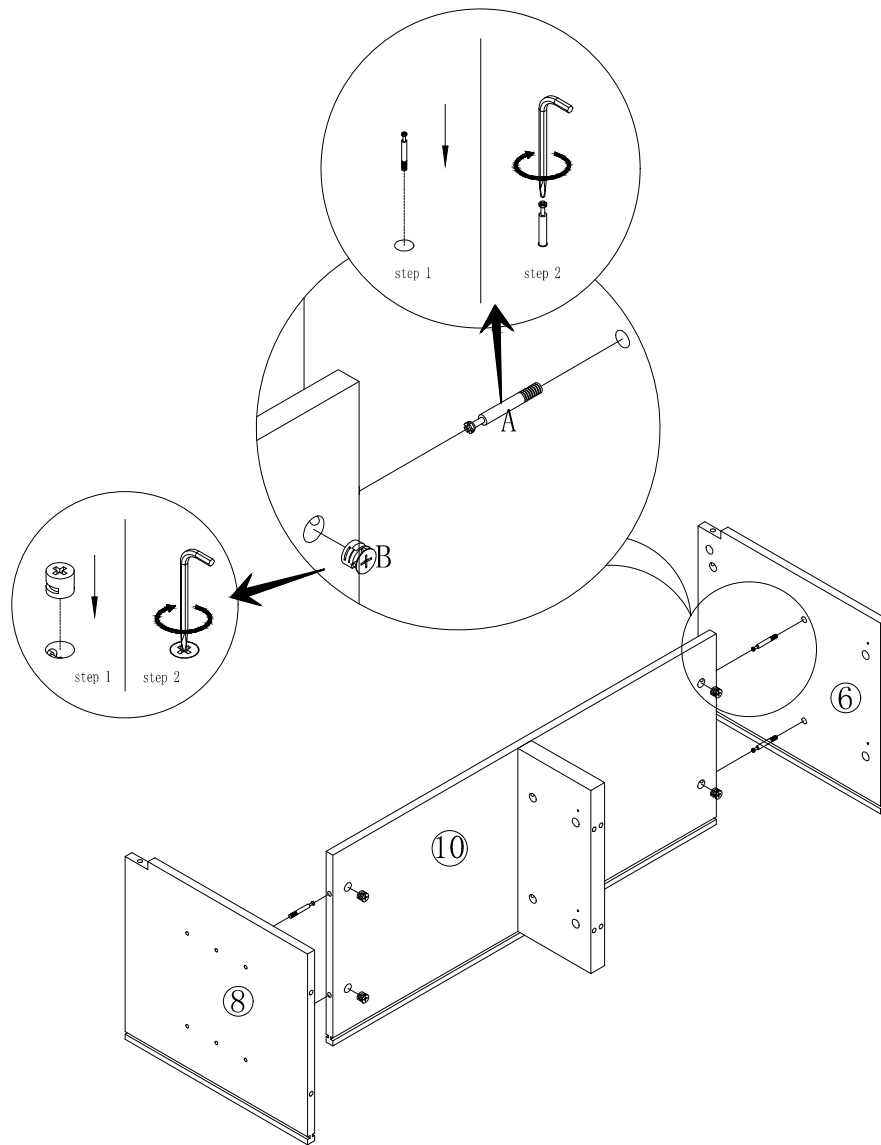

A		4
B		4



A		4
B		4

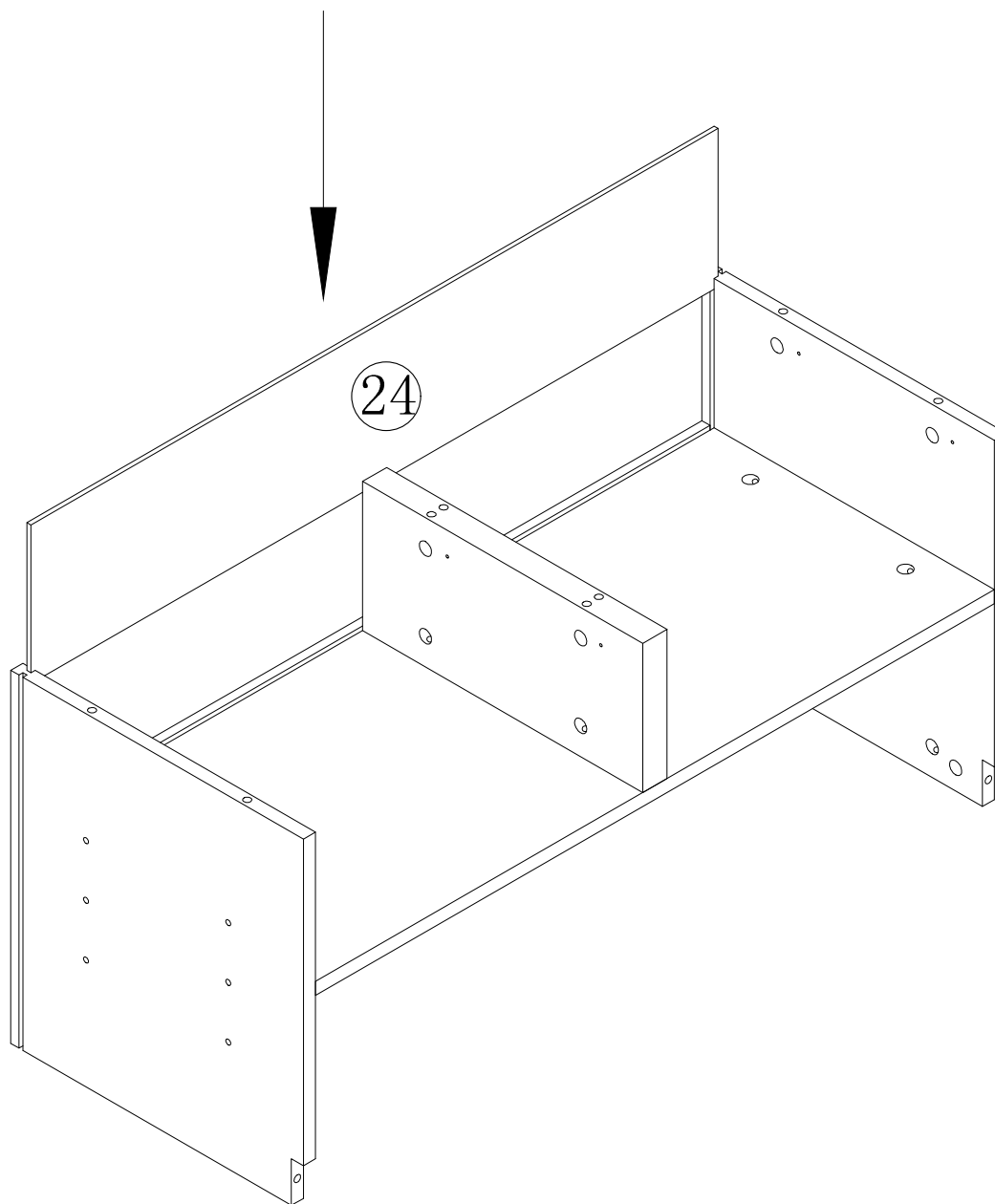

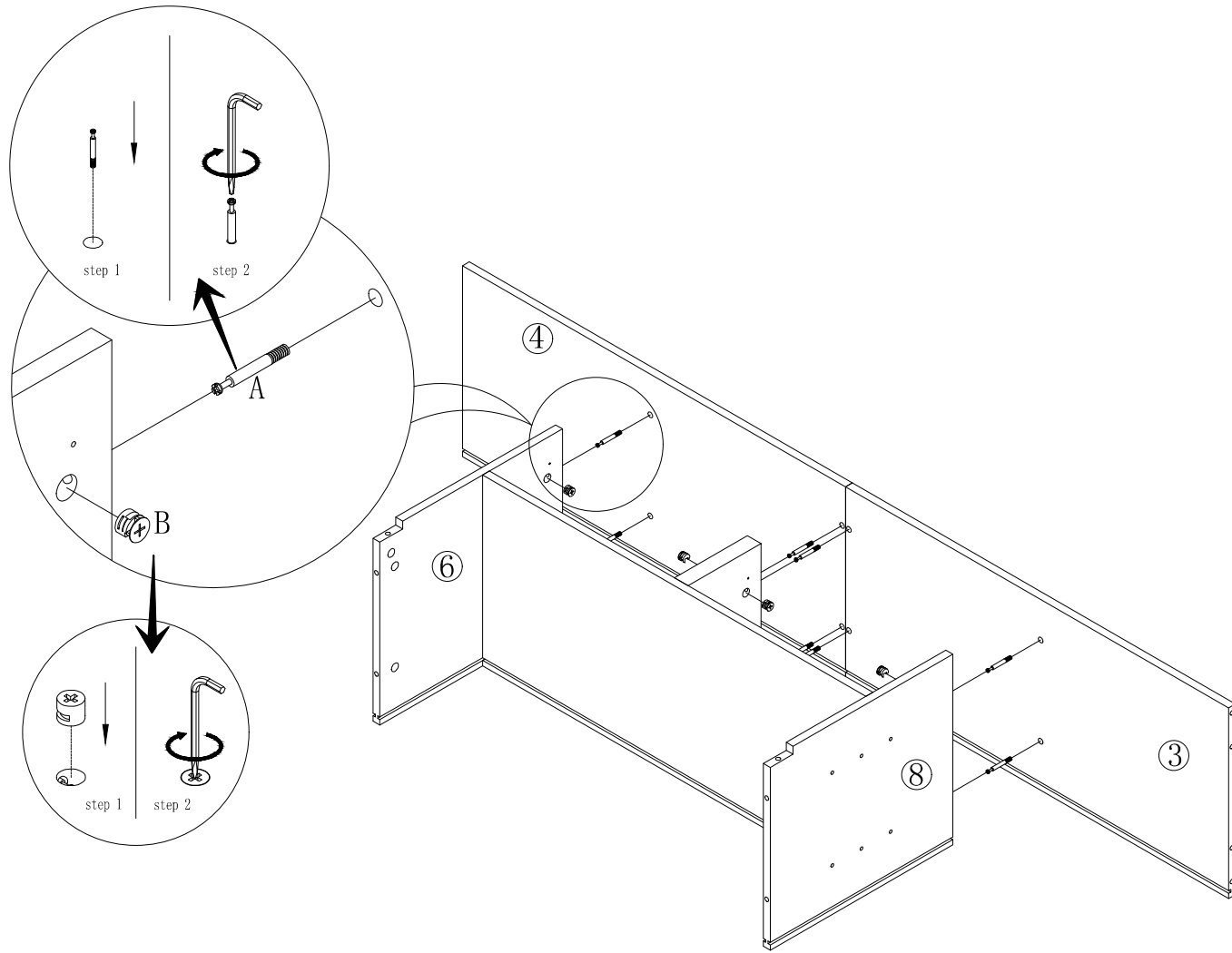



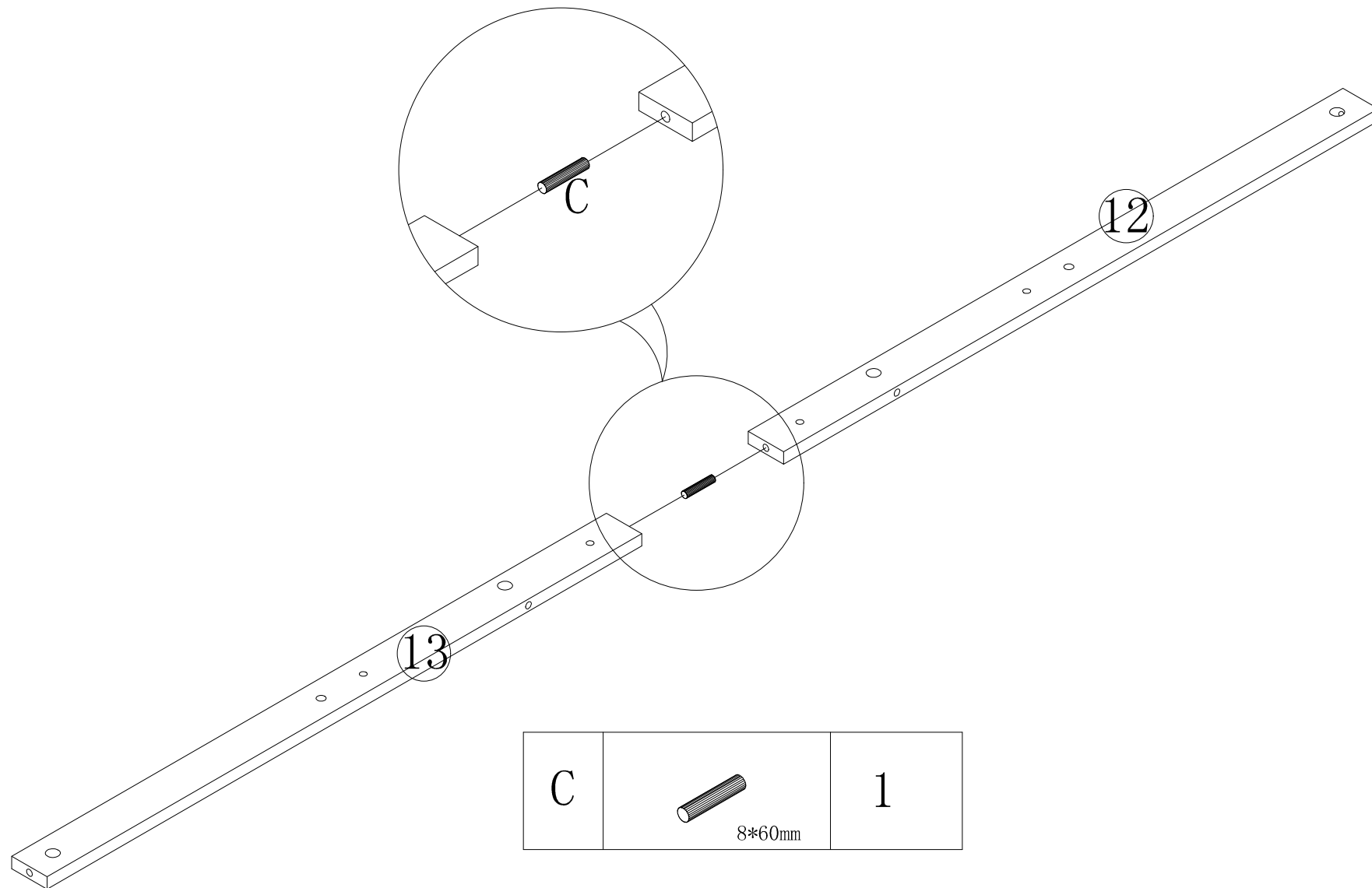

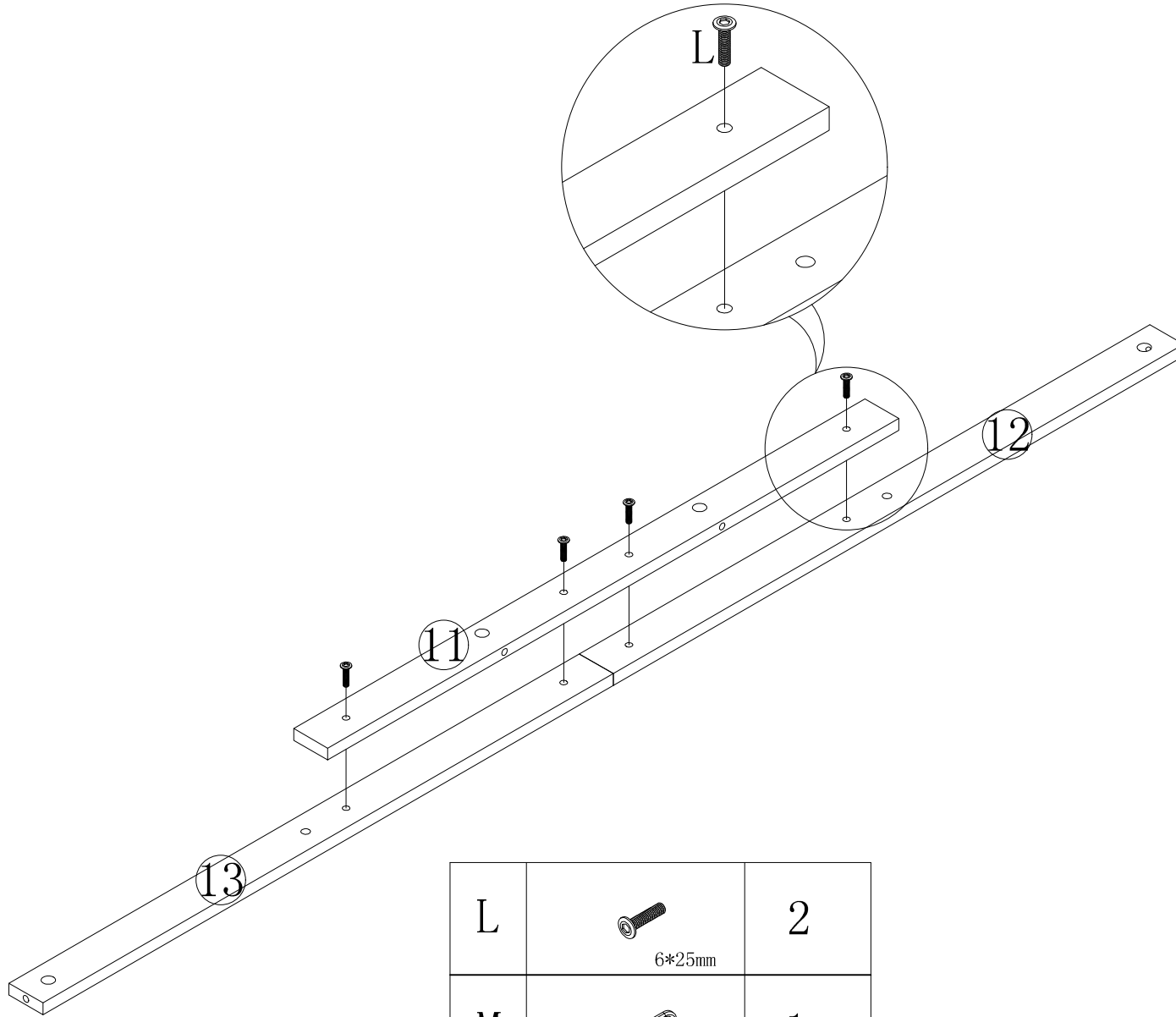
A		8
B		8





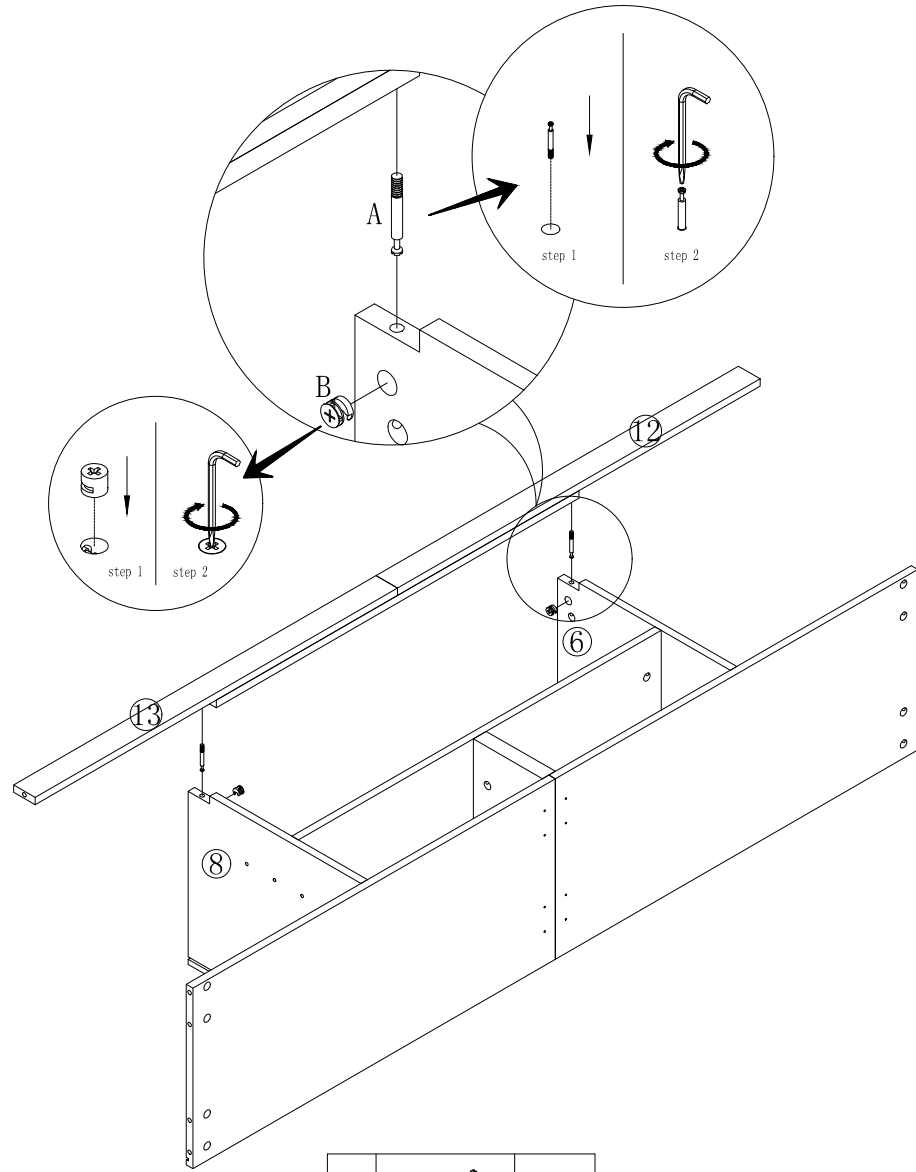

L	 6*25mm	2
M		1



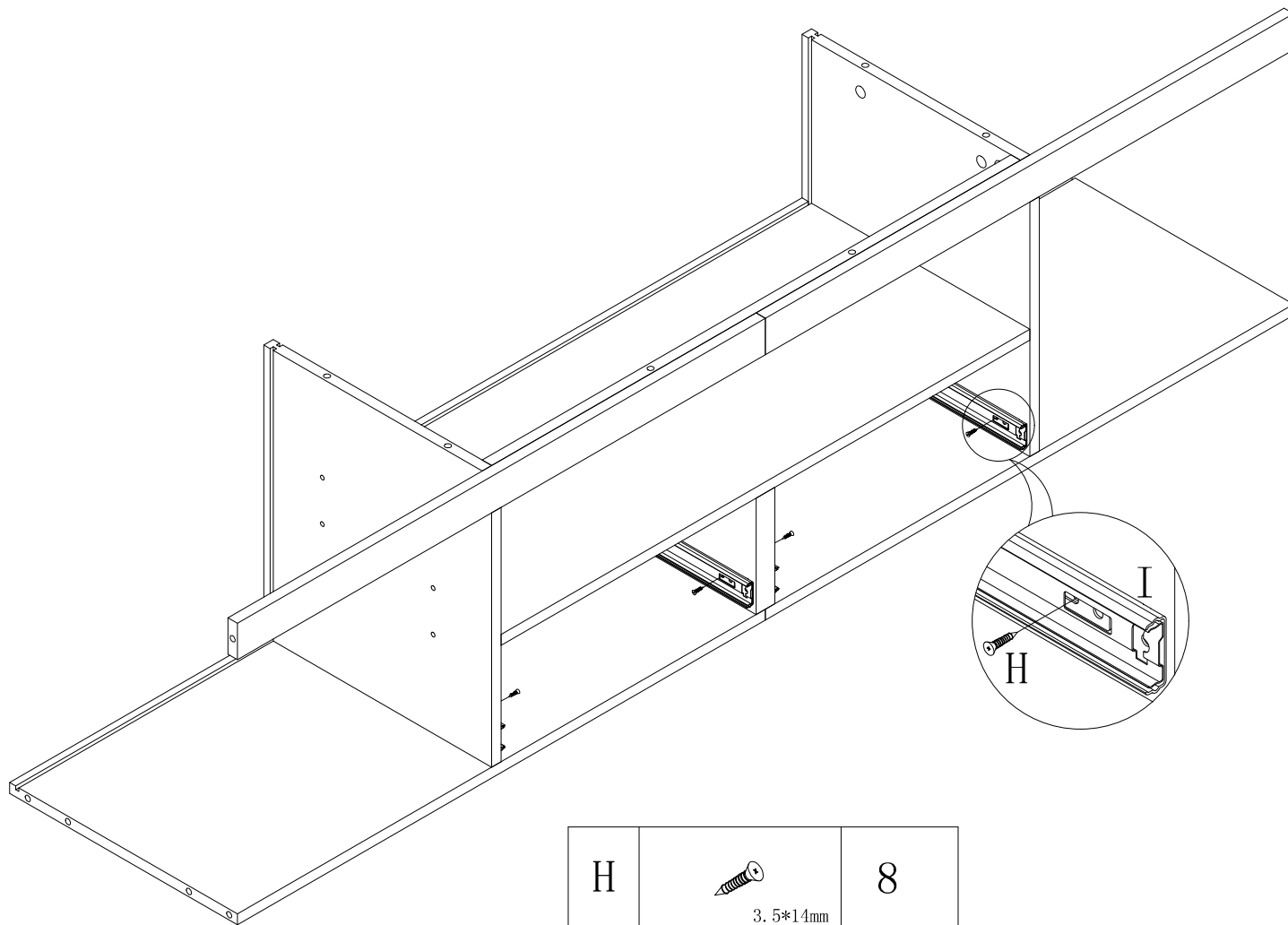

A		2
B		2



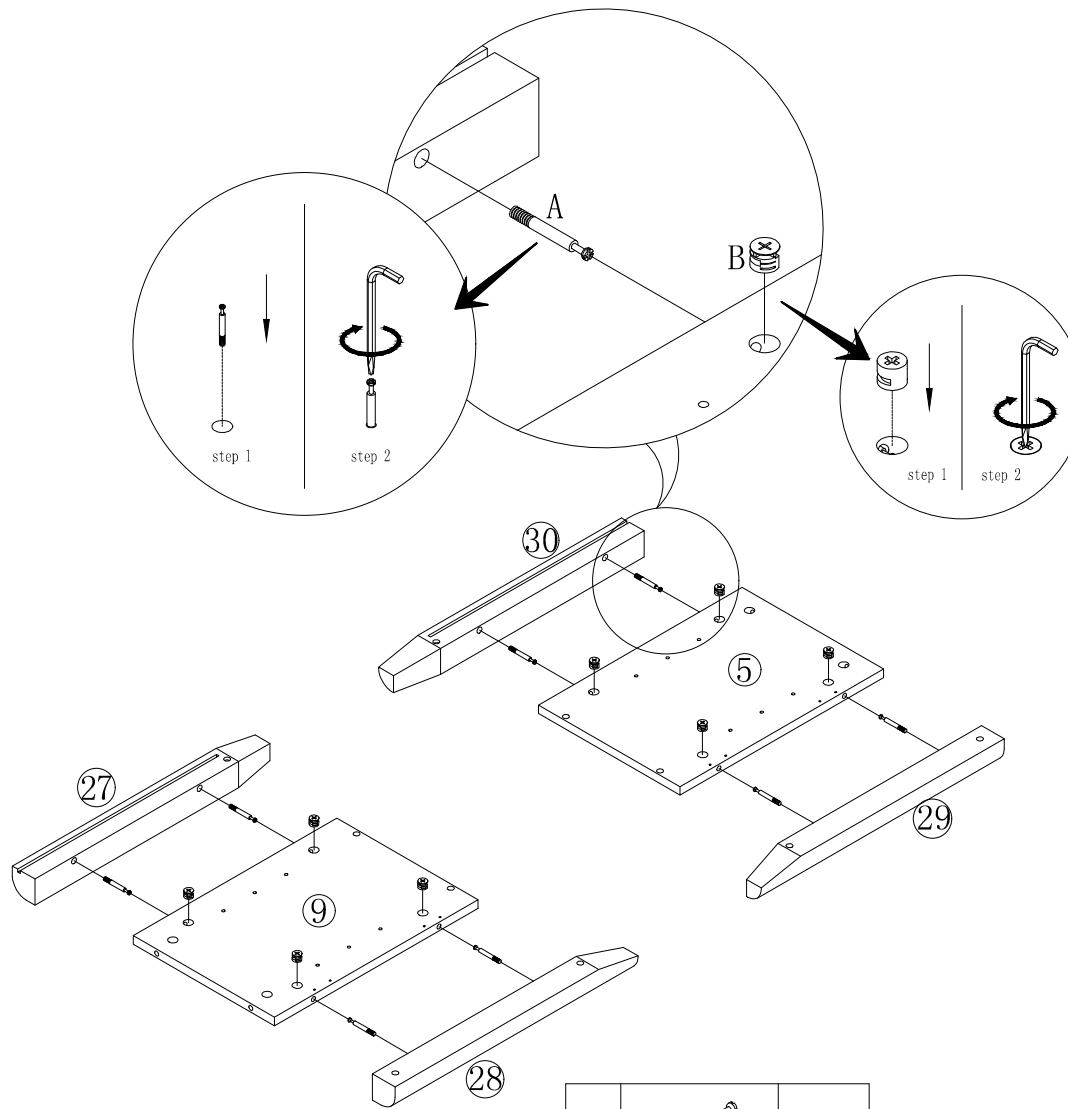

H	 3.5*14mm	8
I		4

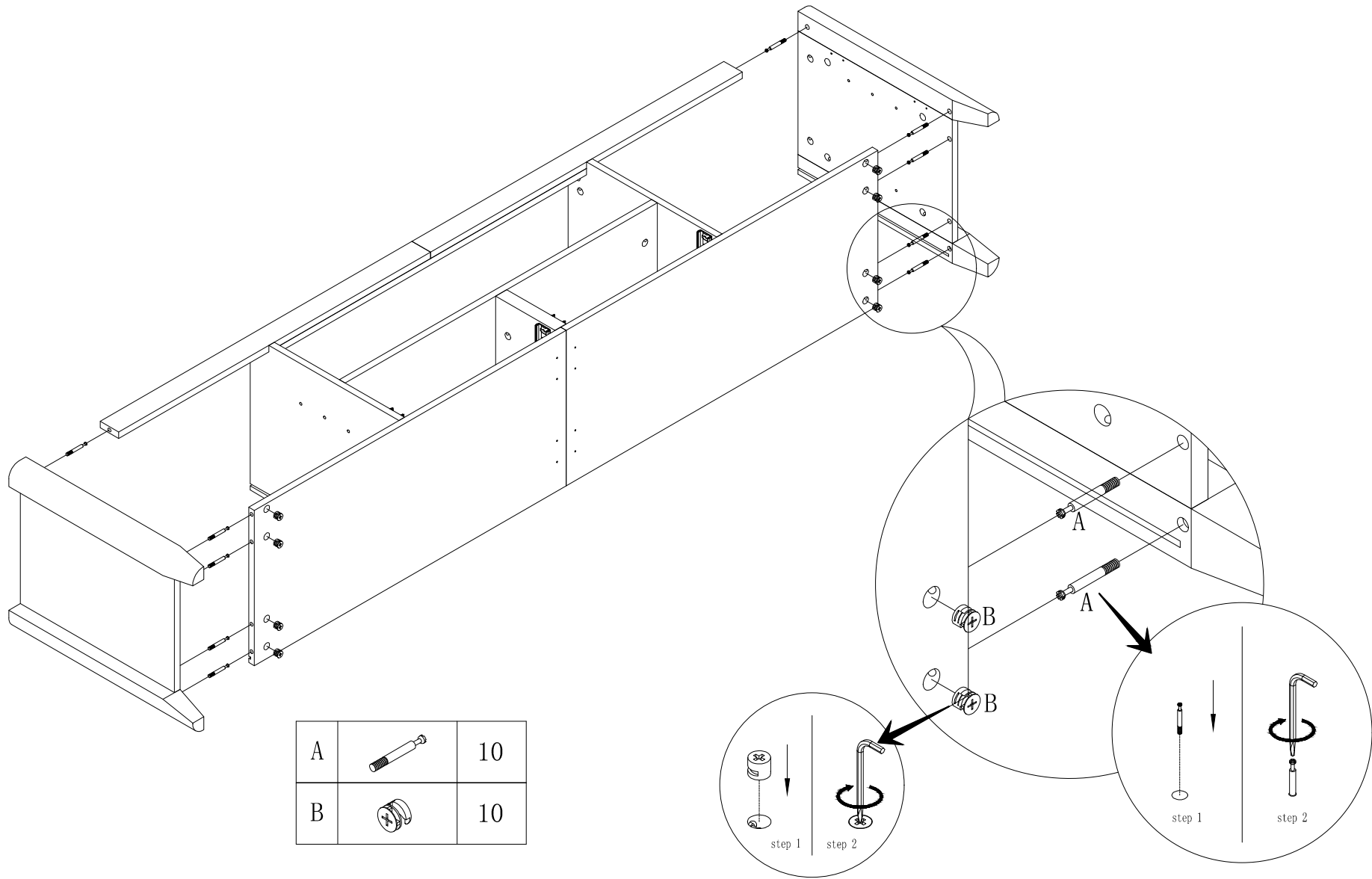

A		8
B		8

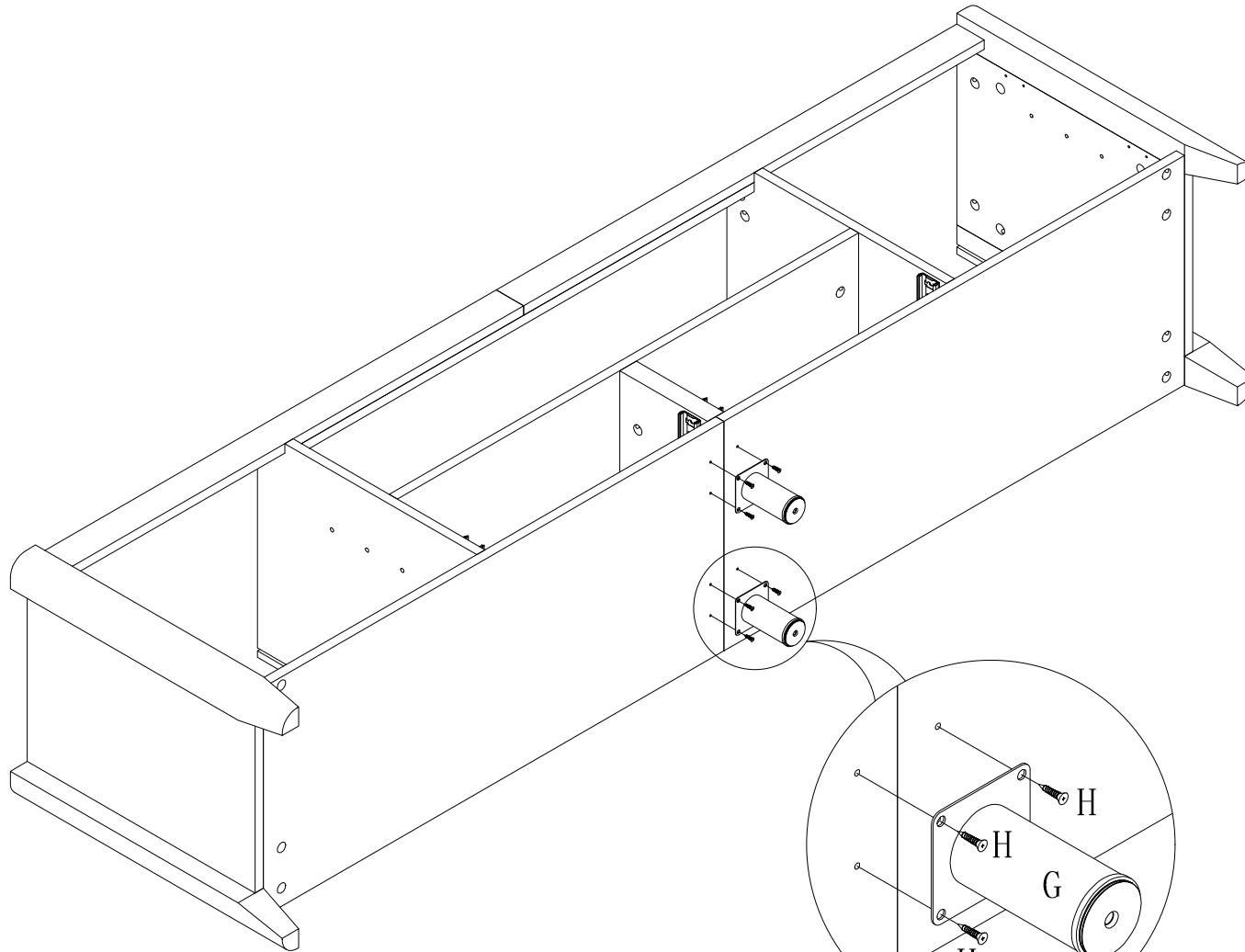





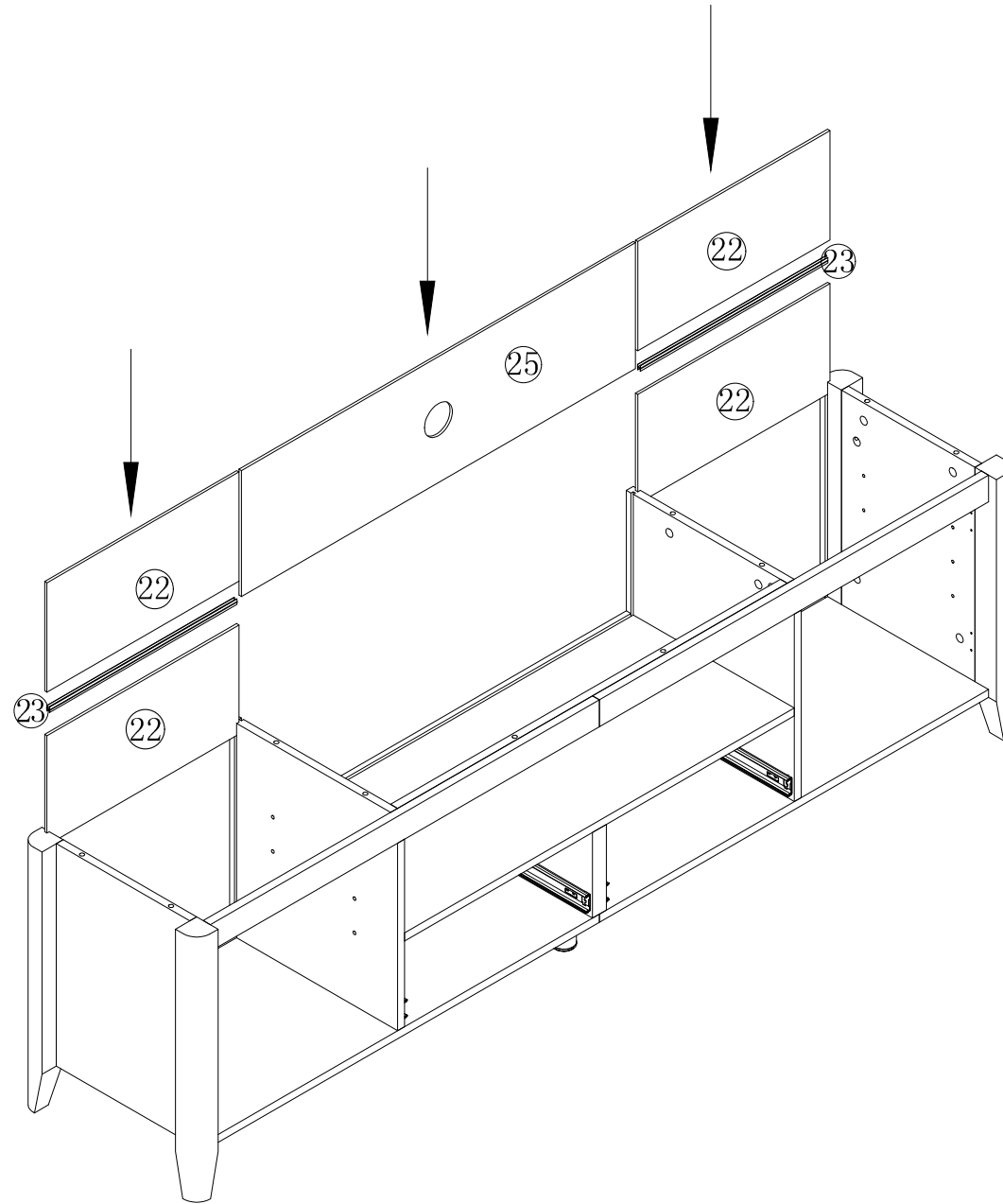

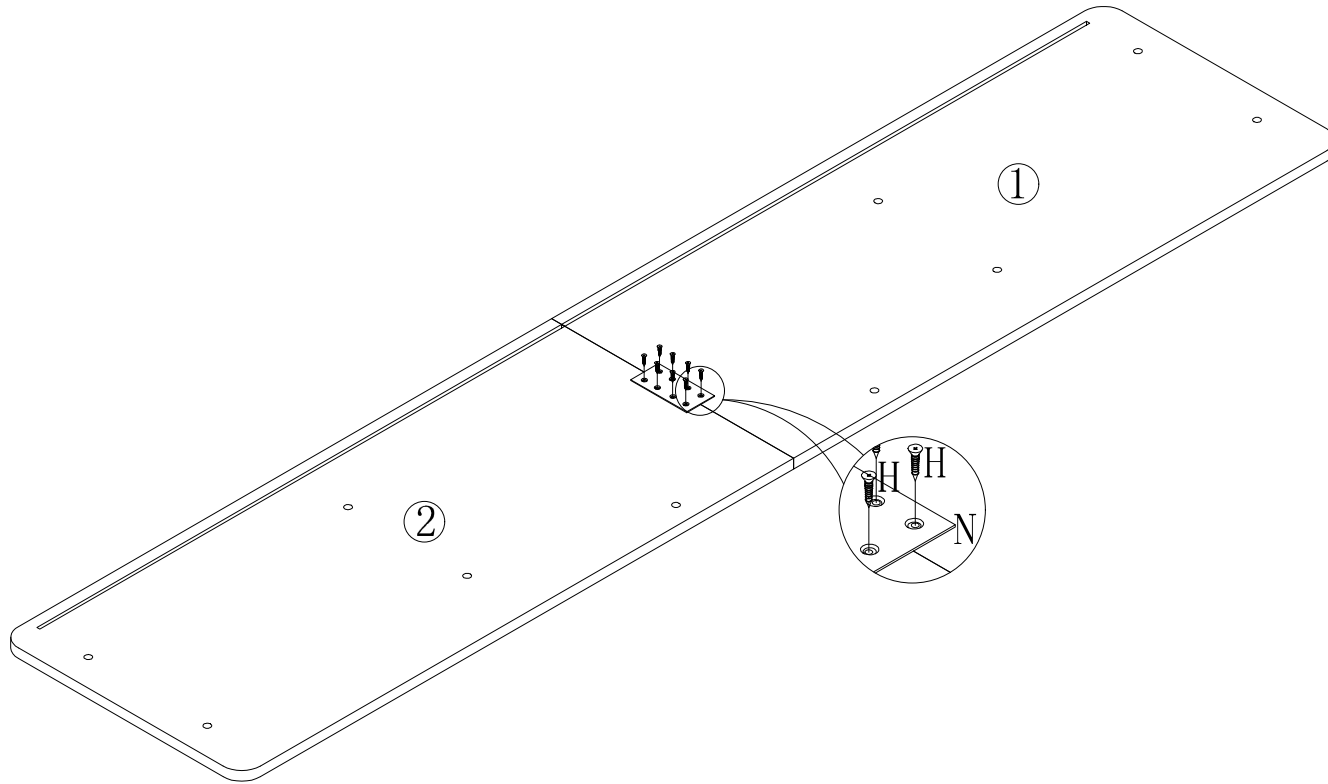
G	 38*80mm	2
H	 3.5*14mm	8



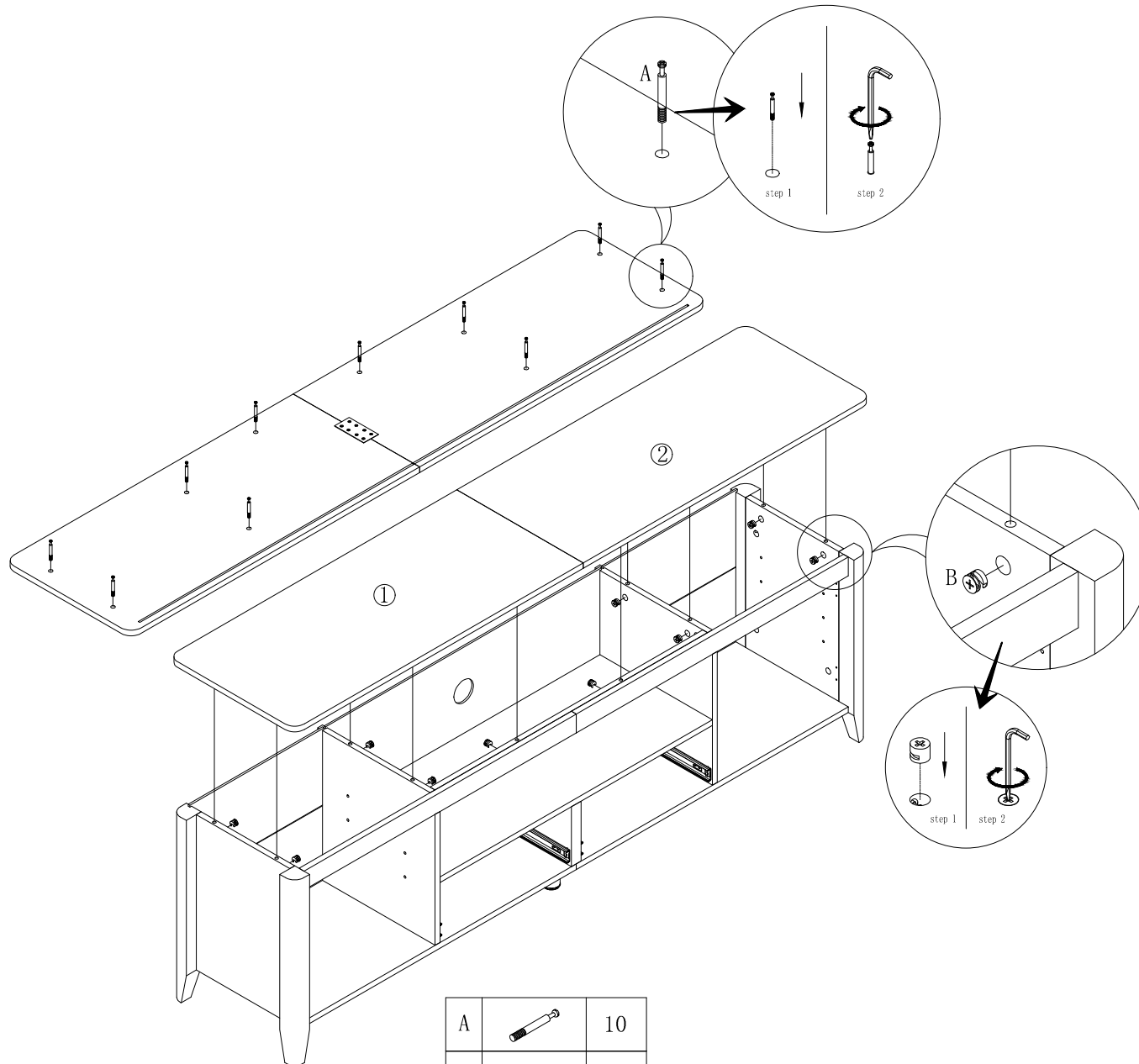

N		1
H	 3.5*14mm	8



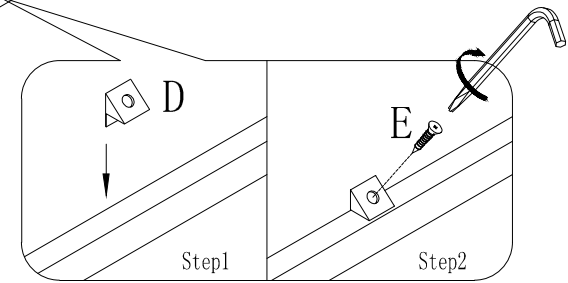
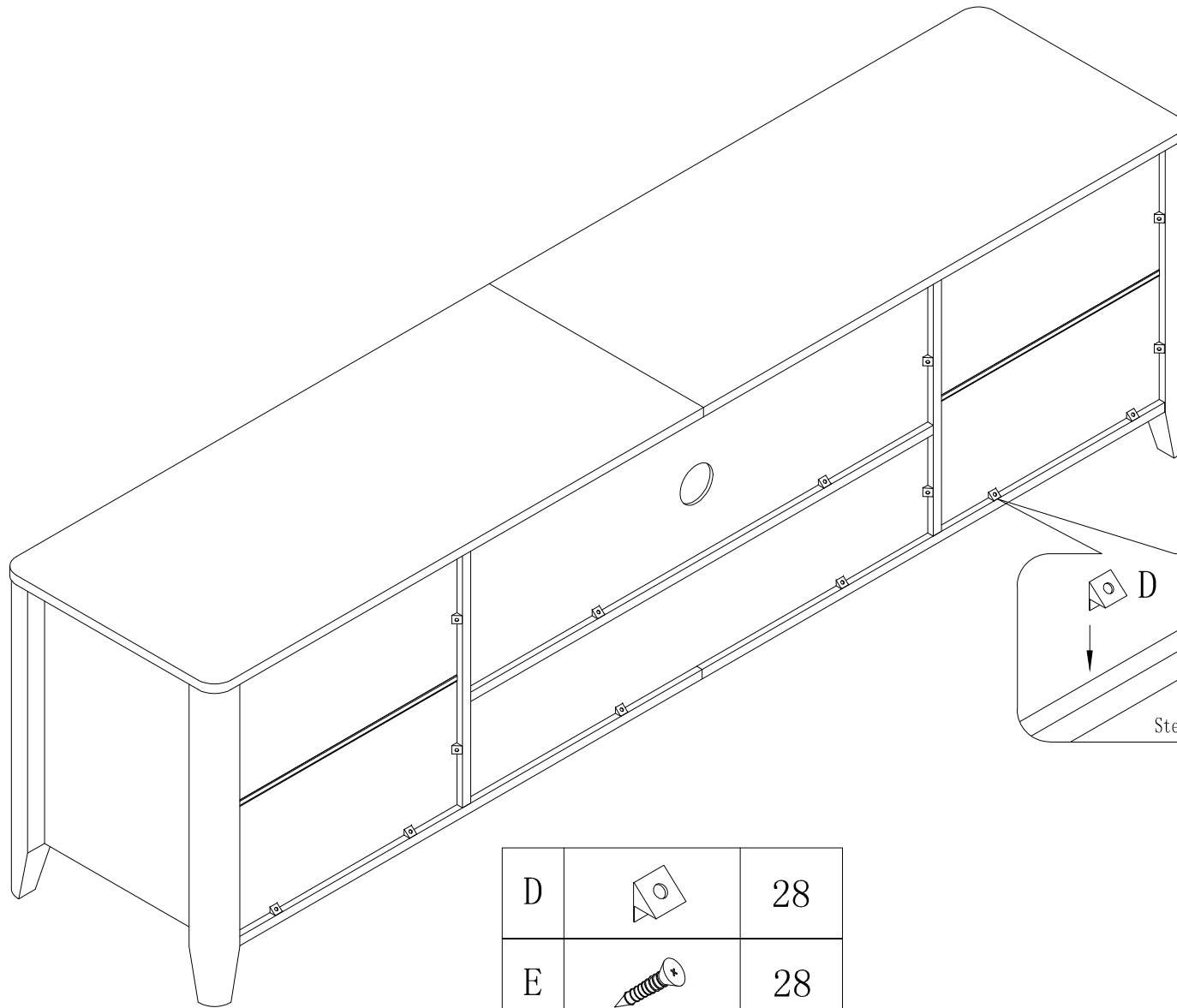

A		10
B		10



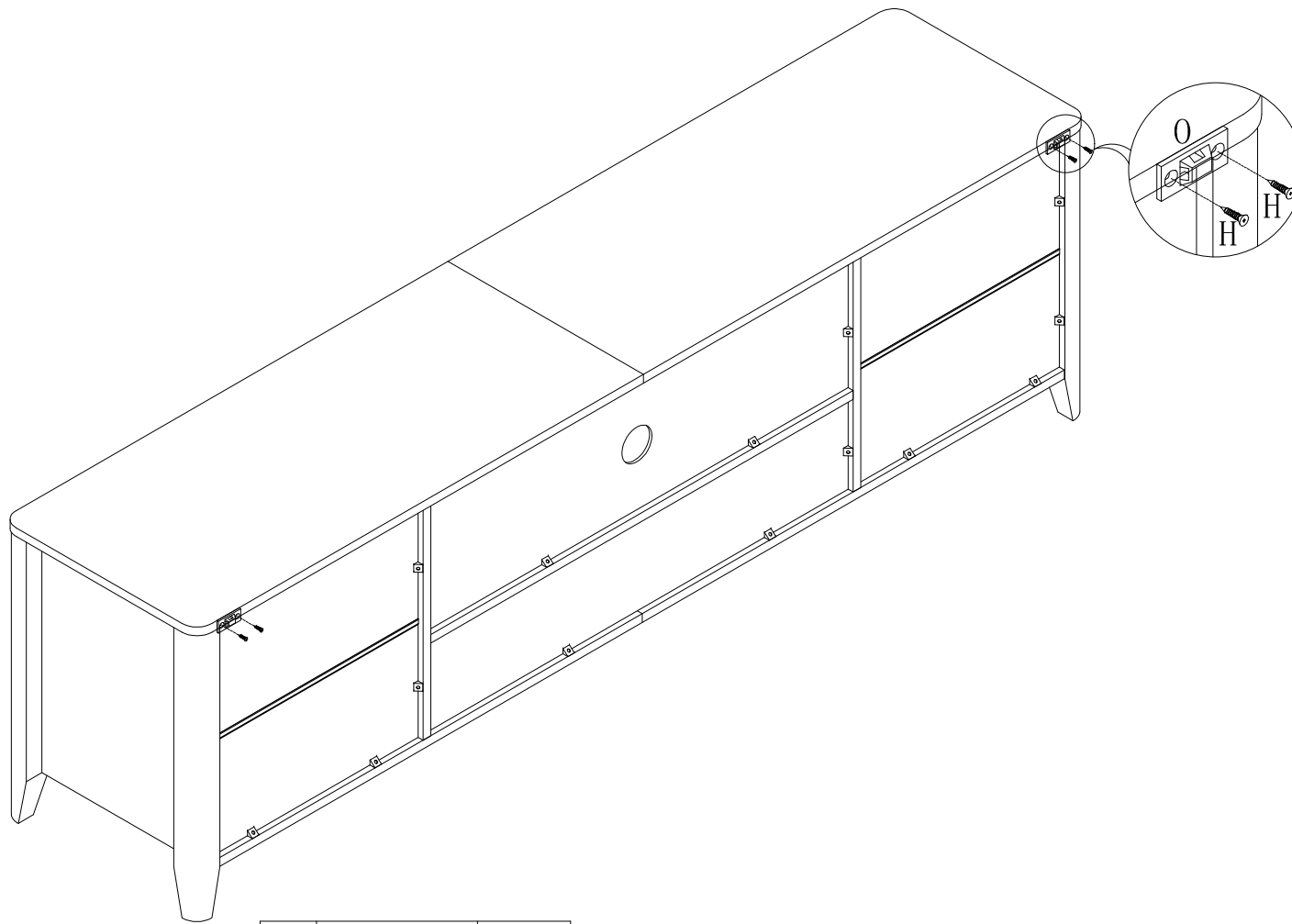

D		28
E	 3.0*14mm	28



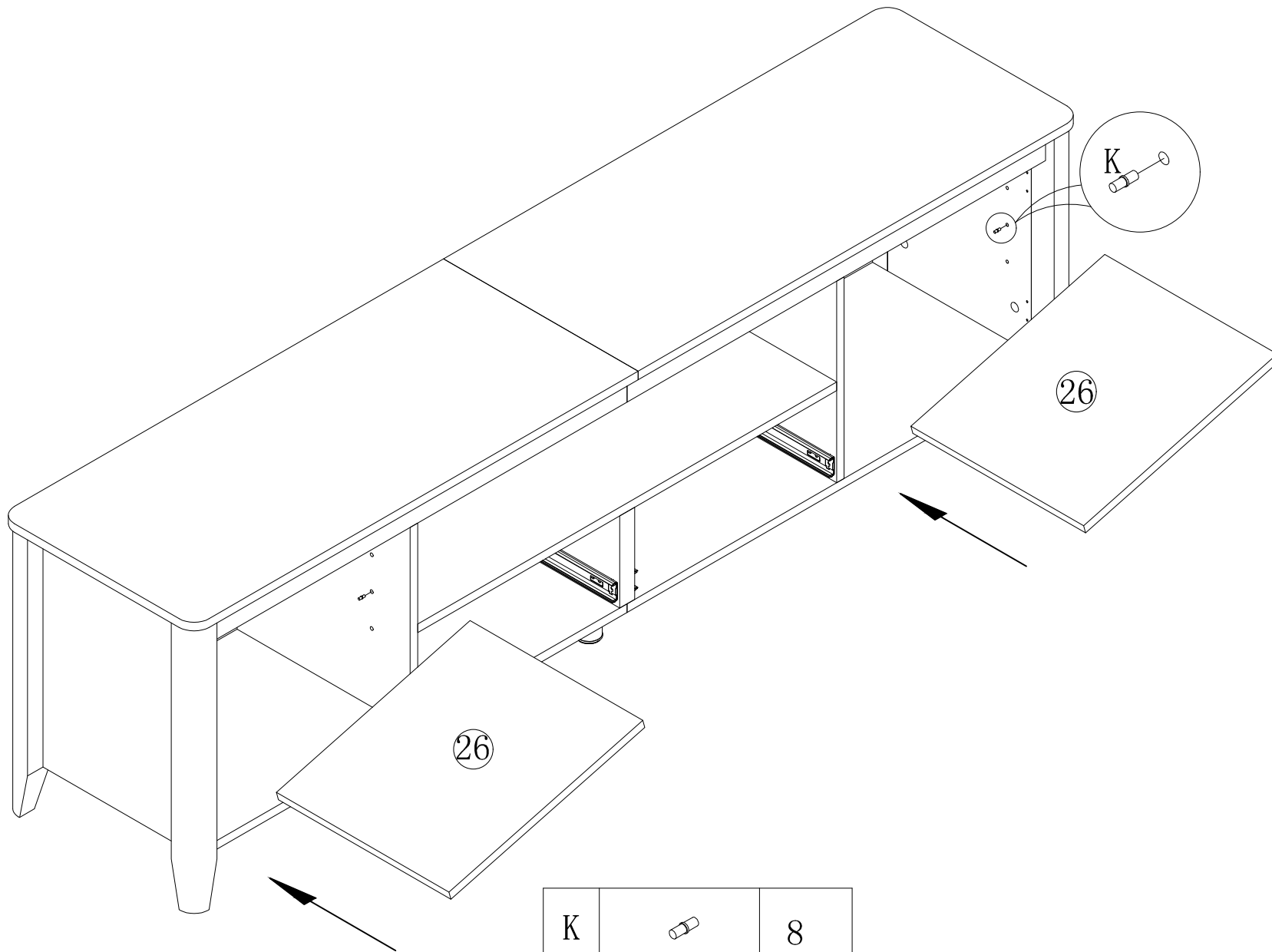

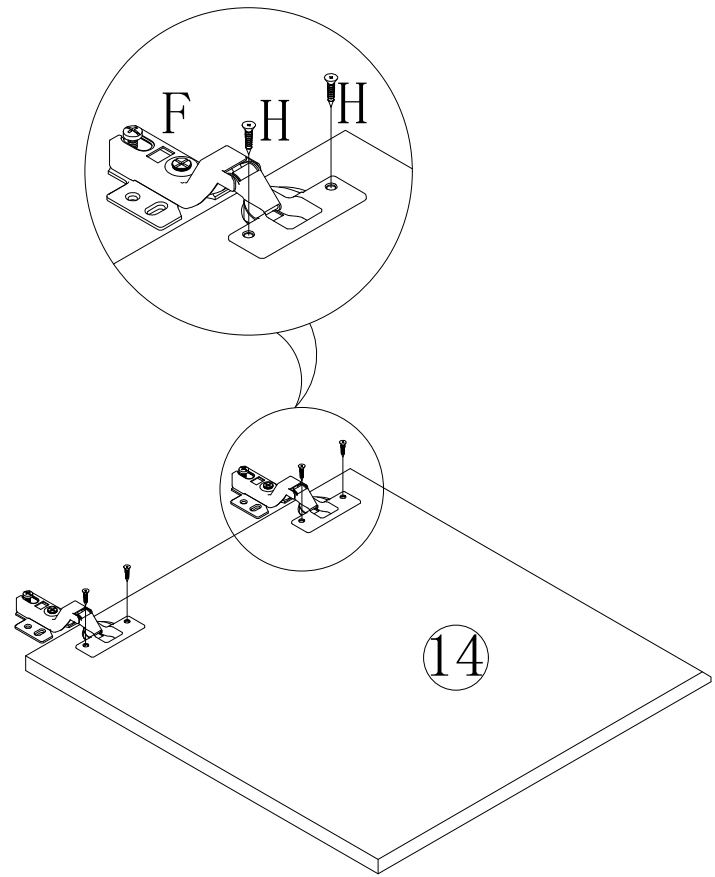
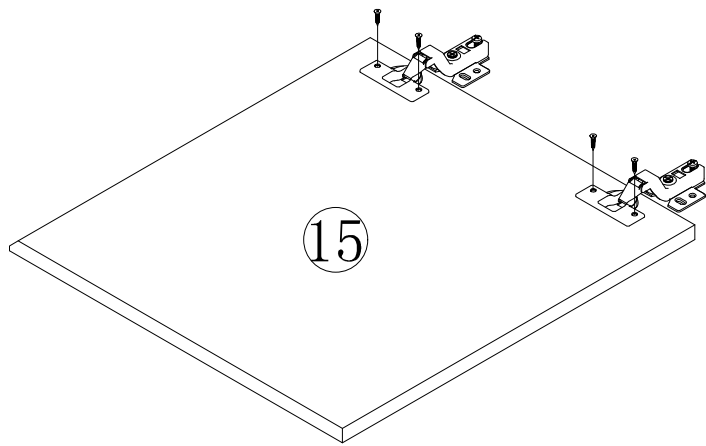
H	 3.5*14mm	4
O	 3.5*35mm 3.5*14mm	2

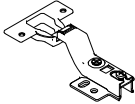

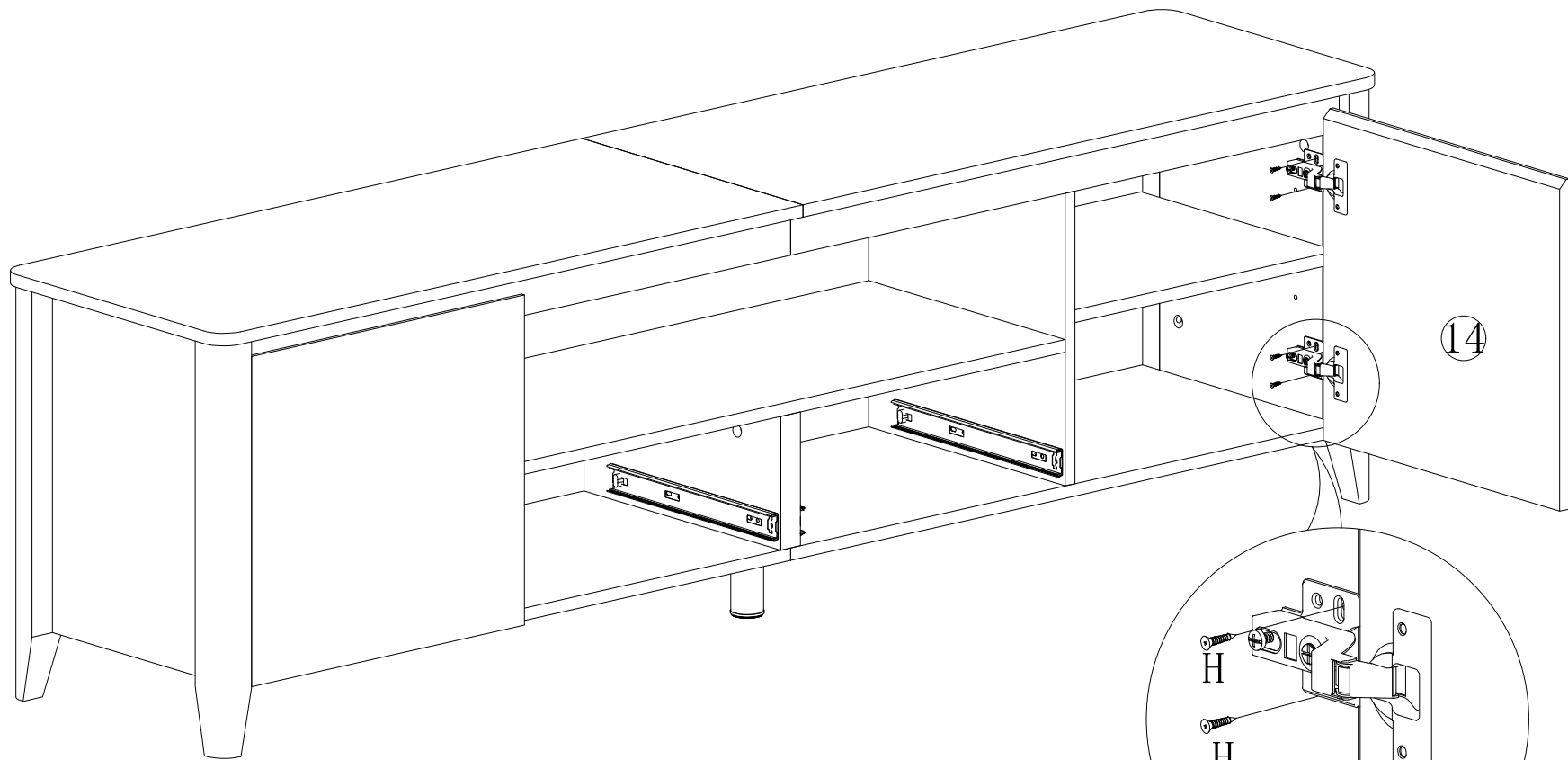

F		4
H	 3.5*14mm	8



H	 3.5*14mm	8
---	---	---

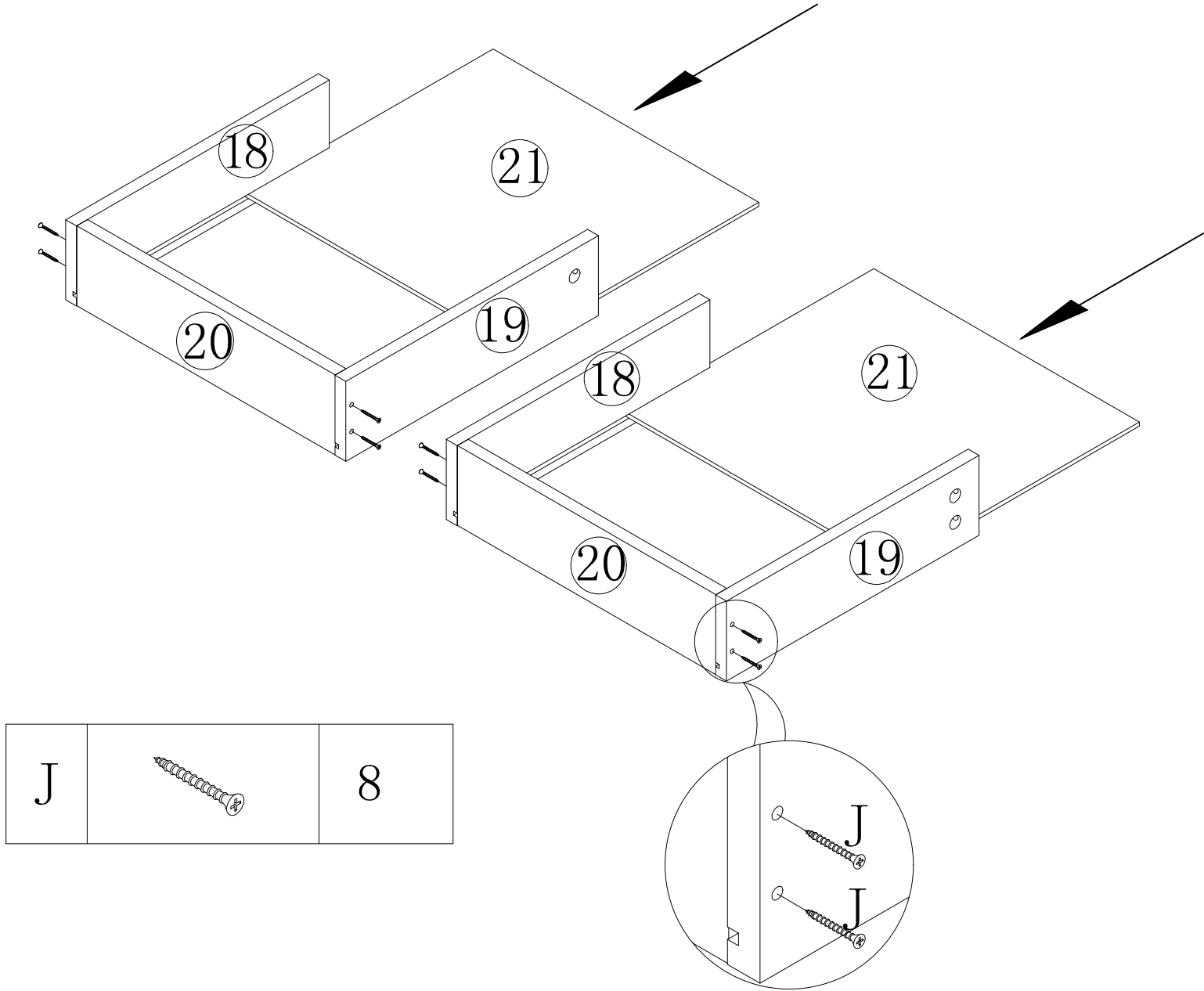

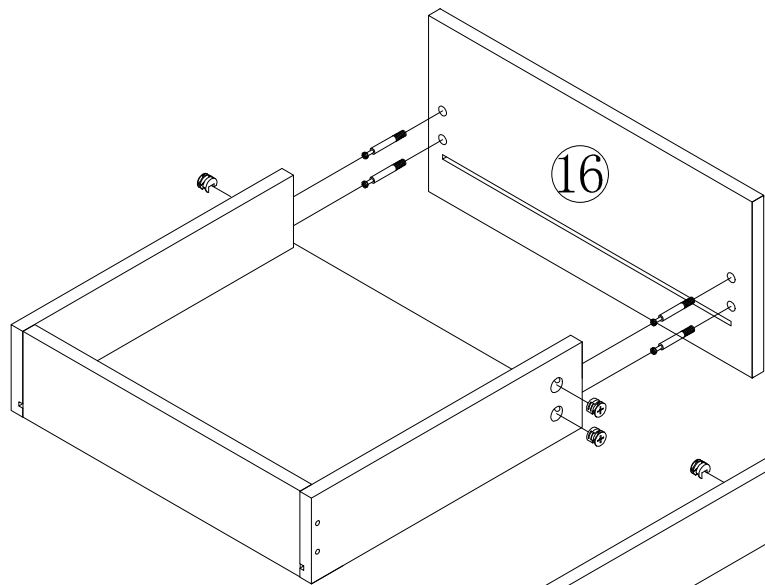

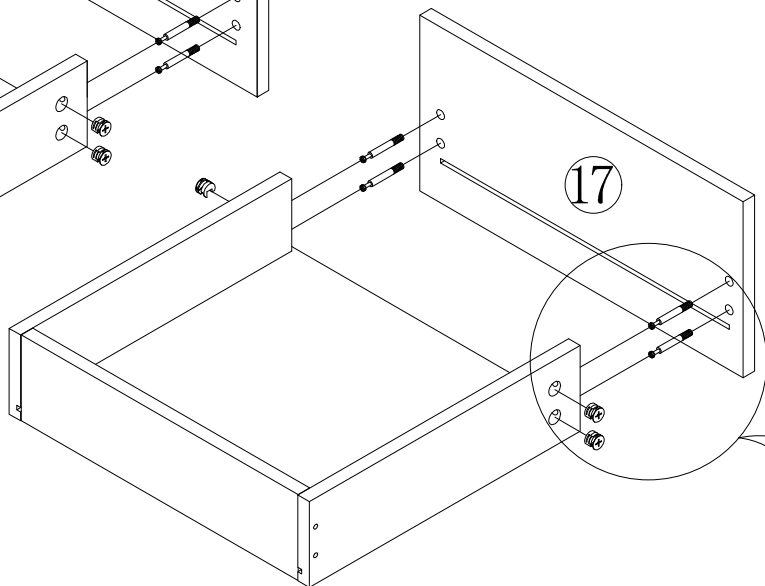

16



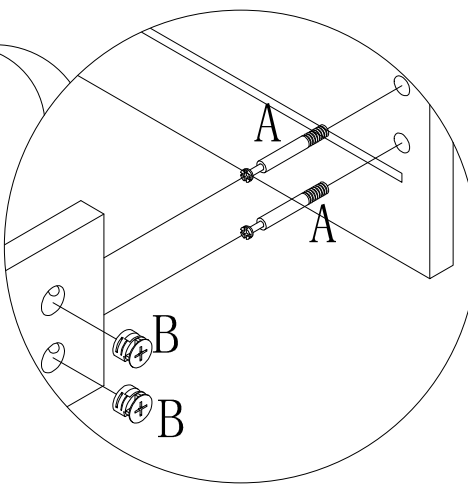
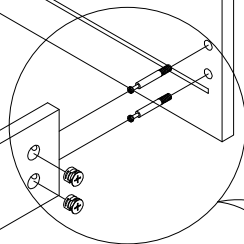

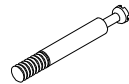
17

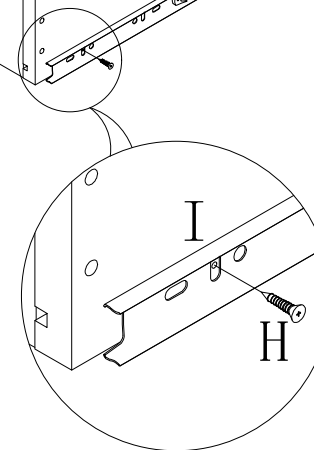
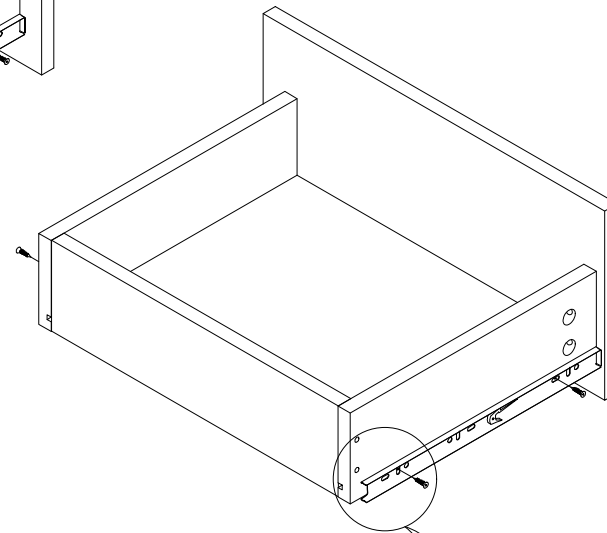
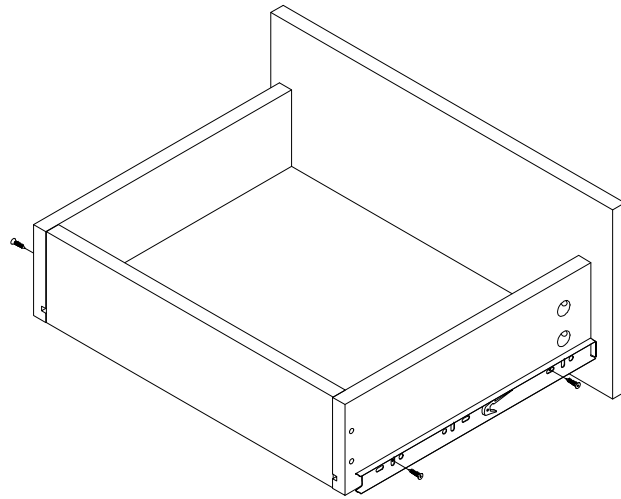

A		8
B		8



H	 3.5*14mm	8
I		4

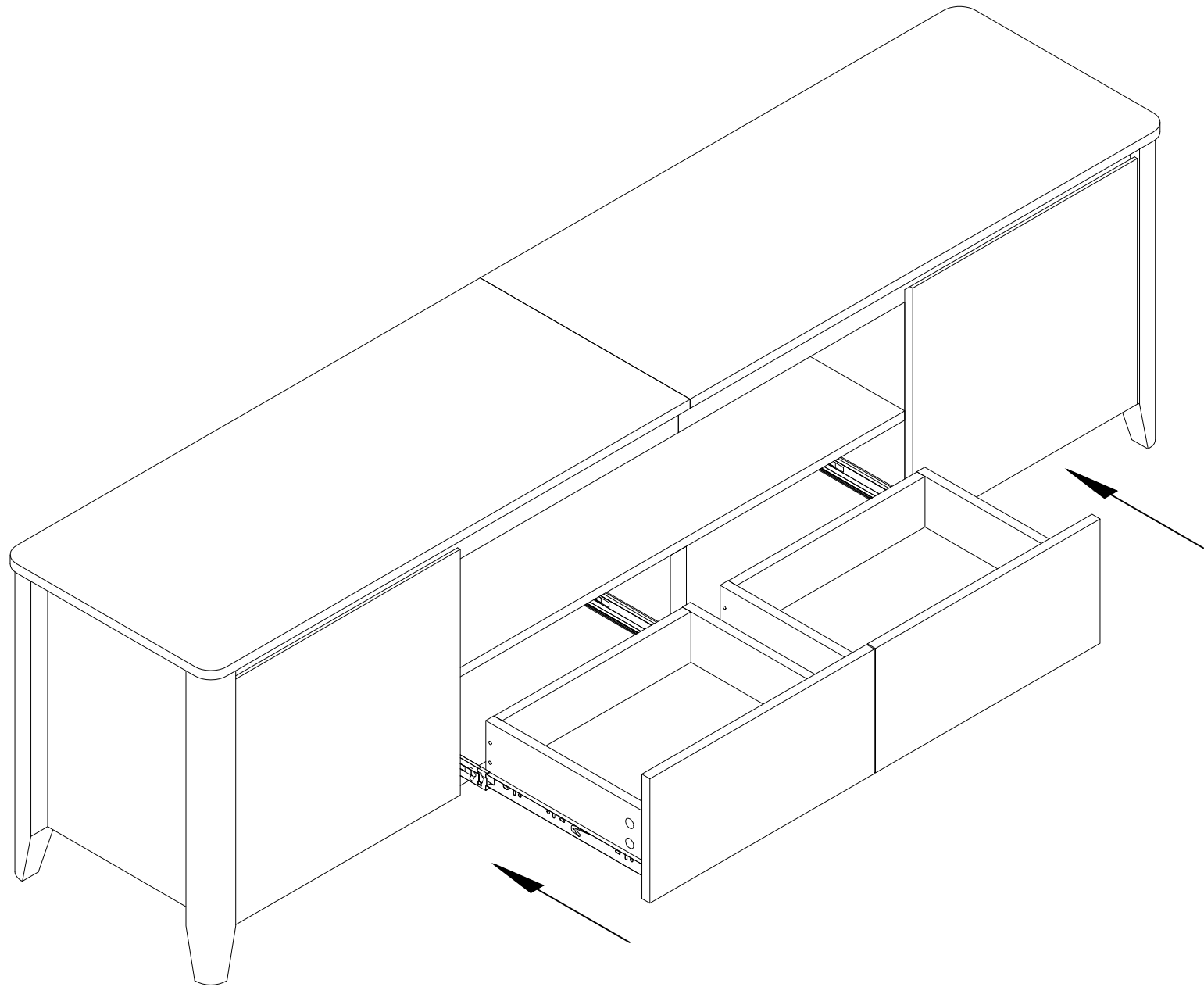

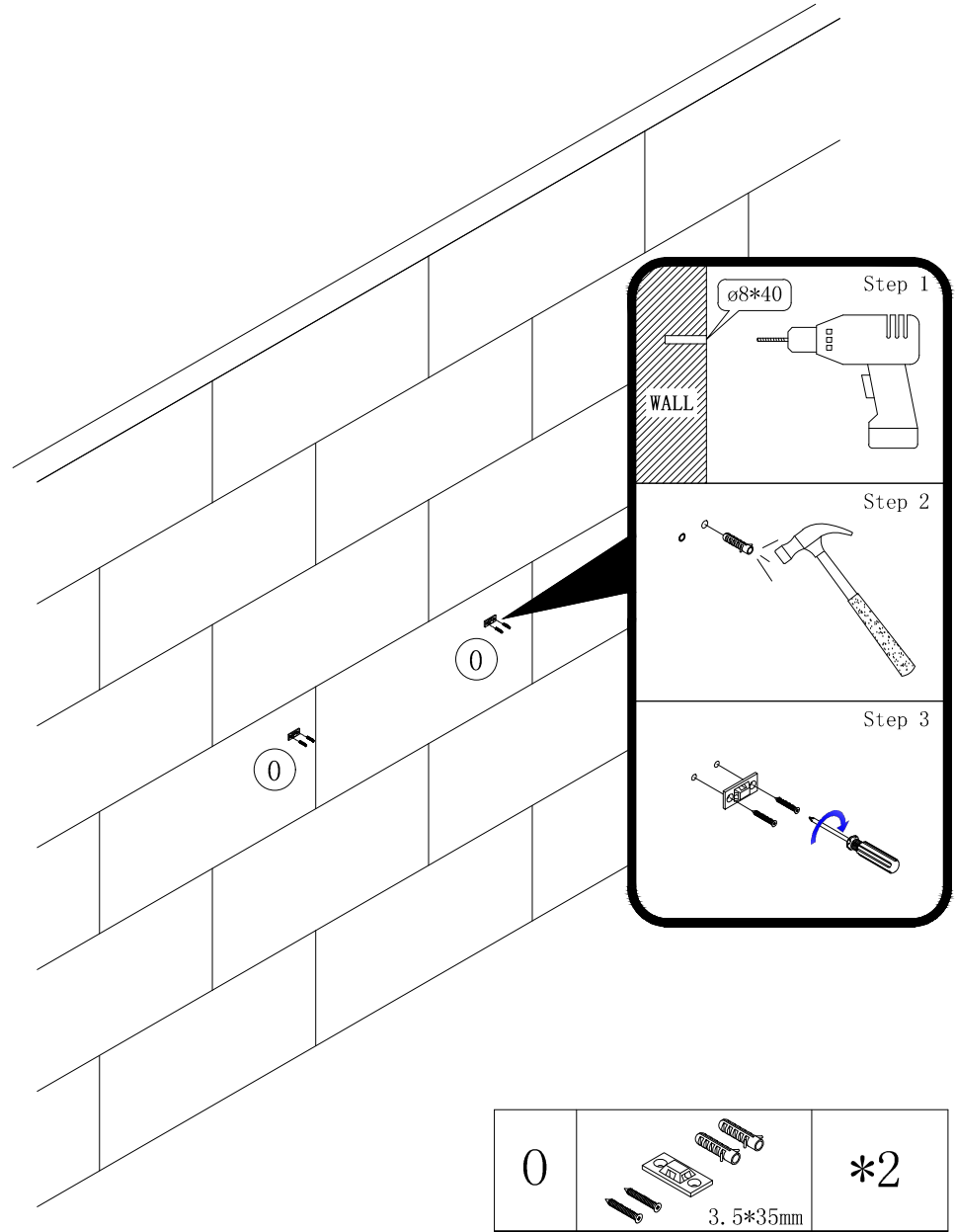

Step 1

ø8*40

WALL

Step 2

Step 3

0	 <p>3.5*35mm</p>	*2
---	---	----

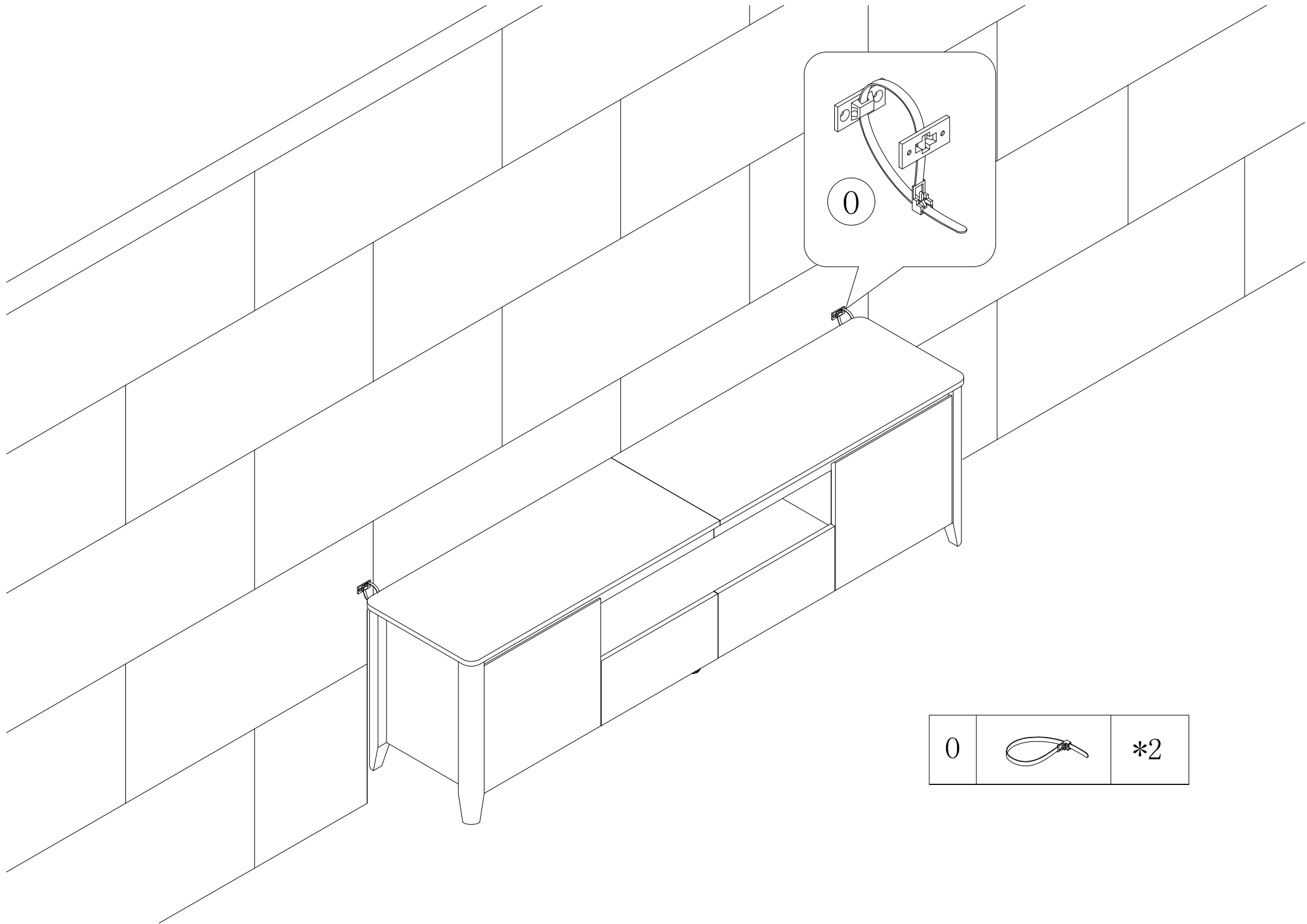

0		*2
---	---	----