

ASSEMBLY INSTRUCTION

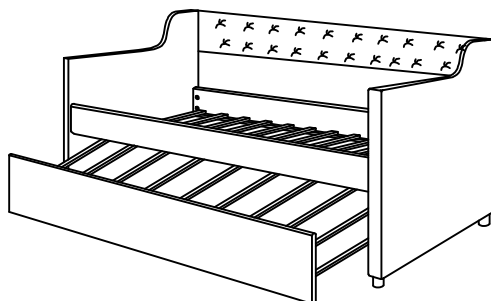

TWIN BED













Part list

Hardware







W876P170748/W876P170757

No.	Parts	Description	QTY
A		Headboard	1
B		Footboard	1
J		Foot	4

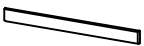
W876P170748/W876P170757

No.	Parts	Description	QTY
1		Bolt 5/16"*25mm	16
2		Flat Washer	20
3		Spring washer 5/16"	20
4		Bolt 5/16"*45mm	4
5		L metal connector	4
6		Wheel	4
7		Wood Screw #8*30mm	40
8		Large L metal connector	4
9		Wood Screw #8*15mm	32
10		Allen Wrench	1

W876P170752/W876P170762

C		Bed Rail	2
D		Backboard	1
F		Front panel of under bed	1
G		Back panel of under bed	1
E		Bed Slats	1
H		Slats of under Bed with wood block	1

ASSEMBLY TOOLS REQUIRED(NOT INCLUDED)

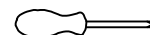

PLEASE BE CAREFUL DO NOT DAMAGE THE HOLE POSITION WHEN YOU USE POWER TOOLS!

Detail View

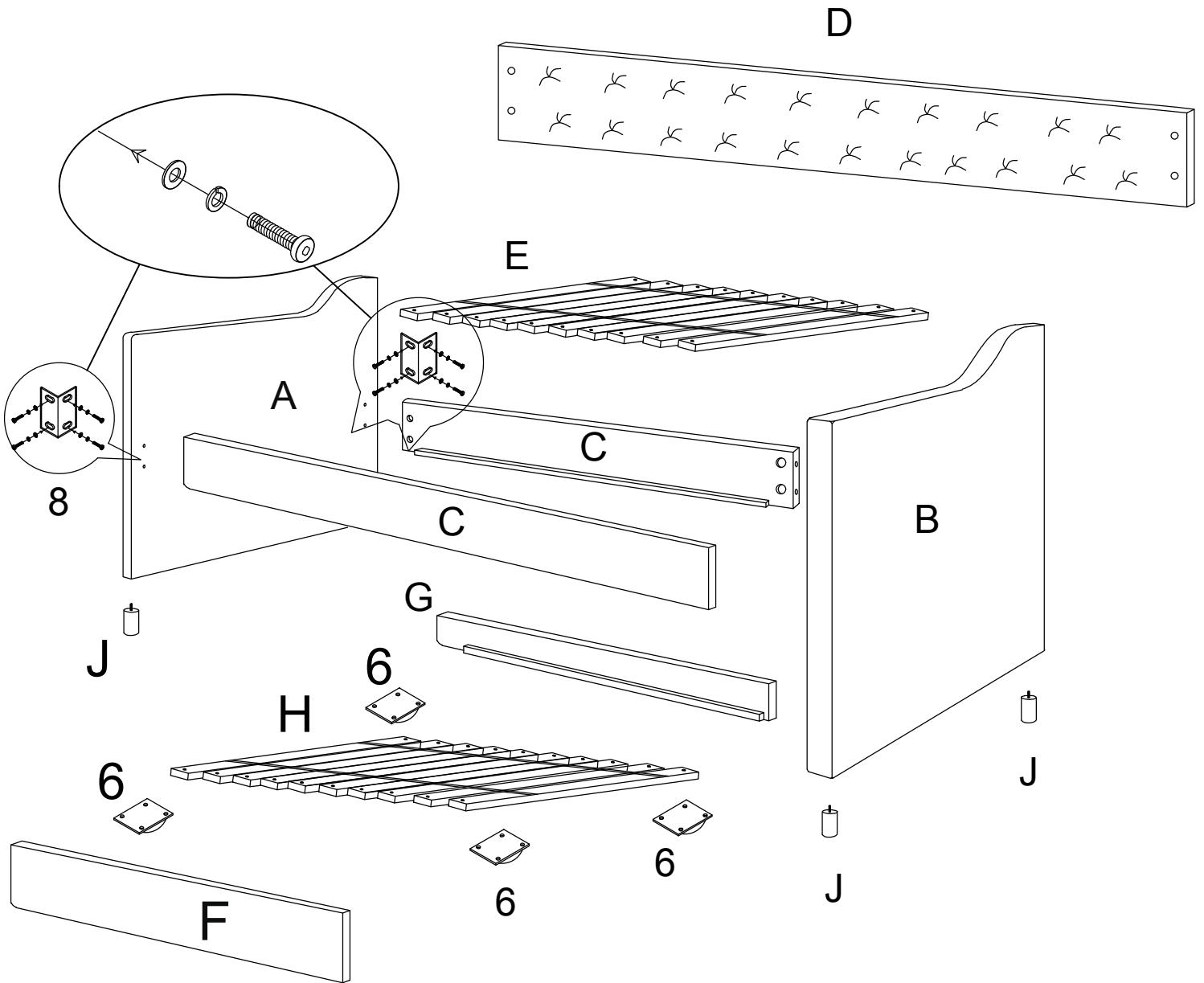

- STEP 1:**
1. Screw four feet into the bottom of Headboard (A) and Footboard (B), as shown in Figure 1.
 2. Screw Hang Bolts (1) into Headboard (A) and Bed Rail (C) through L Metal Connector (8) as shown in Figure 2.
 3. Repeat the steps 2 for Footboard (B).

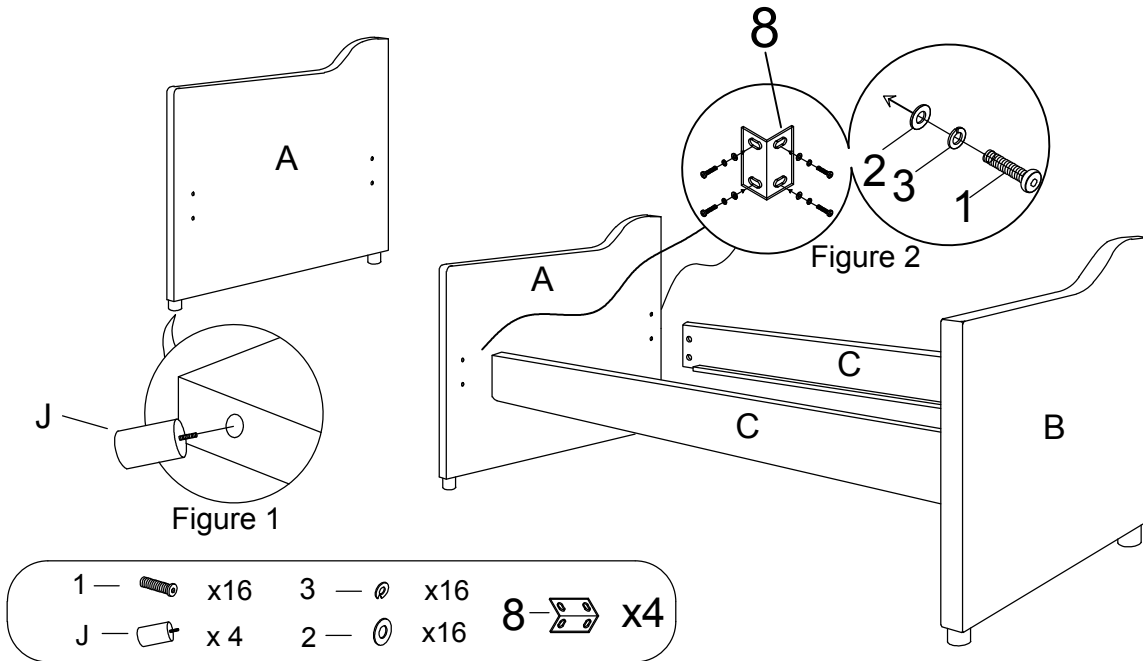

STEP 2:

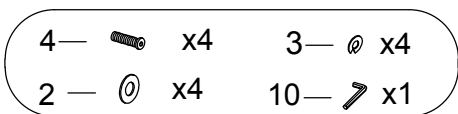
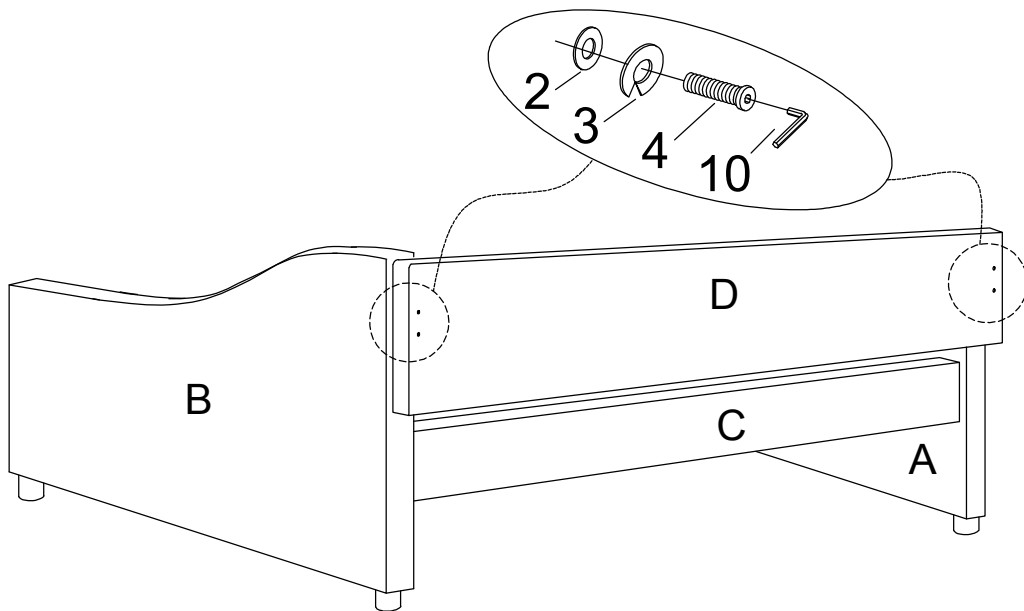

1. Attach Backboard (D) to Headboard (A) and Footboard (B) by using 4 pieces of Bolts (4), 4 pieces of Flat washer (2), and 4 pieces of Spring Washers (3) as shown in the picture.
2. Use Allen Wrench (10) to tighten all Bolts (4) clockwise as shown.

- STEP 3:**
1. Put 10 pieces of Bed Slats (E) on the Bed Rails (C).
 2. Tighten 20 Pieces of Wood Screws (7) clockwise as shown.

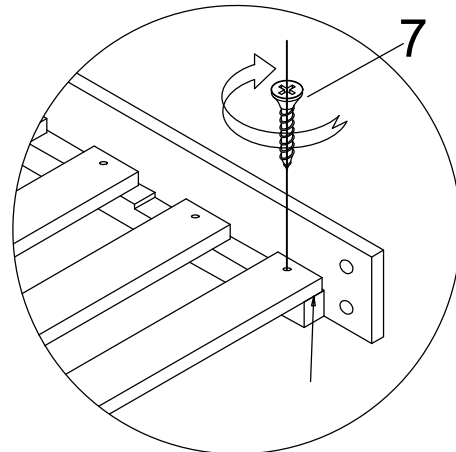
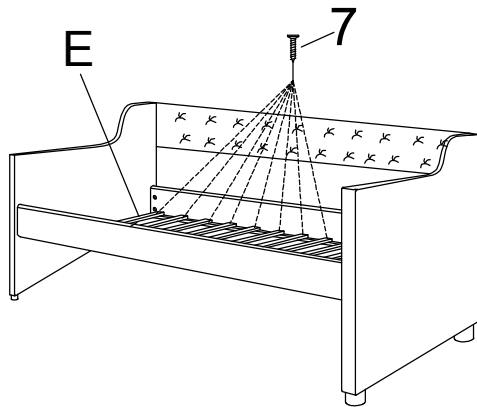
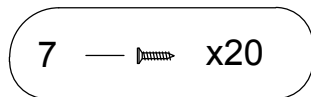
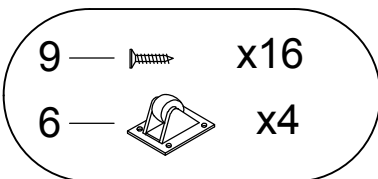
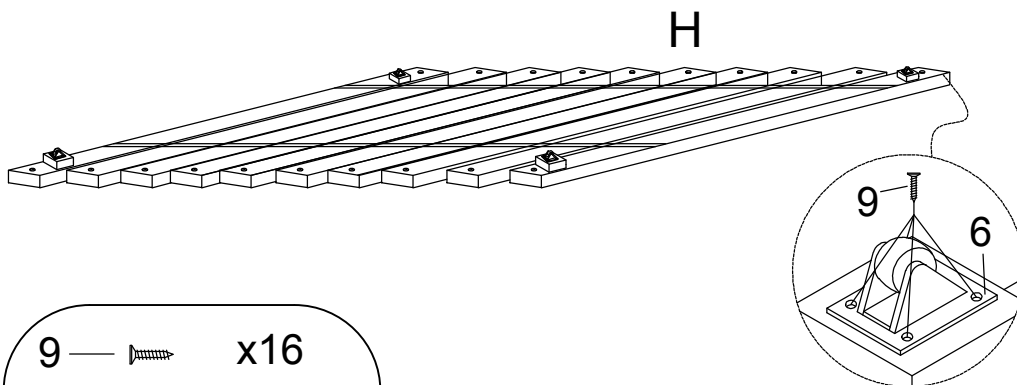

Figure 1
Flush /Affleurer



-
- STEP 4:**
1. Attach 4 pieces of Wheels (6) to the Slats under bed (H) with 16 pieces of Wood Screws (9) as shown in the picture.
 2. Tighten Wood Screws (9) clockwise as shown in the picture.



- STEP 5:**
1. Tighten 4 pieces of Wood Screws (7) to slats of under bed (H) as Figure 1.
 2. Attach both outside 2 pieces Slats of under bed (H) to Front panel of under bed (F) and Back panel of under bed (G) by 4 pieces of L metal connector (5), as Figure 2
 3. Tighten 16 pieces of Wood Screws (9), as shown.

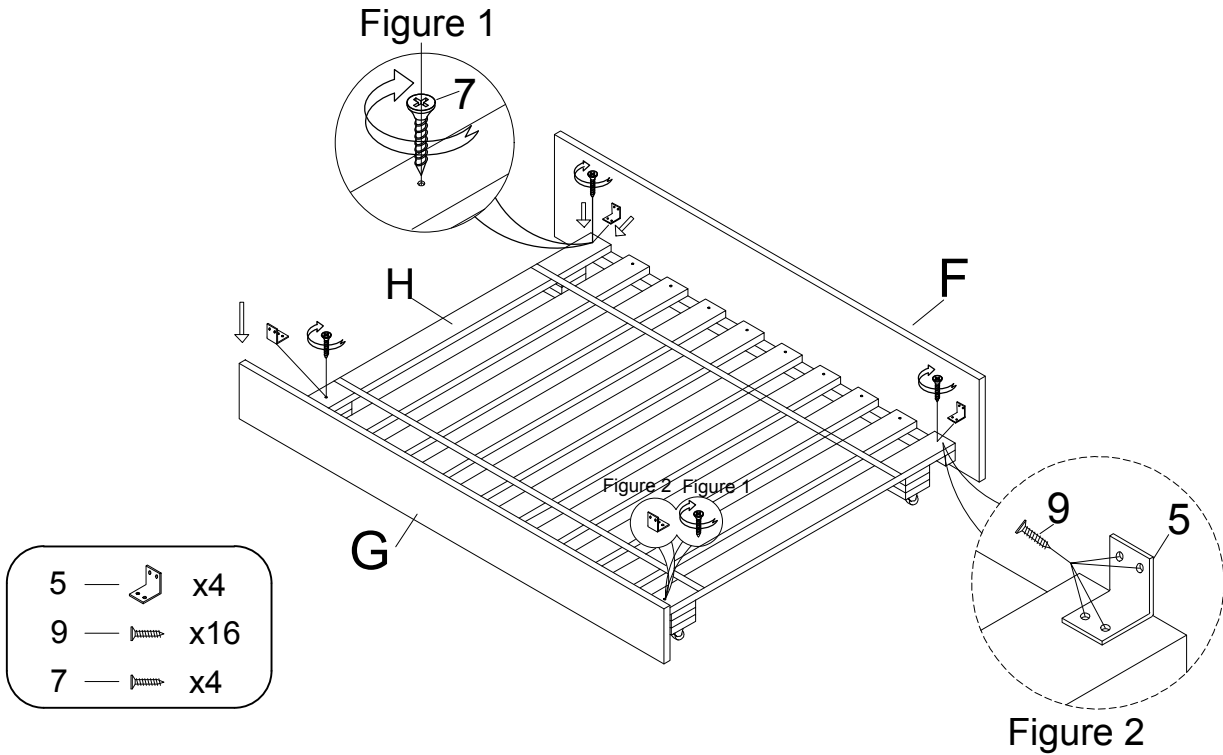

- STEP 6:**
1. Put Slats of under bed (H) between front panel of under bed (F) and Back panel of under bed (G) as shown.
 2. Tighten 16 Pieces of Wood Screws (7) clockwise as shown.

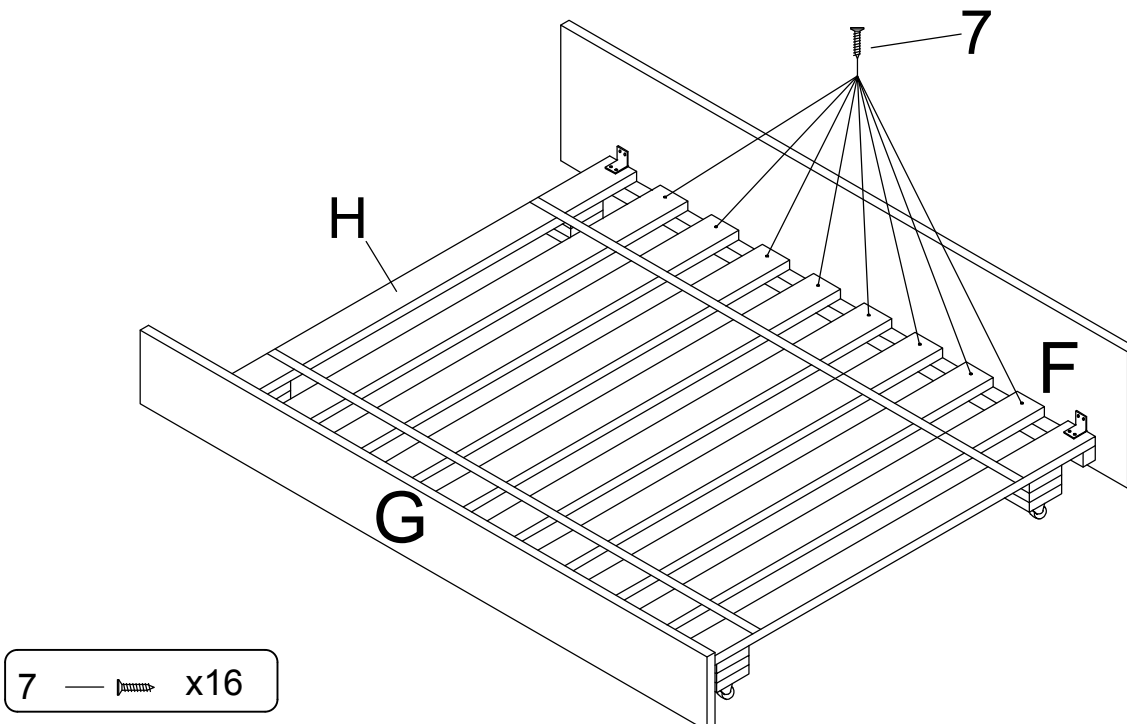

STEP 7: Push the trundle into the Daybed.

