

ASSEMBLY INSTRUCTION

W87667393

W87667395



W87667394

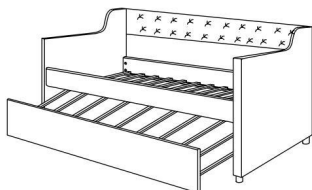











W87667396









Part list

Hardware

W87667393			
No.	Parts	Description	QTY
A		Headboard	1
B		Footboard	1
J		Foot	4

W87667393			
No.	Parts	Description	QTY
1		Hang Bolt 5/16**4"	8
2		Crescent Spacer	8
3		Spring Washer 5/16"	4
4		Nut 5/16"	8
5		Wrench	1
6		Bolt 5/16**1 3/4"	4
7		Flat Washer	4
8		Allen Wrench	1
9		Wheel	4
10		L metal connector	4
11		Wood Screw #8*1"	40
12		Wood Screw #8*3/4"	32

W87667394			
No.	Parts	Description	QTY
C		Bed Rail	2
D		Backboard	1
F		Front panel of under bed	1
G		Back panel of under bed	1
E		Bed Slats	1
H		Slats of under Bed with wood block	1

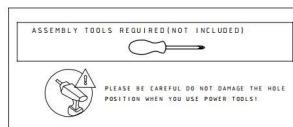

Detail View

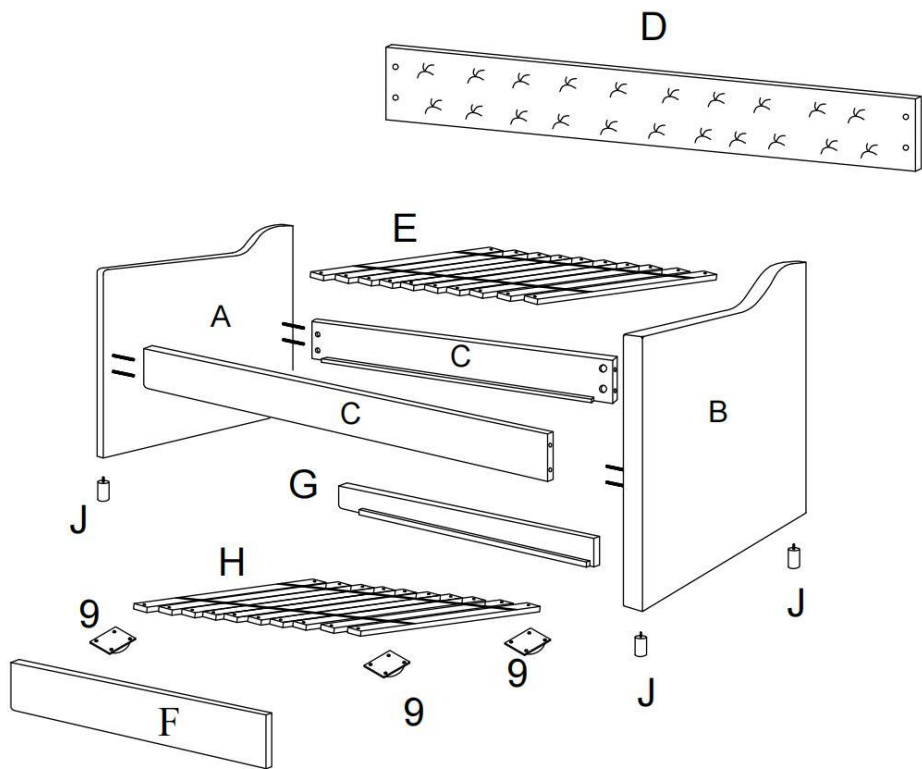

- STEP 1:**
1. Screw four feet into the bottom of about headboard (A), as shown in Figure 1
 2. Screw Hang Bolts (1) into Headboard (A). Make sure there is enough length of the Hang Bolts (1) for next step as shown in Figure 2.
 3. Insert Hang Bolts (1) through the hole of Bed Rails (C) as shown in Figure 3.
 4. Attach Bed Rail (C) to Headboard (A) using Crescent Spacer (2), and Nut (4). Tighten with Wrench (5) as shown in Figure 4. Don't tight Nut (4) fully.
 5. Repeat the steps 1,2,& 3 for Footboard (B).
 6. When Headboard (A), Footboard (B) and Bolt Rails (C) fixed, please fully tighten all Nuts (4)

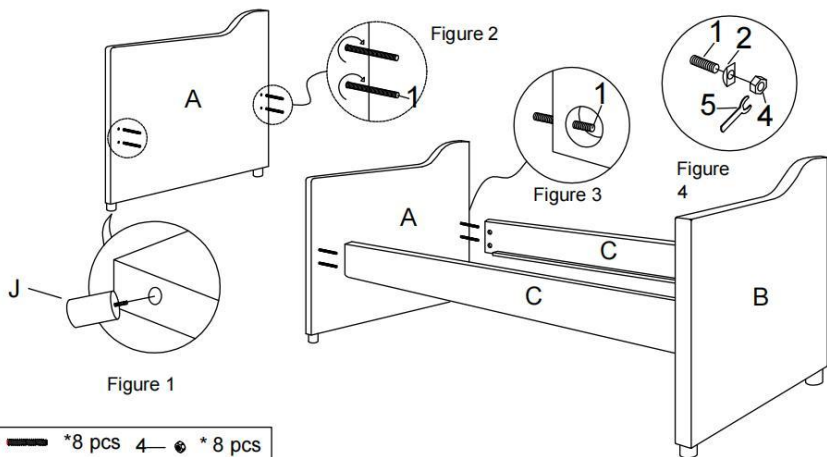

Figure 1

Figure 2

Figure 3

Figure 4

- | | | | | | |
|-----|--|--------|-----|--|--------|
| 1 — | | *8 pcs | 4 — | | *8 pcs |
| 2 — | | *8 pcs | 5 — | | *1 pcs |
| J — | | *4 pcs | | | |

STEP 2:

1. Attach Backboard (D) to Headboard (A) and Footboard (B) by using 4 pieces of Bolts (6), 4 pieces of Flat washer (7), and 4 pieces of Spring Washers (3) as shown.
2. Use Allen Wrench (8) to tighten all Bolts (6) clockwise as shown.

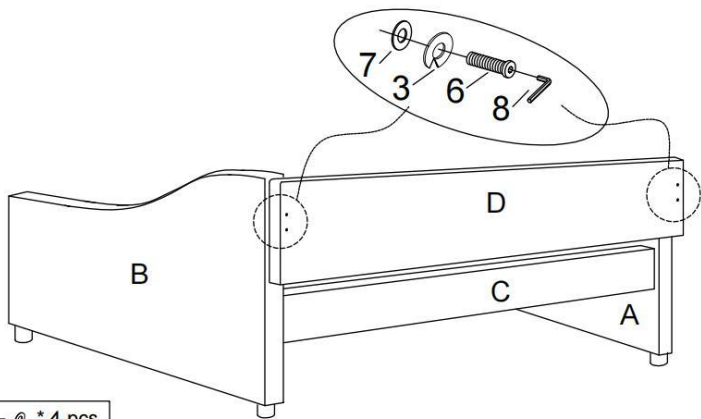

- | | | | | | |
|-----|--|--------|-----|--|--------|
| 6 — | | *4 pcs | 3 — | | *4 pcs |
| 7 — | | *4 pcs | 8 — | | *1 pc |

- STEP 3:**
1. Put 10 pieces of Bed Slats (E) on the Bed Rails (C).
 2. Install Slat Pack with slats starting and ending flush with the end of the support cleat attached to your bed rails **Figure 1**.
 3. Using Screw driver to tighten 20 Pieces of Wood Screws (11) clockwise as sho

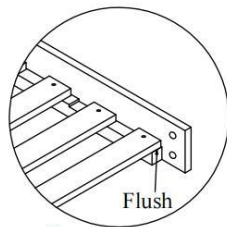
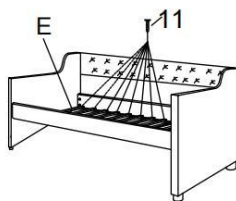
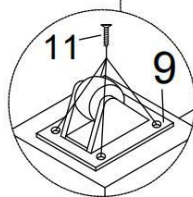
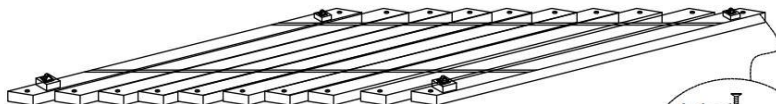

Figure 1

11 — 20 pcs #8*1"

- STEP 4:**
1. Attach 4 pieces of Wheels (9) to the Slats under bed (H) with 16 pieces of Wood Screws (11) as shown.
 2. Use Screw driver to tighten to tighten Wood Screws (11) clockwise as shown.



11 — 16 pcs #8*1"

- STEP 5:**
1. Attach both outside 2 pieces Slats of under bed (H) to Front panel of under bed and Back panel of under bed (G) by 4 pieces of L metal connector (10), as sh
 2. Use Screw driver to tighten 24 pieces of Wood Screws (12), as shown.

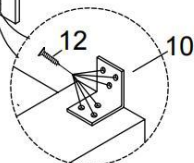
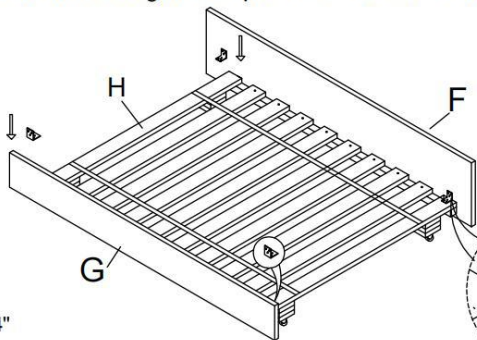

10 — 4 pcs

12 — 24 pcs #8*3/4"

- STEP 6:** 1. Put Slats of under bed (H) on the Bed Box Headboard (F) and Bed Box Headboard (G) as shown.
2. Using Screw driver to tighten 16 Pieces of Wood Screws (11) clockwise as shown.

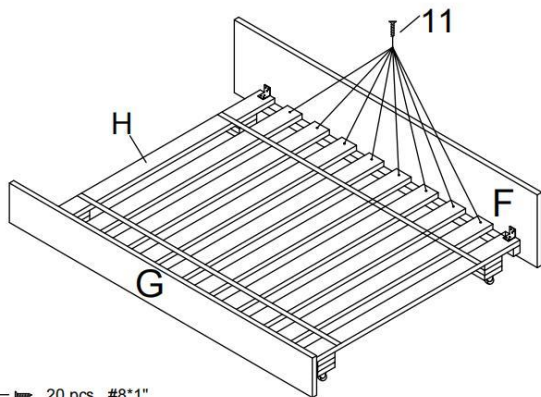

11 — 20 pcs #8*1"

- STEP 7:** Push the Under Box of bed into the Bed.

