

KitchenCart

## English

After assembly, re-tighten the screws every two months to increase stability. Check it several times a year to confirm that the product is secure.

During assembly, the components should be placed on the mat to prevent damage to the surface of the product. Please make sure all accessories are complete. If there are any damaged parts, please contact us and we will ship as soon as possible!





Contact us first if you have any problem, we would do better than Amazon official service.

## Español

Después del ensamblaje, vuelva a apretar los tornillos cada dos meses para mejorar la estabilidad. Verifique varias veces al año para confirmar que el producto es seguro.

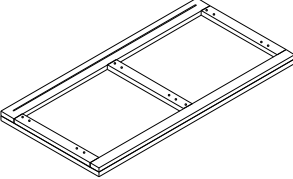
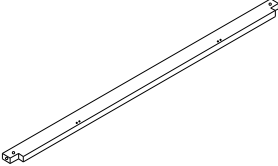
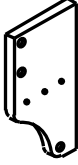
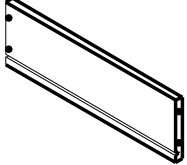
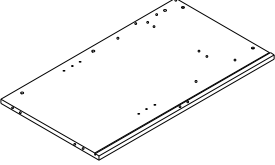
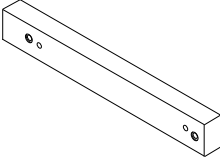
Durante el ensamblaje, los componentes deben colocarse en el tapete para evitar daños en la superficie del producto. Por favor, asegúrese de que todos los accesorios estén completos. Si hay piezas dañadas, contáctenos y le enviaremos lo antes posible.

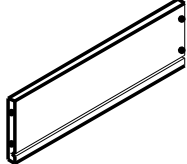
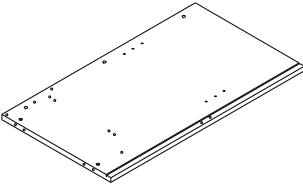
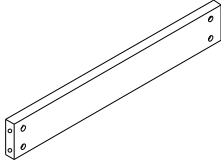
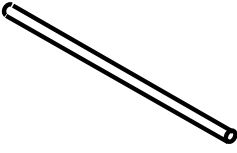
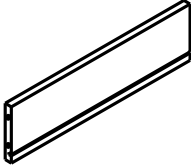
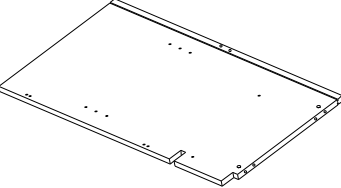
Si tiene algún problema con su producto o pedido, póngase en contacto con nosotros antes de consultar con el servicio de atención al cliente de Amazon, le resolveremos su problema con mayor brevedad.

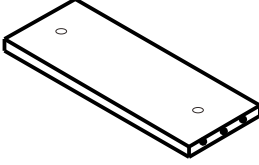
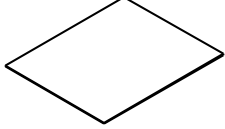
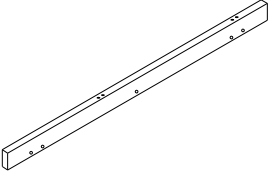
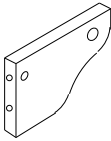
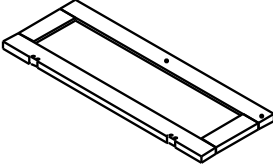
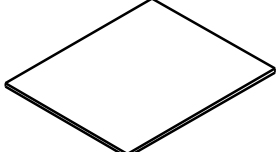
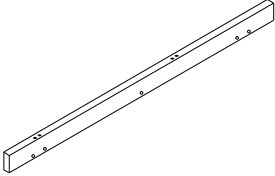
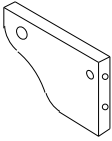
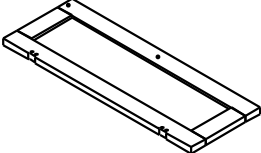
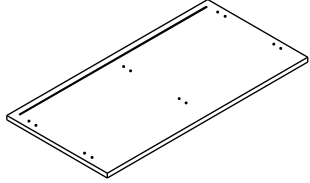
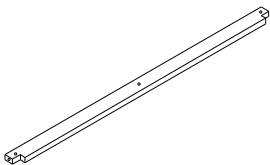
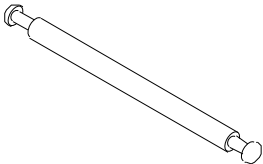
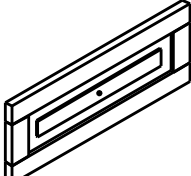
<b>1x 1</b> 	<b>8x 1</b> 	<b>15x 1</b> 	<b>22x 2</b> 
<b>2x 1</b> 	<b>9x 2</b> 	<b>16x 1</b> 	<b>23x 2</b> 
<b>3x 1</b> 	<b>10x 2</b> 	<b>17x 3</b> 	<b>24x 2</b> 
<b>4x 1</b> 	<b>11x 2</b> 	<b>18x 1</b> 	<b>25x 2</b> 
<b>5x 1</b> 	<b>12x 1</b> 	<b>19x 2</b> 	<b>26x 2</b> 
<b>6x 1</b> 	<b>13x 1</b> 	<b>20x 2</b> 	<b>27x 1</b> 
<b>7x 1</b> 	<b>14x 1</b> 	<b>21x 2</b> 	

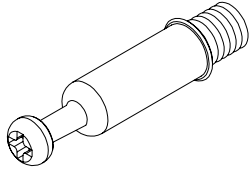
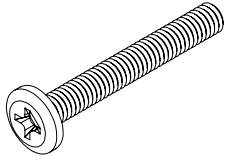
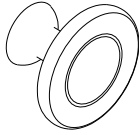
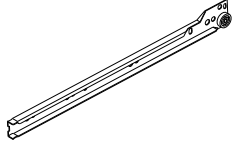
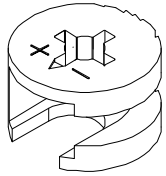
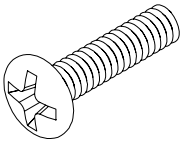
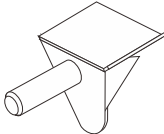
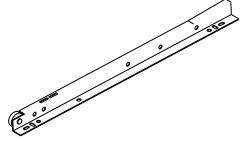
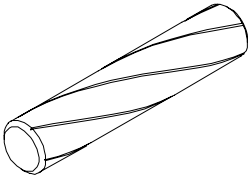
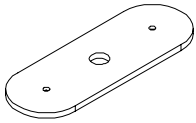
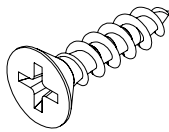
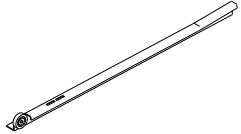
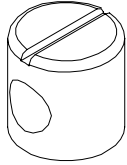
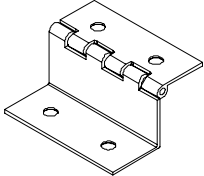
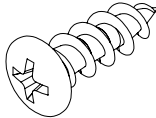
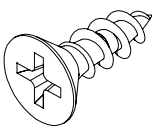
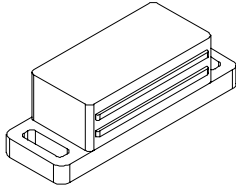
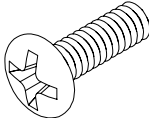
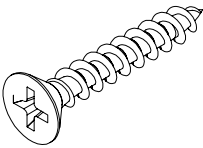
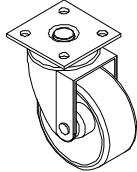
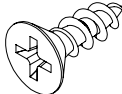
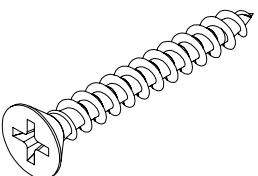
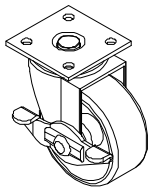
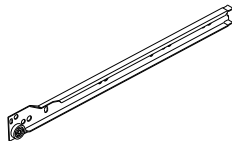
<p><b>A</b> x34</p> 	<p><b>H</b> x 2 M6*45</p> 	<p><b>S</b> x 6</p> 	<p><b>CR</b> x 2</p> 
<p><b>B</b> x34</p> 	<p><b>I</b> x 4 M4*18</p> 	<p><b>T</b> x 8</p> 	<p><b>DL</b> x 2</p> 
<p><b>C</b> x30</p> 	<p><b>J</b> x 4</p> 	<p><b>U</b> x 4 M3*14</p> 	<p><b>DR</b> x 2</p> 
<p><b>D</b> x 2</p> 	<p><b>K</b> x 8</p> 	<p><b>V</b> x16 M5*14</p> 	
<p><b>E</b> x20 M3*12</p> 	<p><b>L</b> x 2</p> 	<p><b>W</b> x 2 M4*8</p> 	
<p><b>F</b> x12 M4*30</p> 	<p><b>Q</b> x 2</p> 	<p><b>X</b> x32 M3*10 +1(spare)</p> 	
<p><b>G</b> x11 M4*35</p> 	<p><b>R</b> x 2</p> 	<p><b>CL</b> x 2</p> 	

01

A	x 7
B	x 3
C	x 4
F	x 2

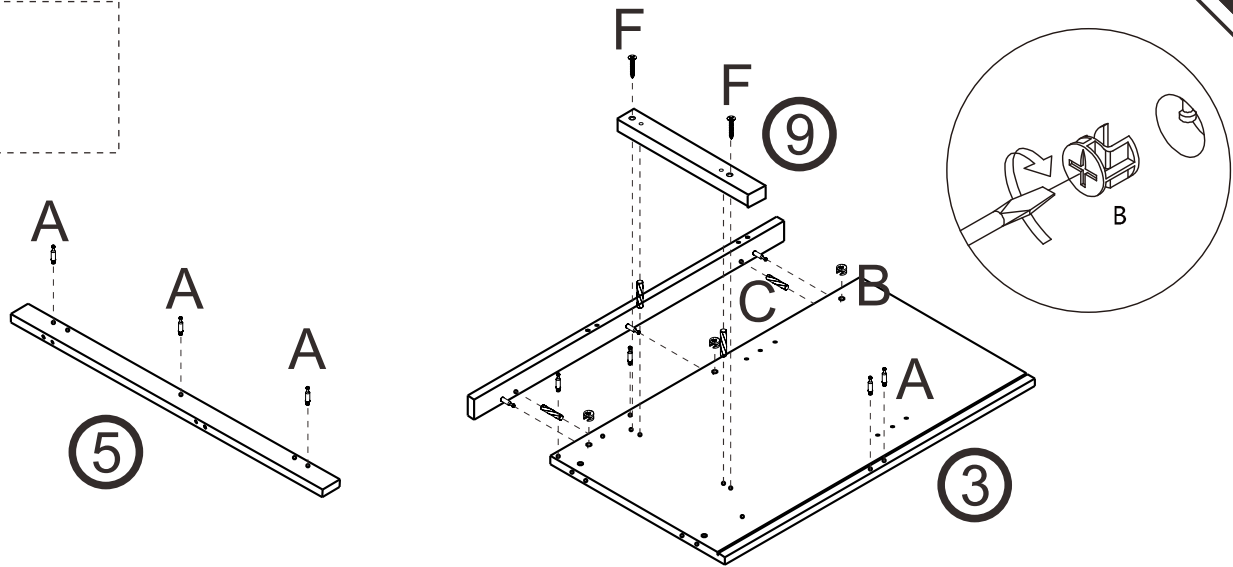

Fix 7 part A to the board(5) and board(3);  
Attach the board(5) and part C to the board(3), and fix them with part B;  
Attach board(9) to the board(3) by tightening part F.

Fija la parte A al tablero(5) y al tablero(3);  
Fijar la tabla(5) y la parte C a la tabla(3), y fijarlos con la parte B;  
Fijar la tabla(9) a la tabla(3) apretando la parte F.

02

A	x 7
B	x 3
C	x 4
F	x 2

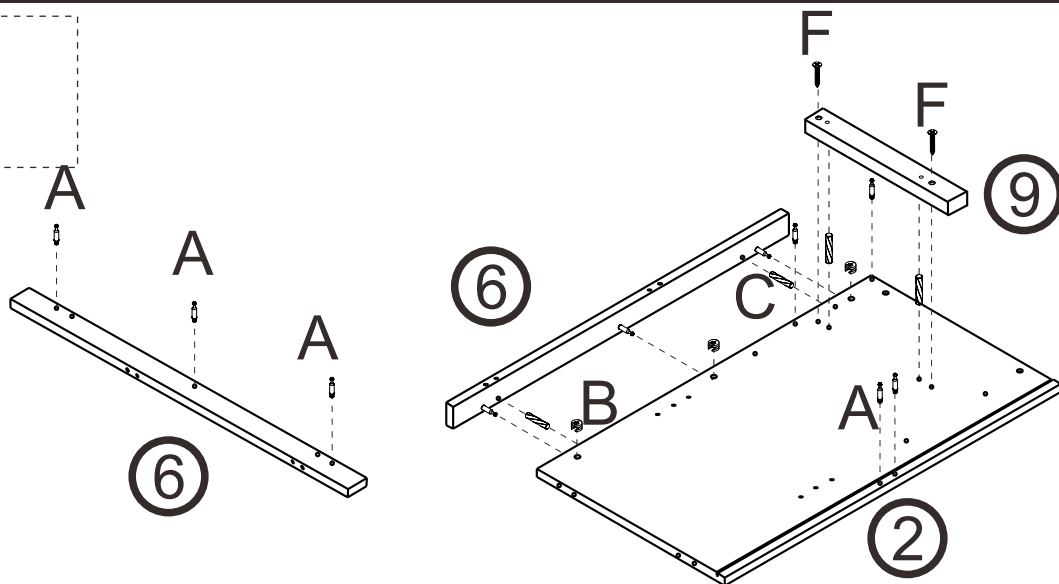

Fix 7 part A to the board(6) and board(2);  
Attach the board(6) and part C to the board(2), and fix them with part B;  
Attach board(9) to the board(2) by tightening part F.

Fija la parte A al tablero(6) y al tablero(2);  
Fijar el tablero(6) y la parte C al tablero(2), y fijarlos con la parte B;  
Fijar la tabla(9) a la tabla(2) apretando la parte F.

03

E	x 4
CL	x 1
CR	x 1

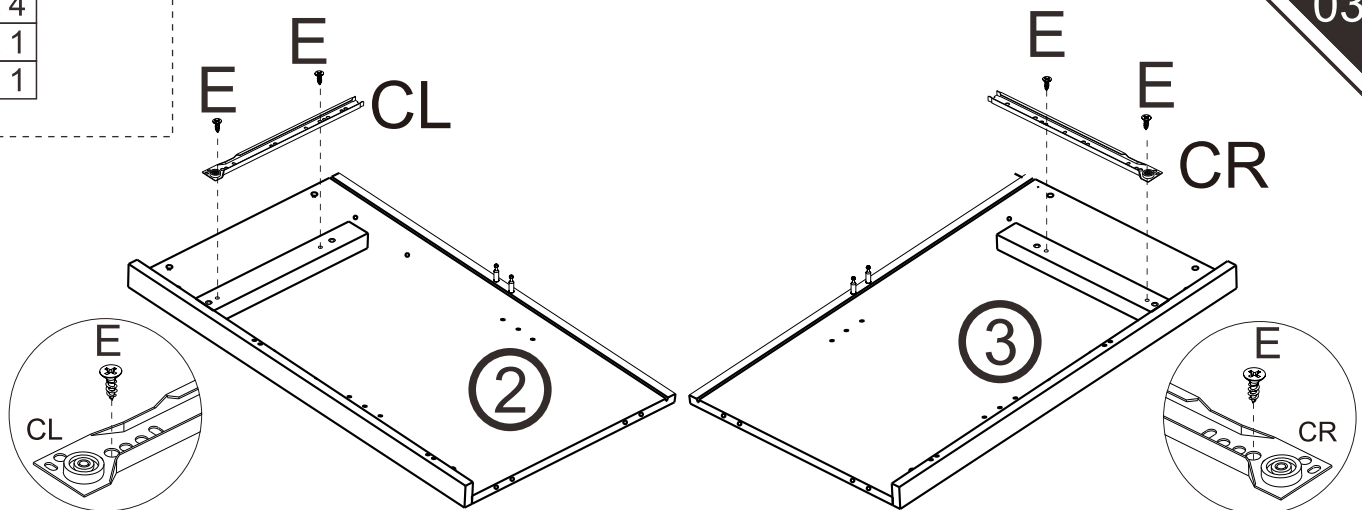

Install part CL to the board(2) by tightening part E.  
Install part CR to the board(3) by tightening part E.

Instale la parte CL en el tablero(2) apretando la parte E.  
Instale la parte CR en el tablero(3) apretando la parte E.

- A x 4
- E x 4
- CL x 1
- CR x 1

Lock part A to the board(4).  
Install part CR to the left of the board(4)  
by tightening part E, and install part CL  
to the right of the board(4) by tightening part E.

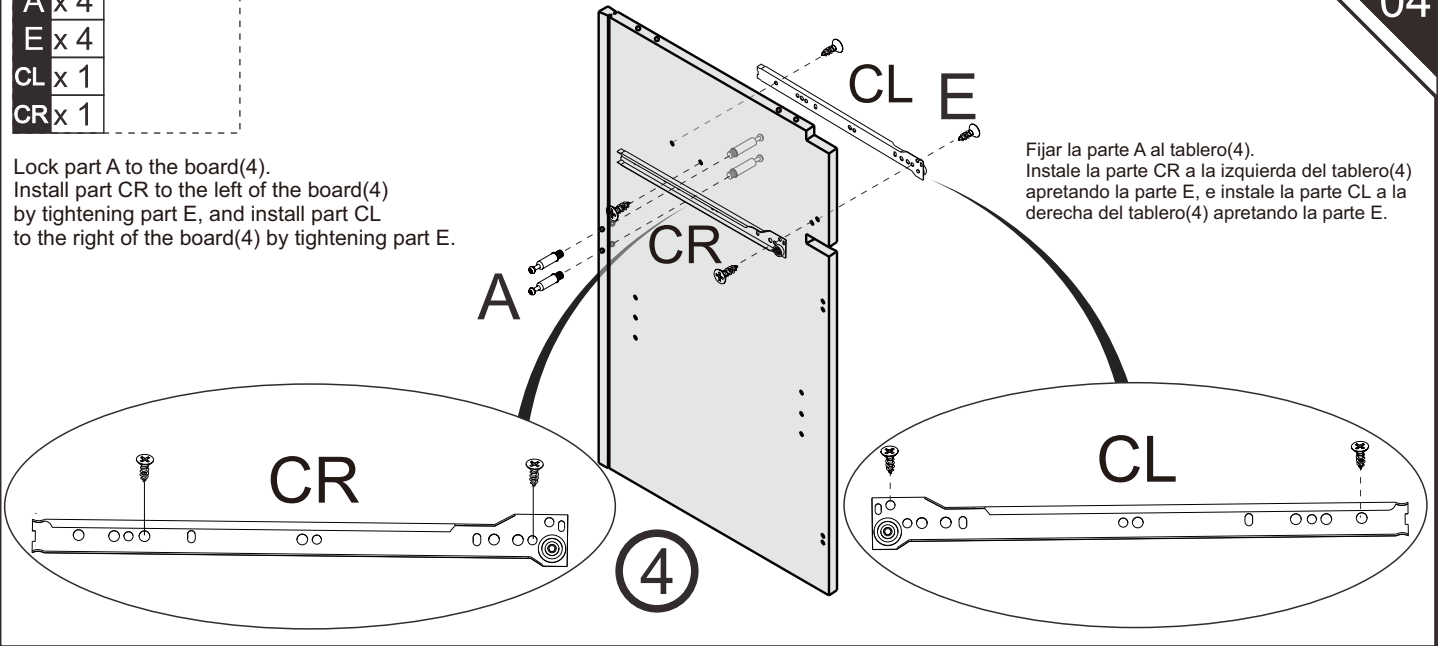

Fijar la parte A al tablero(4).  
Instale la parte CR a la izquierda del tablero(4)  
apretando la parte E, e instale la parte CL a la  
derecha del tablero(4) apretando la parte E.

- B x 4

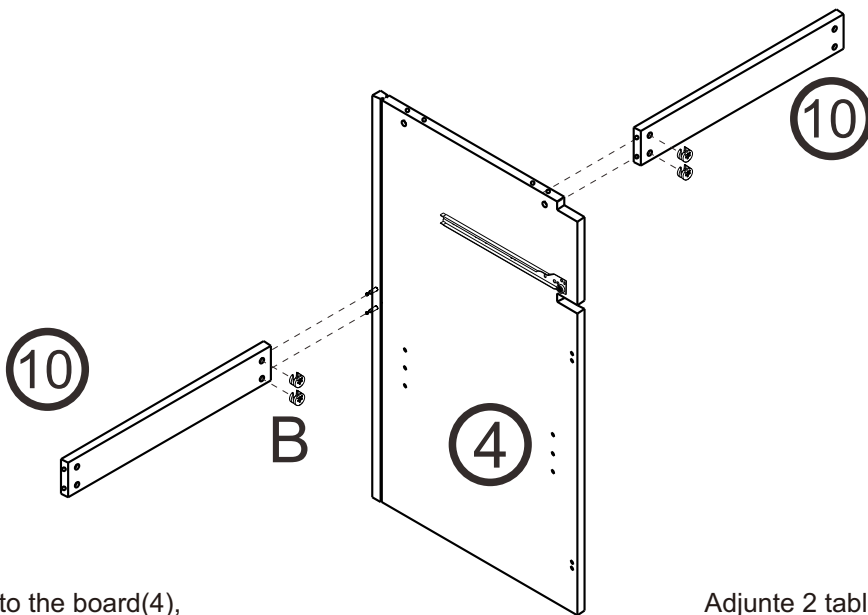
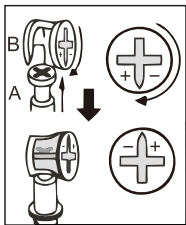

Attach 2 board(10) to the board(4),  
and fix them with part B.

Adjunte 2 tableros(10) al tablero(4),  
y fijelos con la parte B.

- U x 4
- L x 2
- G x 1

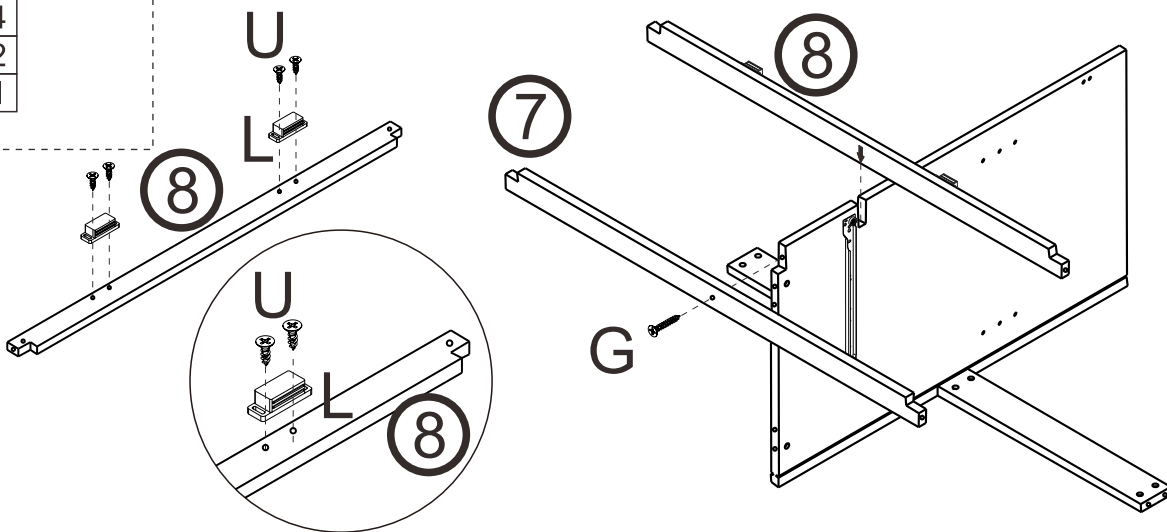

Fix part L on the board(8) by tightening part U.  
Install board (8) to the board(4).  
Fix board(7) on the board(4) by tightening part G.

Fijar la parte L en el tablero(8) apretando la parte U.  
Instale el tablero (8) en el tablero(4).  
Fijar la tabla (7) en la tabla (4) apretando la parte G.

B x 4

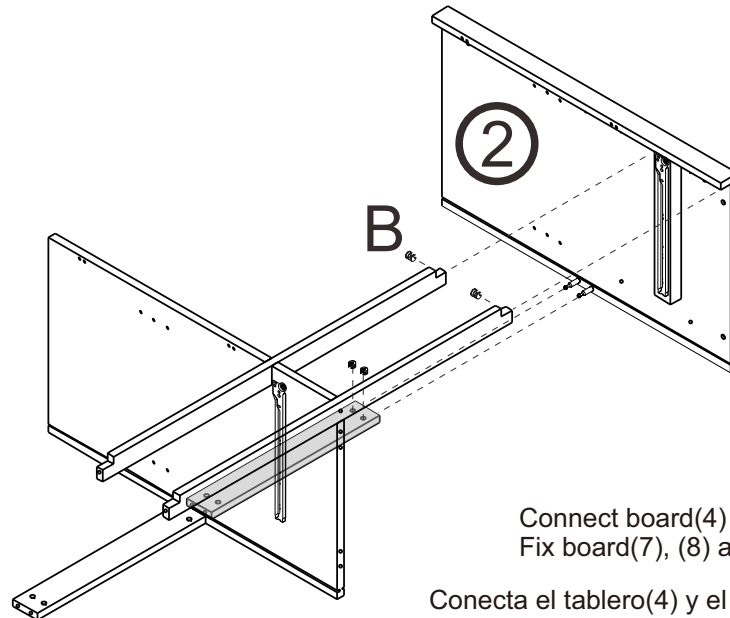
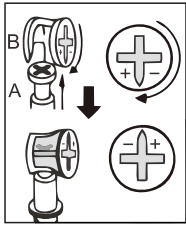

Connect board(4) and board(2);  
Fix board(7), (8) and board(10) with part B.

Conecta el tablero(4) y el tablero(2);  
fija el tablero(7), (8) y el tablero(10) con la parte B.

B x 4

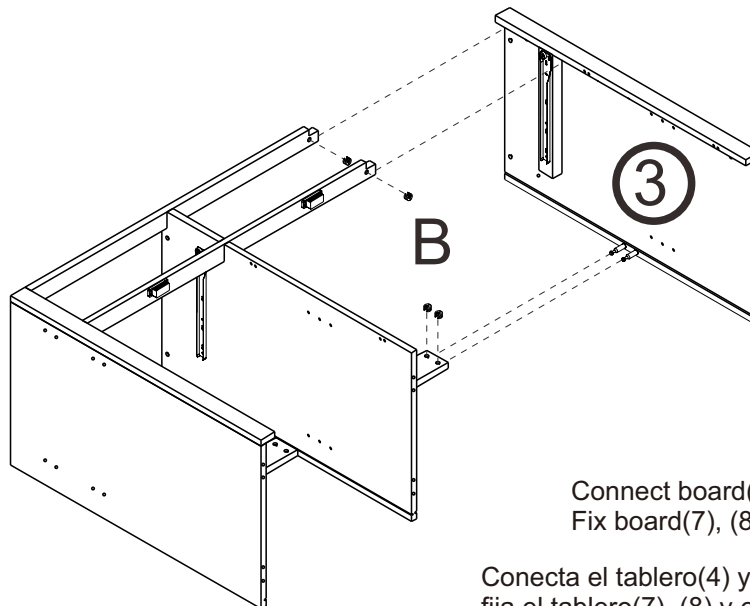
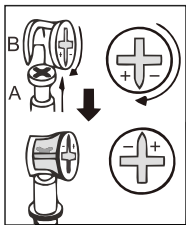

Connect board(4) and board(3);  
Fix board(7), (8) and board(10) with part B.

Conecta el tablero(4) y el tablero(3);  
fija el tablero(7), (8) y el tablero(10) con la parte B.

C x 6

G x 6

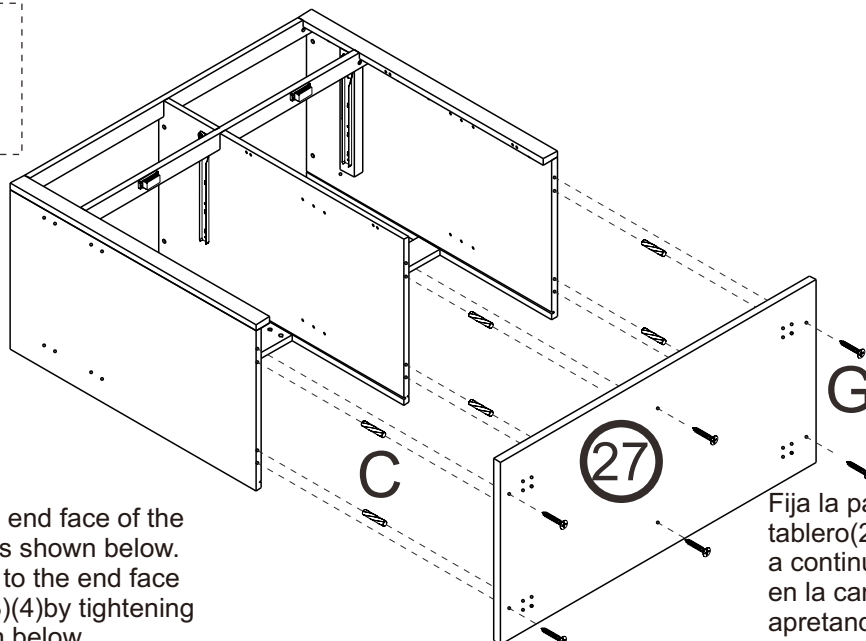

Fix part C on the end face of the  
board(2)(3)(4), as shown below.  
Install board(27) to the end face  
of the board(2)(3)(4) by tightening  
part G, as shown below.

Fija la parte C en la cara final del  
tablero(2)(3)(4), como se muestra  
a continuación. Instale la tabla(27)  
en la cara final de la tabla(2)(3)(4)  
apretando la parte G, como se  
muestra a continuación.

- Q x 2
- R x 2
- V x 16

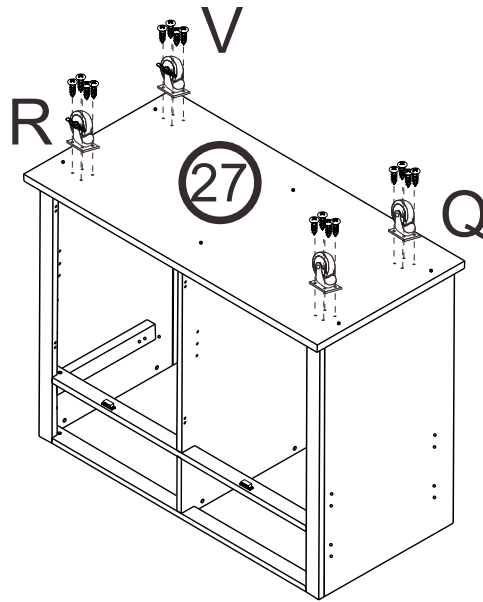

Install the wheels on the board(27) by tightening part V.

Instale las ruedas en el tablero(27) apretando la parte V.

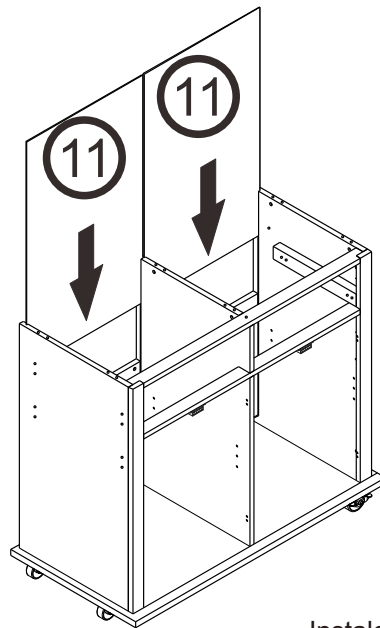

Install 2 board(11) to the main frame.

Instale 2 tableros (11) en el marco principal.

- D x 2
- H x 2
- C x 2

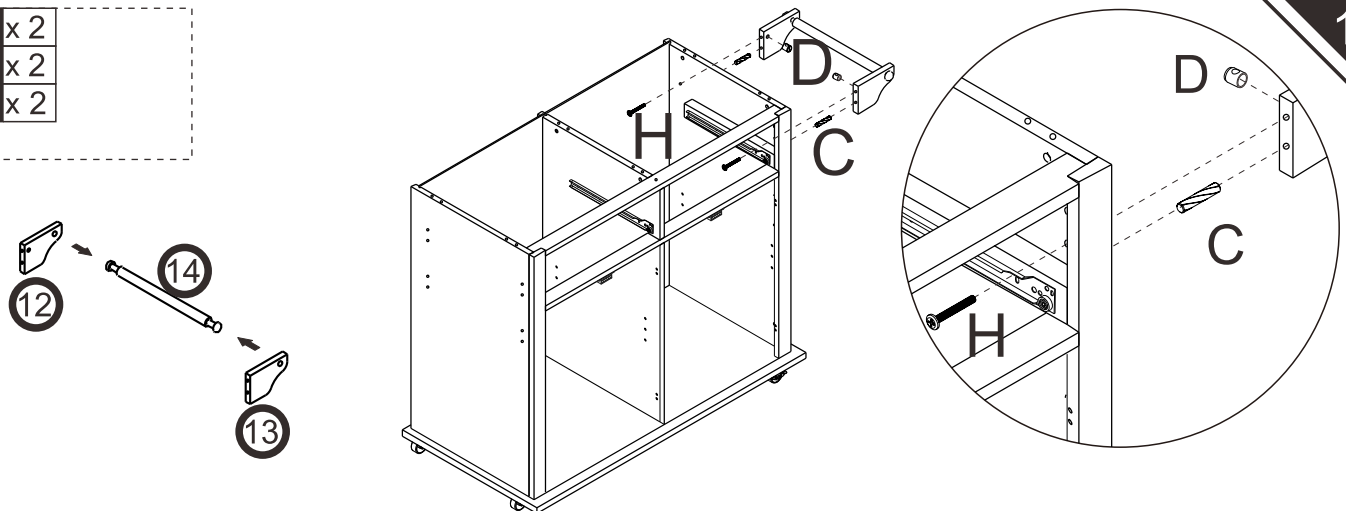

Use part 14 to connect board(12) and board(13).  
Fix part C and part D to the board(12) and board(13), and then connect the board(12)(13) and board(3) by tightening part H.

Utilice la parte 14 para conectar el tablero(12) y el tablero(13).  
Fijar la parte C y la parte D a la placa(12) y a la placa(13), y luego conectar la placa(12)(13) y la placa(3) apretando la parte H.



13

A x 2
B x 2
C x 4

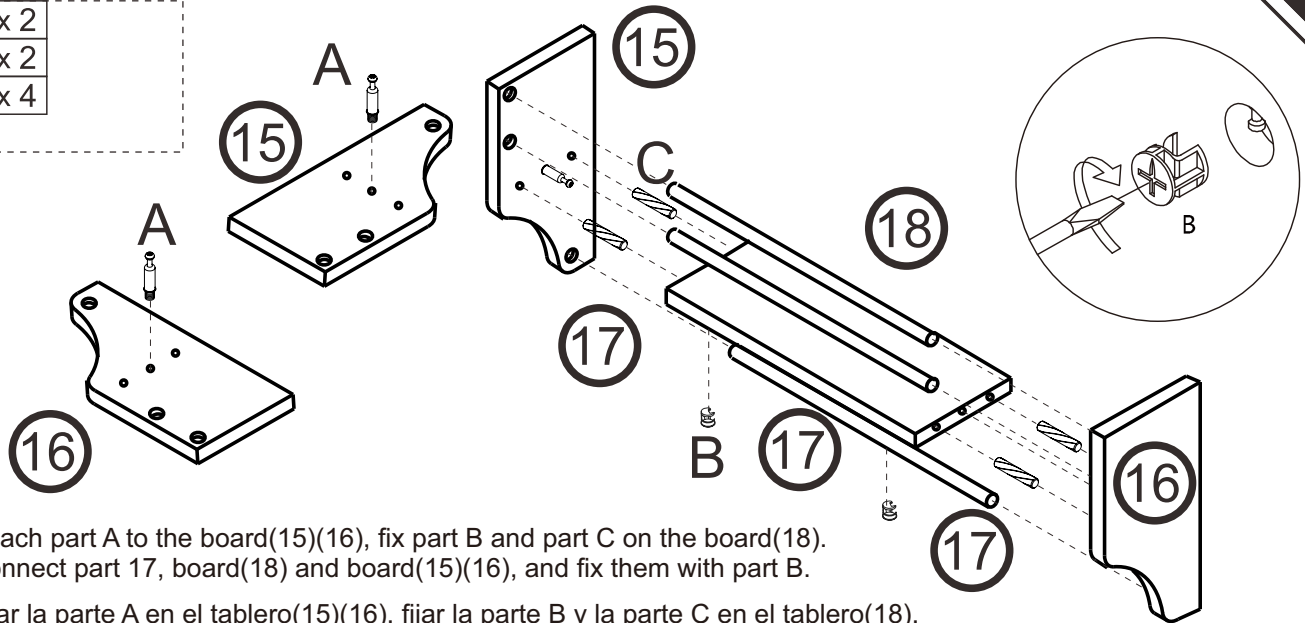

Attach part A to the board(15)(16), fix part B and part C on the board(18).  
Connect part 17, board(18) and board(15)(16), and fix them with part B.

Fijar la parte A en el tablero(15)(16), fijar la parte B y la parte C en el tablero(18).  
Conecta la parte 17, el tablero(18) y el tablero(15)(16), y fíjalos con la parte B.

14

G x 4
C x 4

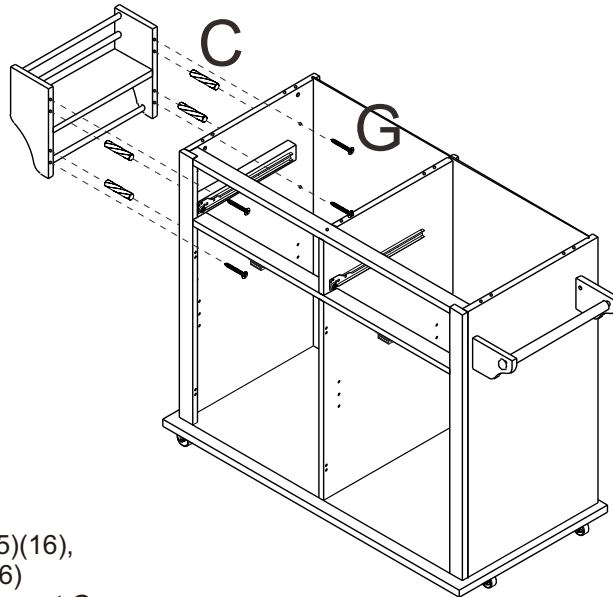

Fix part C on the board(15)(16),  
then connect board(15)(16)  
and board(2) by tightening part G.

Fijar la parte C en la placa(15)(16),  
luego conectar la placa(15)(16)  
y la placa(2) apretando la parte G.

15

A x 6
-------

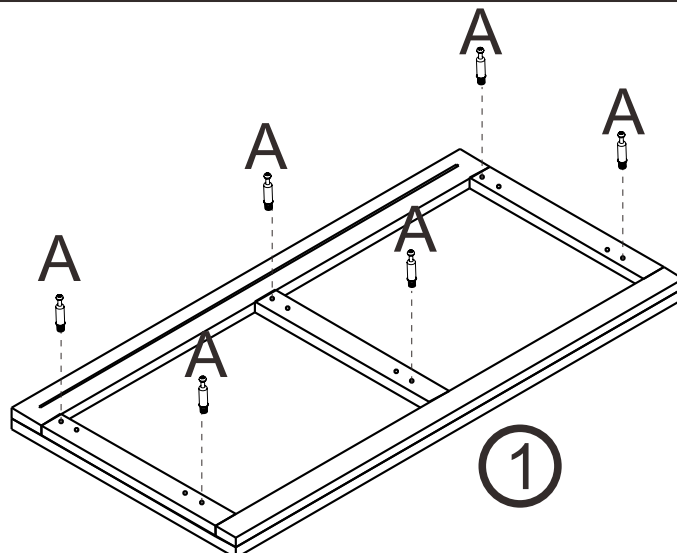

Fix part A on part(1).

Fijar la parte A en la parte (1)..

B x 6  
C x 6

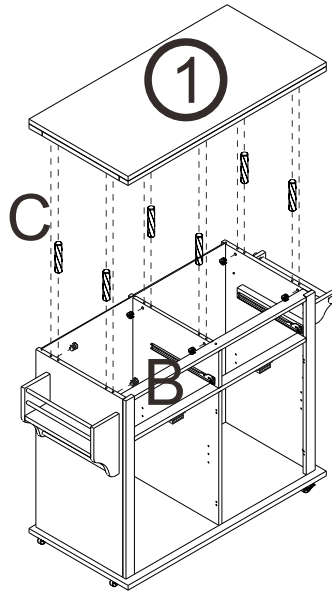

Fix part C on the end face of the board(2)(3)(4), then connect part(1) and the main frame by tightening part B.  
Fijar la parte C en la cara final de la placa(2)(3)(4), luego conectar la parte(1) y el marco principal apretando la parte B.

A x 8  
B x 8  
F x 8  
W x 2  
S x 2

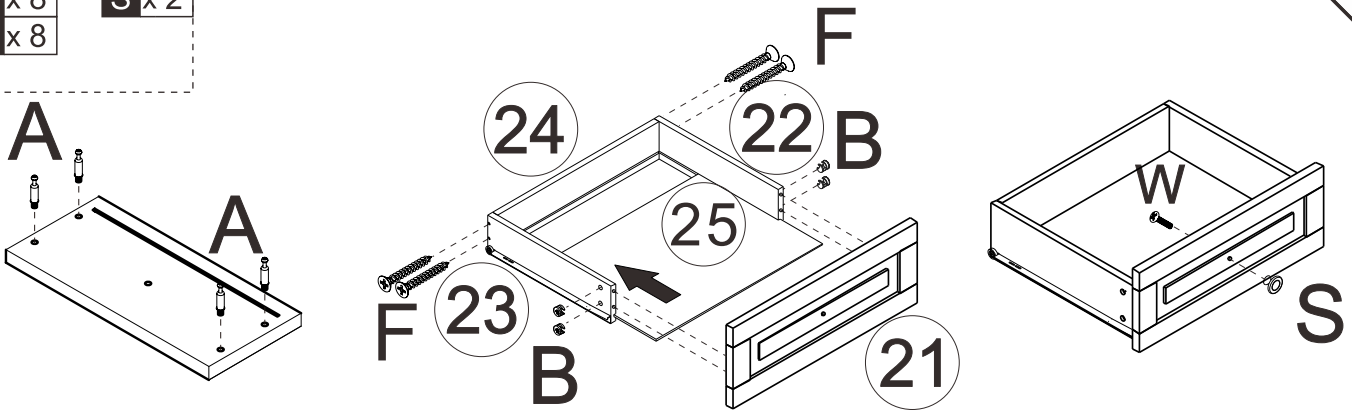

Fix part A on the board(21).  
Connect board(22)(23) and board(24) by tightening part F, then connect board(25) and board(22)(23)(24), then connect board(21) and board(22)(23) by tightening part B. Install the knob on the board(21) by tightening part W.

Fijar la parte A en el tablero(21).  
Conecte la placa(22)(23) y la placa(24) apretando la parte F, luego conecte la placa(25) y la placa(22)(23)(24), luego conecte la placa(21) y la placa(22)(23) apretando la parte B. Instale la perilla en el tablero(21) apretando la parte W.

x2

P x 2  
O x 2  
E x 8

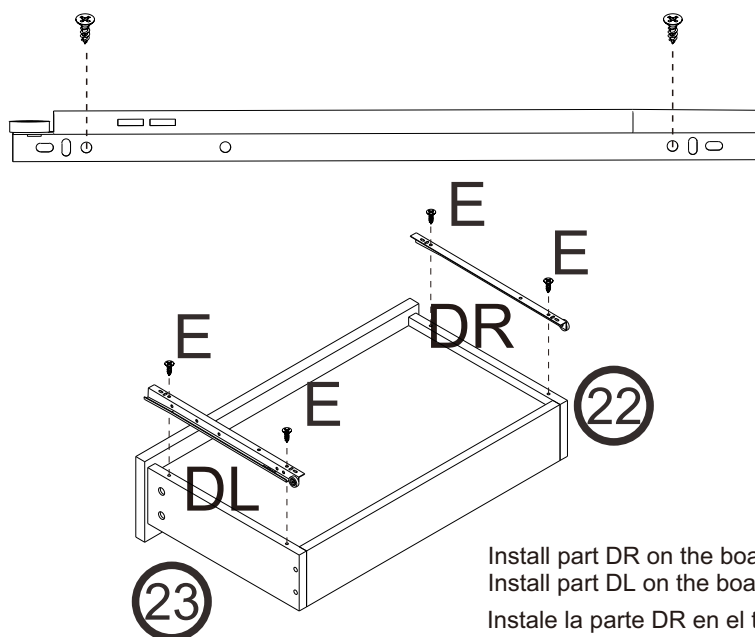

Install part DR on the board(22) by tightening part E.  
Install part DL on the board(23) by tightening part E.  
Instale la parte DR en el tablero(22) apretando la parte E.  
Instale la parte DL en la tabla (23) apretando la parte E.

x2

T x 8

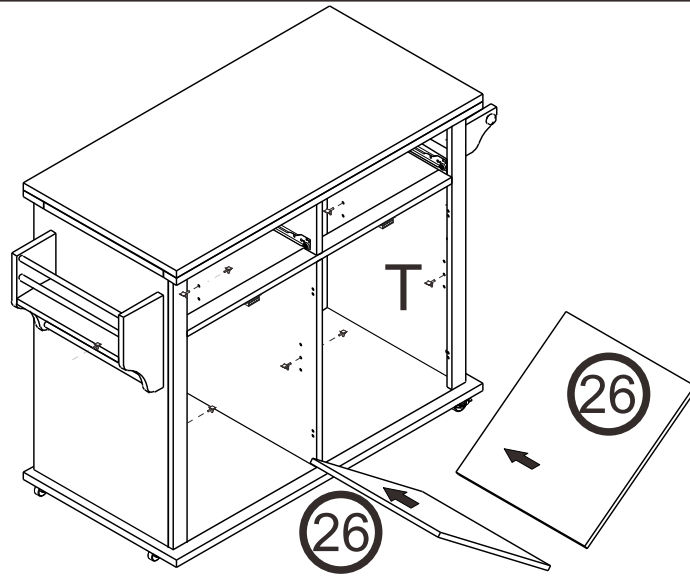

First install part T on the side of the cabinet body, then install the board(26).  
 Primero instale la parte T en el lado del cuerpo del gabinete, luego instale el tablero(26).

E x 4  
 J x 4  
 K x 8  
 X x 16

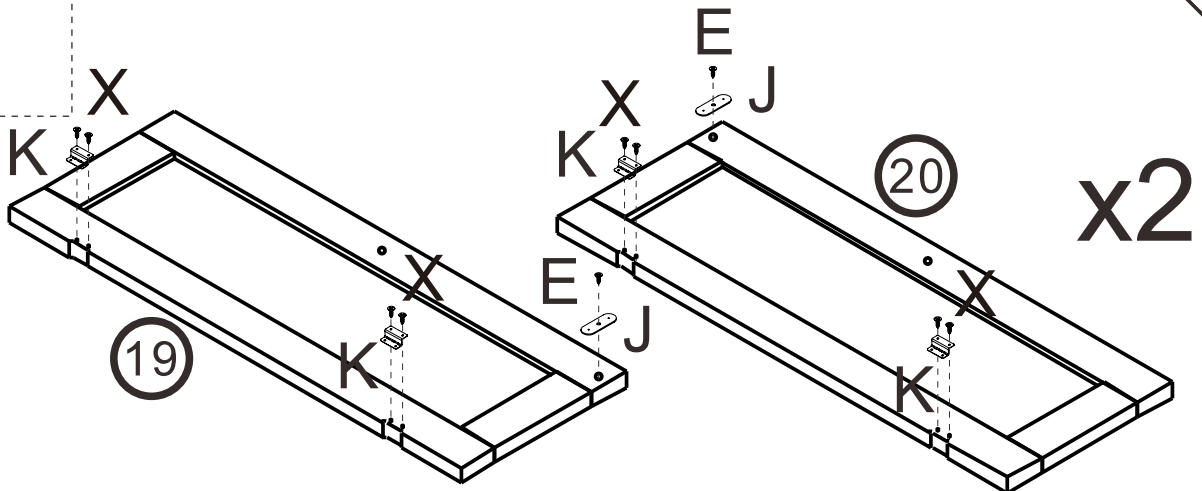

Install part K on part(19) and part(20) by tightening part X.  
 Install part J on part(19) and part(20) by tightening part E.  
 Instale la parte K en la parte(19) y la parte(20) apretando la parte X.  
 Instale la parte J en la parte(19) y la parte(20) apretando la parte E.

X x 8  
 S x 2  
 I x 2

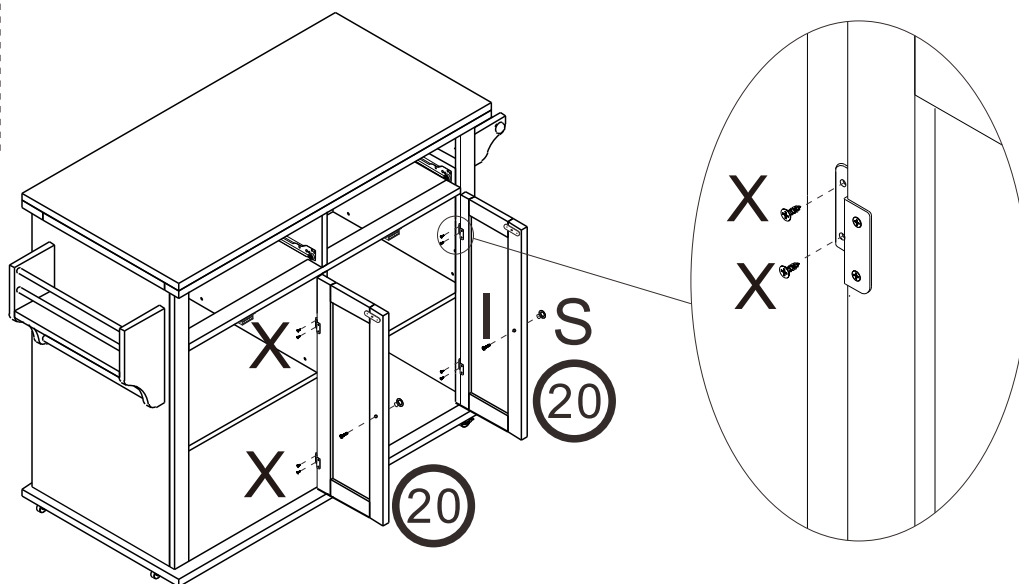

Install part S on board(20) by tightening part I, then install the board(20) on the cabinet by tightening part X.

Instale la parte S en la placa(20) apretando la parte I, y luego instale la placa(20) en el gabinete apretando la parte X.

- X x 8
- S x 2
- I x 2

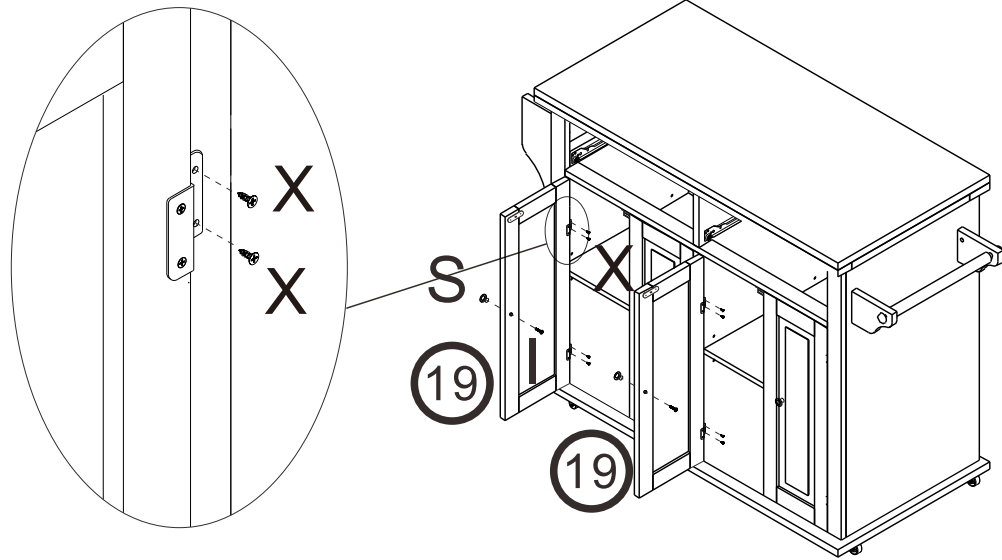

Install part S on board(19) by tightening part I, then install the board(19) on the cabinet by tightening part X.

Instale la parte S en la placa(19) apretando la parte I, y luego instale la placa(19) en el armario apretando la parte X.

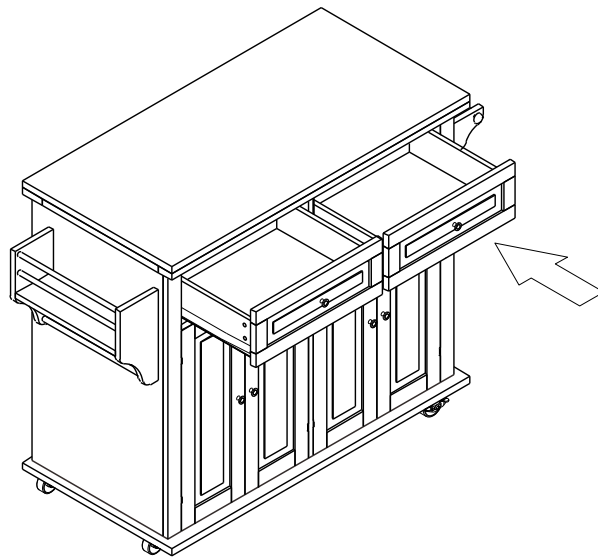

Attach the installed drawers to the cabinet  
Installation completed

Ata los cajones instalados al gabinete.  
Instalación completada

