

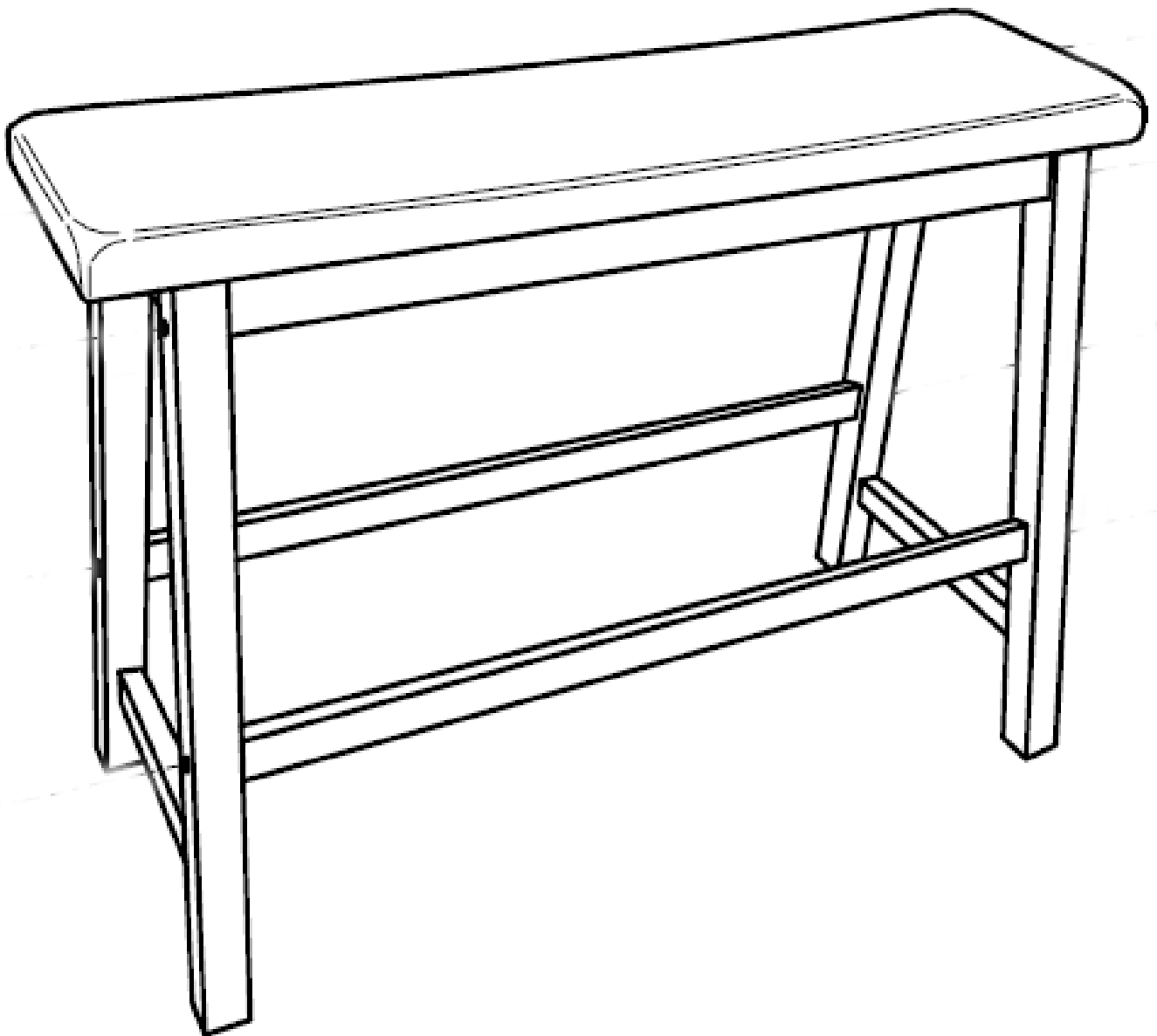

Assembly Instructions

Caution: You must read this before you proceed.



Bench

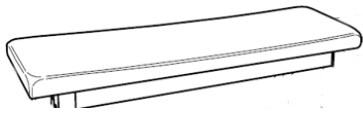

Parts List

Part NO.	Picture	Description	QTY
A		Bench Seat	1 PC
B		Leg Frame	2 PCS
C		Bench Rail	2 PCS

Hardware

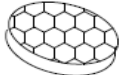
Label	Picture	Description	QTY
D		Screw(M7*50MM)	8 PCS
E		Wood Button	8 PCS
F		Allen Key	1 PC
G		Foam Pad	4 PCS

Assembly Preparation

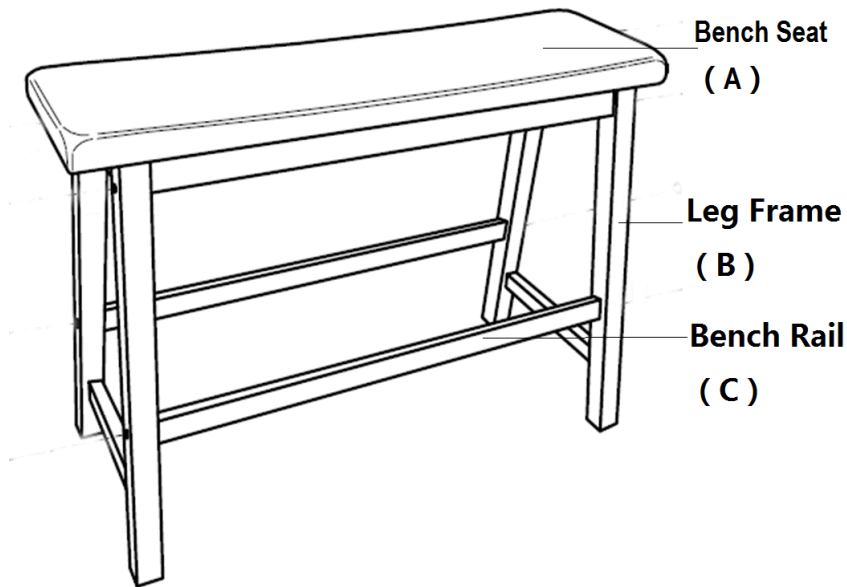

This Bench has multiple parts and may require up to 30 minutes to assemble. To give you an overview of the Bench parts, the above picture is to help you put the various Bench parts into perspective.

Please read through the instructions herebelow to familiarise yourself with the parts and steps before assembly.

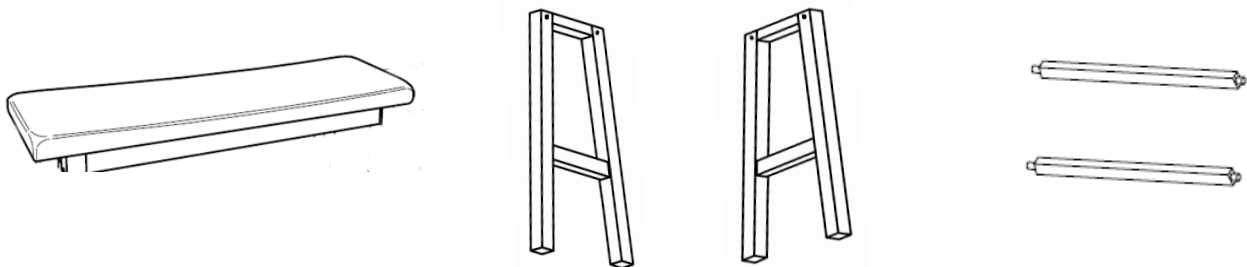

- Read instructions, cover to cover-



- Have 2 adults on hand for assembly-



- Do not assemble on flooring or carpet-



- Assemble on a clean non-marring surface (packing foam)-



- Save all packaging until finished-

Assembly Steps

Step 1

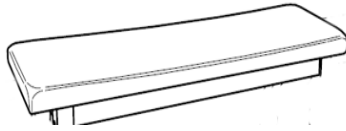

A. Bench Seat

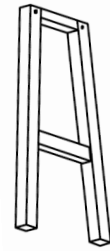

B. Leg Frame

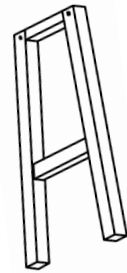

B. Leg Frame

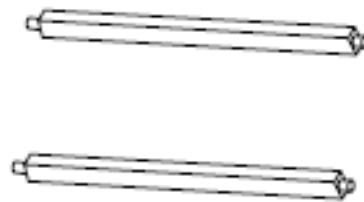

C. Bench Rail

Place the Bench Seat(A)& Leg Frames(B)&Bench Rail (C) on a clean, non-marring surface. Remove the Seat Base Cover from the underside of the Bench Seat(A) and take out all of the Parts and Hardware.

Step 2

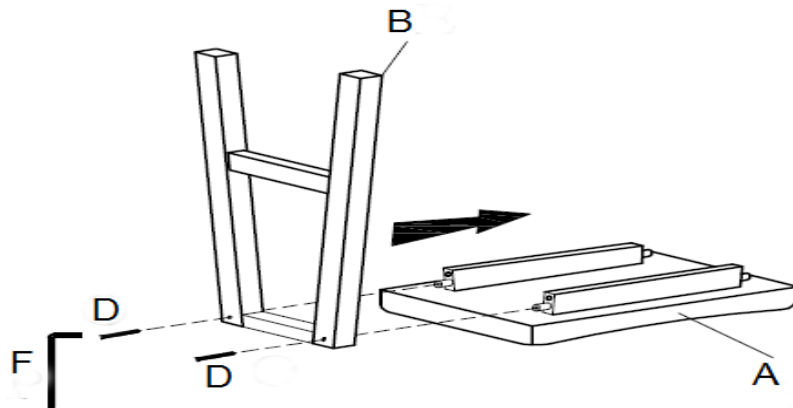

Put the Bench Seat(A) onto a flat table top.
Slide the Leg Frame(B) into the bottom Bench Seat dowls.
Align and attach Leg Frame using Screws(D) with Allen Key(F)

Caution : At this stage, LOOSELY FASTEN these bolts

Step 3

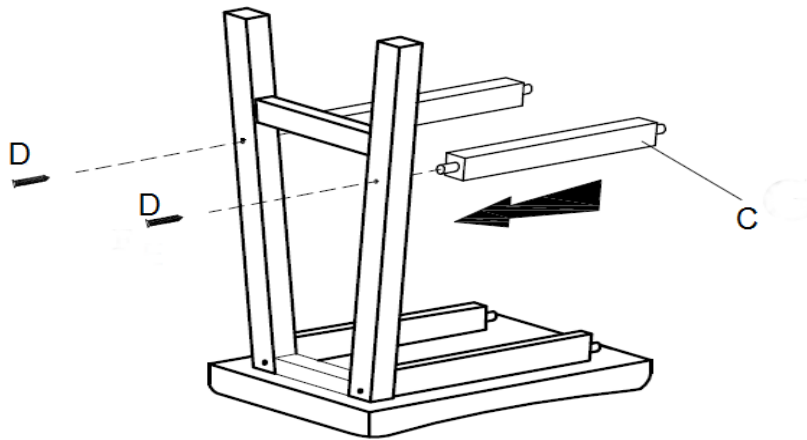

Insert Bench Rail(C) into the Leg Frame(B) as shown above.
Then, attach using Screw(D) with Allen Key(F).

Caution : At this stage, LOOSELY FASTEN these bolts

Step 3

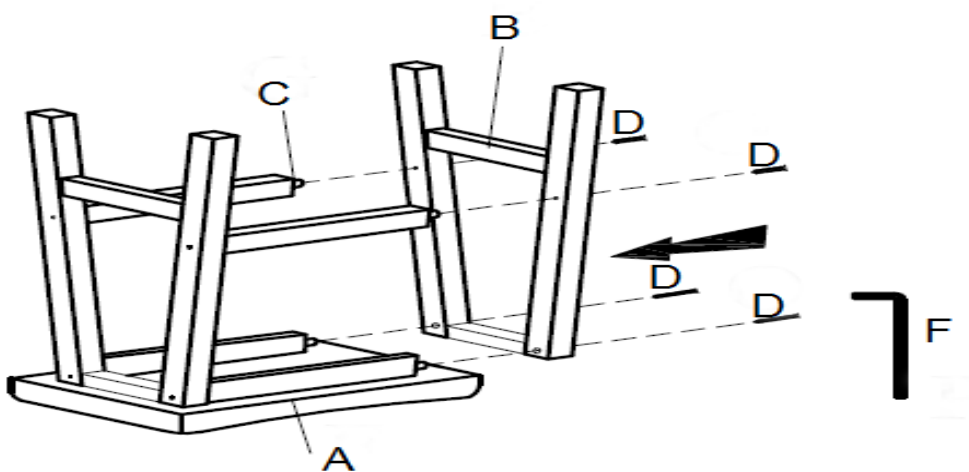

Slide the Leg Frame(B) into the bottom of Bench Seat dowls and Bench Rails(C).
Secure using Screws with Allen Key(F),

Proceed to tighten all the bolts

Step 4

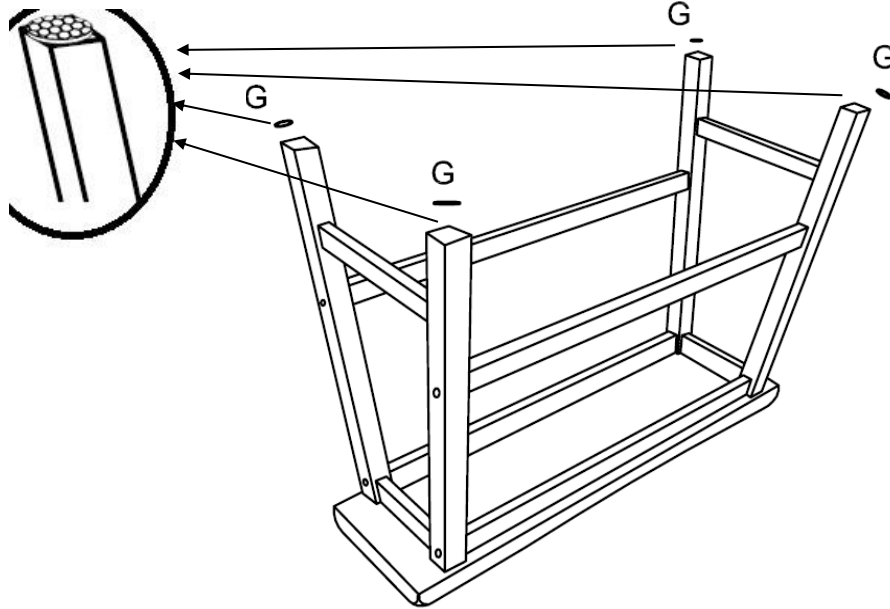

Adhere the Foam Pads(G) under the Legs.

Step 5

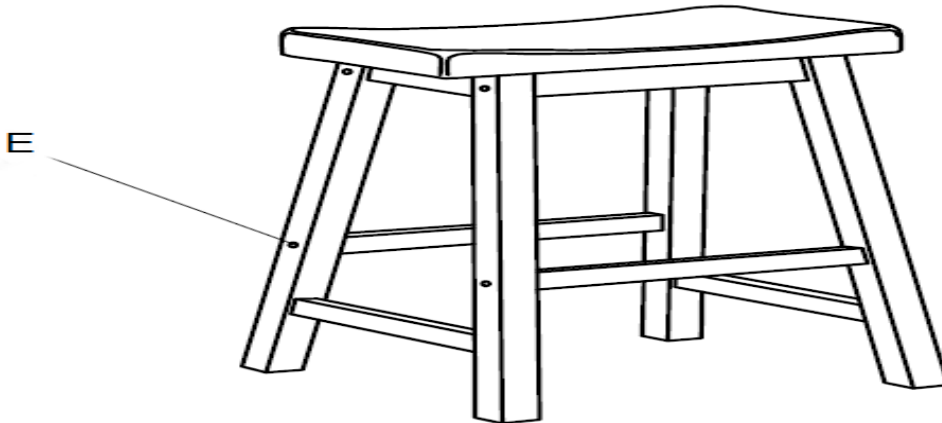

Stand the Stool rightside up.
Insert the wood button(E) into the leg support rail screw Hole
Your Spindle Back Chair is ready for use.

Care & Maintenance



- Do not put hot items directly on furniture surface



- Do not clean furniture with harsh cleansers or polish.



- Do not place furniture under direct sunlight.



- Do not place furniture near heating or cooling vents.



- Do not write on furniture without a padded barrier to protect the surface.



- Do not place furniture outside . For indoor use only .



- Not for commercial use. For residential use only .



- Stains may be removed with mild soap solution and damp cloth.



- Children should not climb or jump on the furniture.



- Dust and pick-up spills using a clean, non-colored, lint-free cloth .