

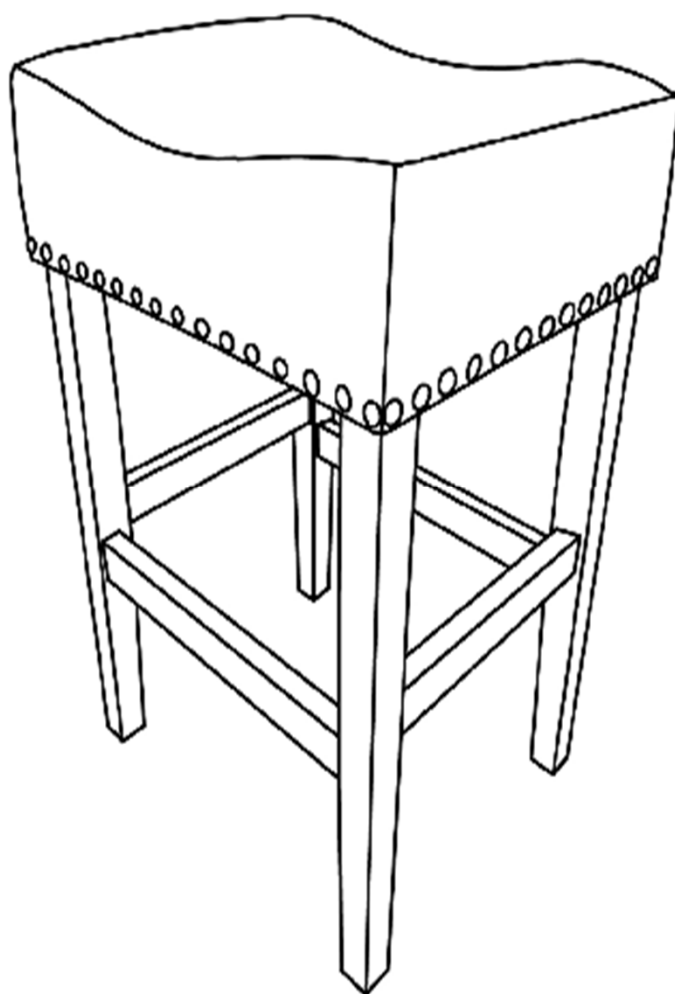

# Assembly Instructions

Caution: You must read this before you proceed.



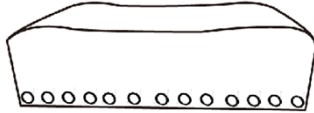
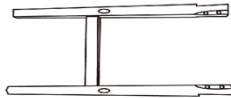

## Bar Stool



## Parts List

Part NO.	Picture	Description	QTY
A		Bar Stool Seat	1 PC
B		'H'Leg Frame	2 PCS
C		Side Rails	2 PCS

## Hardware

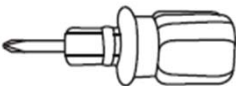
Label	Picture	Description	QTY
1		50mm Long Bolt	9 PCS
2		Flat Washer Ring	9 PCS
3		Spring Washer Ring	9 PCS
4		Allen Key	1 PC
5		Screw (4*50mm )	5 PCS
6		Screwdriver	1 PC

# Assembly Preparation

Before Beginning Assembly:

Unpack and place all parts for clear visibility

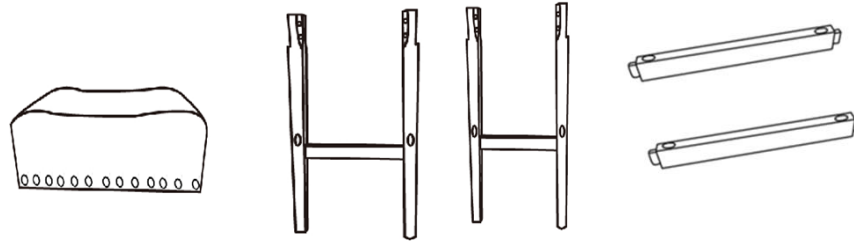

Pack A for assembling the Leg Frame(B) to the Chair Seat(A)

9pc of 50mm Long Bolts + 9pc of Flat Washer Ring + 9pc of Spring Washer + one Allen Key



Pack B for assembling the Side Rails(C) to the Leg Frame(B)

1pc of Screwdriver + 5pcs  $\varnothing 4*50\text{mm}$  Screws



- Read instructions, cover to cover-



- Have 2 adults on hand for assembly-



- Do not assemble on flooring or carpet-



- Assemble on a clean non-marring surface (packing foam)-



- Save all packaging until finished-

# Assembly Steps

## Step 1

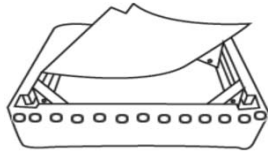

A. Bar Stool Seat

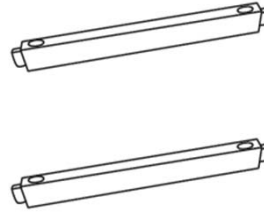

C. Side Rails



B. 'H' Leg Frames-when assembling, the BOLT points must be INWARD facing.

Place the Bar Stool Seat(A) onto a soft surface to avoid any scratches or damages to the product.  
REMOVE the Seat Base Cover from the underside of the Bar Stool Seat (A), take out the Side Rails(C) and hardware.

## Step 2

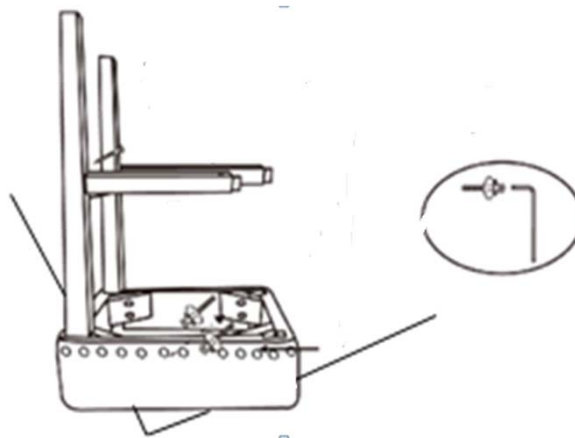

Insert the 'H'Frame Legs(B)into the Seat Frame (A)use "PACK A"to connect these.

Insert the Side Rail(C)with the bottom side up into the Leg Frame(B).

**WARNING !! DO NOT OVER TIGHTEN. OVER TIGHTENING COULD LEAD TO DAMAGE OF THE PRODUCT. TIGHTEN ONLY UNTIL SECURE.**

## Assembly Steps

### Step 3

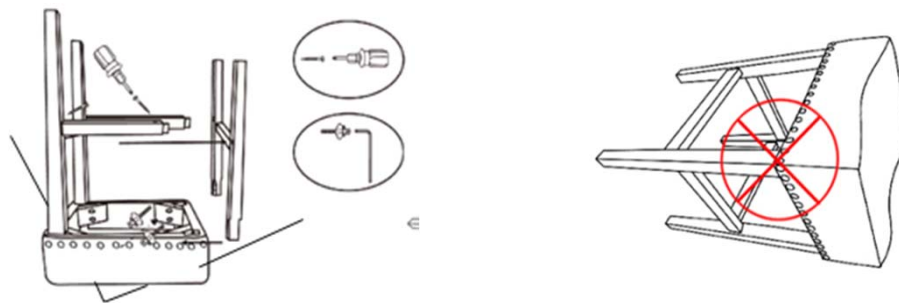

Next, place the chair onto the side of a table as seen in Picture 1.

You will now have the chair bottom and legs facing skywards.

Insert the other'H'Leg Frame (B)into the Seat Frame(A).

Then insert the Side Rail(C)into the Leg Frame(B).

The mounting points on these Side Rails shall be floor facing, after fully assembled.

**WARNING!! DO NOT POSITION THE FRONT LEG AS SHOWN IN PICTURE 2 .**

**THIS PICTURE SHOWS THE CHAIR BACK STAYS AGAINST THE GROUND and THE LEGS HORIZONTAL IN MIDAIR.**

Use "PACK A" to assemble the "H" Leg Frame(B) to the Seat Frame (A),

Then use "PACK B" to hold the Side Rails to each leg.

**WARNING!! DO NOT OVER TIGHTEN. OVER TIGHTENING COULD LEAD TO DAMAGE OF THE PRODUCT. TIGHTEN ONLY UNTIL SECURE AND STABLE.**

#### Step 4

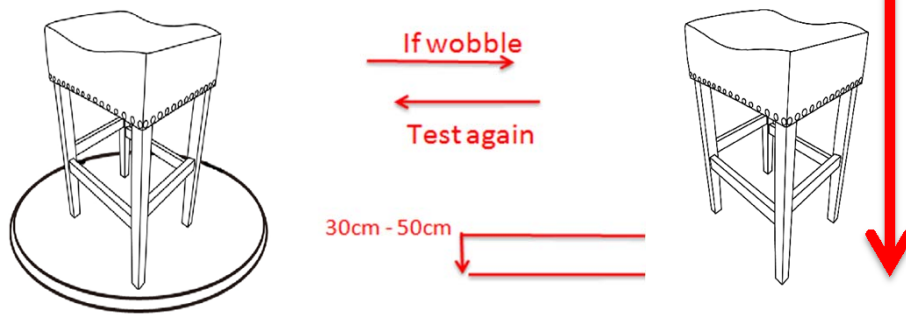

Place the chair on a **LEVEL SURFACE** to see if it wobbles. If it wobbles, lift the chair to some 30cm to 50cm height from the ground.

Keep your feet and toes well away from the drop zone.

Drop the chair freely and vertically with the four legs, hitting the ground, at the same time.

This Drop Test will help to ensure that all the bolts and gaps to all reach full alignment status.

Test again for evenness on a **LEVEL SURFACE**.

If no wobbles found, **proceed to tighten all the bolts.**

**CAUTION** : When tightening these bolts, tighten sequentially.

**DO NOT** tighten any screw fully and then towards the next one.

This would cause the frame to warp.

If there is still wobbles, loosen the bolts and execute this same drop tests.

**WARNING!! IF CHAIR IS NOT STABLE , IT COULD LEAD TO DAMAGING THE PRODUCT.**

#### Step 5

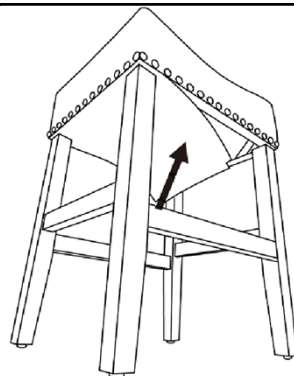

Place the Seat Base Cover back underneath the chair seat (as shown in picture) from where it was originally removed from.

Smooth down the 4 velcro edges with your hand, The bar stool is now ready for use.

## Care & Maintenance



• Do not put hot items directly on furniture surface.



• Do not clean furniture with harsh cleansers or polish.



• Do not place furniture under direct sunlight.



• Do not place furniture near heating or cooling vents.



• Do not write on furniture without a padded barrier to protect the surface.



• Do not place furniture outside. For indoor use only.



• Not for commercial use. For residential use only.



• Stains may be removed with mild soap solution and damp cloth.



• Dust and pick-up spills using a clean, non-colored, lint-free cloth.