

ASSEMBLY INSTRUCTIONS

W697121846

W697121847

W697121848

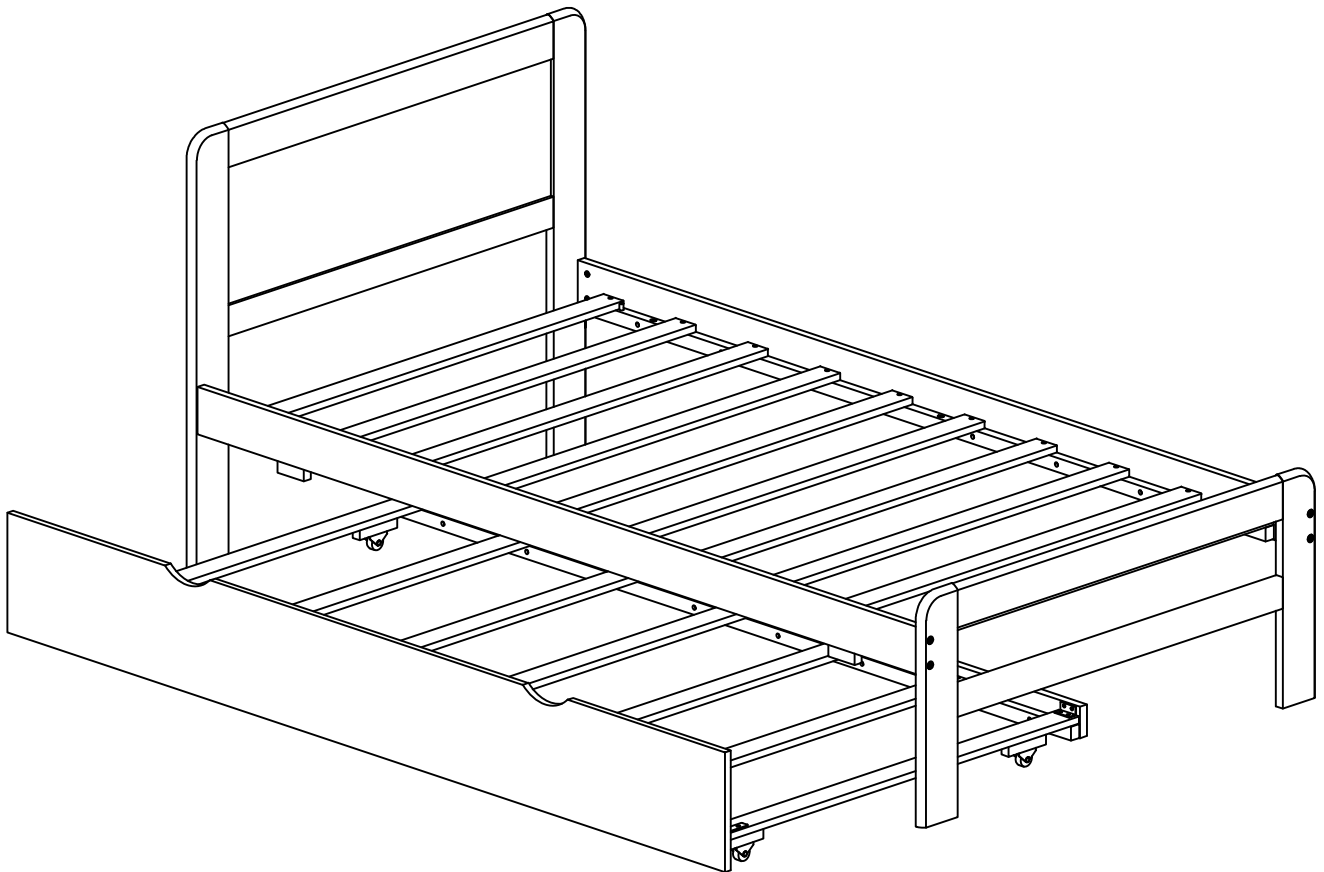





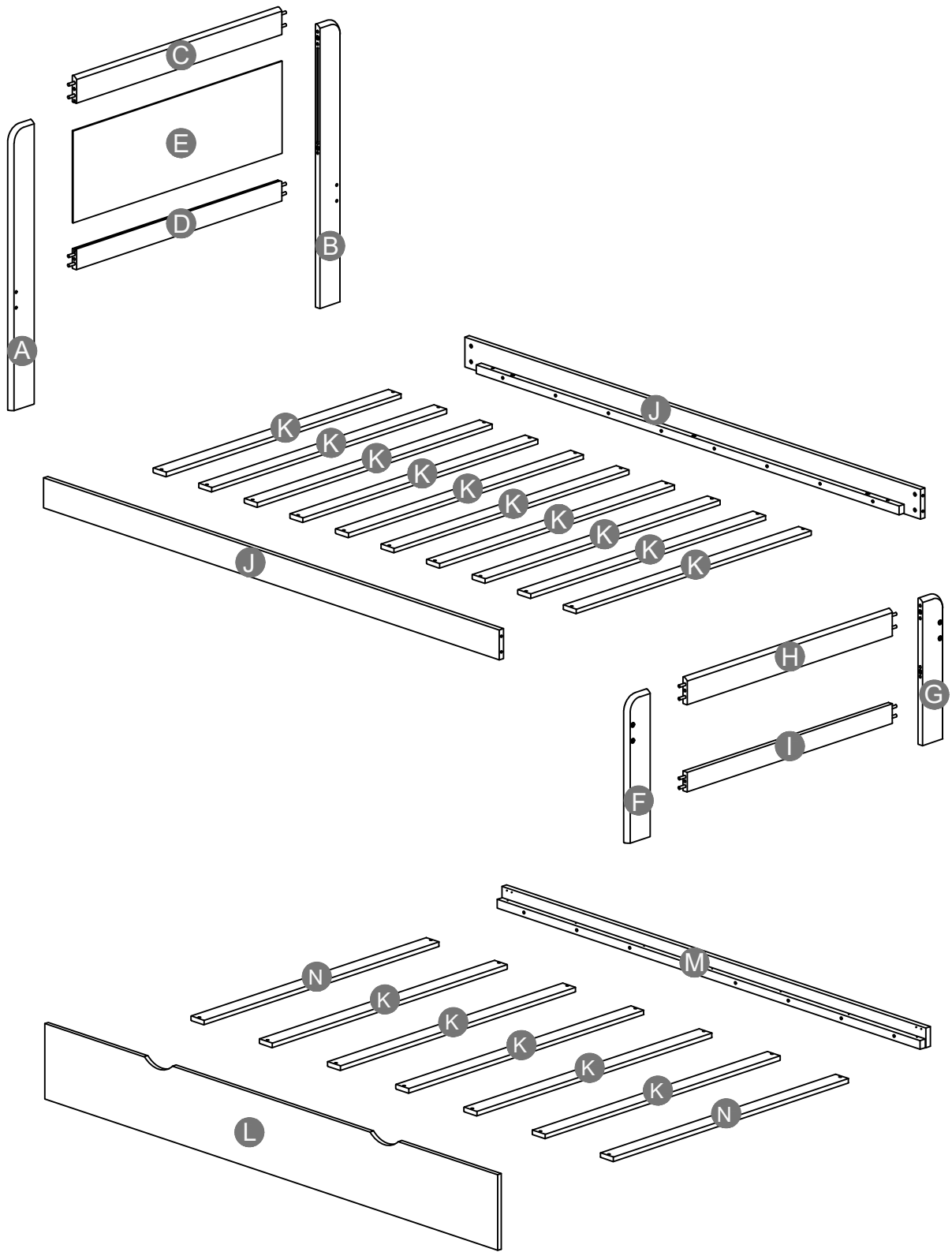

YX7102

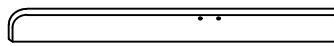
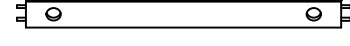
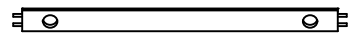

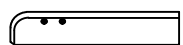
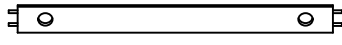
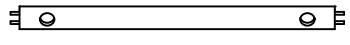

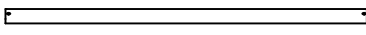
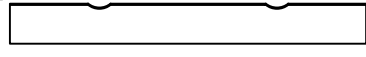

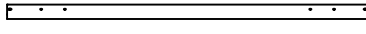

Detail View

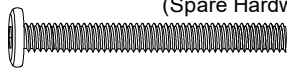

Part List

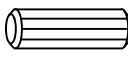
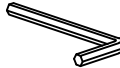
| | | |
|---|---|---|
| <p>A</p>  <p>Headboard leg (Left)-1pc</p> | <p>B</p>  <p>Headboard leg (Right)-1pc</p> | <p>C</p>  <p>Horizontal upper bar HB-1pc</p> |
| <p>D</p>  <p>Horizontal bottom bar HB-1pc</p> | <p>E</p>  <p>Headboard panel-1pc</p> | <p>F</p>  <p>Footboard leg (Left)-1pc</p> |
| <p>G</p>  <p>Footboard leg (Right)-1pc</p> | <p>H</p>  <p>Horizontal upper bar FB-1pc</p> | <p>I</p>  <p>Horizontal bottom bar FB-1pc</p> |
| <p>J</p>  <p>Side rail-2pcs</p> | <p>K</p>  <p>Slat-10pcs + Trundle Slat-5pcs</p> | <p>L</p>  <p>Trundle front panel - 1pc</p> |
| <p>M</p>  <p>Trundle back panel-1pc</p> | <p>N</p>  <p>Trundle Slat-2pcs</p> | |

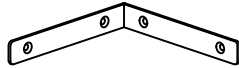
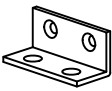
Hardware List

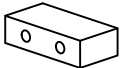
| | | |
|---|---|--|
| 1  (Spare Hardware-1pc) 1/4"*9.8*5mm Hexagon Nut (9pcs) | 2  (Spare Hardware-1pc) 1/4"*89mm All thread bolt(9pcs) | 3  (Spare Hardware-1pc) Ø8-28*14*7mm Curved washer(9pcs) |
| 4  (Spare Hardware-1pc) (Ø12)1/4"*55mm Hex-Head bolts (11pcs) | 5  (Spare Hardware-1pc) 1/4"*15mm Horizontal-Hole bolts(9pcs) | 6  (Spare Hardware-4pcs) Ø4*25mm Wood screws (46 pcs) |
| 7  Ø8*25mm Wood dowel (6pcs) | 8  (1/4")4*60mm Allen key (1pc) | 9  88*22*2mm Wrench (1pc) |
| 10  120*120*18*2mm Metal bracket (2pcs) | 11  35*18*18*2mm Metal bracket (2pcs) | 12  (Spare Hardware-2pcs) Ø4*12mm Wood screws (18 pcs) |
| 13  100*62*19mm Wheels (4pcs) | 14  70*38*19mm Stopper (2pcs) | |

ASSEMBLY TOOLS REQUIRED (NOT INCLUDED)

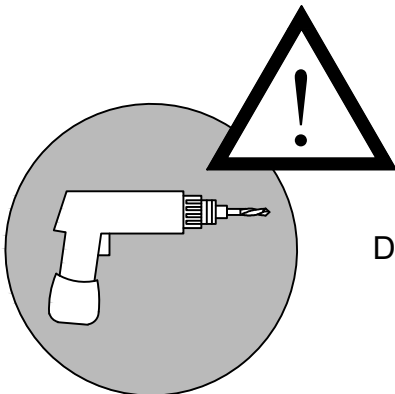
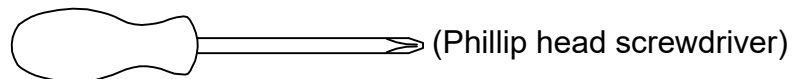

DO NOT USE POWER TOOLS TO ASSEMBLE THIS PRODUCT !

Remark: We recommend you assemble your bed in the flat ground.

STEP 1:

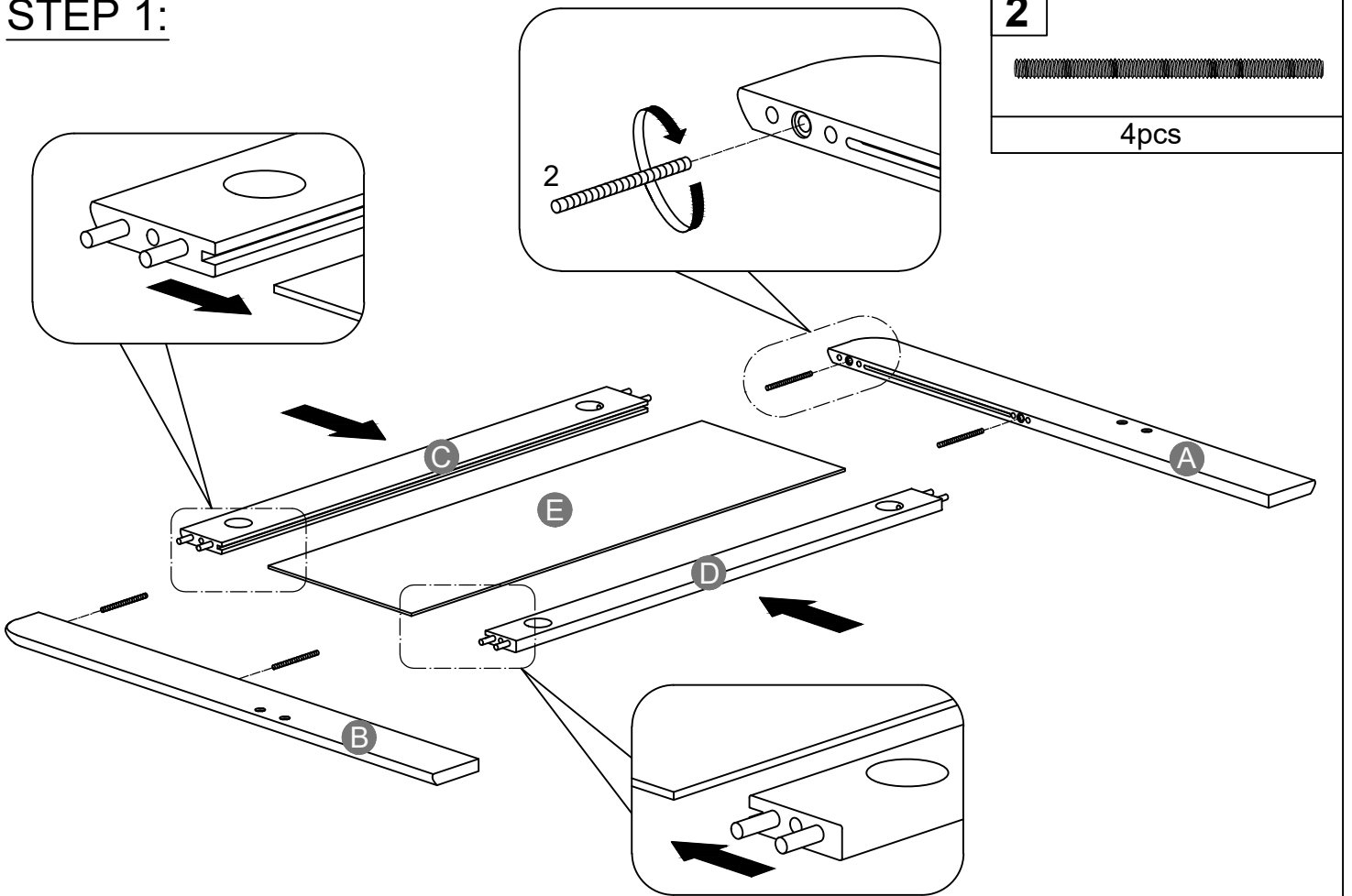

STEP 2:

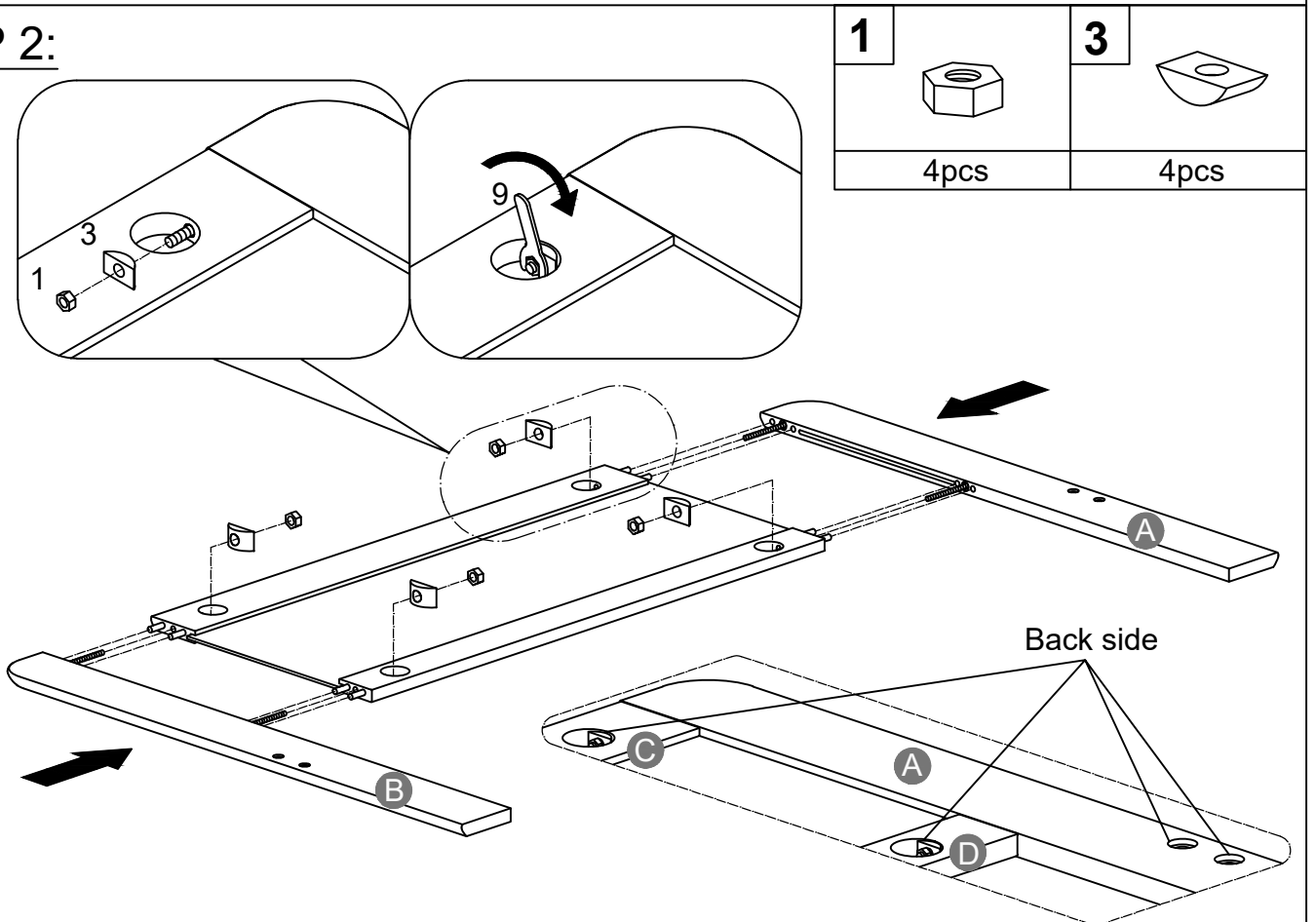

Make sure bars A,B,C,D are connected together on the same side (front-front, back-back)

STEP 3:

2



4pcs

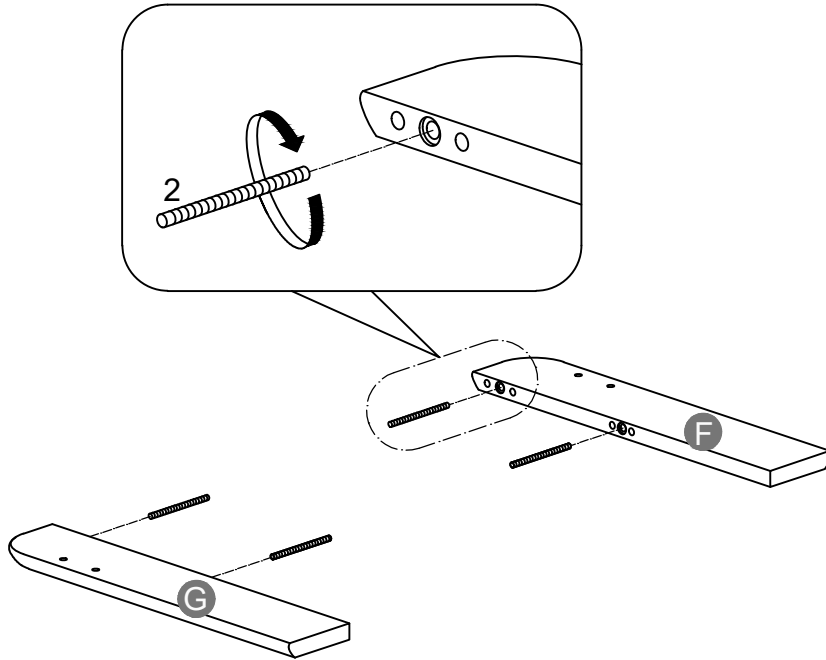

STEP 4:

1



4pcs

3



4pcs

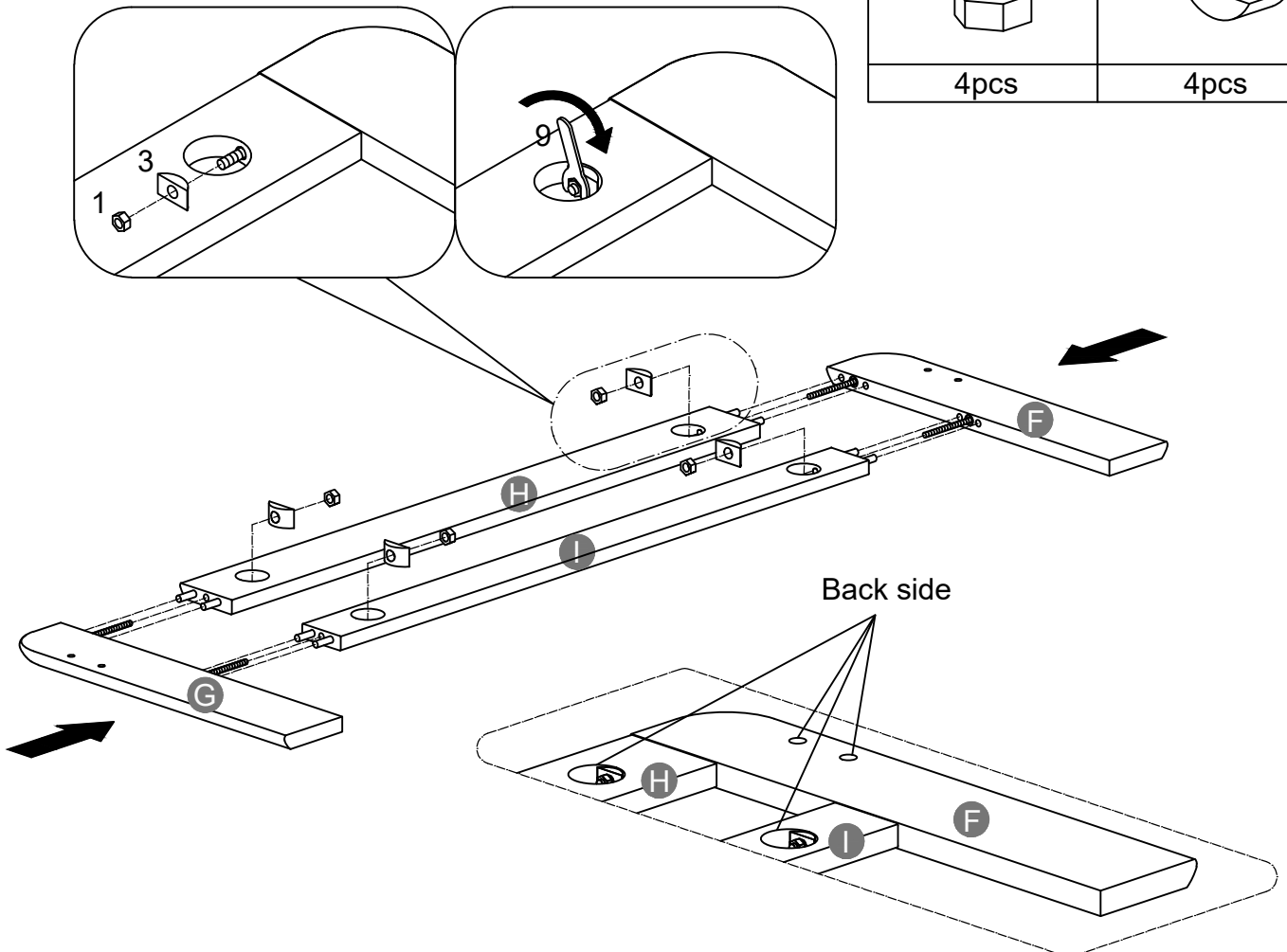

Make sure bars A,B,C,D are connected together on the same side (front-front, back-back)

STEP 5:

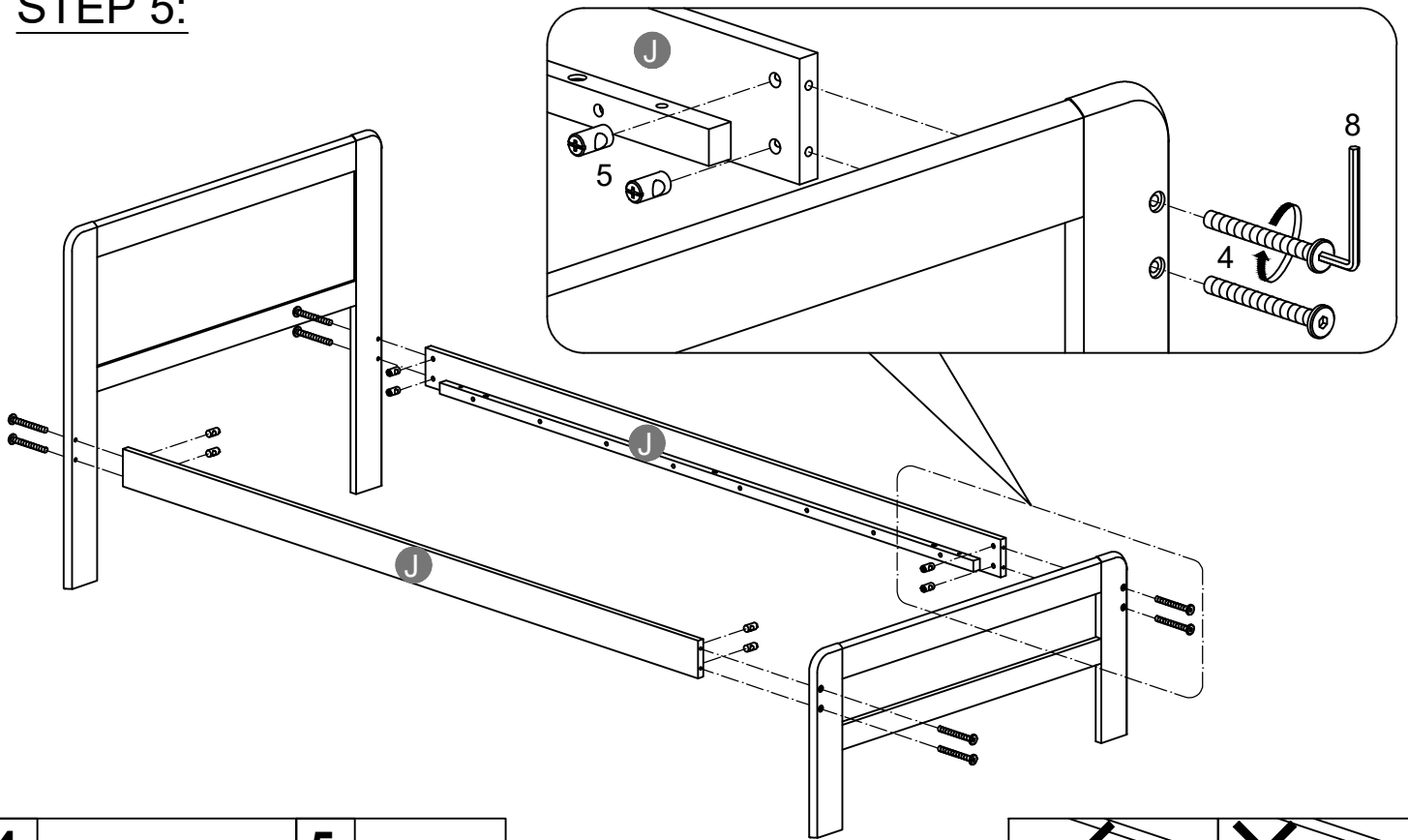

4

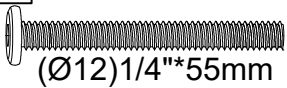

8pcs

5



8pcs

Note: Part 5 will face up with the "x" mark on it, otherwise it cannot be tightened

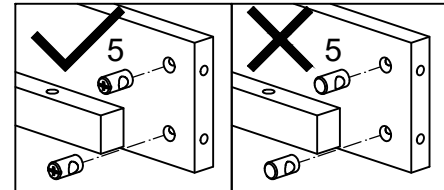

STEP 6:

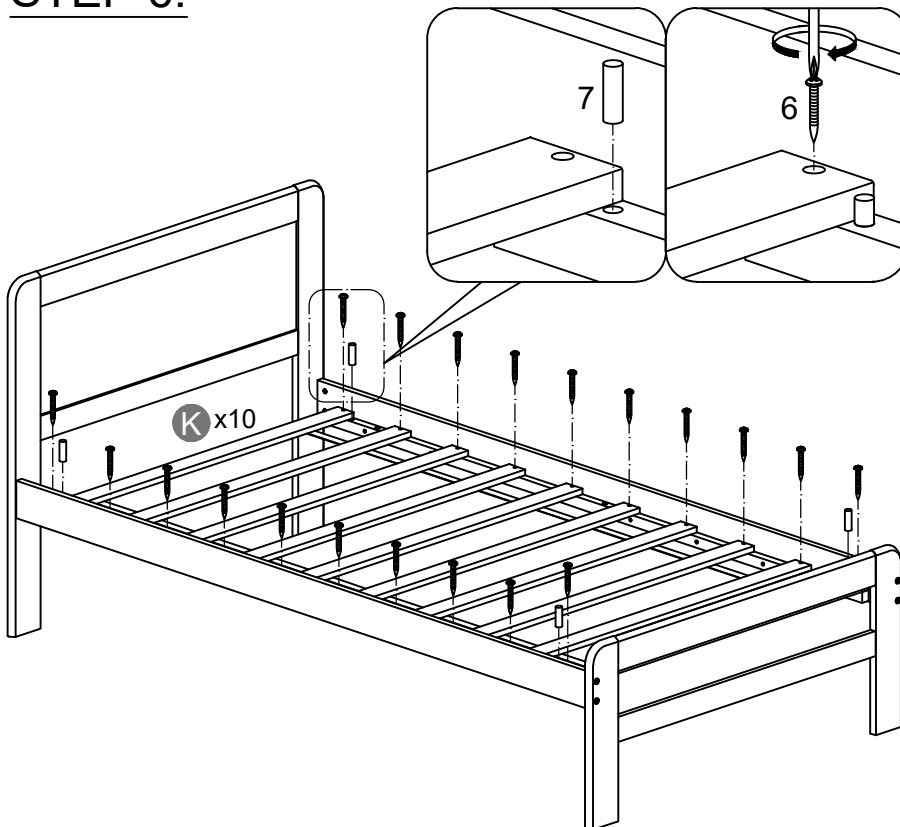

6



20 pcs

7

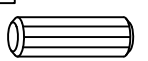

4 pcs

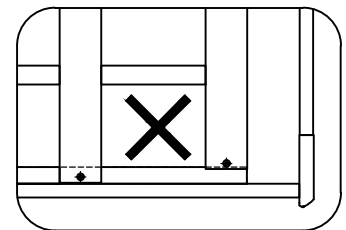
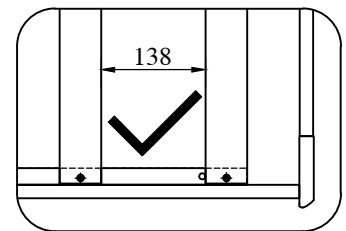

Note: Do not lock the screws of the bed slats to the outermost edge of the bed slats, you need to leave a certain space at the edges, otherwise it will cause the board to break. Do not lock the bed slats on the edge of the wood, please hold firmly before screwing, hold it in place with one hand, then lock the screw.

STEP 7:

6



8 pcs

13

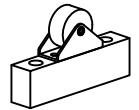

4 pcs

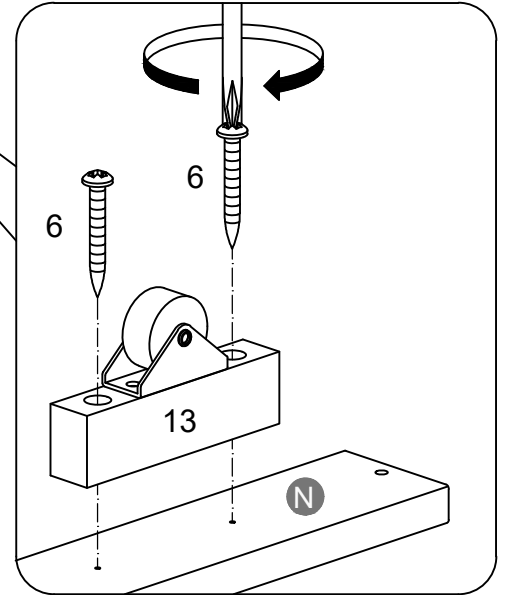
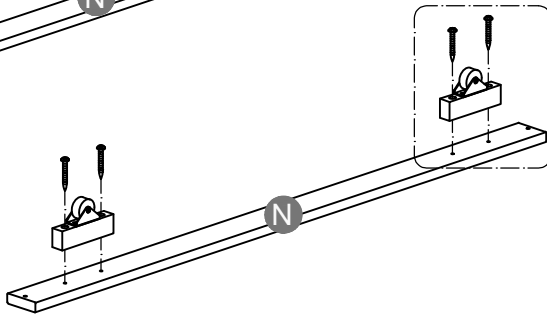
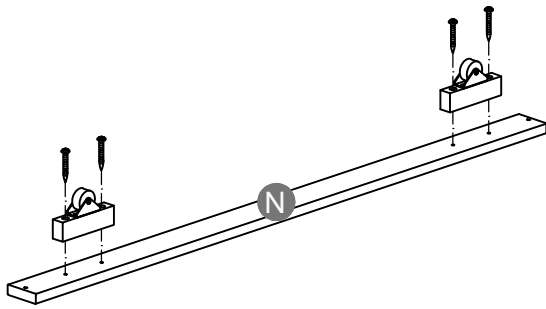

STEP 8:

6



14 pcs

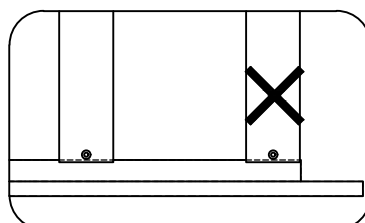
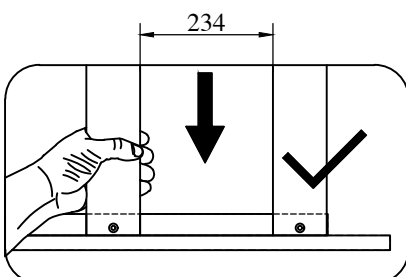
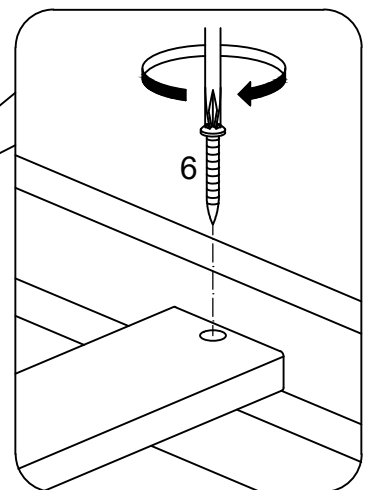
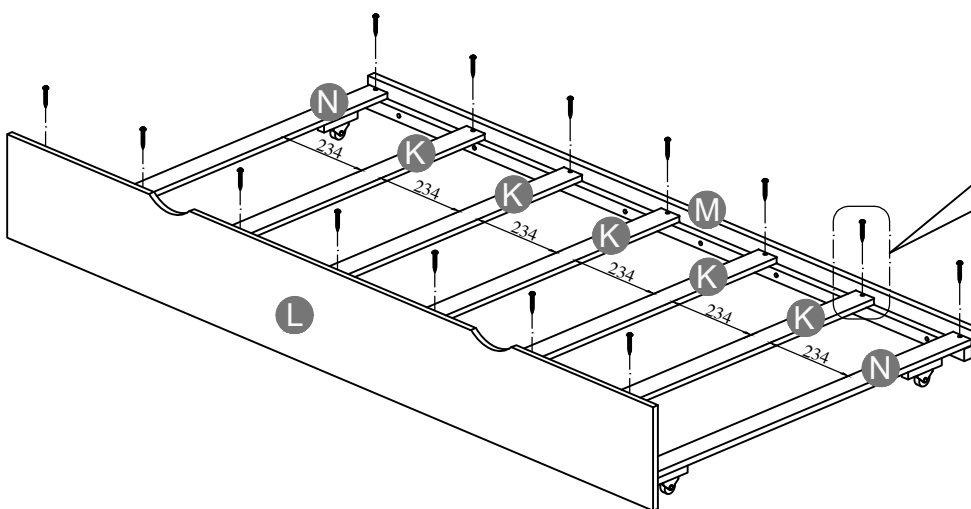

Note: Do not lock the screws of the bed slats to the outermost edge of the bed slats, you need to leave a certain space at the edges, otherwise it will cause the board to break. Do not lock the bed slats on the edge of the wood, please hold firmly before screwing, hold it in place with one hand, then lock the screw

STEP 9:

10

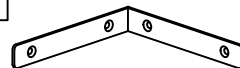

2 pcs

12



8 pcs

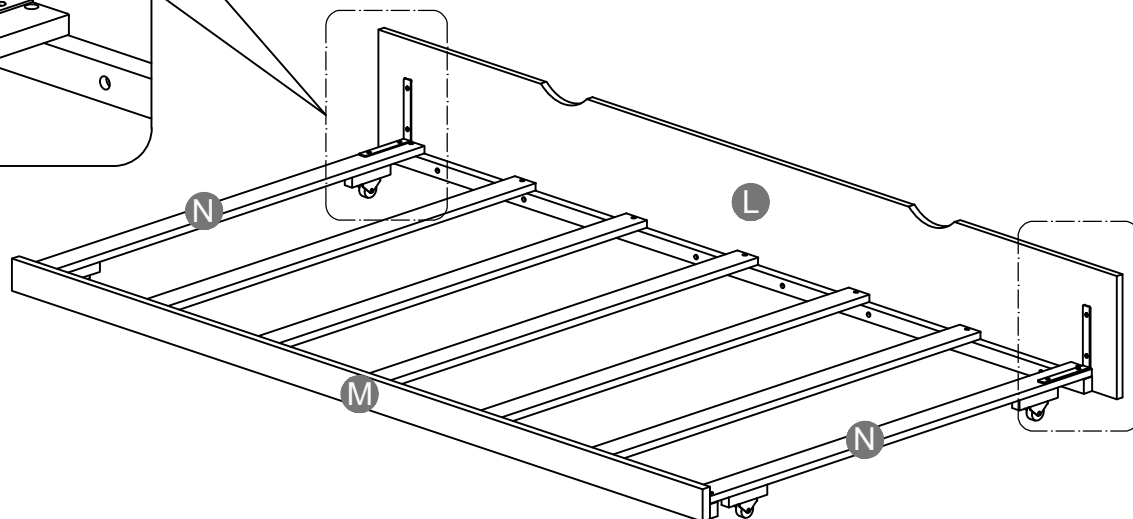
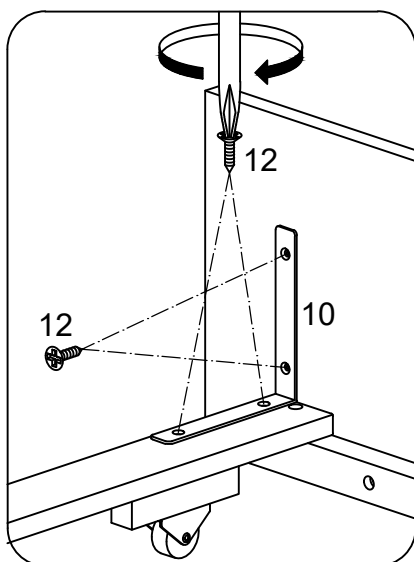

STEP 10:

11

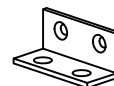

2 pcs



12

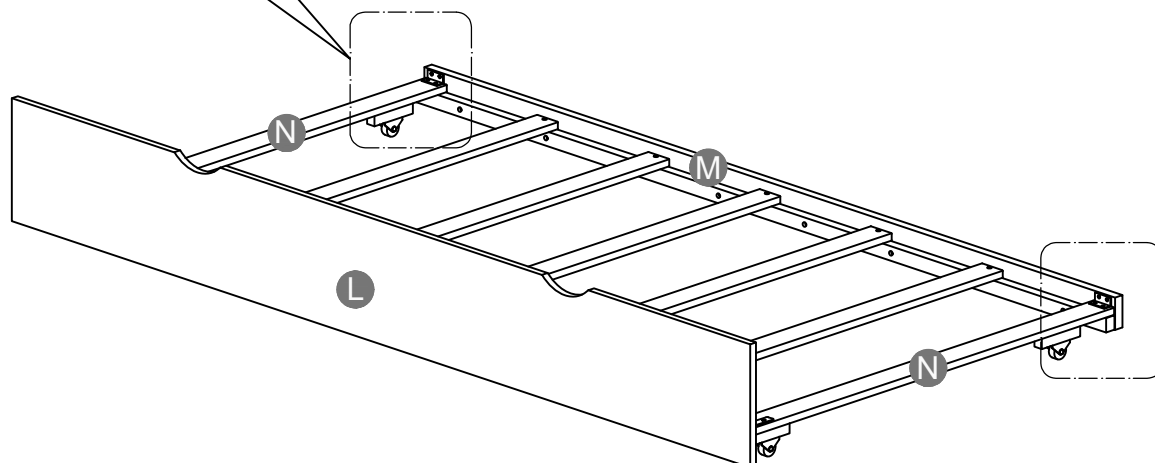
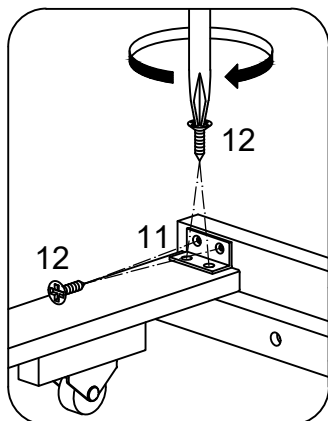

8 pcs

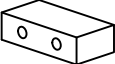

STEP 11:

| | |
|-----------|---|
| 4 |  (Ø12)1/4"*55mm |
| 2pcs | |
| 7 |  |
| 2pcs | |
| 14 |  |
| 2pcs | |

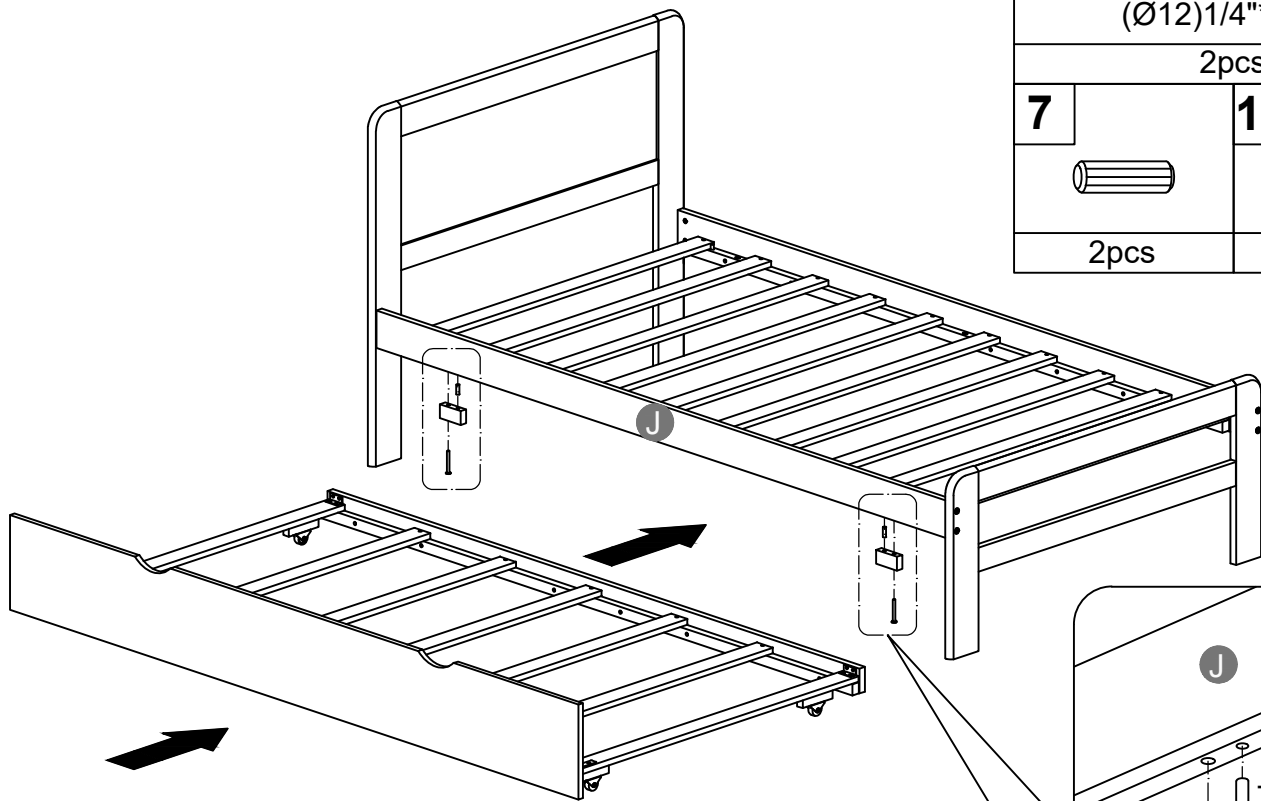

Push Trundle under the bottom of Bed.

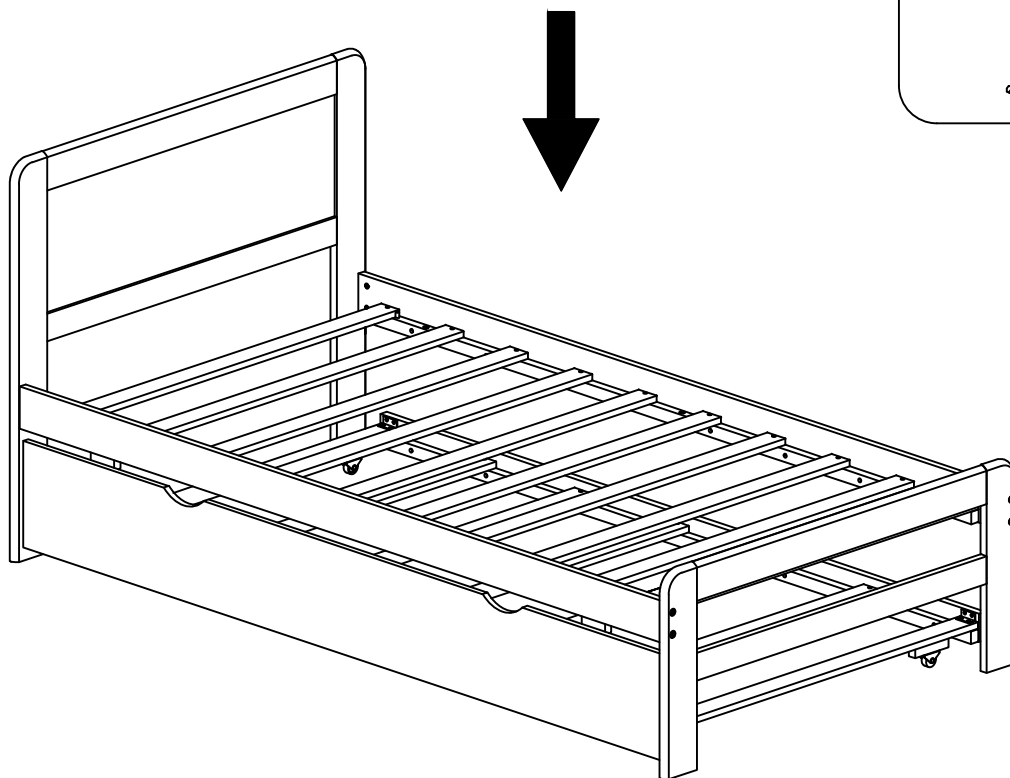
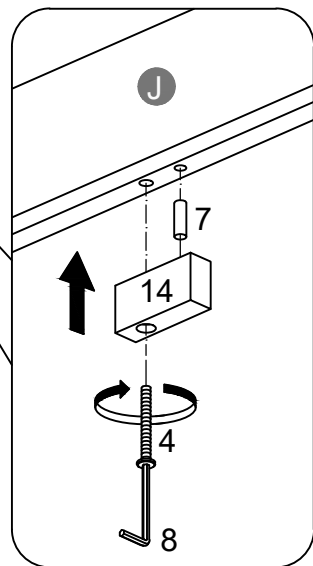

Make sure to tighten all the screws of the bed.