

A x 1

B x 1

C x 2

D x 1

E x 1

F x 8

Bolt M6x25

G x 4

Bolt M6x20

H x 4

Glass position shaping piece 15x15x2

I x 4

M6x25/D20

K x 1

Allen Key 4

* Please check all the parts listed . Find the hardware attached to the package's bottom by A RED STRING. Contact us if you have damaged or missing any components.
 * Please watch and follow our assembly video on our product page.
 * You can use ELECTRIC SCREWDRIVER for easier assembly.

II. PRODUCT ASSEMBLY

"DO NOT tighten the screws until all of parts set into correct position"

STEP 1:

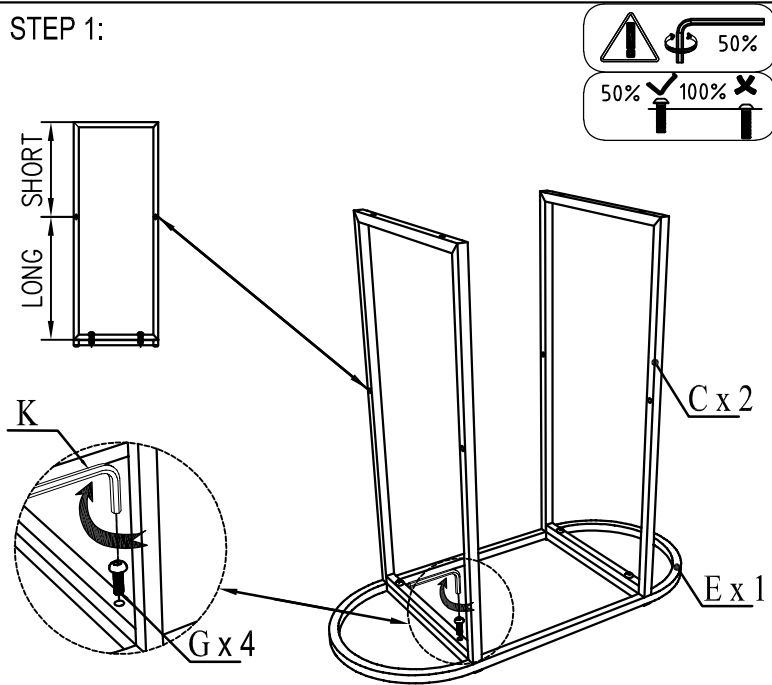

STEP 2:

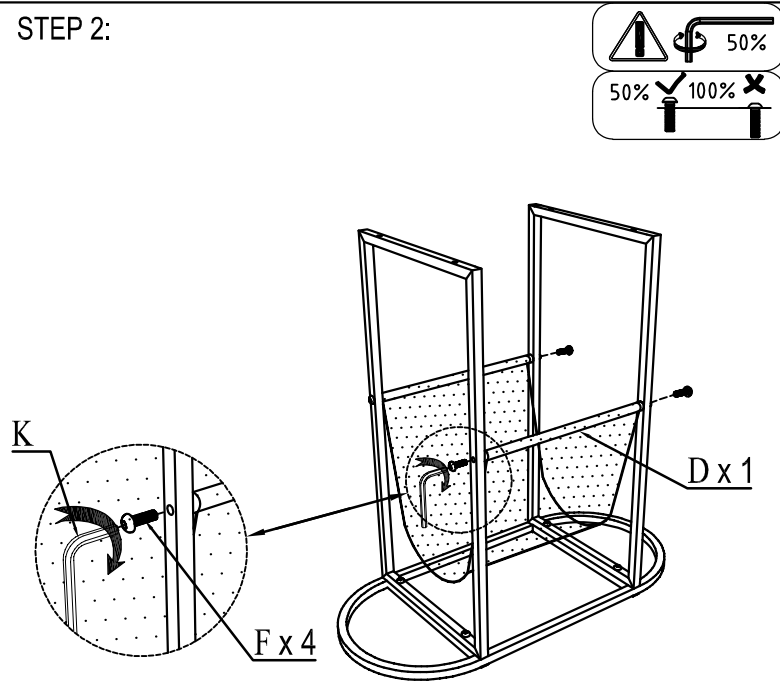

STEP 3:

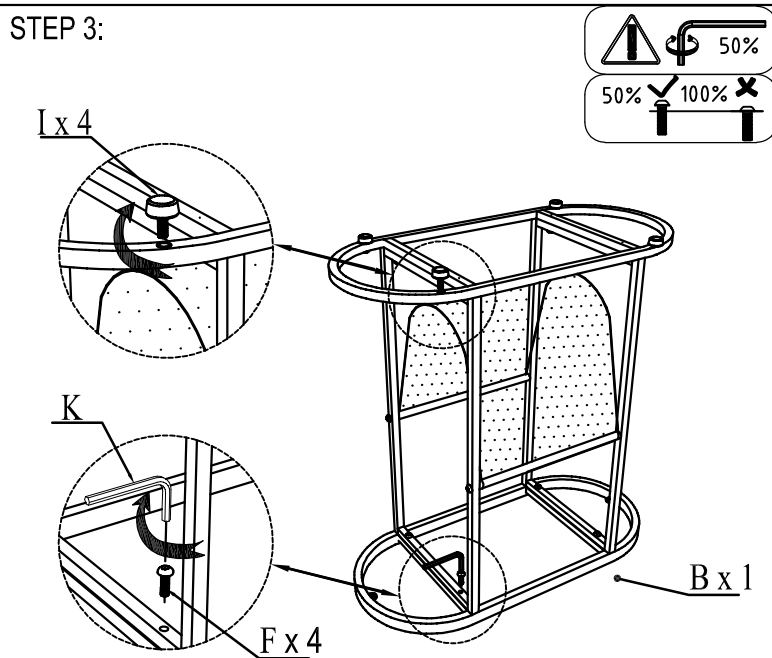

STEP 4:

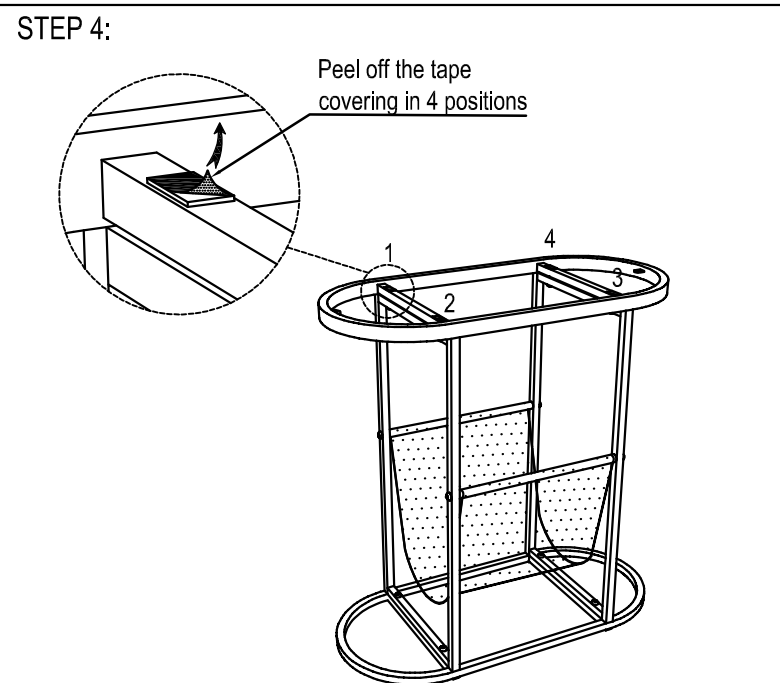

STEP 5:

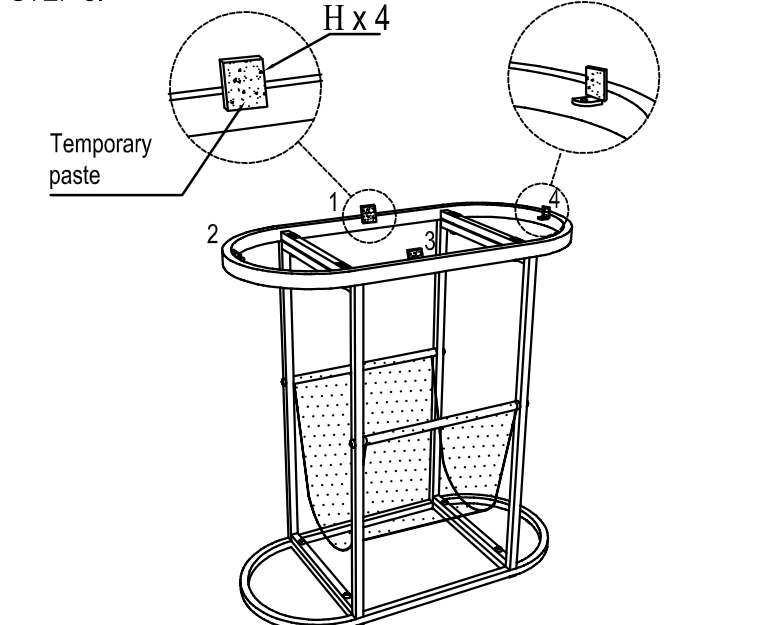

STEP 6:

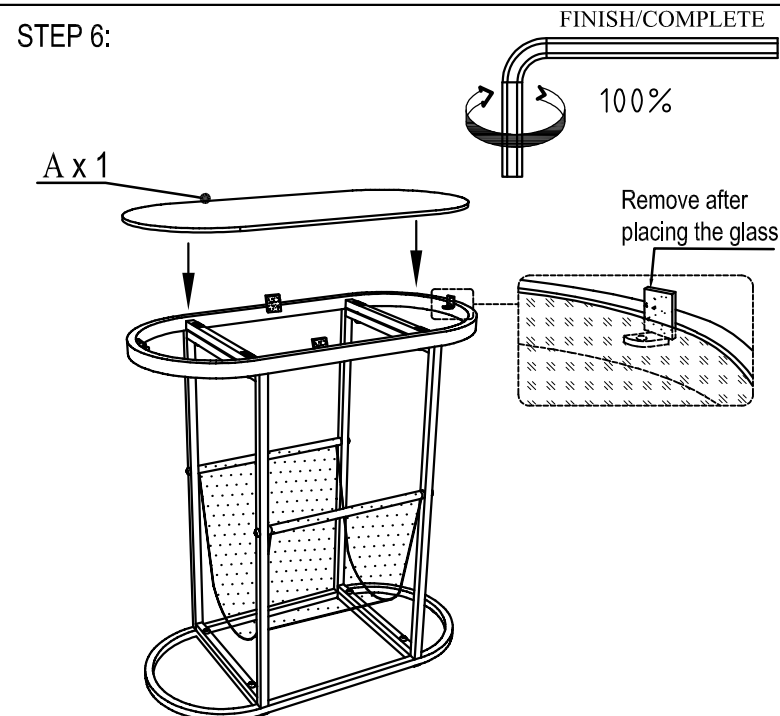

Note: This step aims to make sure the glass place in middle of steel frame. You can skip this step if you can directly make it place in middle of steel frame.