

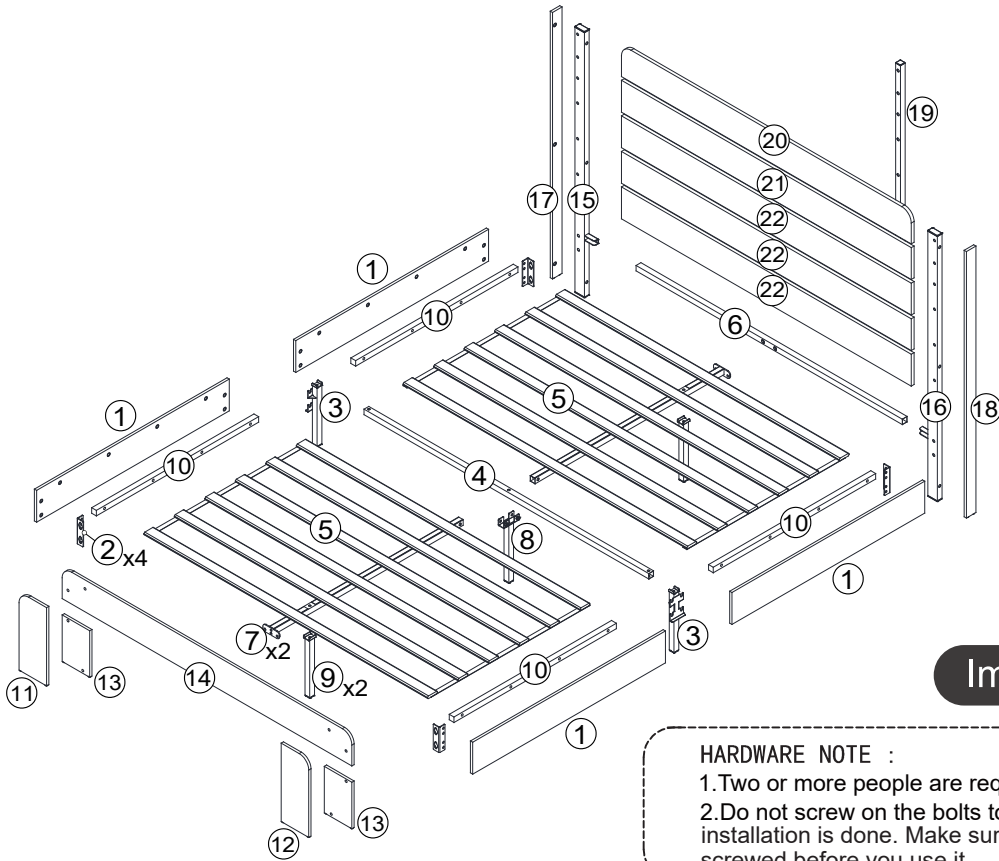







Assembly Instruction



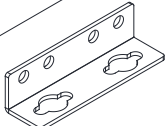

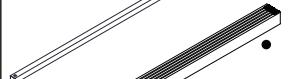



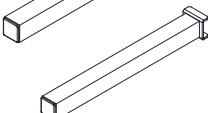

Important Note

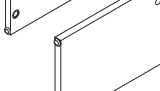
HARDWARE NOTE :
 1. Two or more people are required for assembly
 2. Do not screw on the bolts too tight unless the installation is done. Make sure all bolts are tightly screwed before you use it.

Components

-  ① x4pcs
-  ② x4pcs
-  ③ x2pcs
-  ④ x1pc
-  ⑤ x2pcs
-  ⑥ x1pc
-  ⑦ x2pcs
-  ⑧ x1pc
-  ⑨ x2pcs

-  ⑩ x4pcs
-  ⑪ x1pc
-  ⑫ x1pc
-  ⑬ x2pcs
-  ⑭ x1pc
-  ⑮ x1pc
-  ⑯ x1pc
-  ⑰ x1pc
-  ⑱ x1pc
-  ⑲ x1pc

4
x2

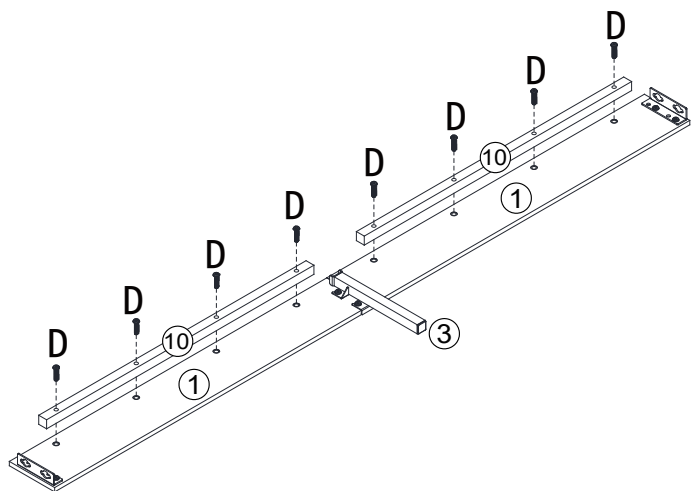

| | | |
|---|---|-------|
| D |  | 16pcs |
| | M8x33 | |

5

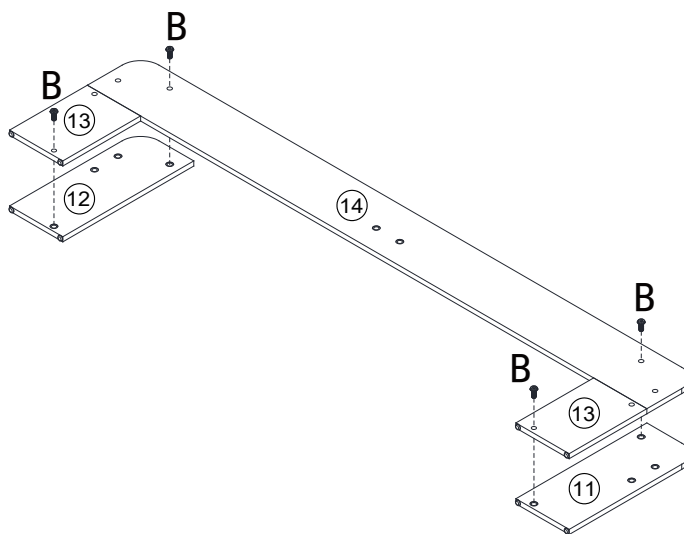

| | | |
|---|--|------|
| B |  | 4pcs |
| | M8x20 | |

Tighten screws C

6

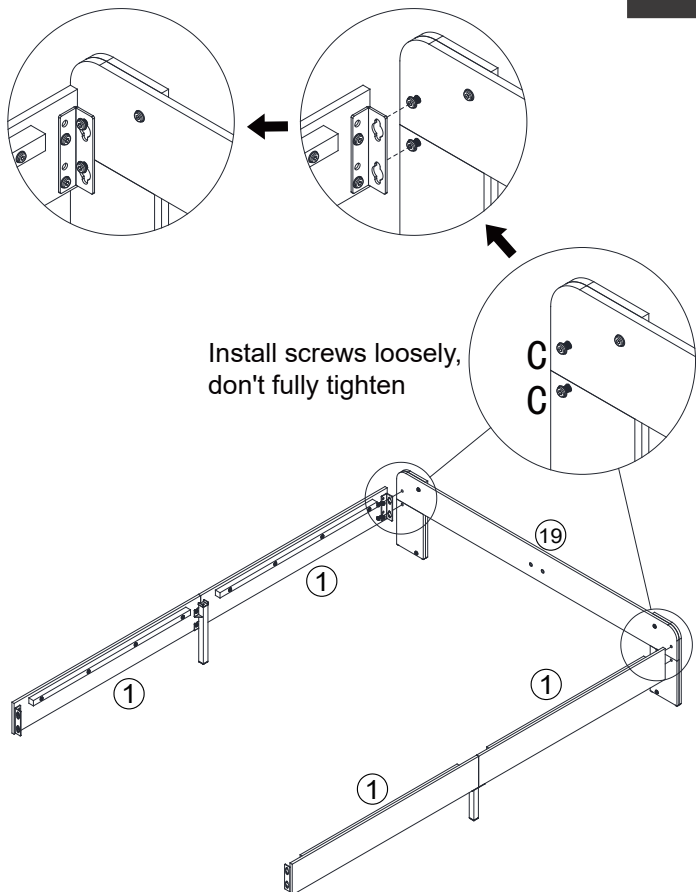

| | | | |
|---|---|------|------------|
| C |  | 4pcs | white zinc |
| | M8x25 | | |

7

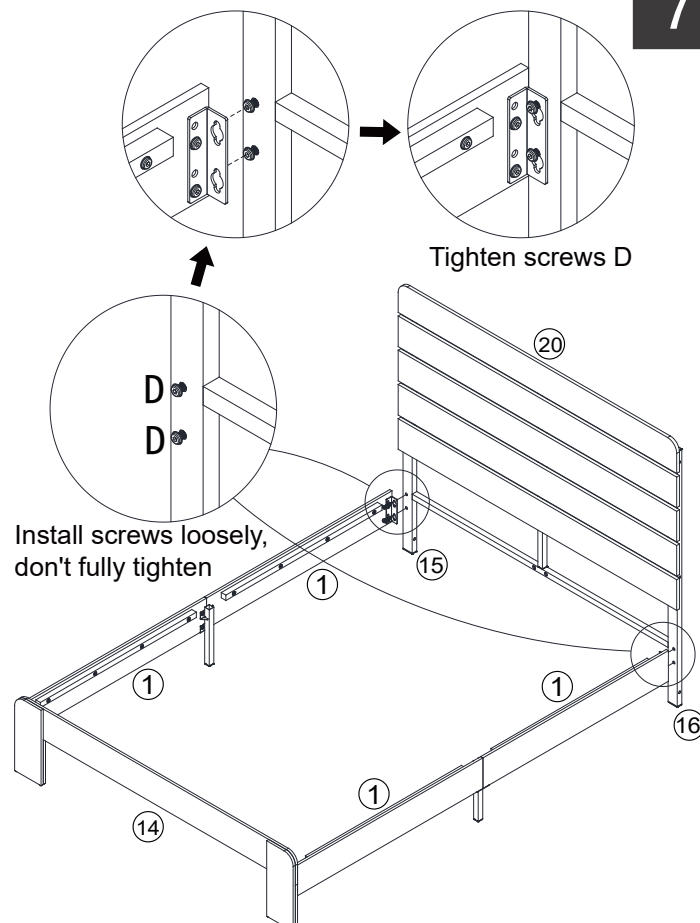

| | | |
|---|--|------|
| D |  | 4pcs |
| | M8x33 | |

8

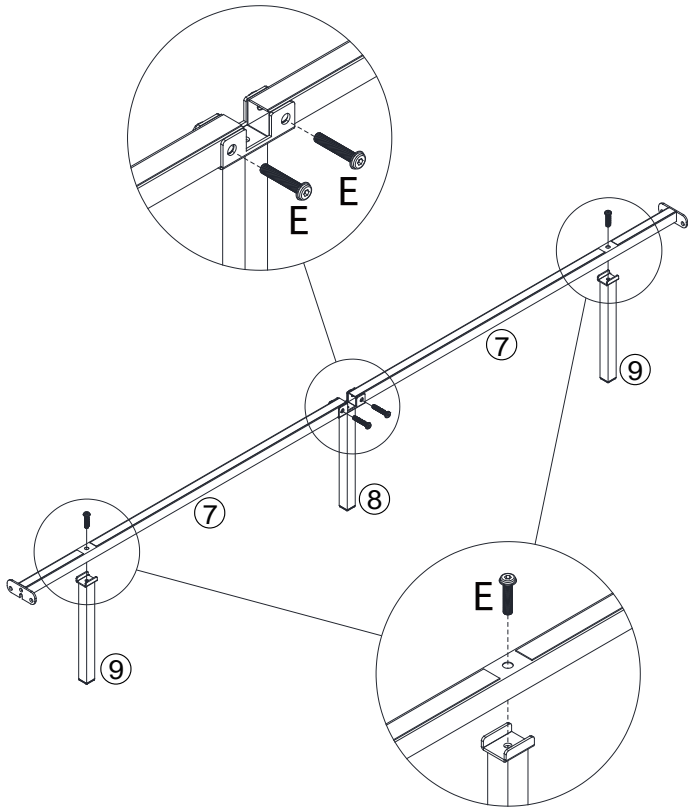



| | | | |
|---|---|-------|------|
| E |  | M8x45 | 4pcs |
|---|---|-------|------|

Assemble second

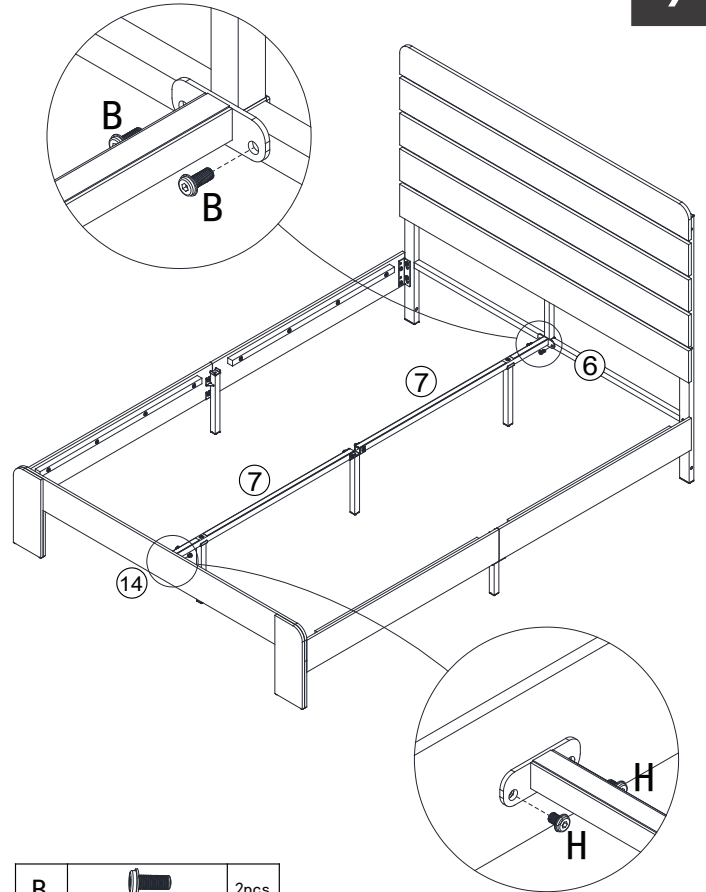
9





| | | | |
|---|---|-------|------|
| B |  | M8x20 | 2pcs |
| H |  | M8x14 | 2pcs |

white zinc

to Assemble first

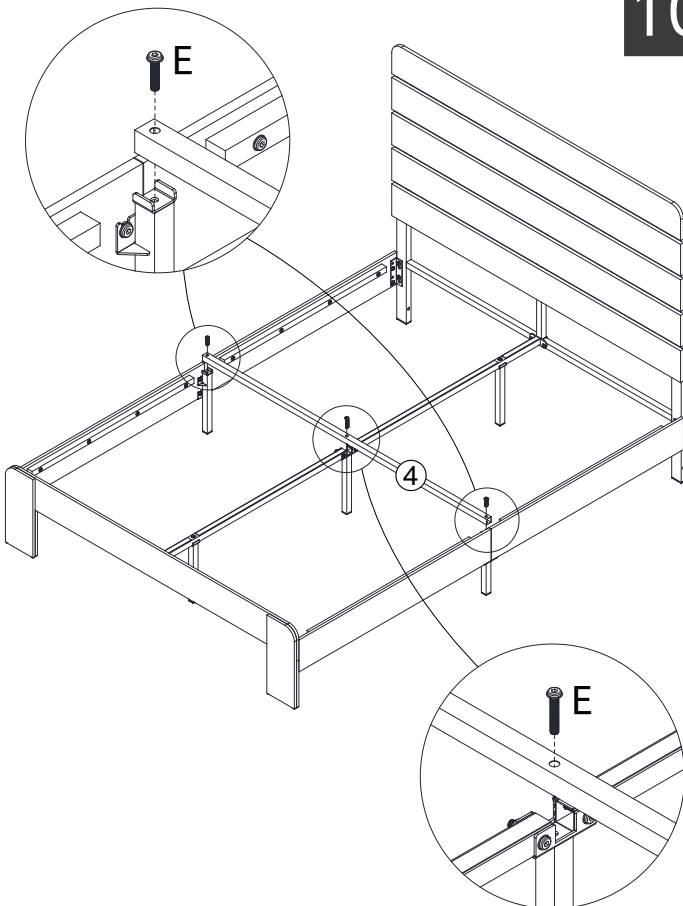
10



| | | | |
|---|---|-------|-----|
| E |  | M8x45 | 3pc |
|---|---|-------|-----|

11

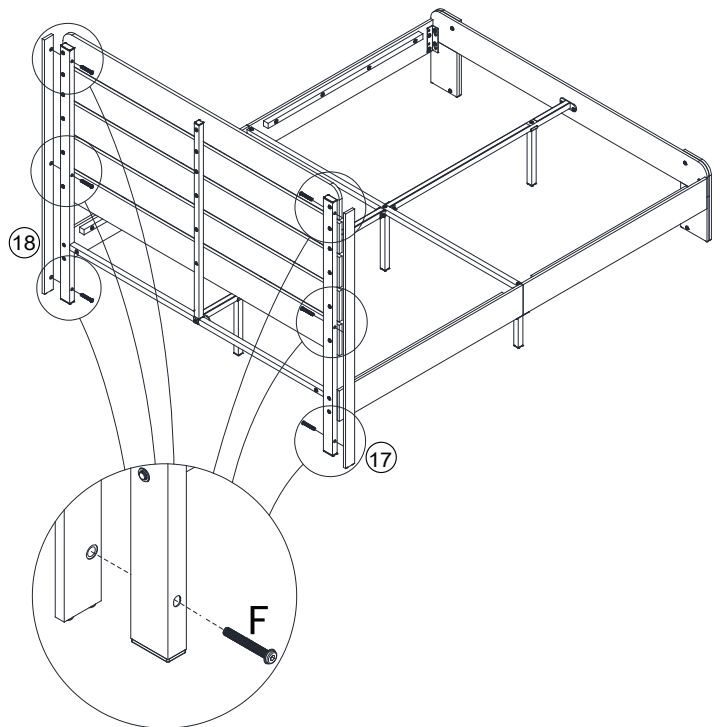

| | | | |
|---|--|-------|------|
| F |  | M8x60 | 6pcs |
|---|--|-------|------|

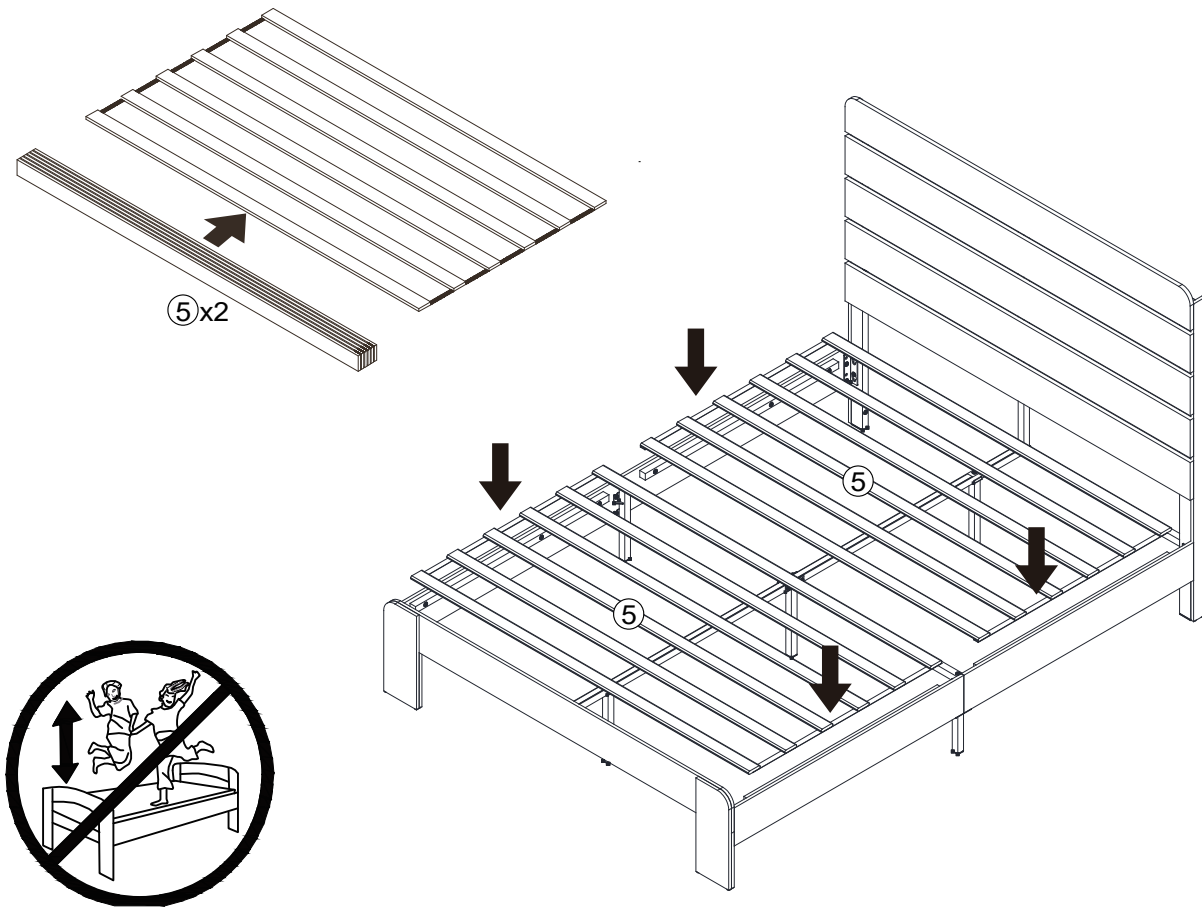

Finish

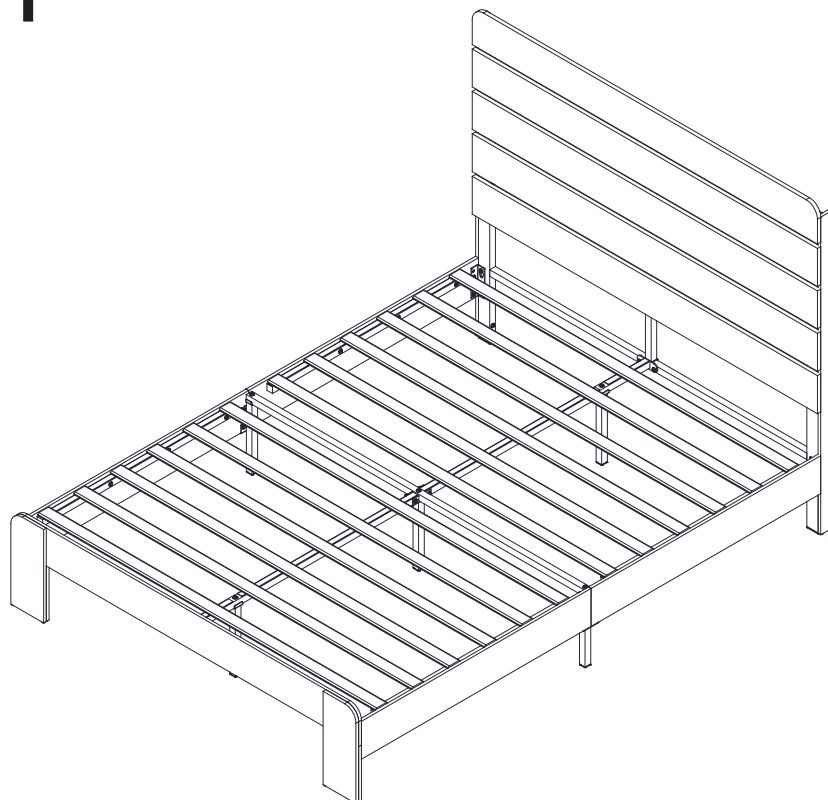

Note: Now you can tighten all the bolts.