

ASSEMBLY INSTRUCTIONS

N704P165645 MAKEUP VANITI SET

IMPORTANT NOTE :





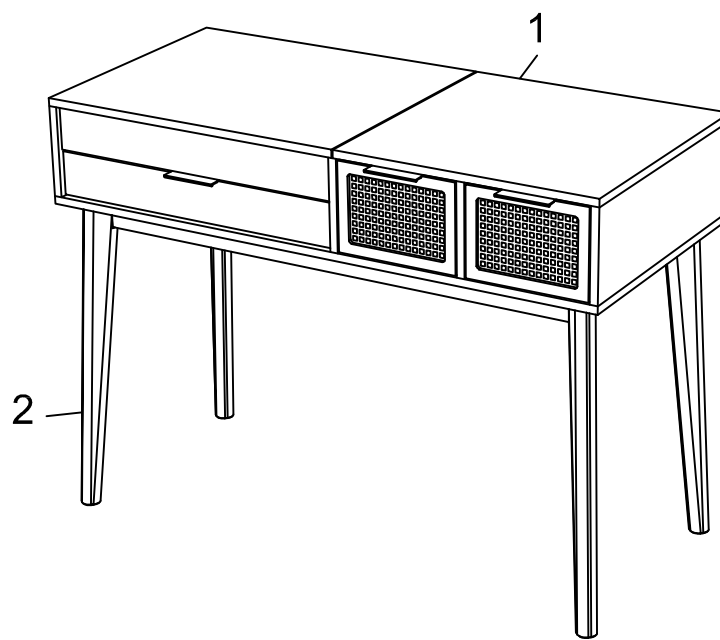

** PLACE ALL PARTS ON A CLEAN AND SMOOTH SURFACE SUCH AS A RUG OR CARPET TO AVOID THE PARTS FROM BEING SCRATCHED.

** BEFORE YOU BEGIN, KINDLY FOLLOW THE ASSEMBLY INSTRUCTIONS STEP BY STEP.

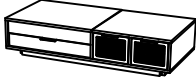
**DO NOT TIGHTEN ALL SCREWS AND BOLTS UNTIL THE TABLE IS FULLY SET-UP.



CARTONS ONLY ONE/ CARTONS SEULEMENT UN

PART LISTS				HARDWARE LISTS			
NO.	DESCRIPTION	SKETCH	Q'TY	NO.	DESCRIPTION	SKETCH	Q'TY
1	TOP FRAME		1 PC	A	BOLT Ø 5/16" x 60mmL		8 PCS
2	LEGS		4 PCS	B	SPRING WASHER Ø 5/16" x 12 mm		8 PCS
				C	FLAT WASHER Ø 5/16" x 18 mm		8 PCS
				D	ALLEN WRENCH 4 mm		1 PC

ASSEMBLY INSTRUCTIONS

STEP 1 :

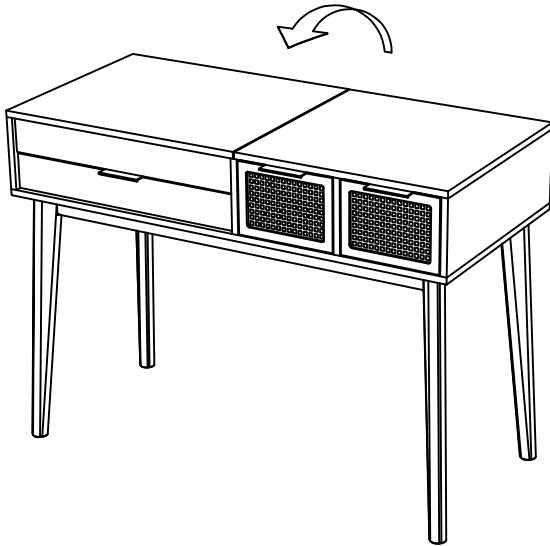
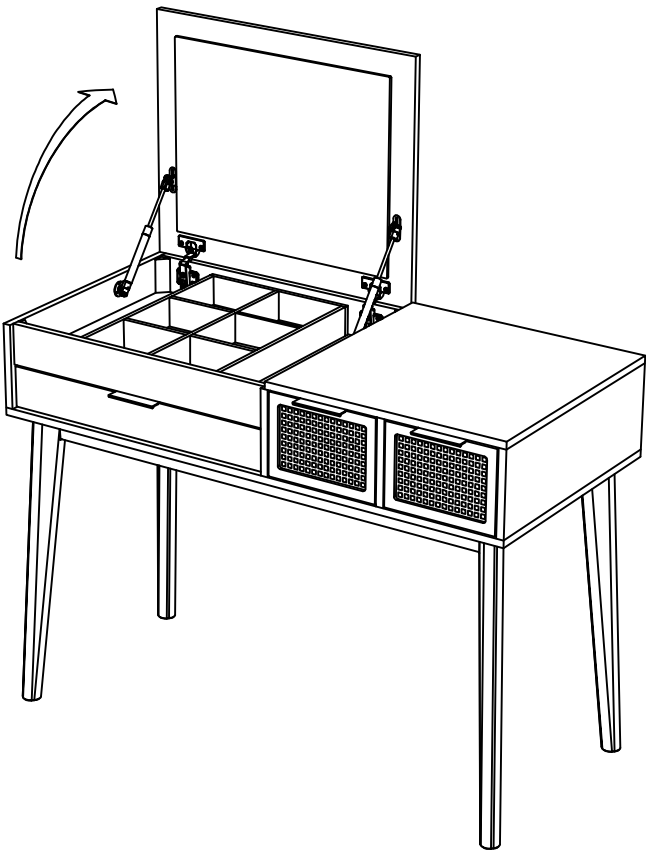
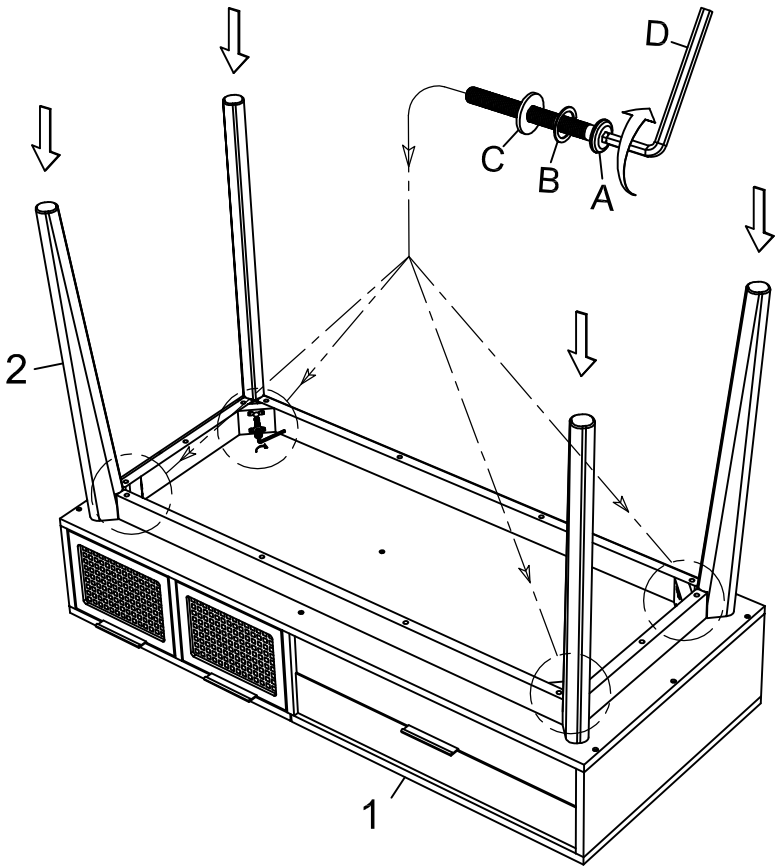

ASSEMBLY INSTRUCTIONS

N704P165645 MAKEUP VANITI SET

IMPORTANT NOTE :





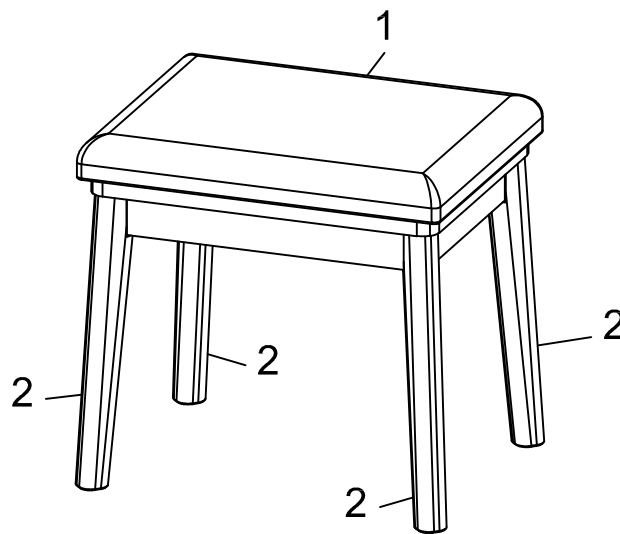

** PLACE ALL PARTS ON A CLEAN AND SMOOTH SURFACE SUCH AS A RUG OR CARPET TO AVOID THE PARTS FROM BEING SCRATCHED.

** BEFORE YOU BEGIN, KINDLY FOLLOW THE ASSEMBLY INSTRUCTIONS STEP BY STEP.

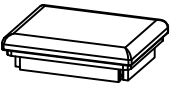
**DO NOT TIGHTEN ALL SCREWS AND BOLTS UNTIL THE STOOL IS FULLY SET-UP.



CARTONS ONLY ONE/ CARTONS SEULEMENT UN

PART LISTS				HARDWARE LISTS			
NO.	DESCRIPTION	SKETCH	Q'TY	NO.	DESCRIPTION	SKETCH	Q'TY
1	TOP FRAME		1 PC	A	BOLT Ø 1/4" x 60mmL		8 PCS
2	LEGS		4 PCS	B	SPRING WASHER Ø 1/4" x 12 mm		8 PCS
				C	FLAT WASHER Ø 1/4" x 18 mm		8 PCS
				D	ALLEN WRENCH 4 mm		1 PC

ASSEMBLY INSTRUCTIONS

STEP 1 :

