

ASSEMBLY INSTRUCTION

DINING SET

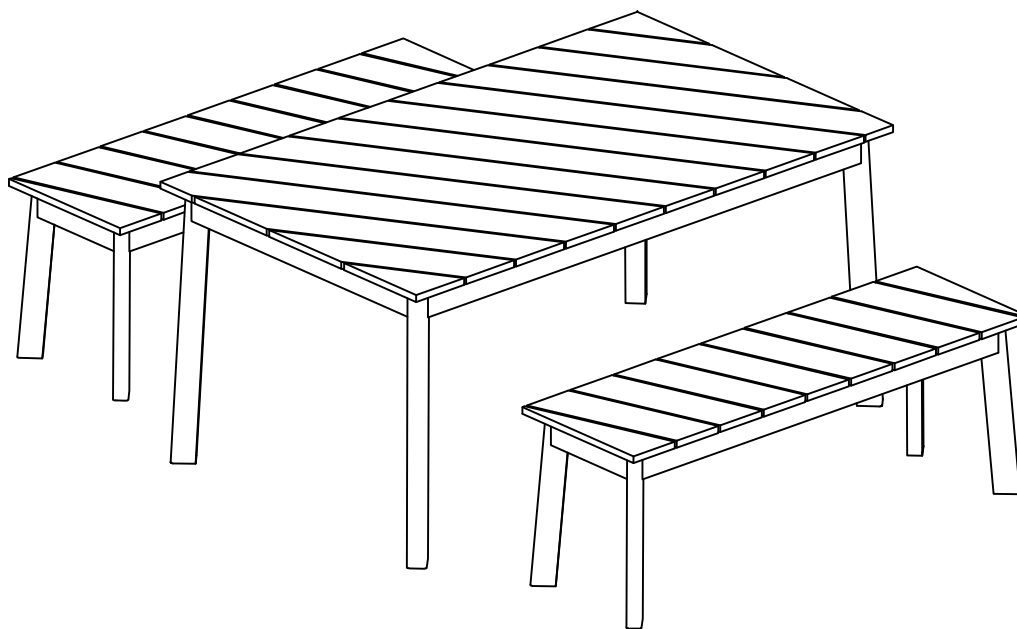

WF319179; WF319180

Notice :

1. 50% Tighten before fixing all screws, Allen wrench is recommended instead of an electric drill.
2. Place the item on a flat ground to adjust and make sure it remains stable.
3. Tighten up all screws with tools gradually.
4. If the screws are not aligned with holes during assembly, please loosen all the other screws to 50% and continue the assembly process.
5. If the item is not stable, please loosen all the screws, adjust it on a flat ground and tighten up all screws again.
6. Note : If one or some screws are fully tightened during assembly, chances are the others will not be aligned with holes. In addition, all the holes are designed to be relatively larger to provide more space for the adjustment of the screws.

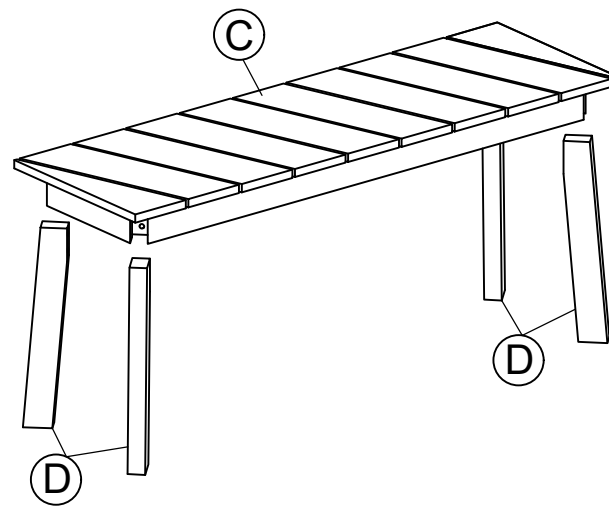
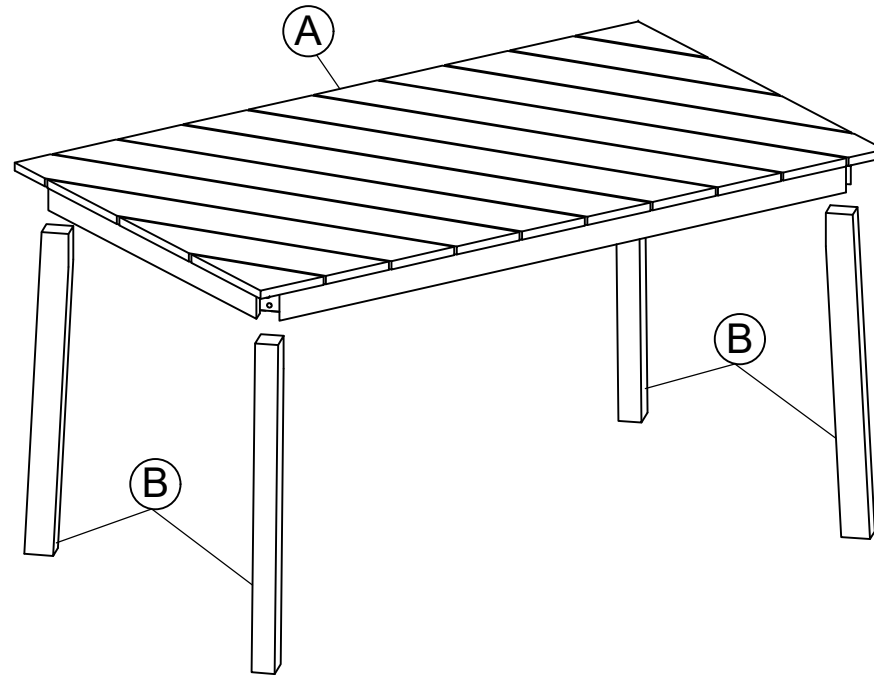

x2

Part List :

A

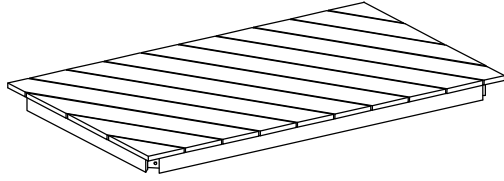

Table Top (1 pc)

B



Leg Table (4 pcs)

C

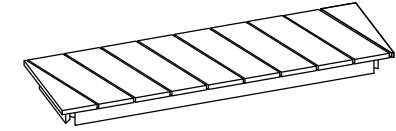

Seat Bench Frame (2 pcs)

D



Leg Bench (8 pcs)

Hardware List :

1



Extra (3 pcs)
Allen Bolt M8*70mm (24 pcs)

2



Extra (3 pcs)
Washer M8 (24 pcs)

3



Allen Key (2 pcs)

CARTON CONTENT

WF319179

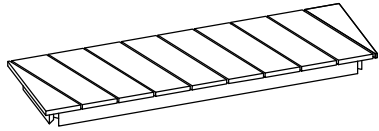

Ⓒx 2



Ⓓx 8

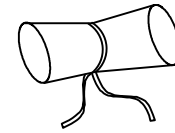

Hardware

WF319180

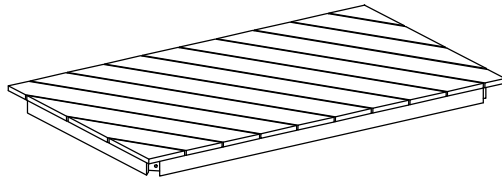

Ⓐx1



Ⓑx4

STEP 1

- A x1
- B x4
- ① x8
- ② x8

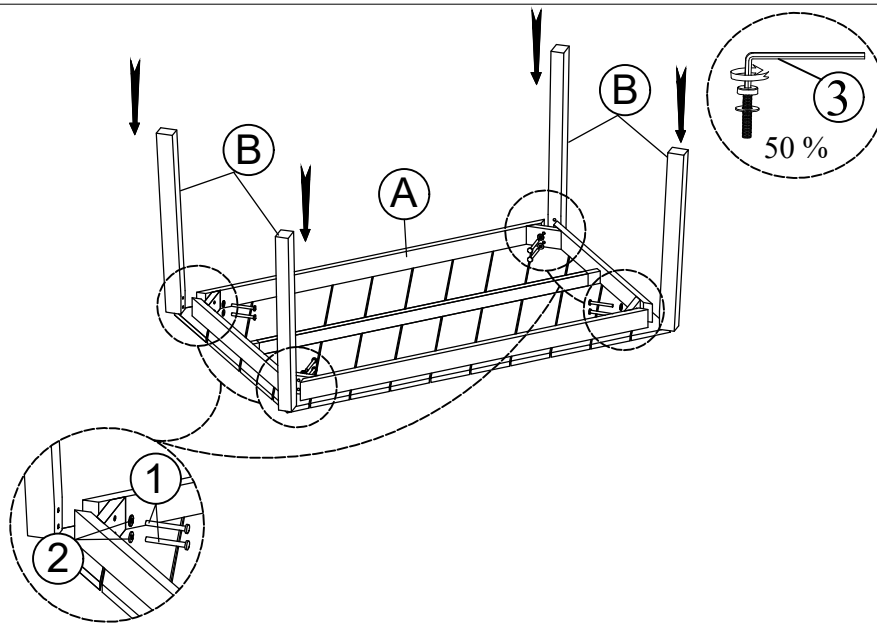

Connect Table Top (A) & Leg Table (B) with Allen Bolt (1), Washer (2), Allen Key (3).

STEP 2

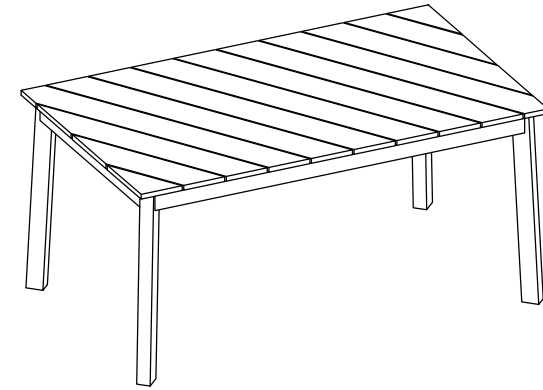

Put the Table upright, firmly tighten Bolts with Allen Key (3) to Finish Table.

STEP 3

- C x1
- D x4
- ① x8
- ② x8

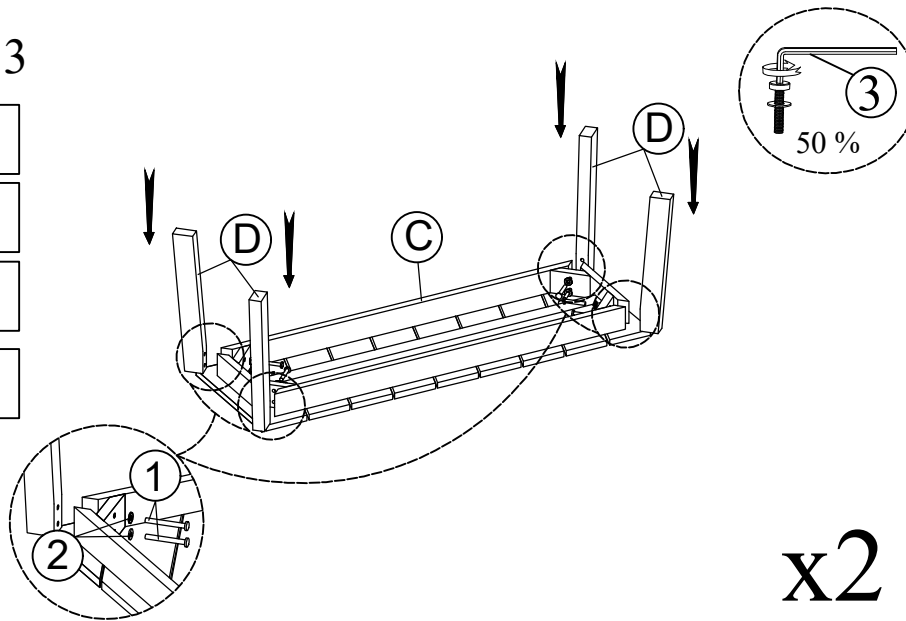

Connect Seat Bench Frame (C) & Leg Bench (D) with Allen Bolt (1), Washer (2), Allen Key (3).

STEP 4

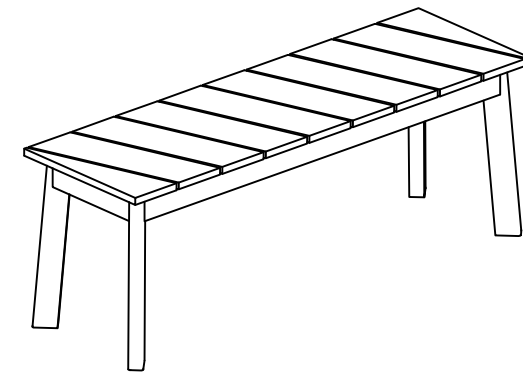

Put the Bench upright, firmly tighten Bolts with Allen Key (3) to Finish Bench.

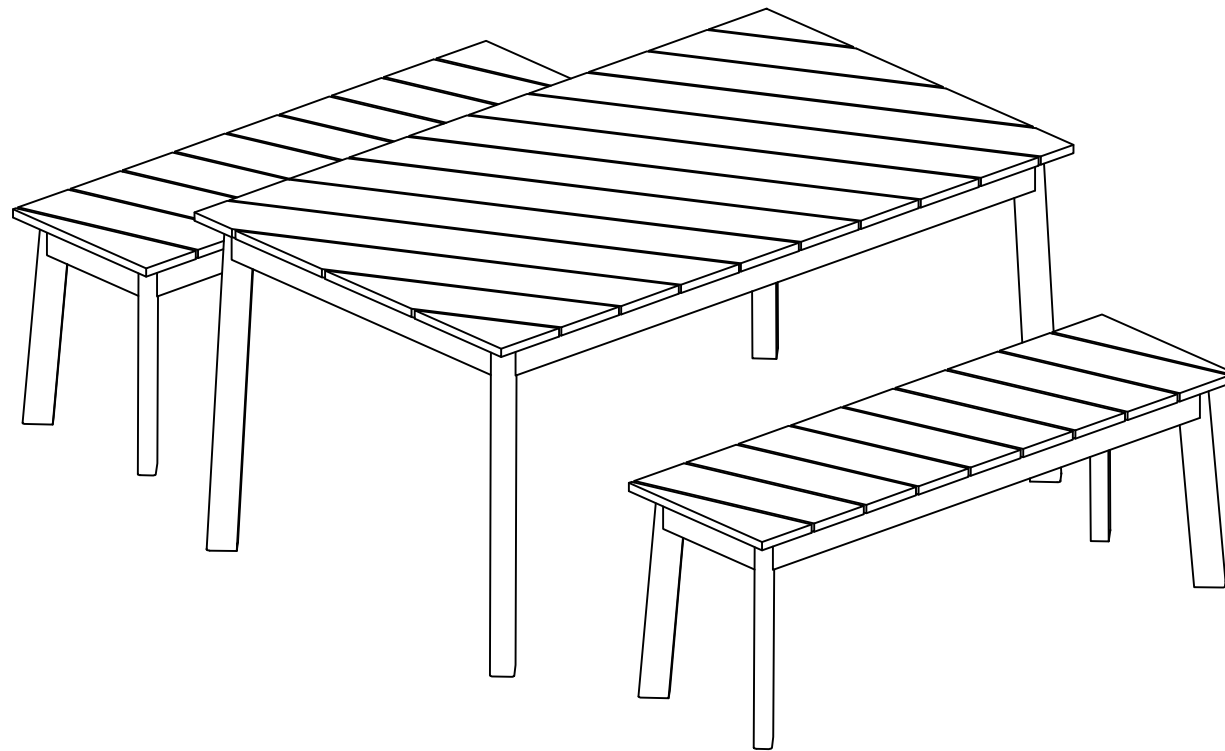

Finish .