

SMP0003BK
SMP0003WT
SMP0003GY

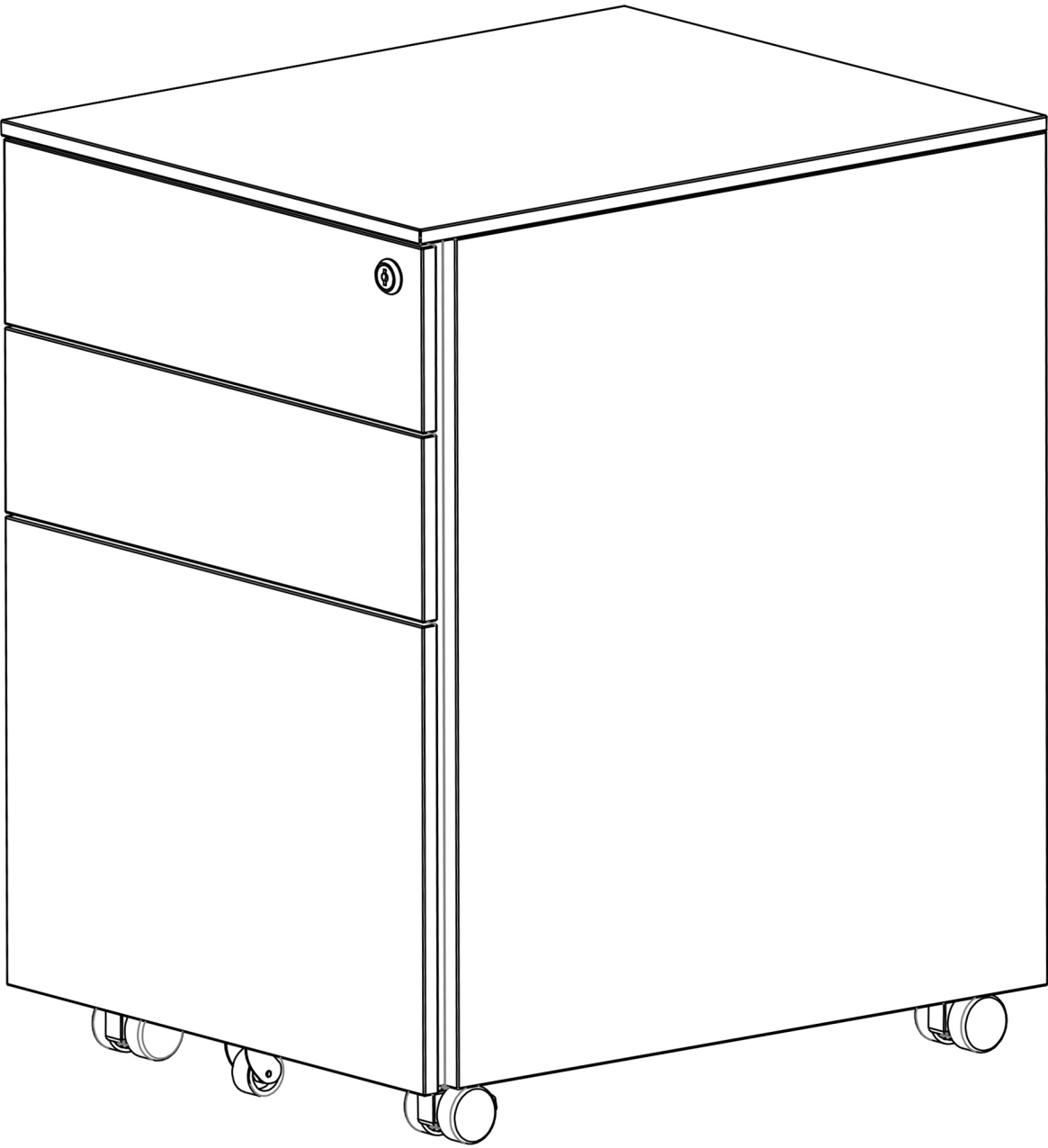



3-DRAWER MOBILE FILE CABINET

⚠ Attention: If you notice any fingerprints on the surface please know that they were left there during manual lifting. Simply clean the surface using a cloth and rubbing alcohol.

1. Gather and organize all required parts before assembling.
2. Assemble cabinet on a flat, clean, soft surface.

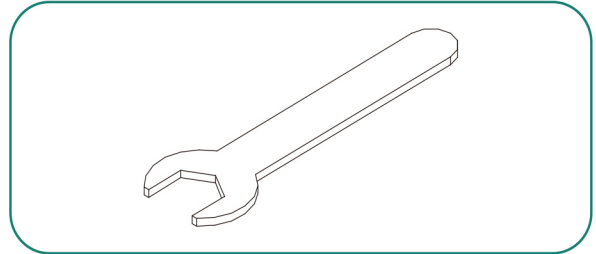
Tools Required For Assembly

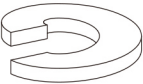
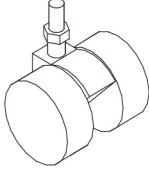
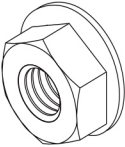
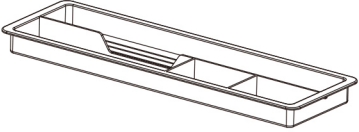
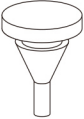
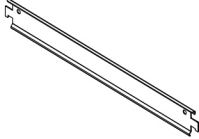
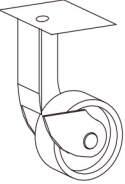
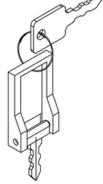
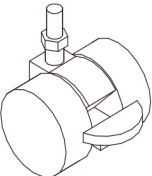

Item no.	Reference Image	Qty.	Item no.	Reference Image	Qty.
a		X5	f		X2
b		X5	g		X1
c		X2	h		X1
d		X1	i		X1
e		X2	j		X1

1 
j 1pc

Unlock to open the bottom drawer

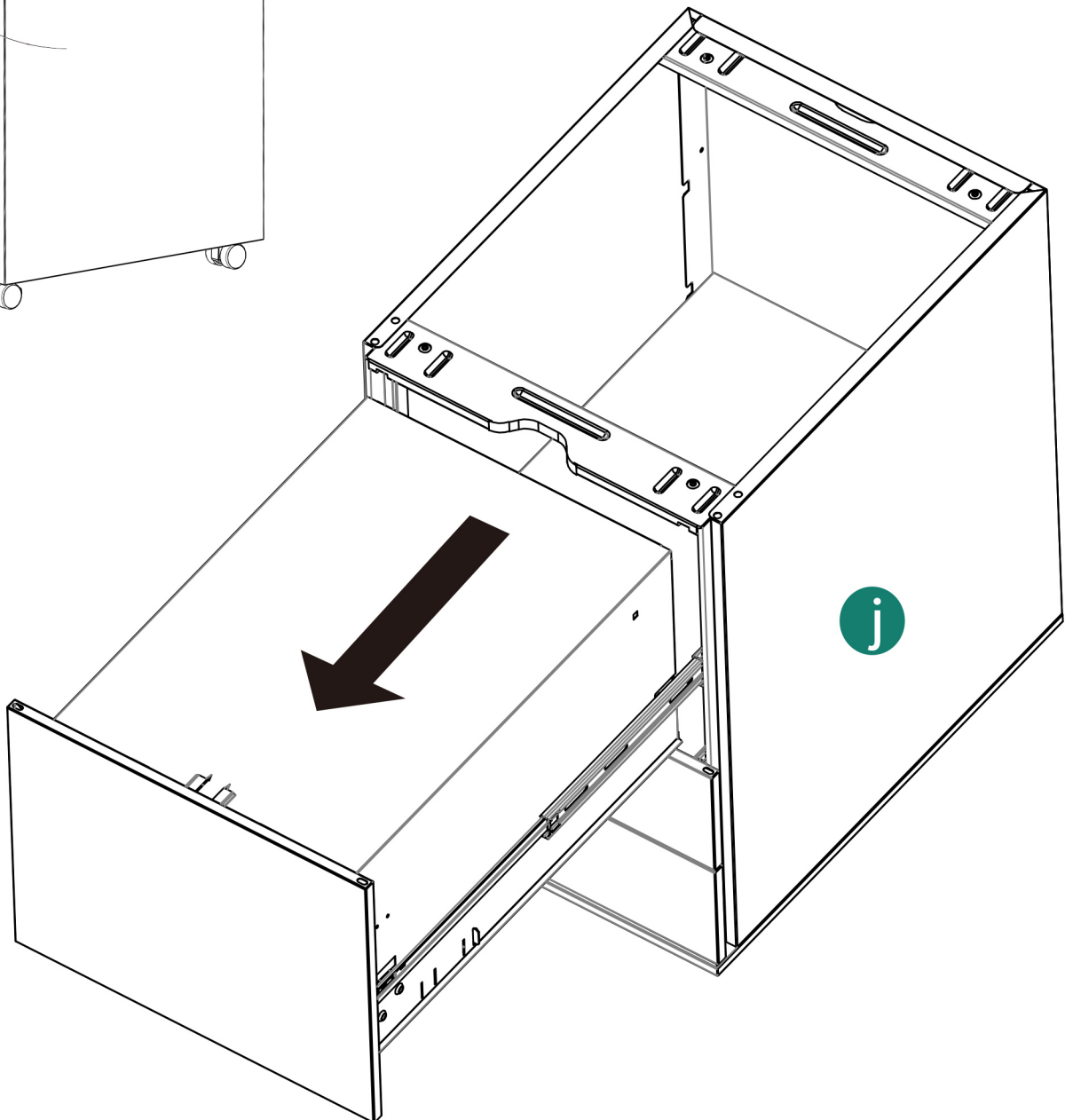
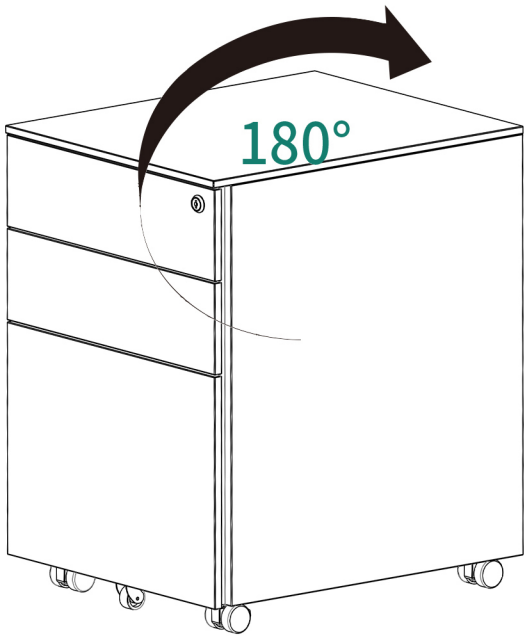

2

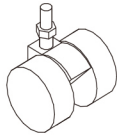

f 2pcs

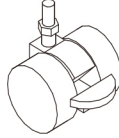

e 2pcs



a 4pcs



b 4pcs

An extra caster with a brake is provided.

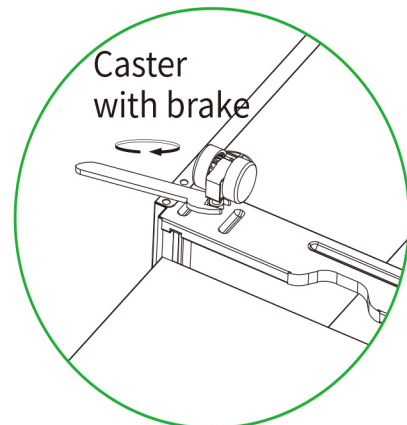
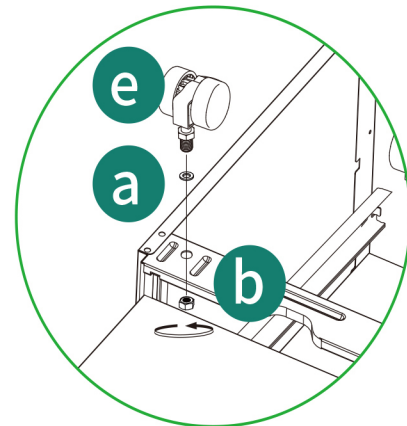
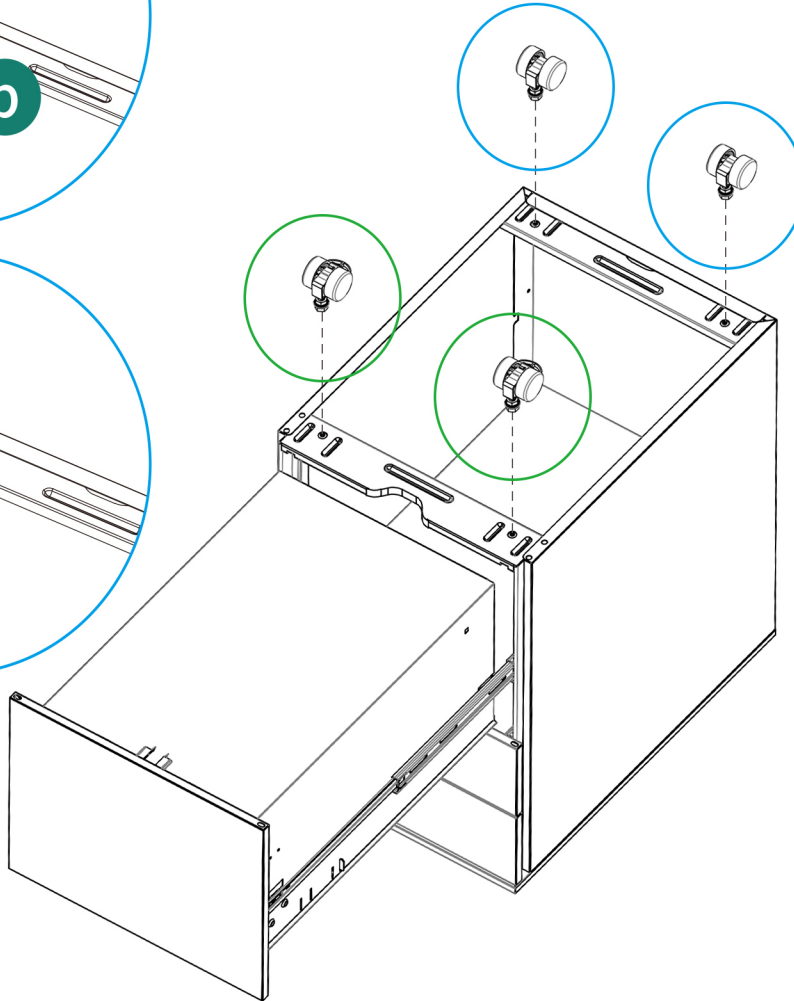
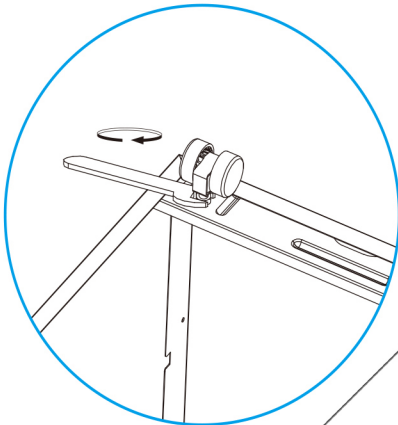
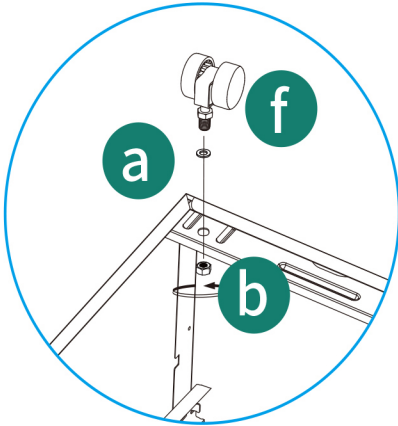

3

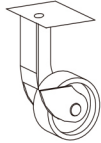

①1pc

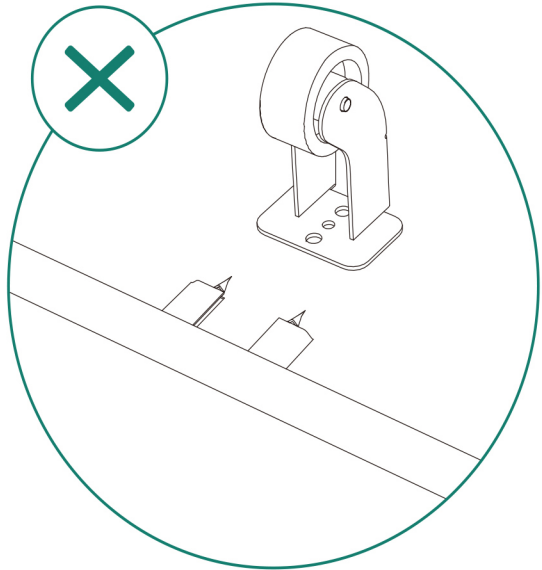
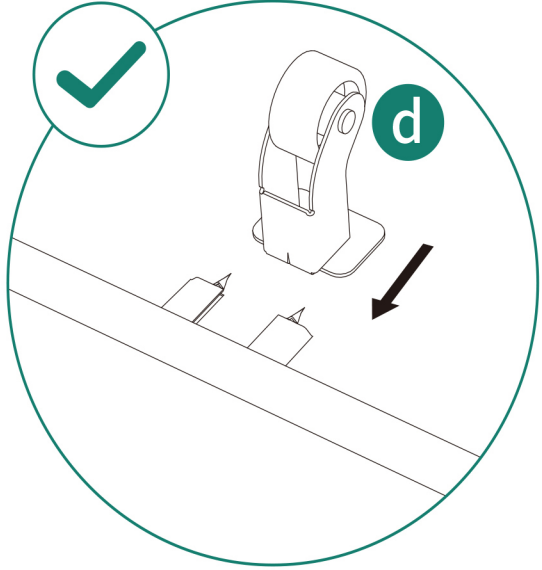
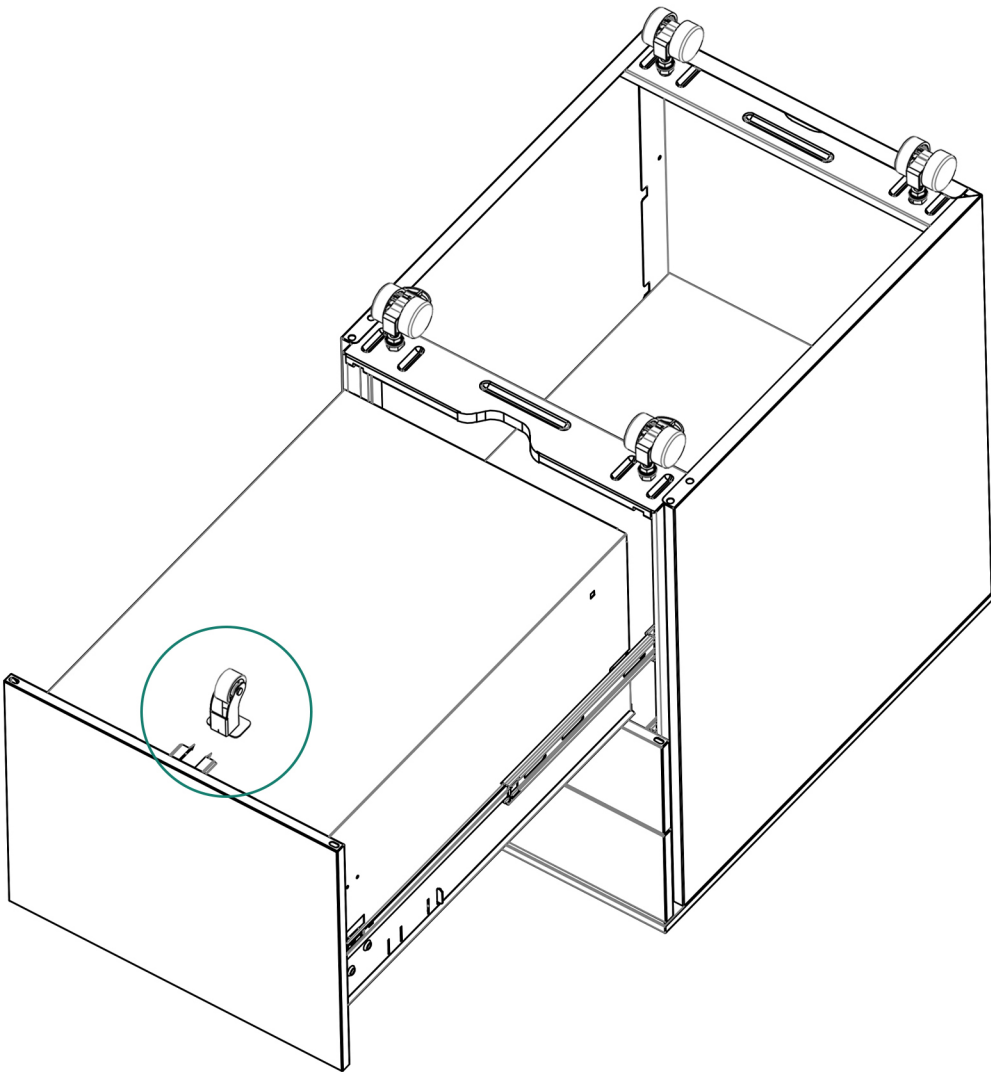

4

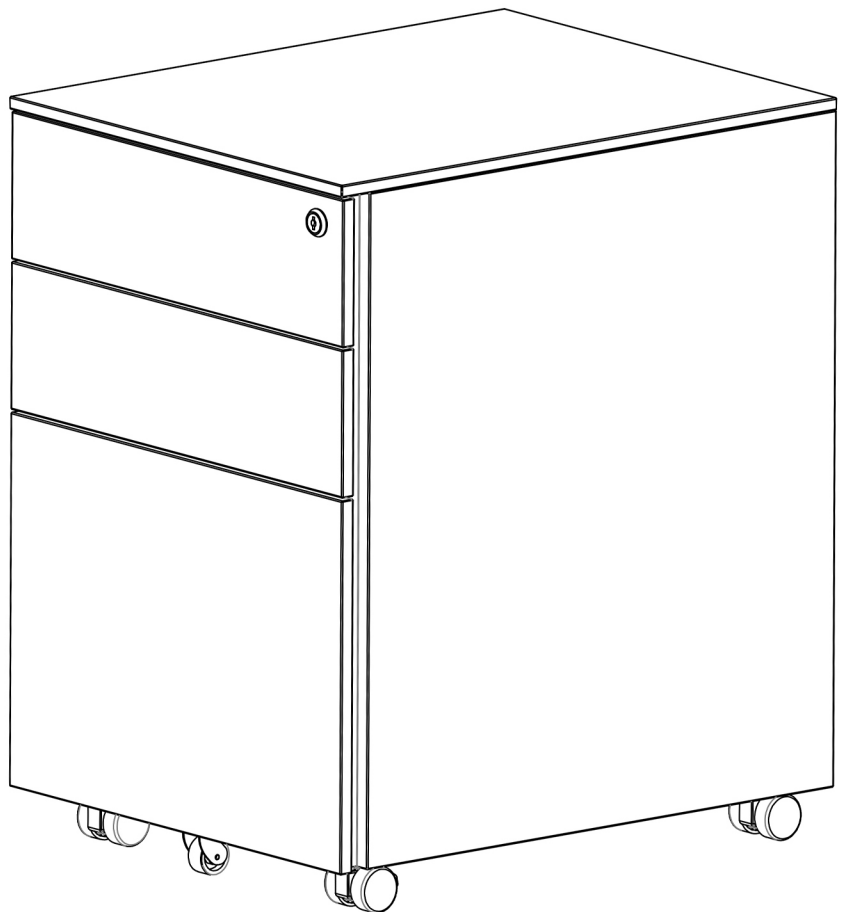
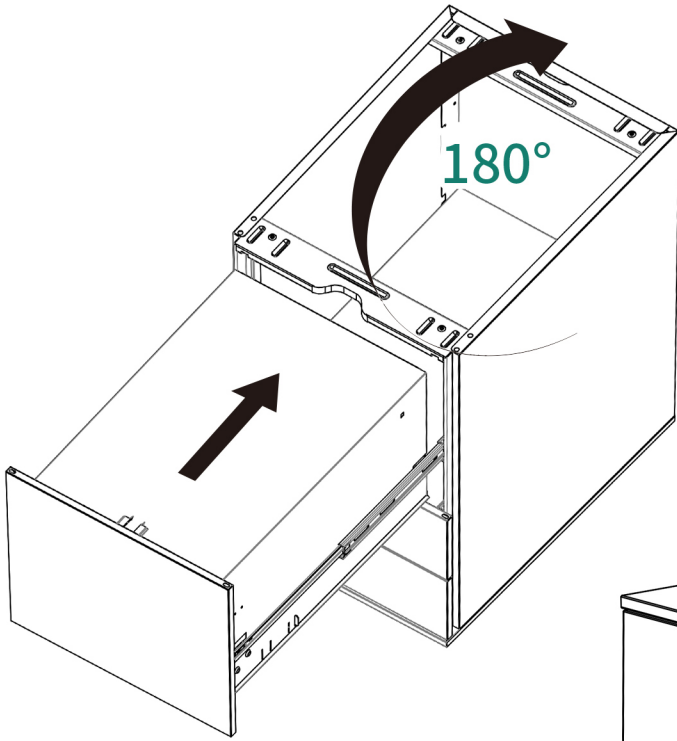

5

5



©1pc

Open the bottom drawer, install the rubber buckle, and fix the anti-tip wheel (wheel C) in place.

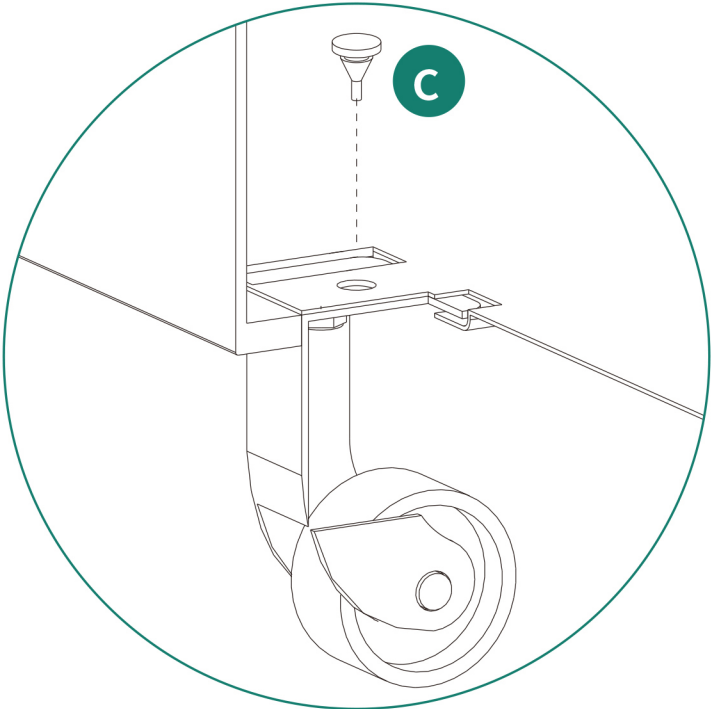
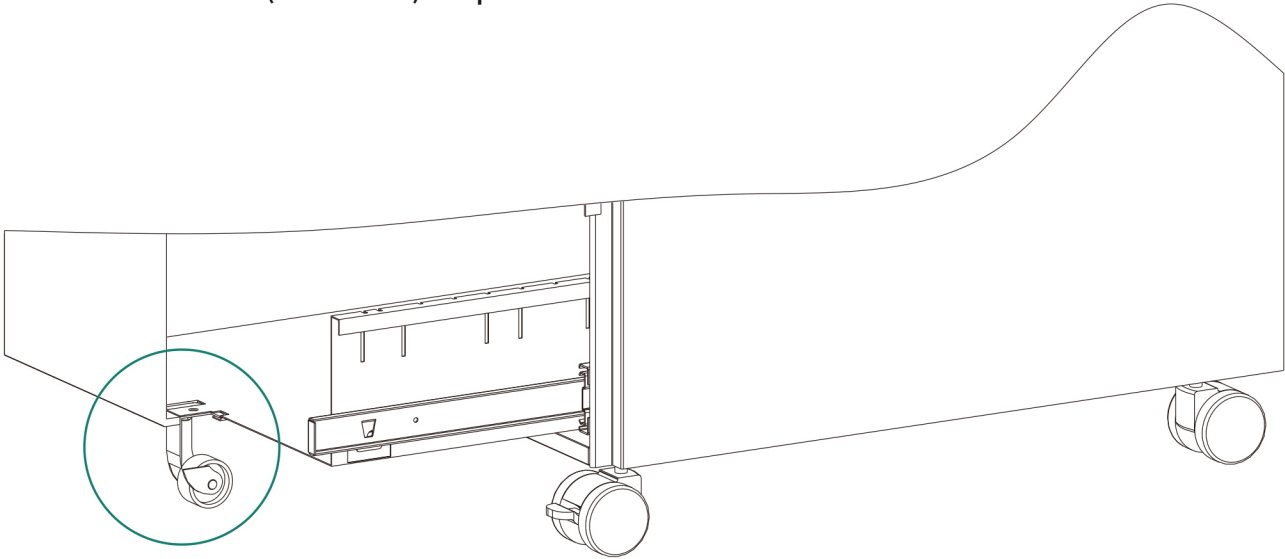

6

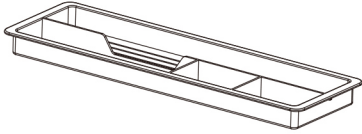

g 1pc

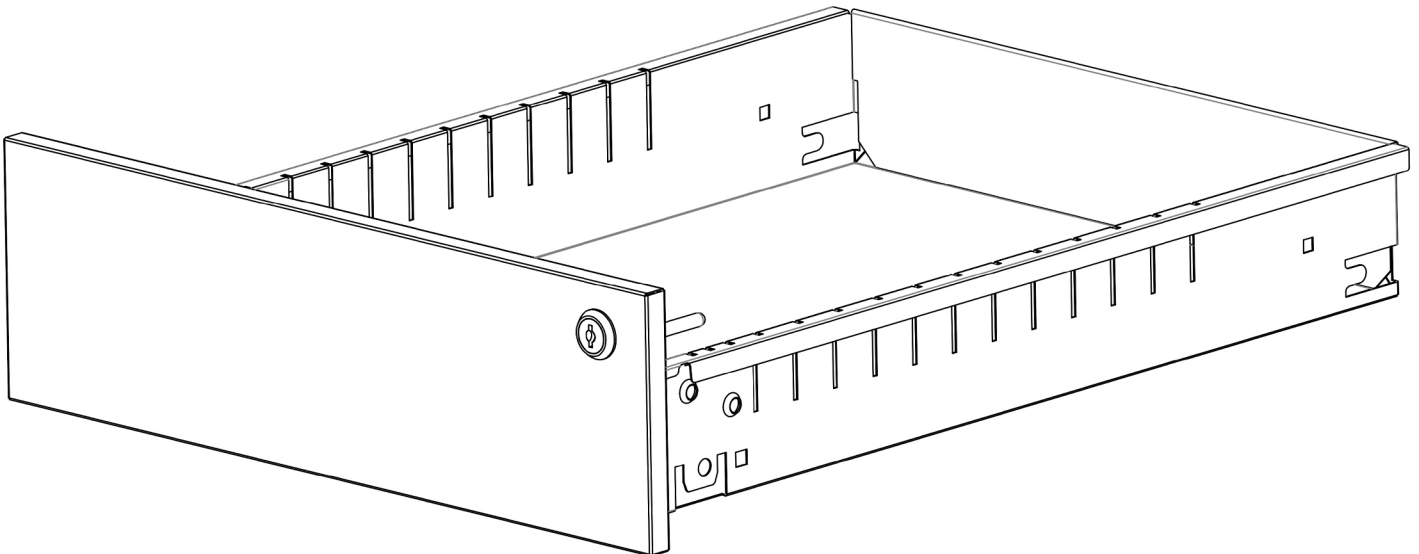
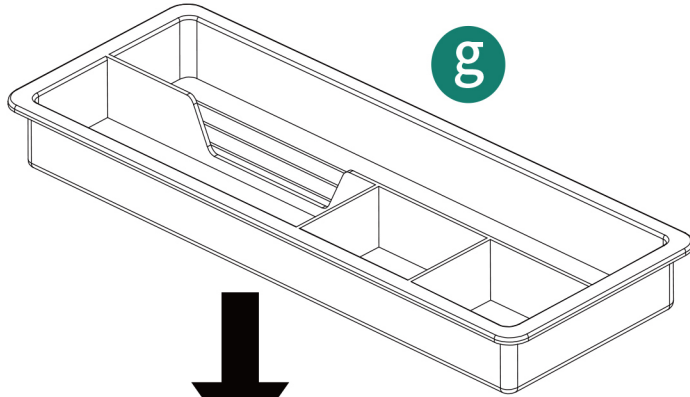

7

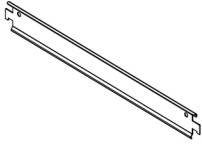

h 1pc

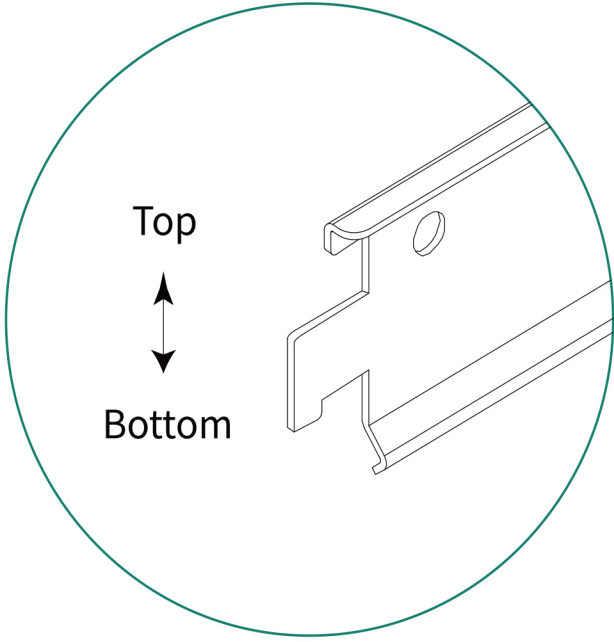
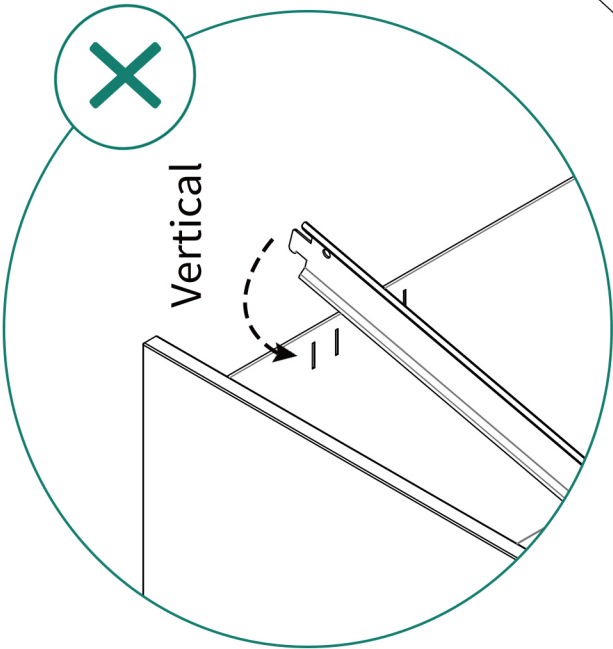
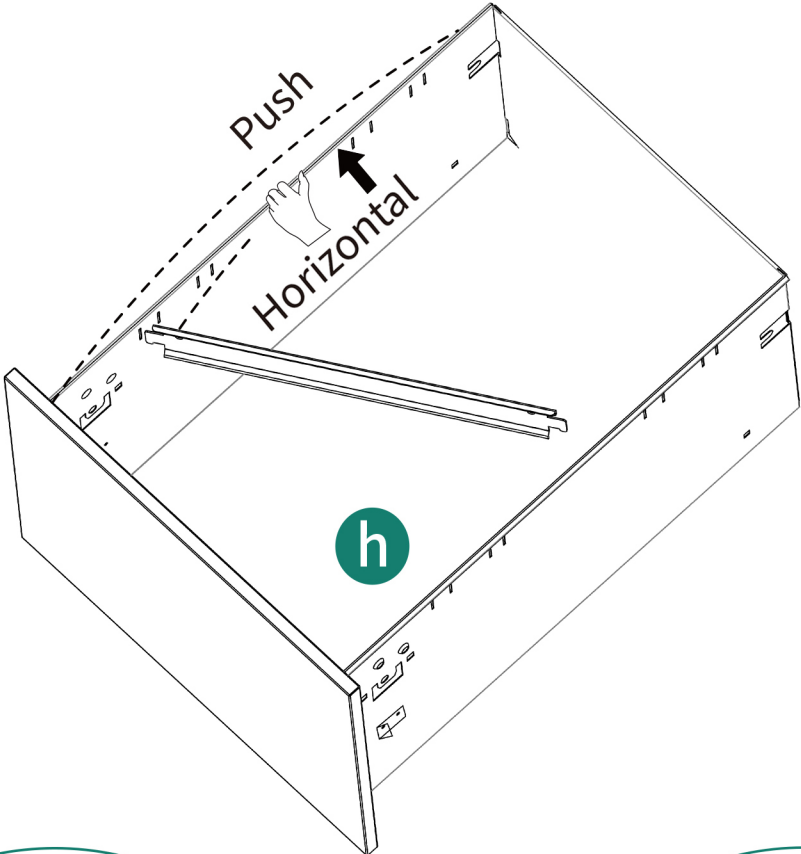

8

Lifting the hanging file bar slightly prior to removal makes removing or replacement easier.

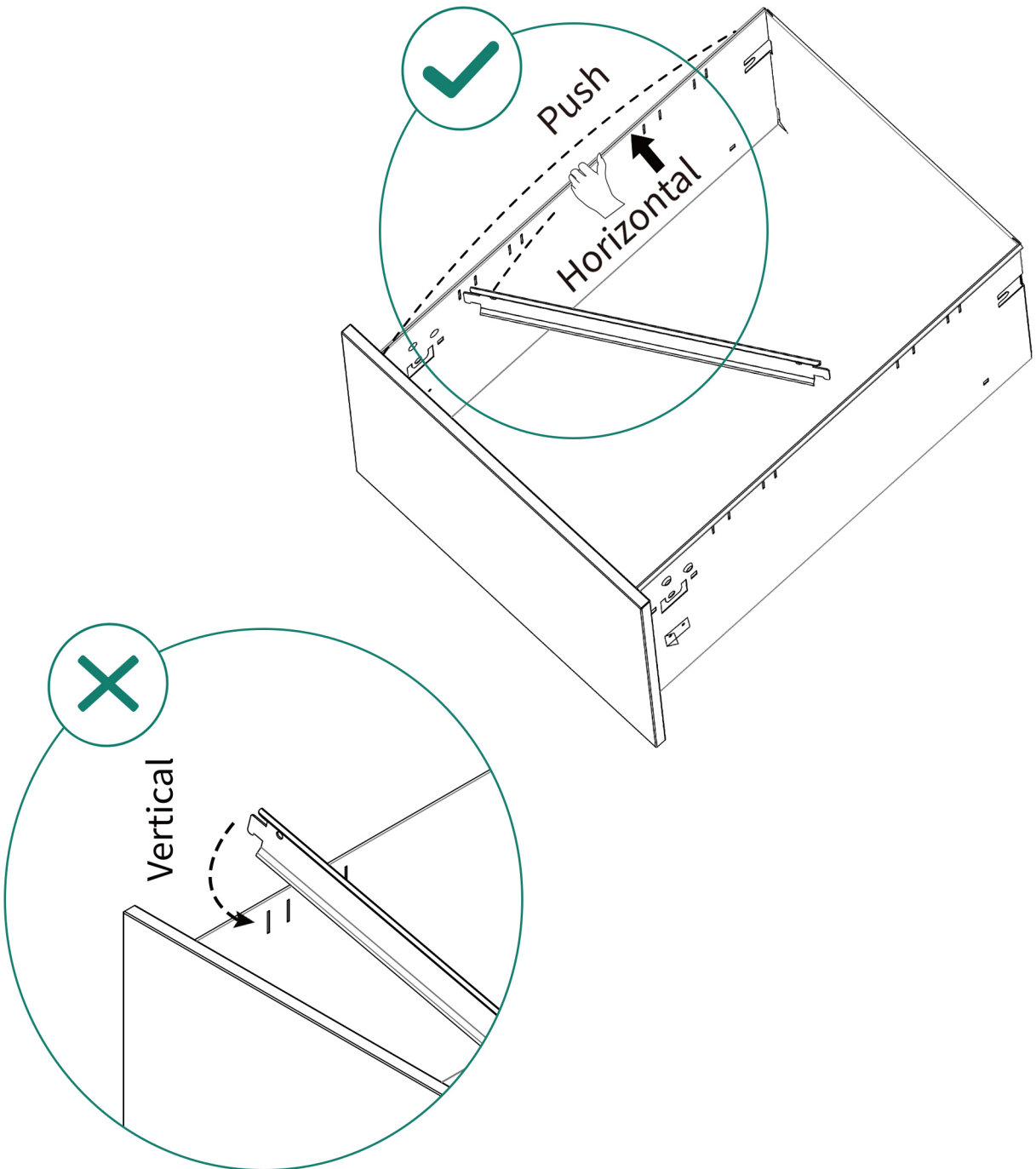

Instruction: 3 options available (Letter size, Legal size, A4 size)

Hanging file bar position 1-for Letter size file folders.

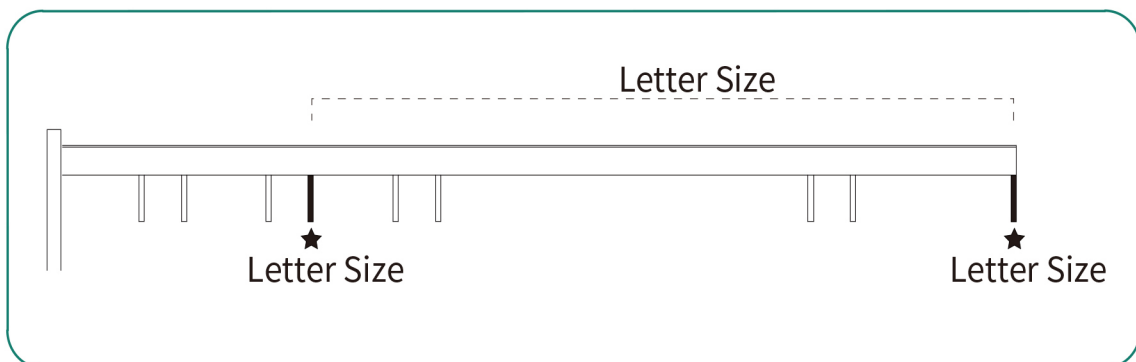
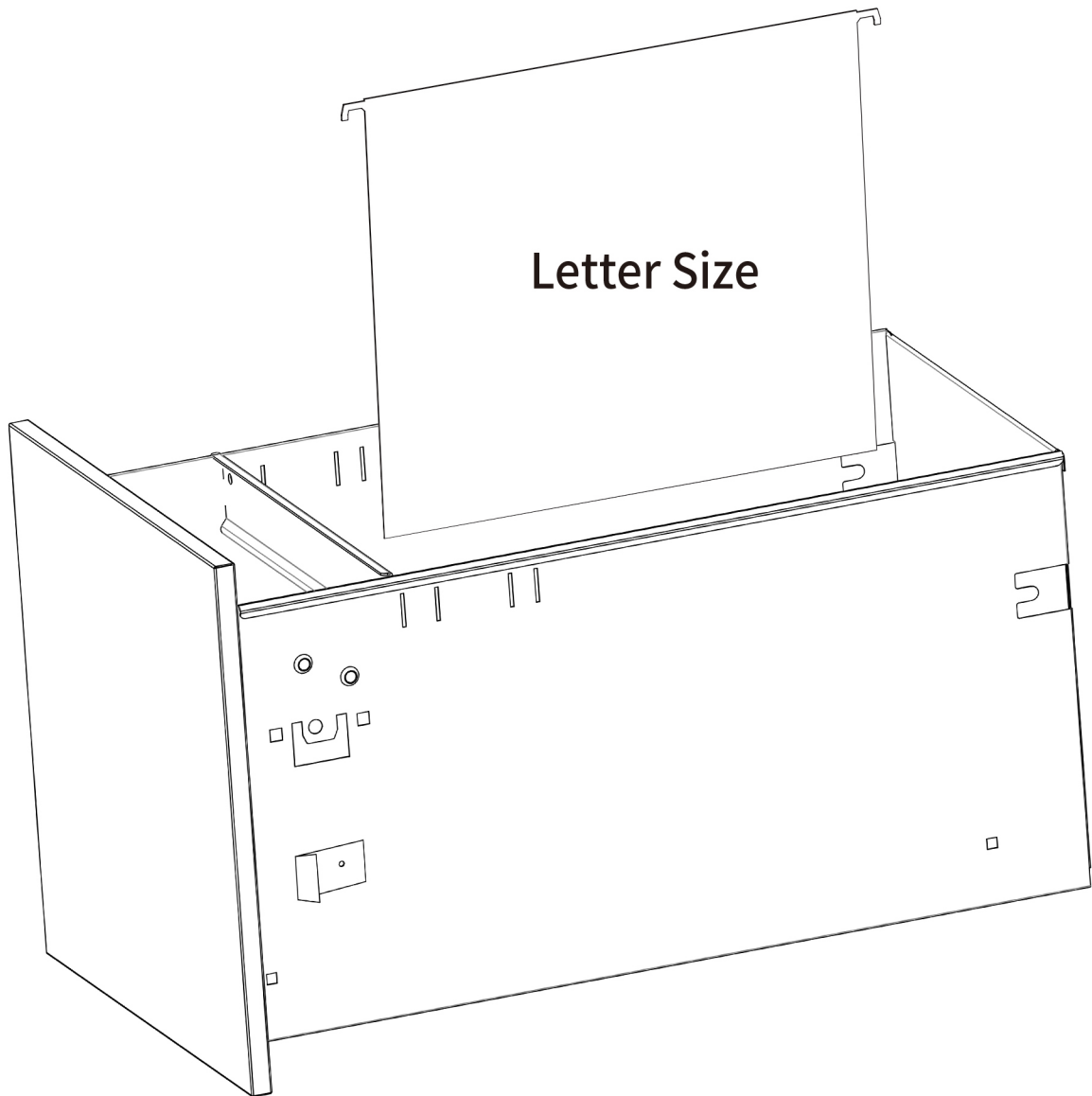

Hanging file bar position 2 – for A4 size file folders.

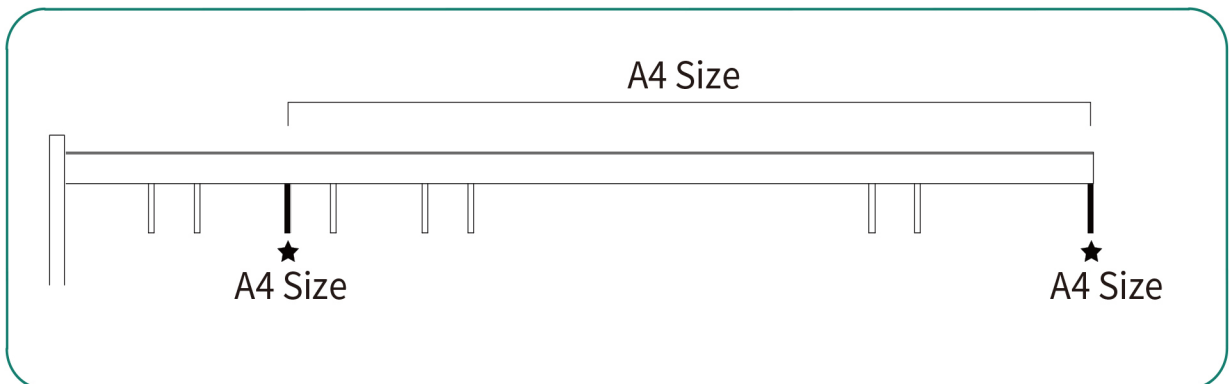
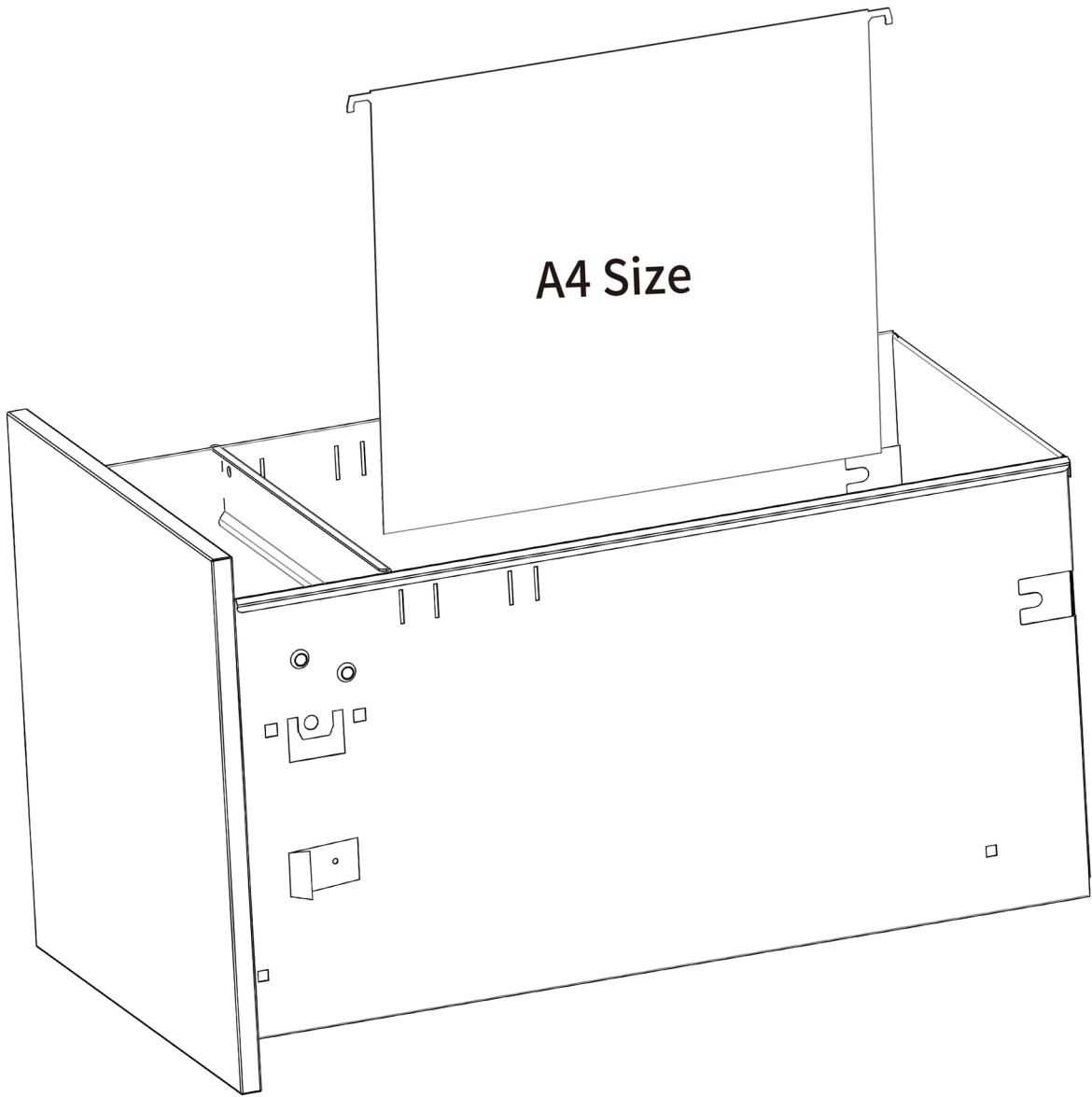

Hanging file bar position 3 – for Legal size file folders.

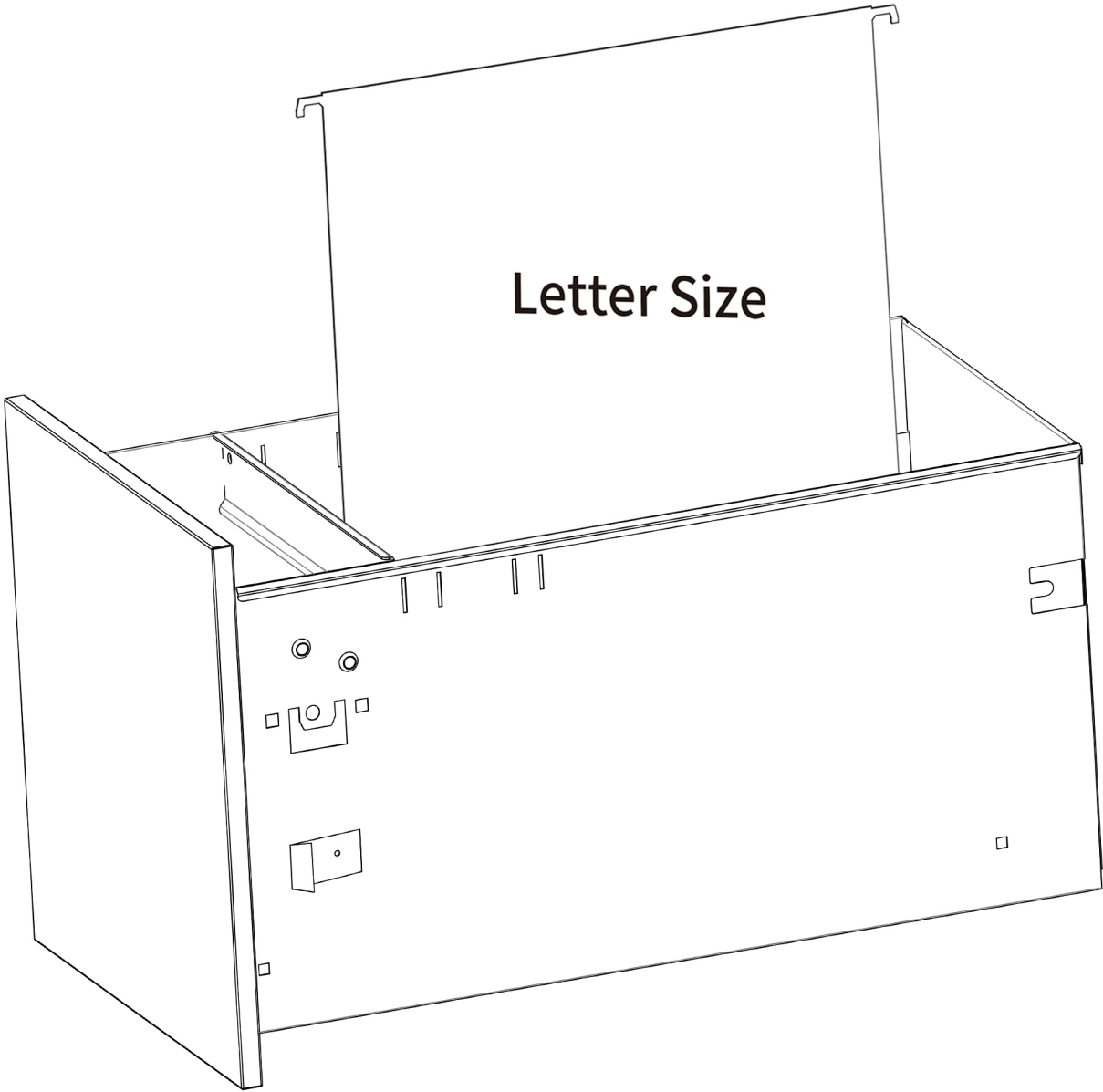

Does not include hanging file bar - for A4 size file folders.

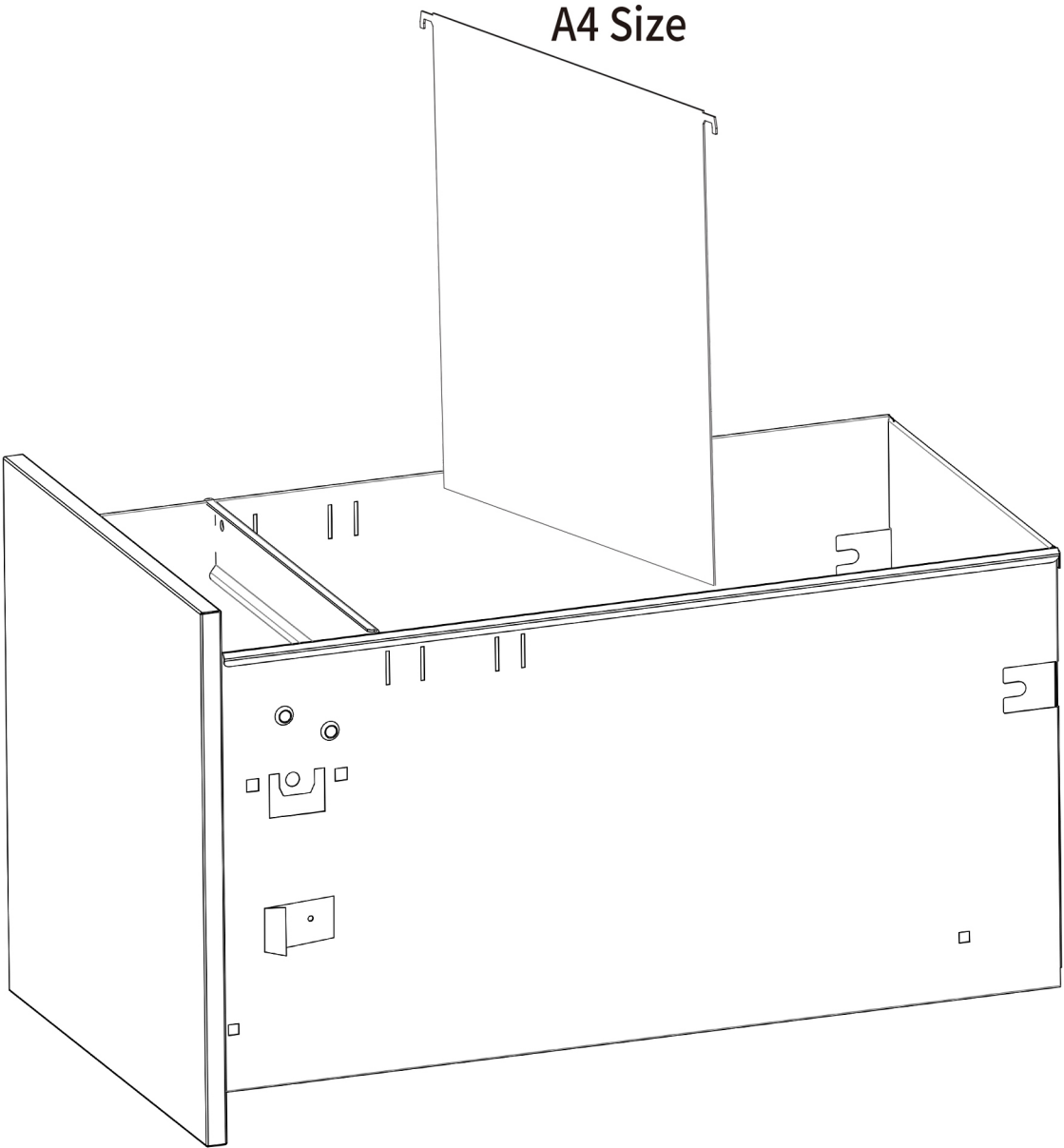

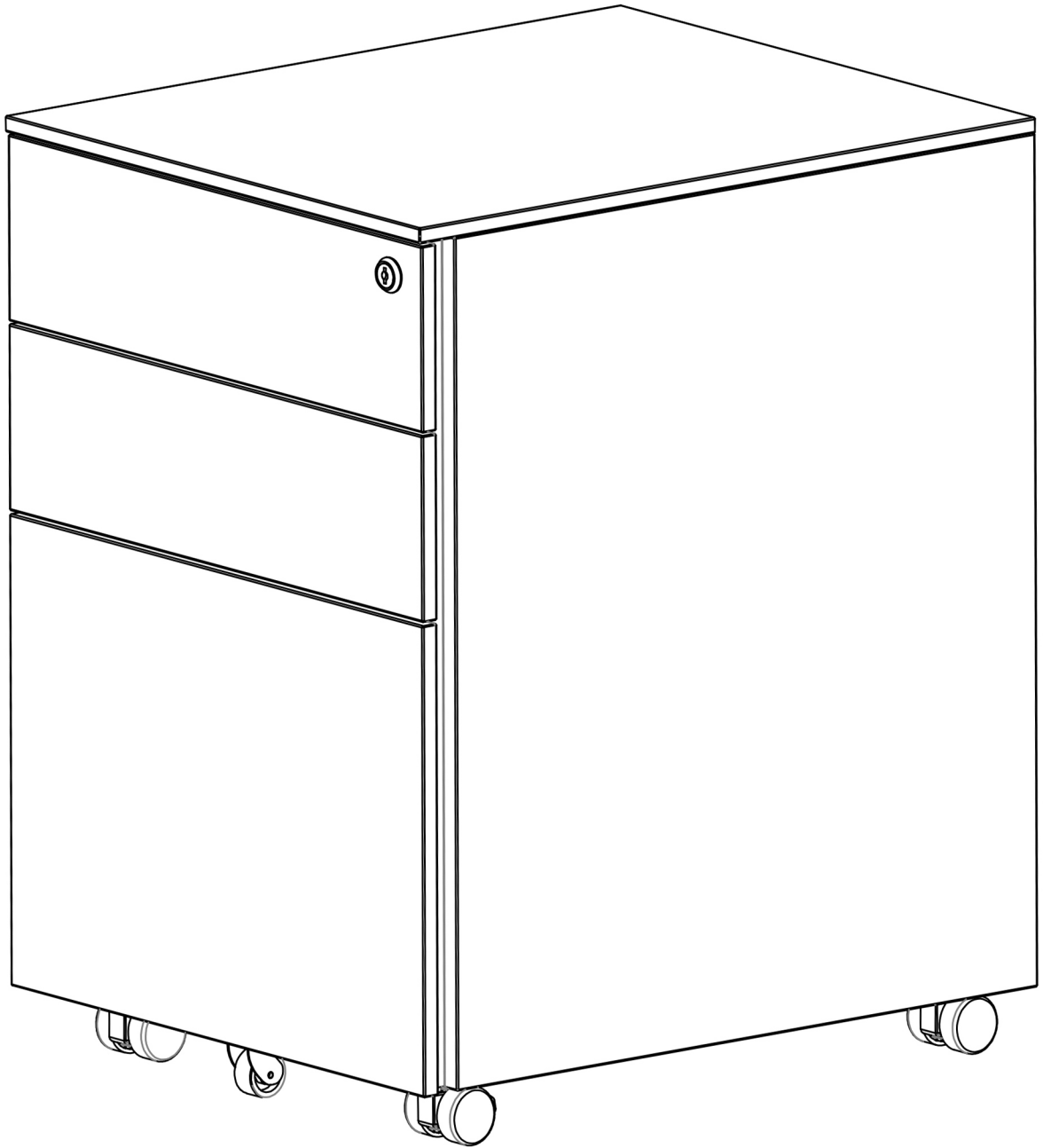

Installation Completed