

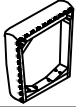







C162

ASSEMBLY INSTRUCTION

| PARTS | | | |
|-------|---|------------|------|
| 1 |  | CHAIR BACK | 1PC |
| 2 |  | SEAT | 1PC |
| 3 |  | FRONT LEG | 2PCS |

| HARDWARE LIST | | | |
|---------------|---|-----------------|------|
| A |  | Ø5/16" * 22mm | 9PCS |
| B |  | Ø5/16" | 9PCS |
| C |  | Ø5/16" * 3-1/2" | 4PCS |
| D |  | Ø5/16" * 2-1/4" | 5PCS |
| E |  | 4mm | 1PC |
| F |  | Ø10 * 30mm | 2PCS |

STEP 1

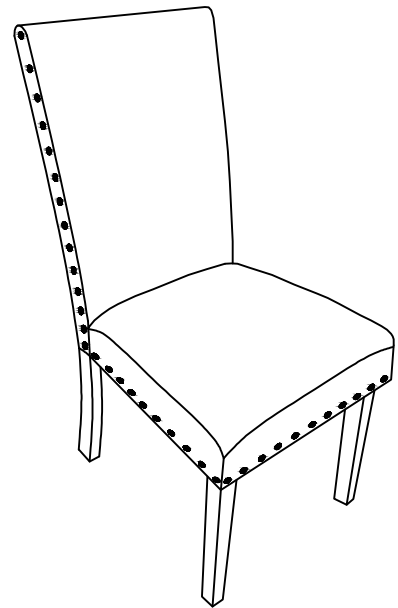
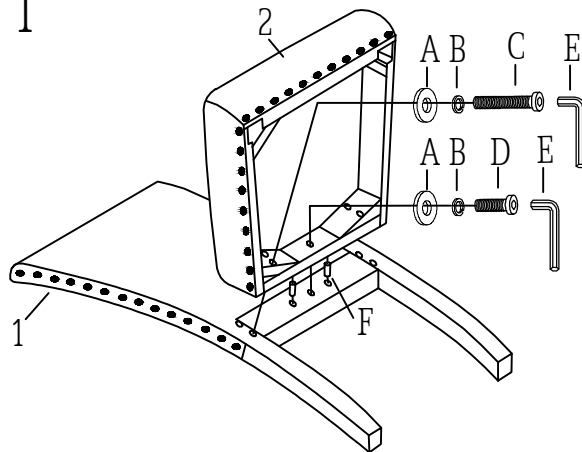

STEP 2

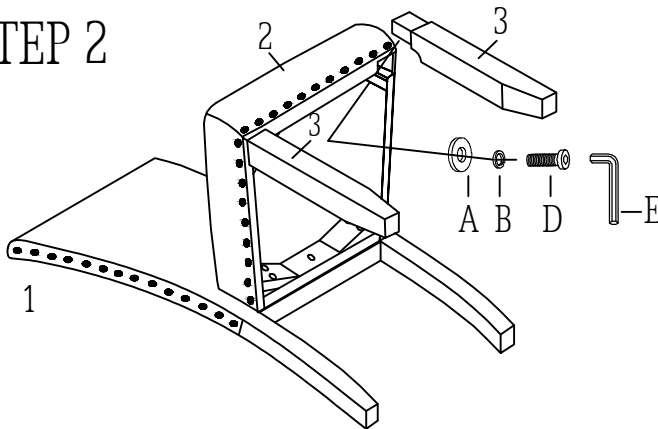

Do not Tighten ANY Bolts Until All Bolts Have Been Started, Stand the chair Upright on Flat Surface. Put Pressure on the chair and Rock it back and forth to adjust to level, Tighten All Bolts With Allen Wrench.