









C361/C161

ASSEMBLY INSTRUCTION

PARTS			
1		CHAIR BACK	1PC
2		SEAT	1PC
3		FRONT LEG	2PCS

HARDWARE LIST			
A		Ø5/16" * 22mm	9PCS
B		Ø5/16"	9PCS
C		Ø5/16" * 3-1/2"	4PCS
D		Ø5/16" * 2-1/4"	5PCS
E		4mm	1PC
F		Ø10 * 30mm	2PCS

STEP 1

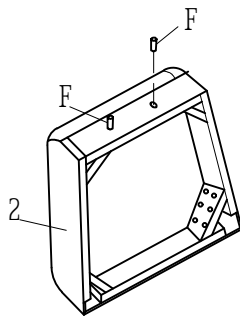

STEP 2

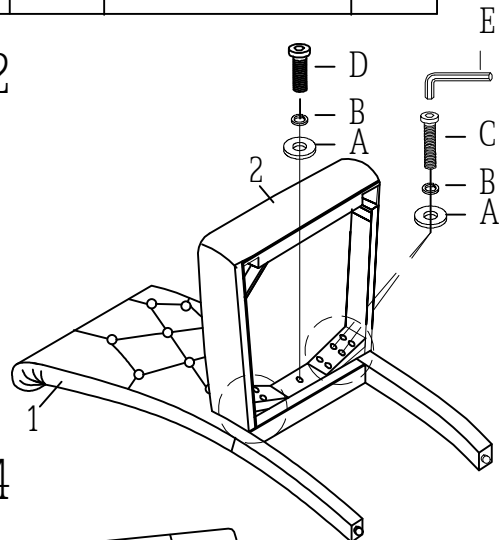

STEP 3

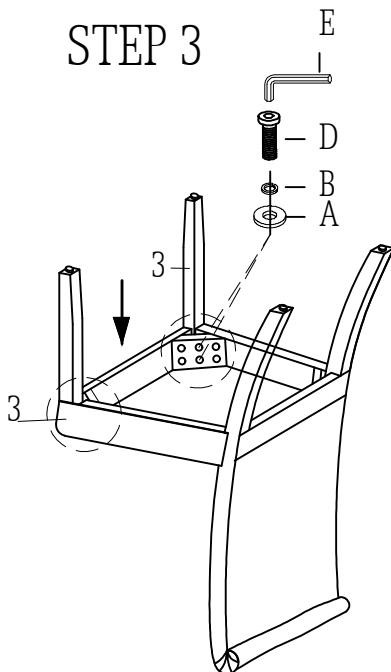

STEP 4

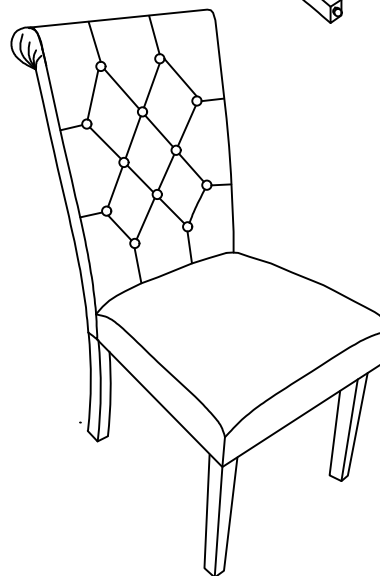

Do not Tighten ANY Bolts Until All Bolts Have Been Started, Stand the chair Upright on Flat Surface. Put Pressure on the chair and Rock it back and forth to adjust to level, Tighten All Bolts With Allen Wrench.