

Threshold must be level.

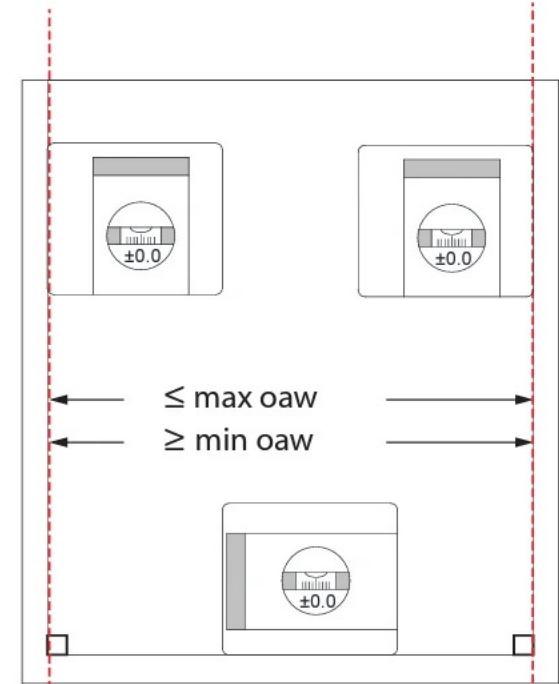
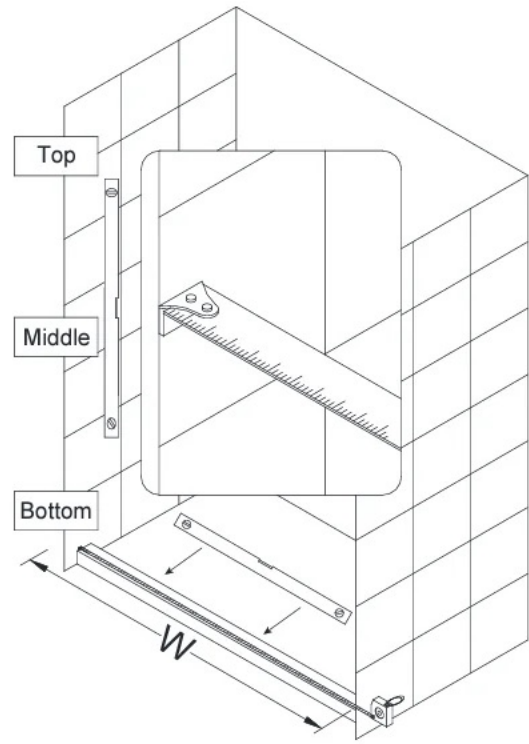
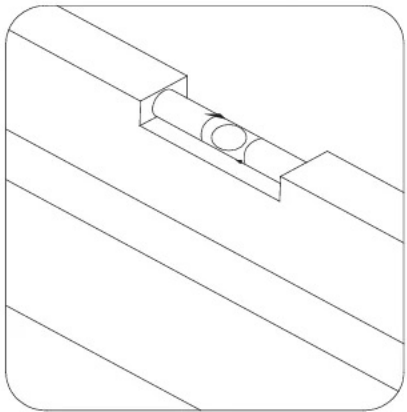

both walls plumb