

Installation video

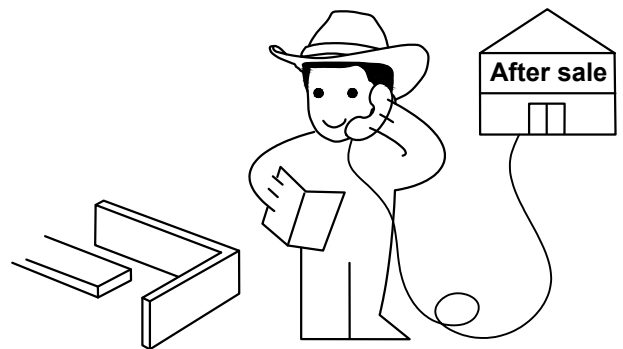

1×2pcs

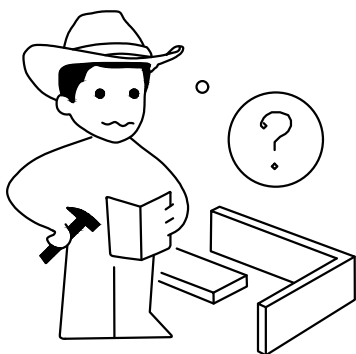
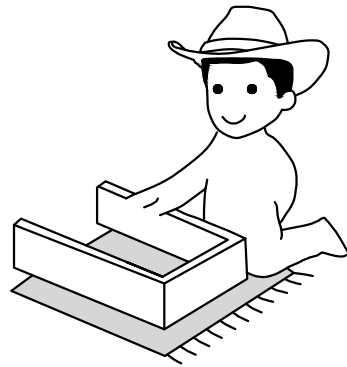
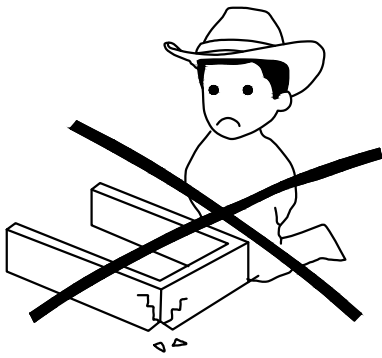
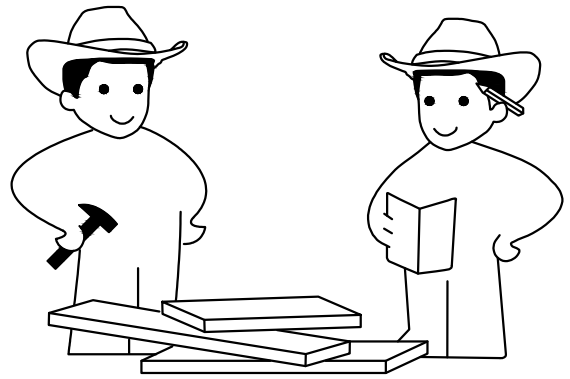
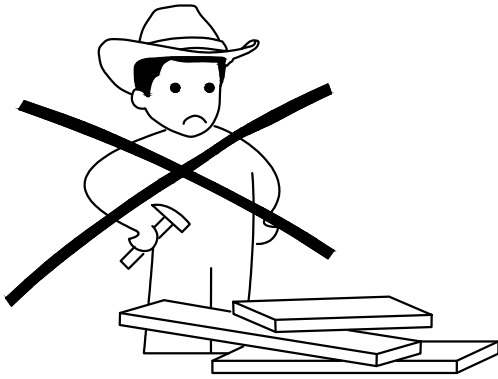
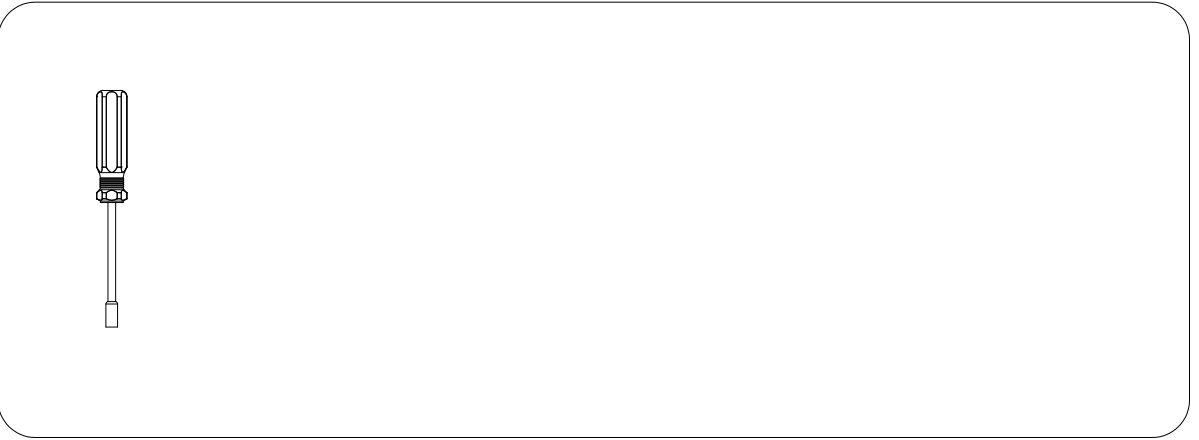
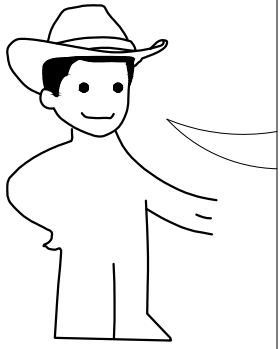
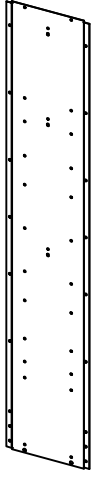

2×1pcs

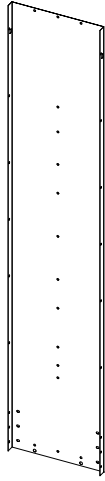

3×1pcs

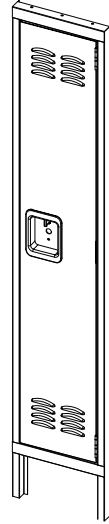

4×2pcs

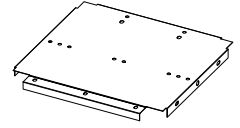

6×2pcs

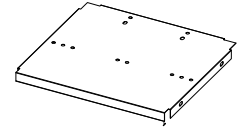

5×2pcs



A×76pcs

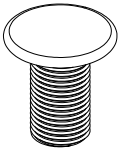

B×76pcs

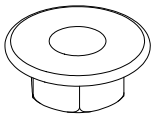

C×2pcs

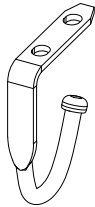

D×1pcs

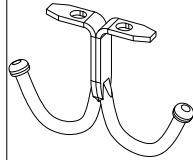

Ex1pcs

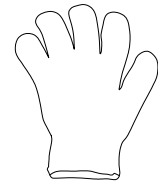
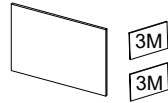

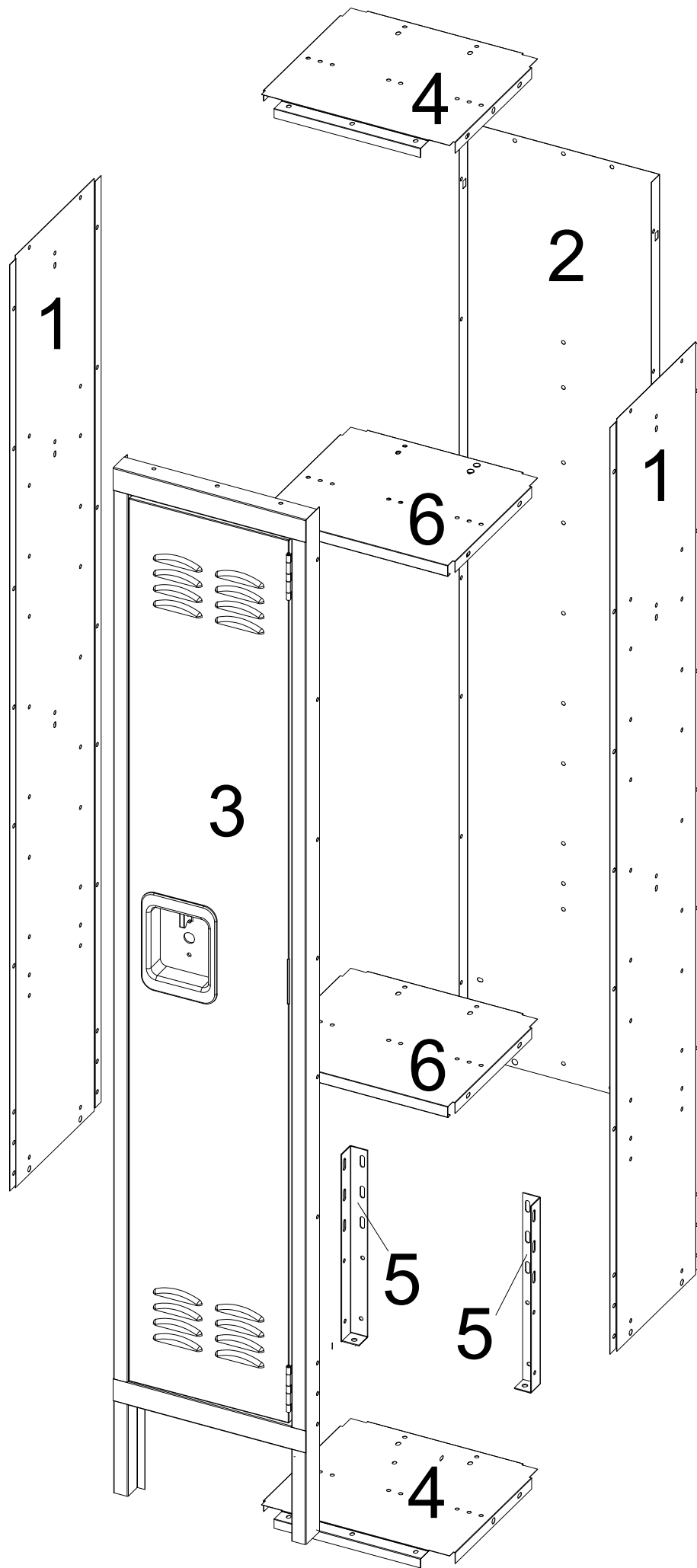

1

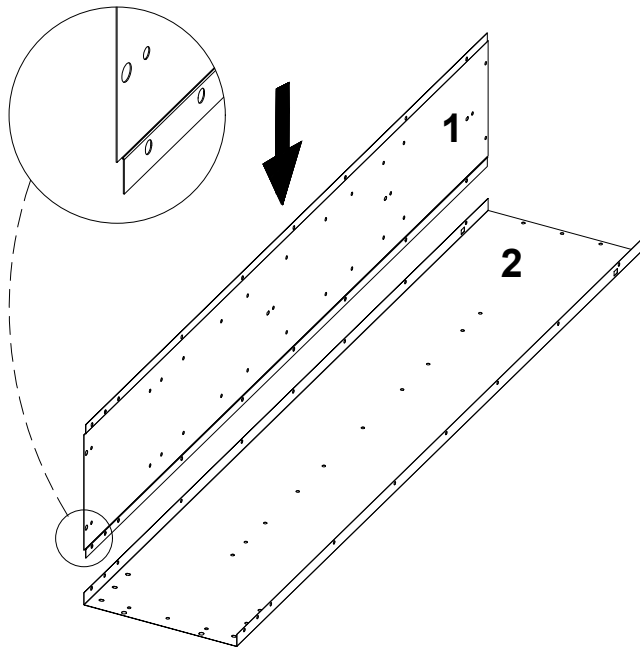

put six bolts and nuts to hold part 1 and 2 into place.

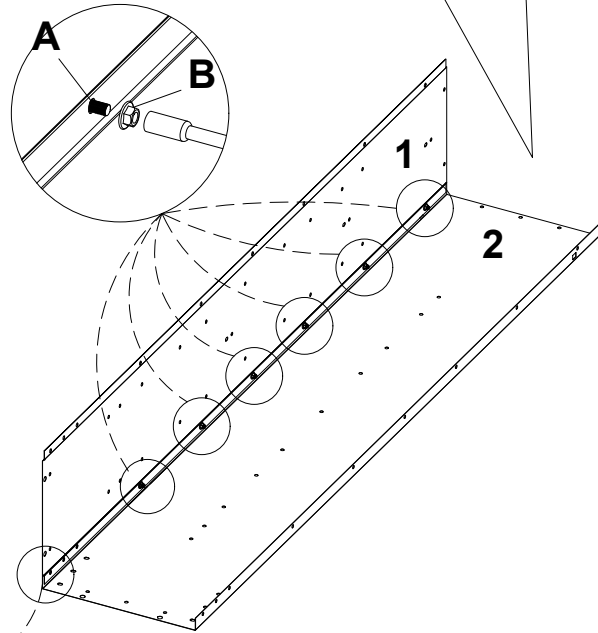

A×6



B×6

2

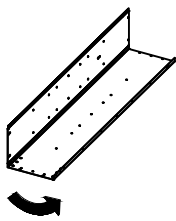

put six bolts and nuts to hold part 1 and 2 into place.

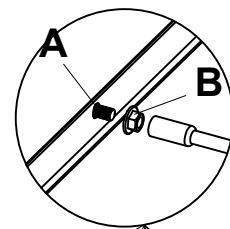
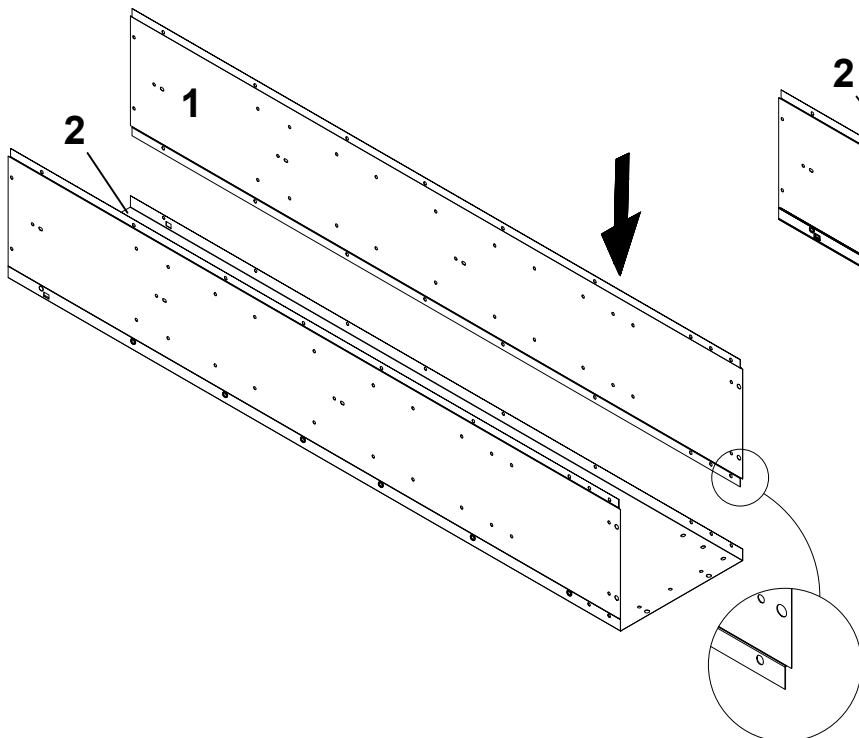

A×6



B×6

3

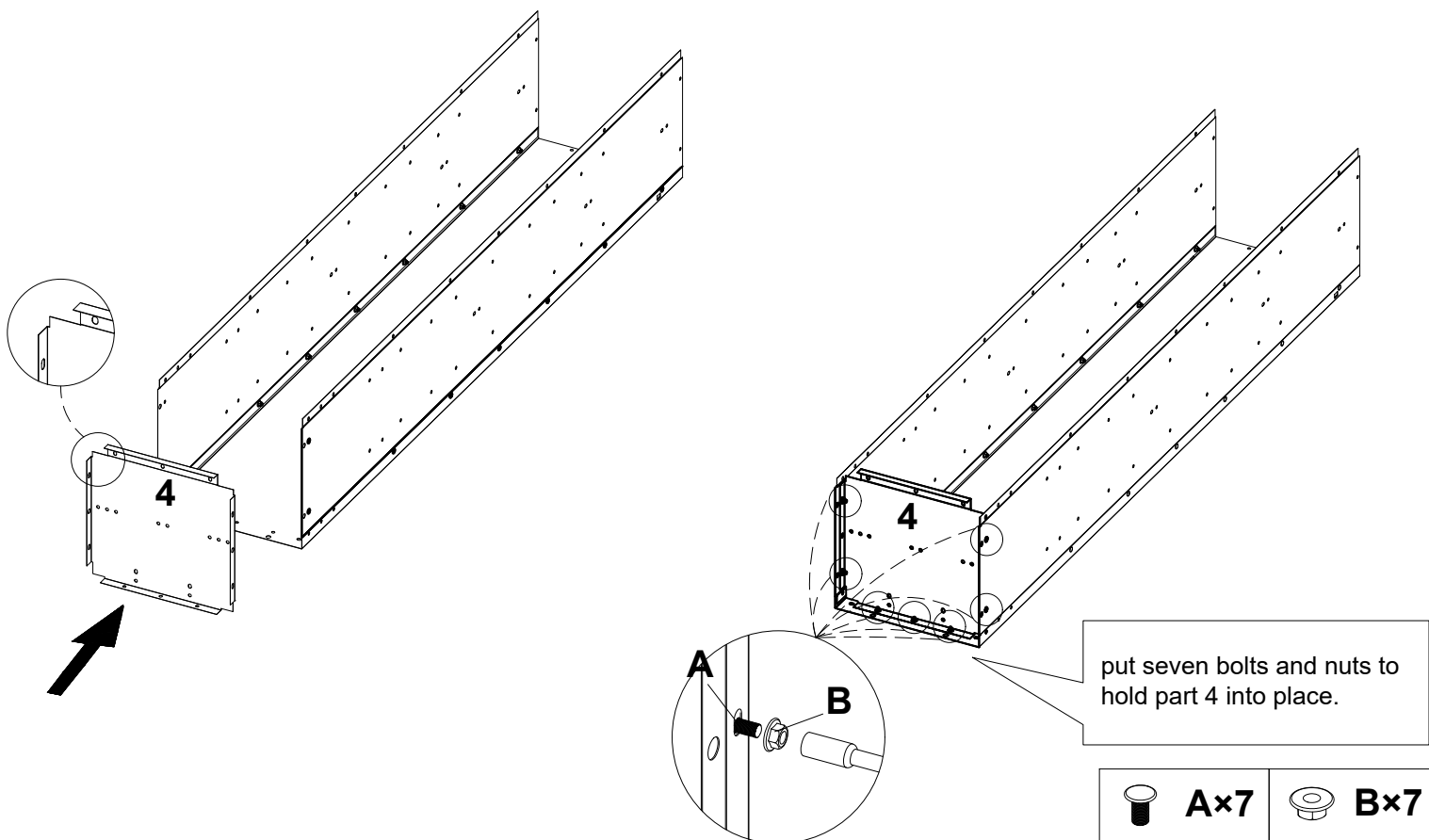

4

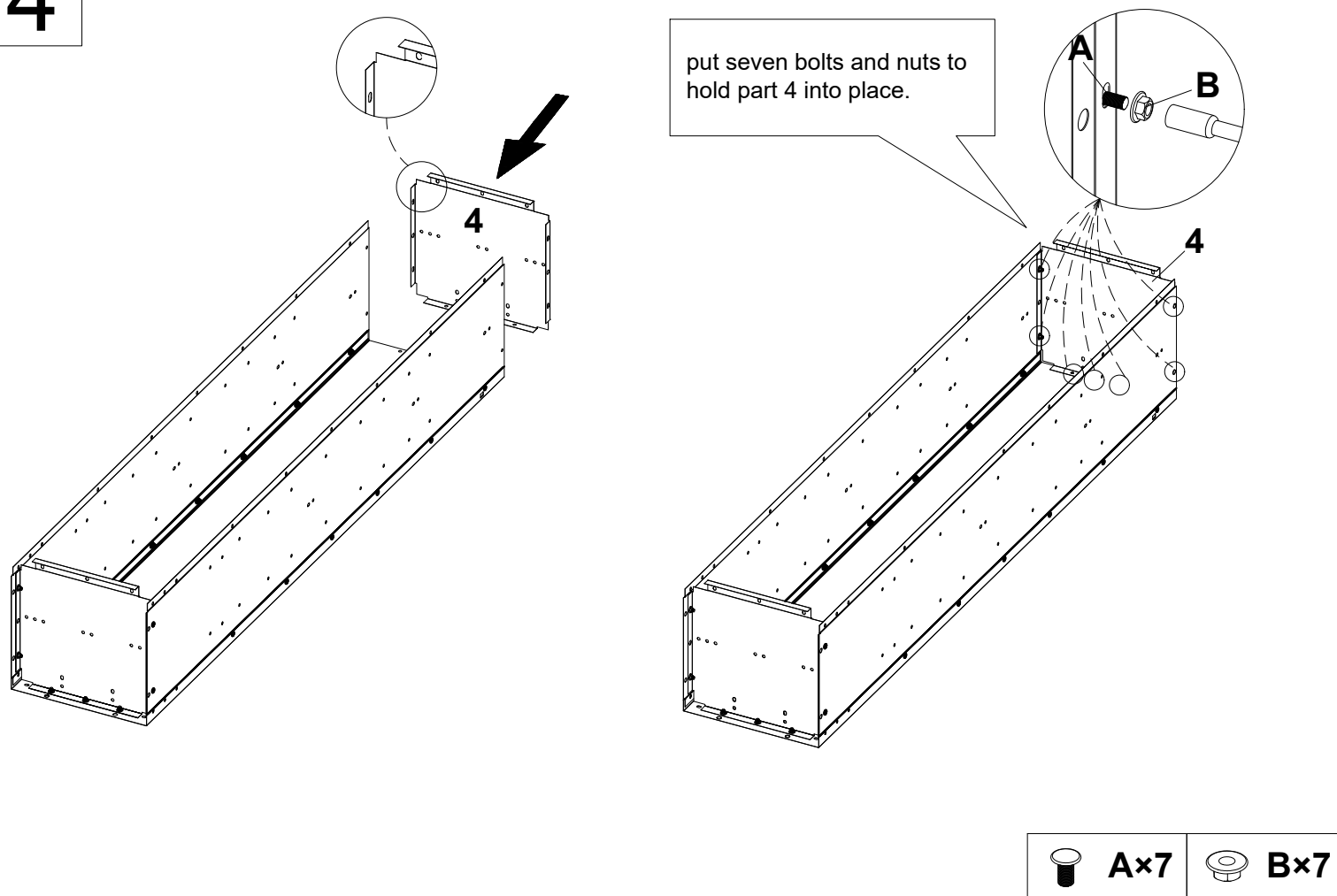

5

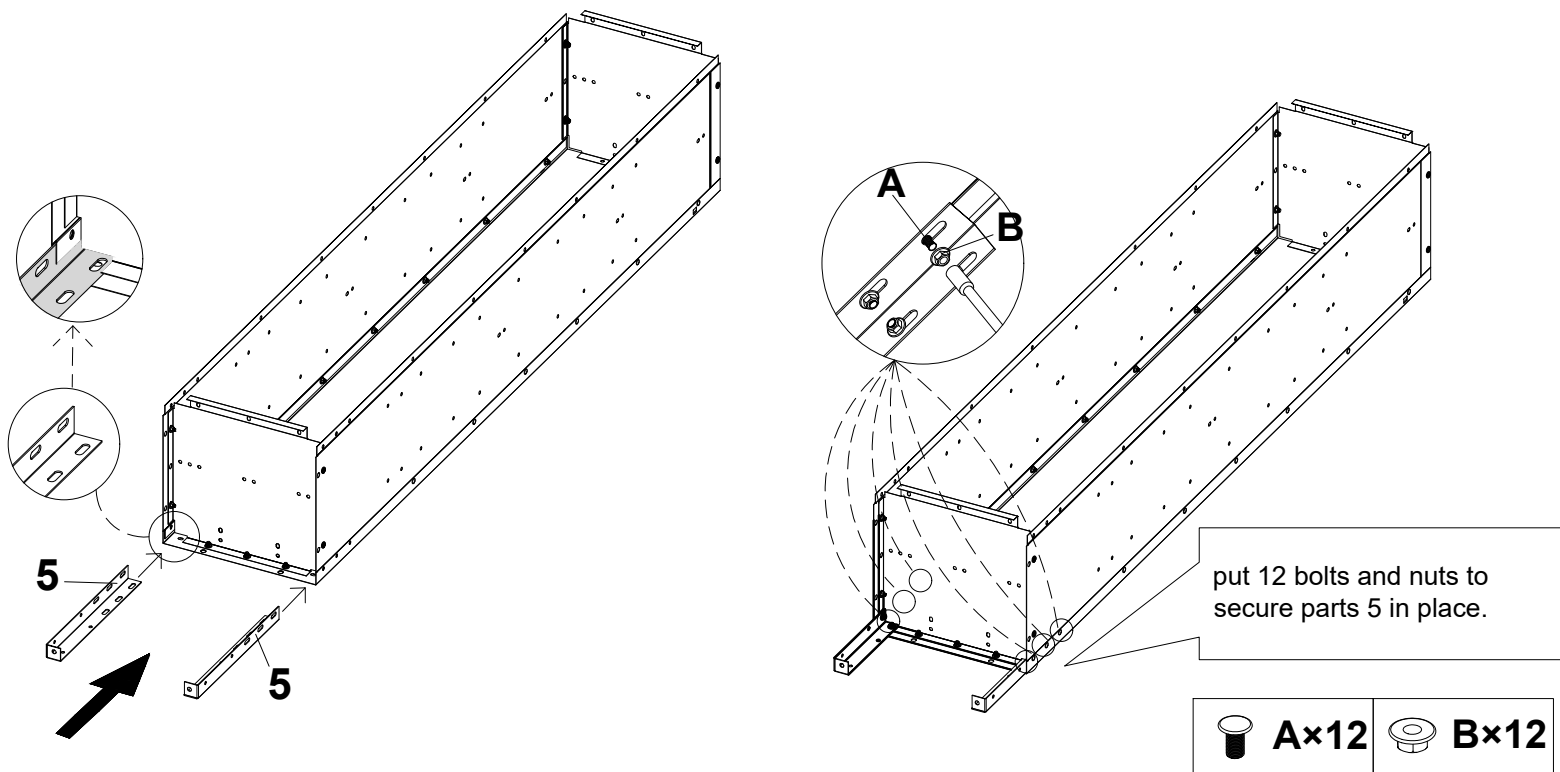

6

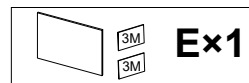
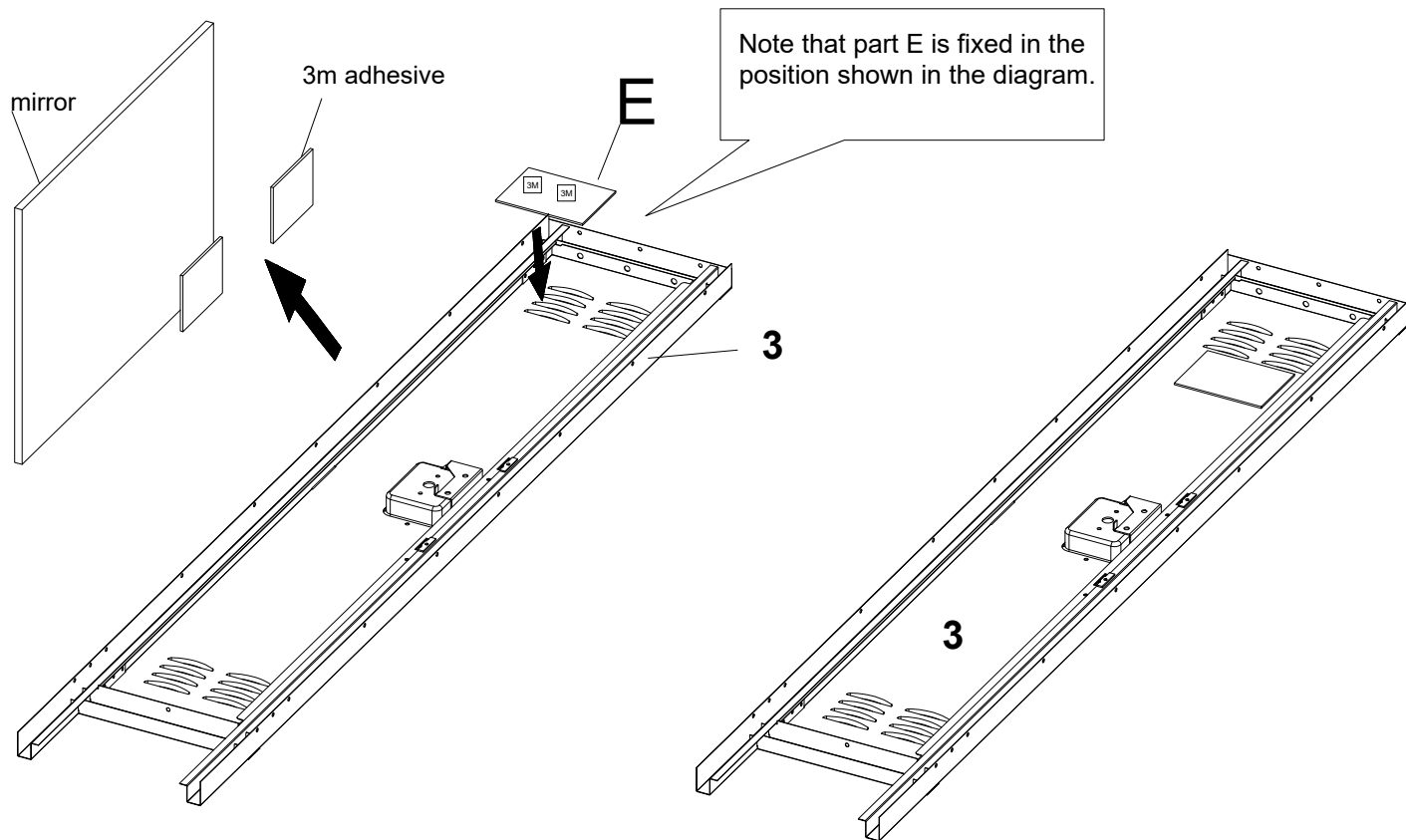

7

3

put eighteen bolts  
and nuts to hold part  
3 into place.

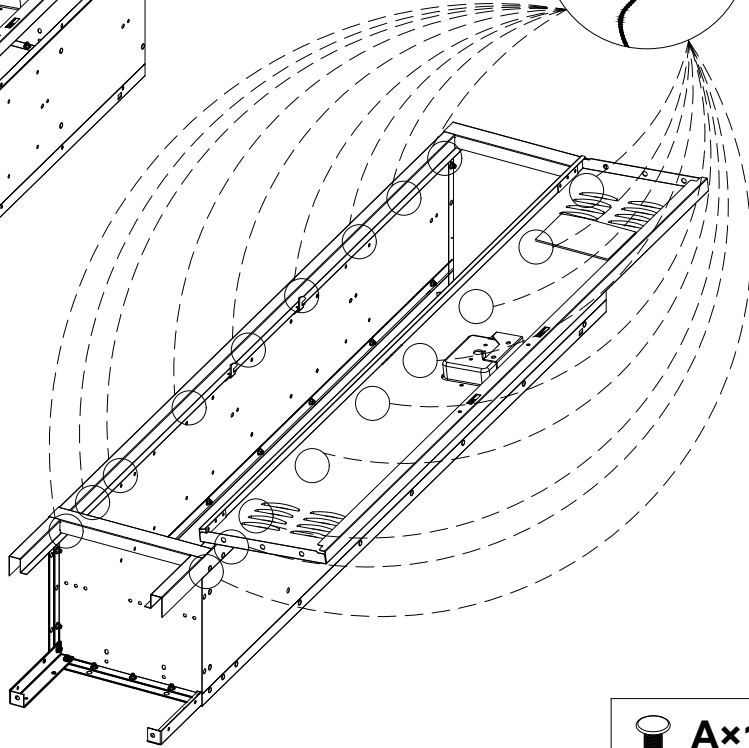
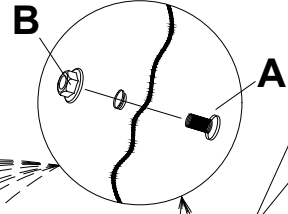
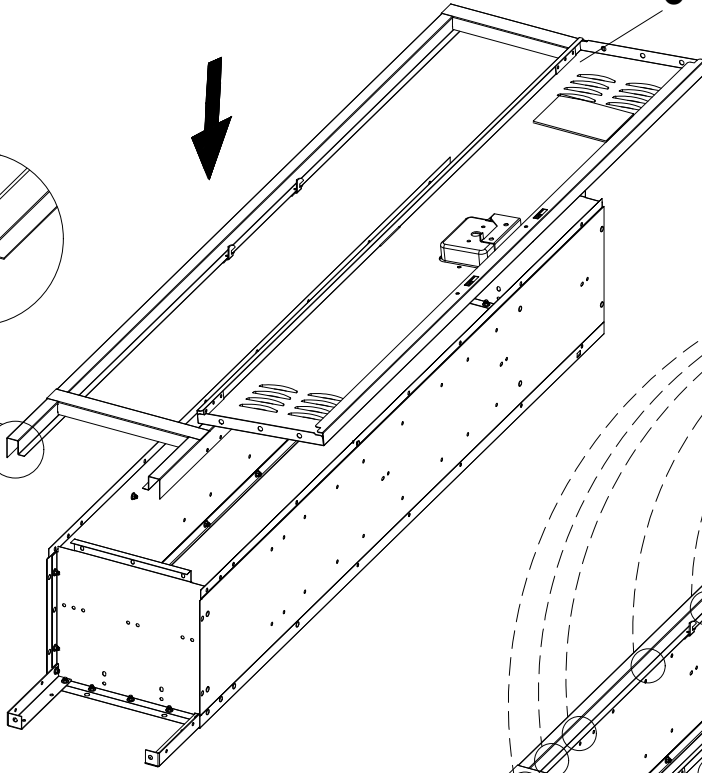
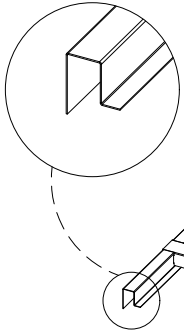

A×18



B×18

8

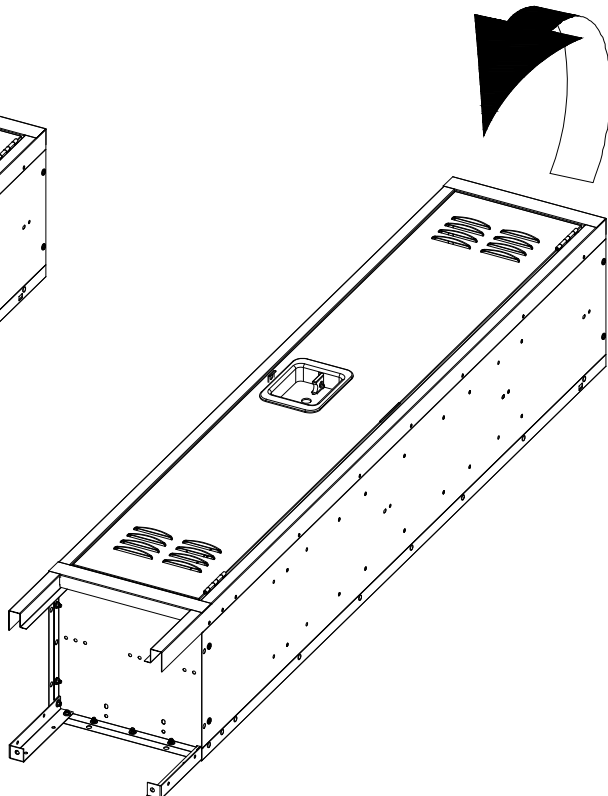
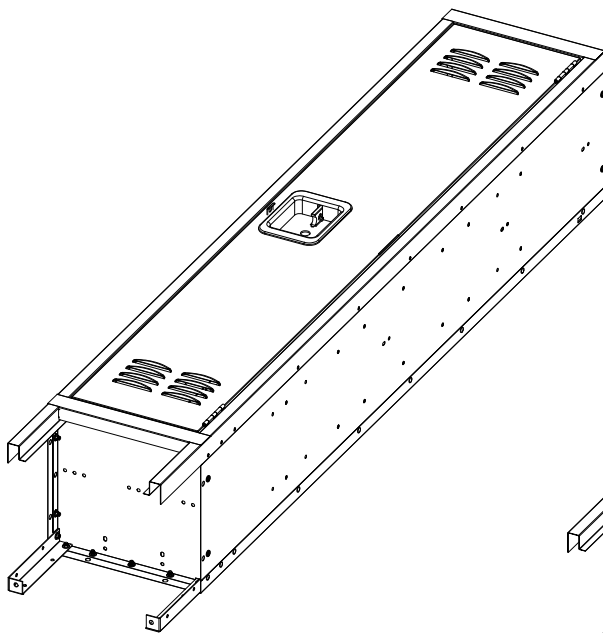



9

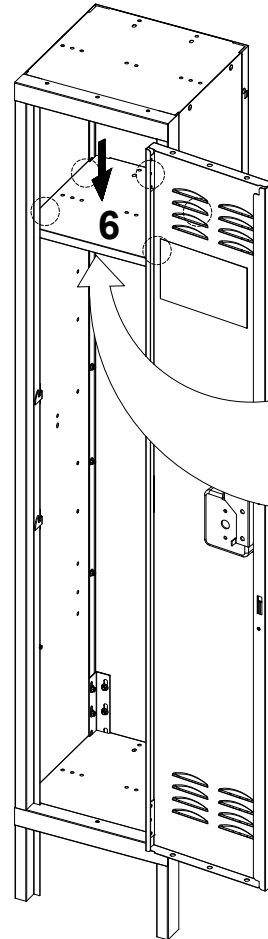
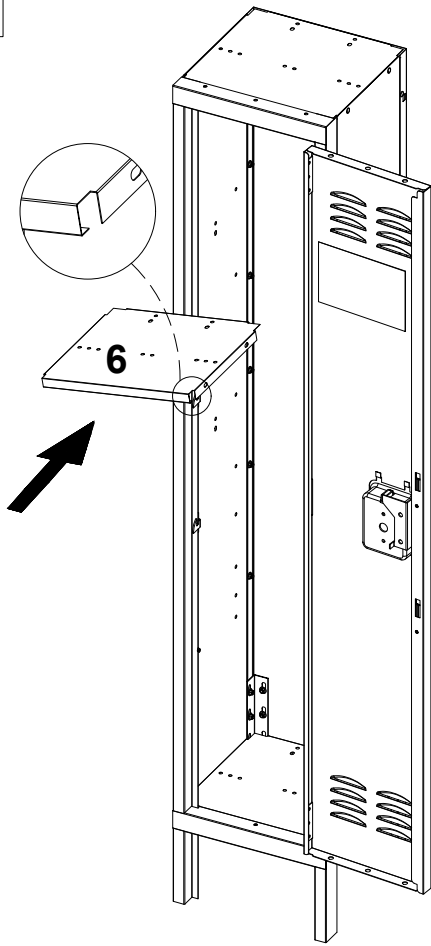

put five bolts and nuts to hold part 6 into place.

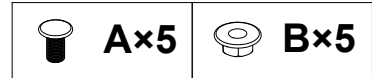

10

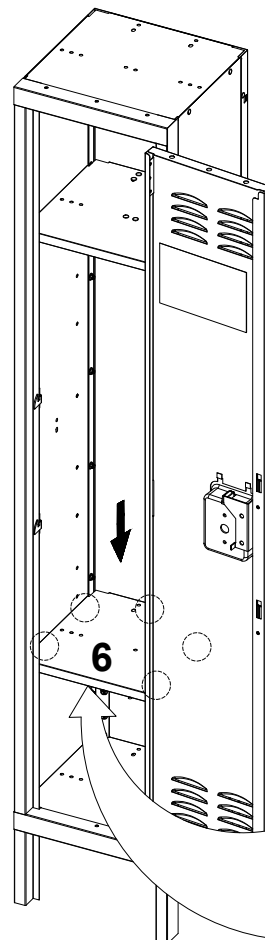
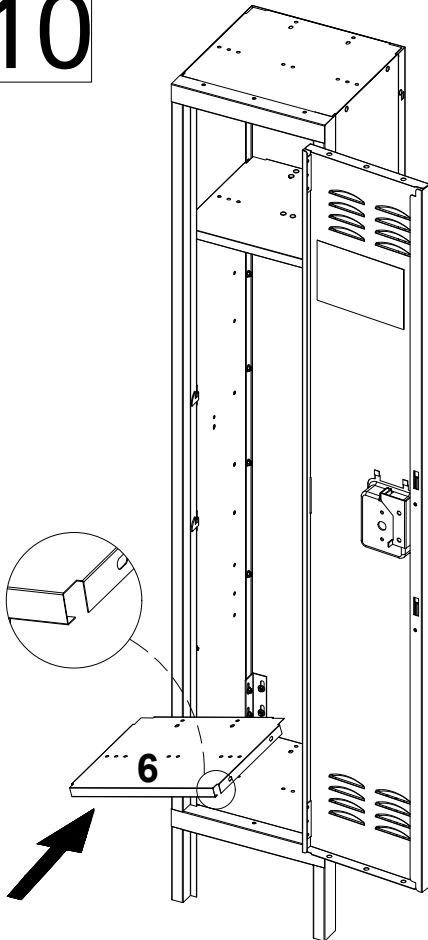

put five bolts and nuts to hold part 6 into place.

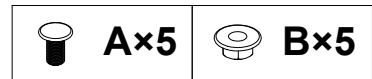

# 11

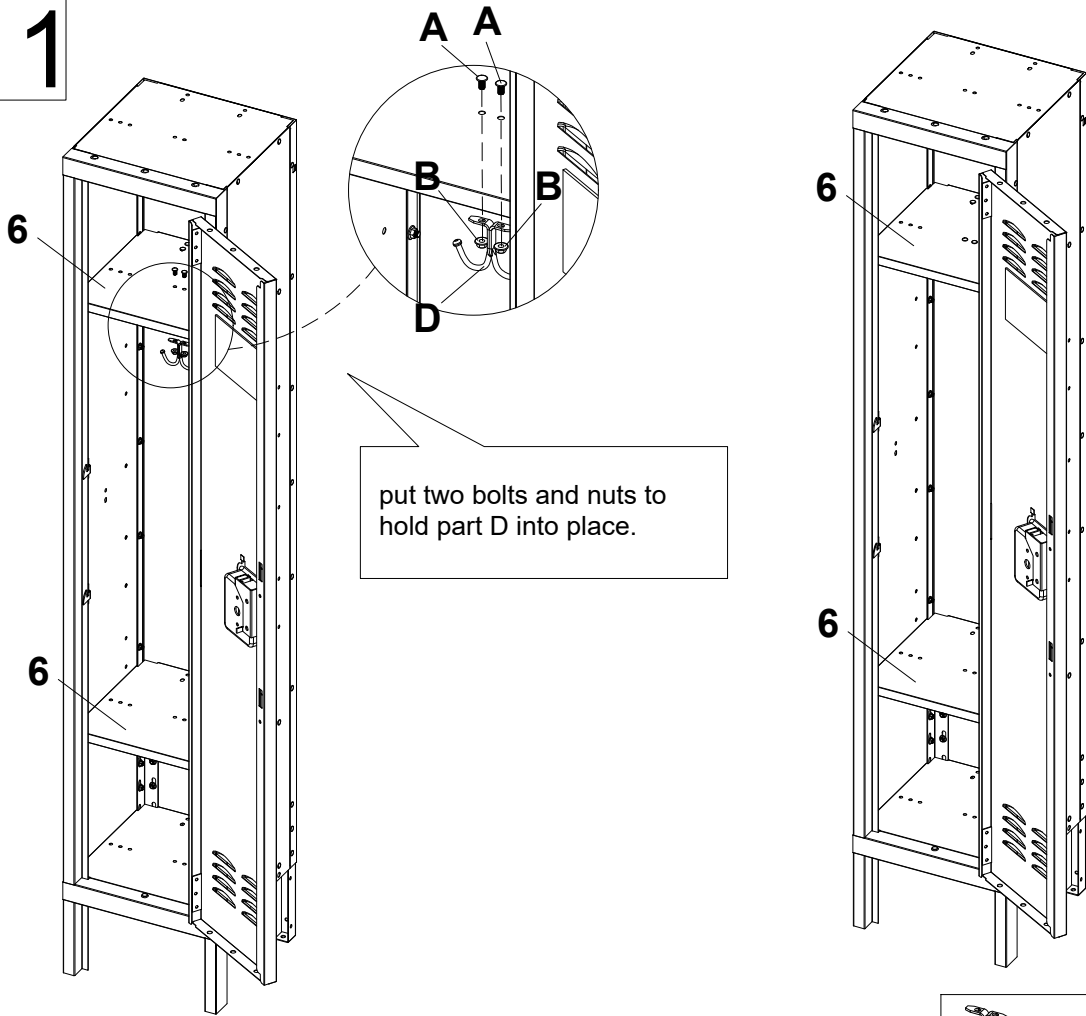

put two bolts and nuts to hold part D into place.

 D×1	 A×2	 B×2
---	---	---

# 12

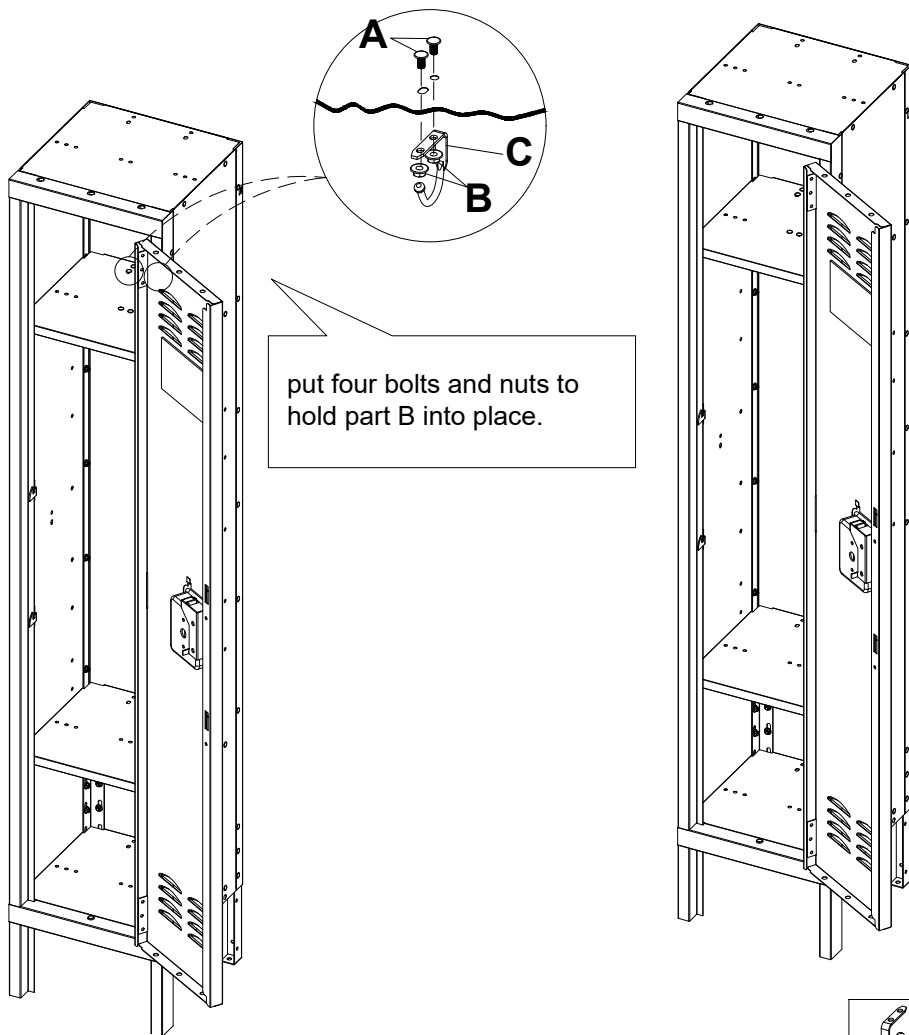

put four bolts and nuts to hold part B into place.

 C×2	 A×4	 B×4
---	---	---

# 13

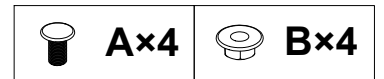
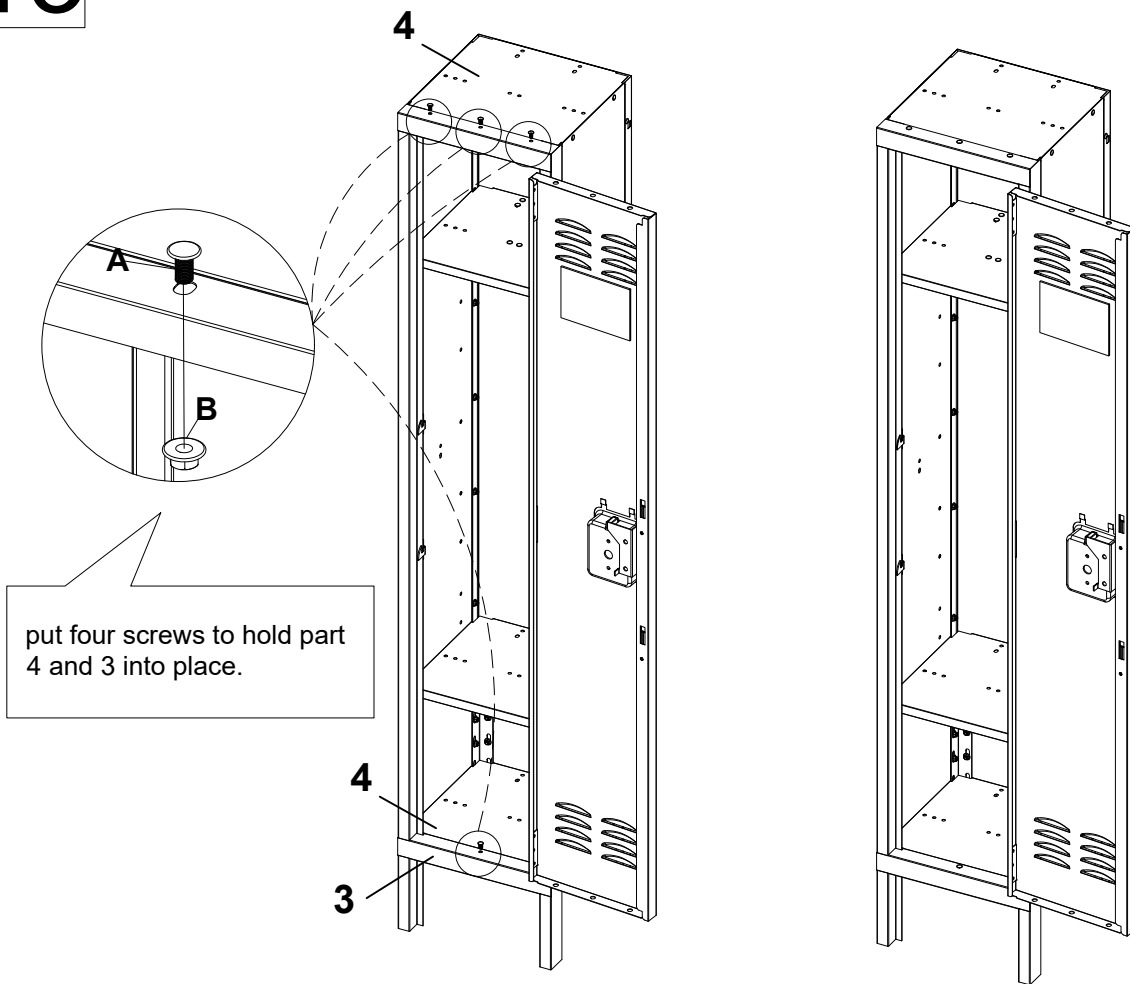

# 14

