

# Assembly Instruction

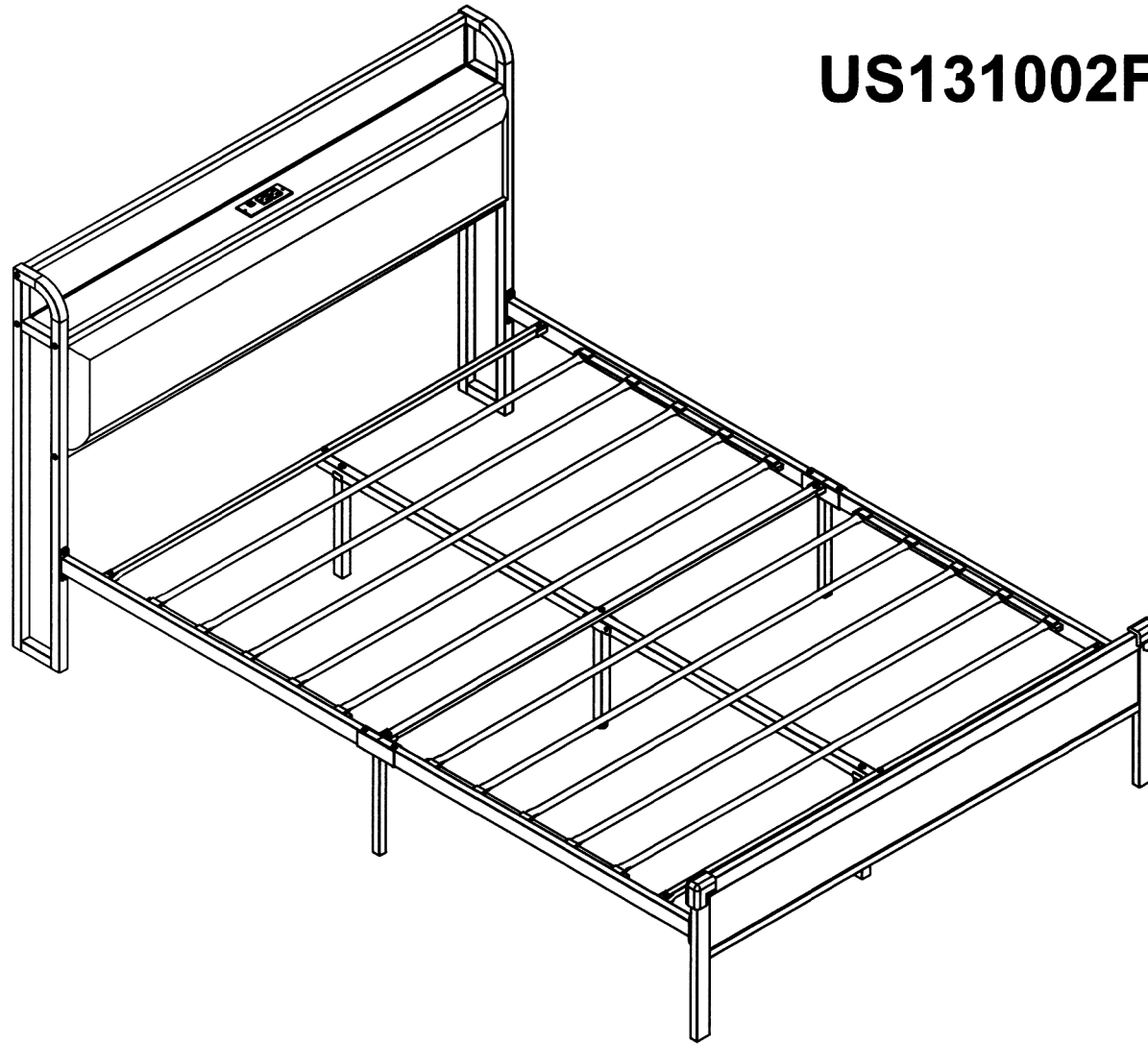







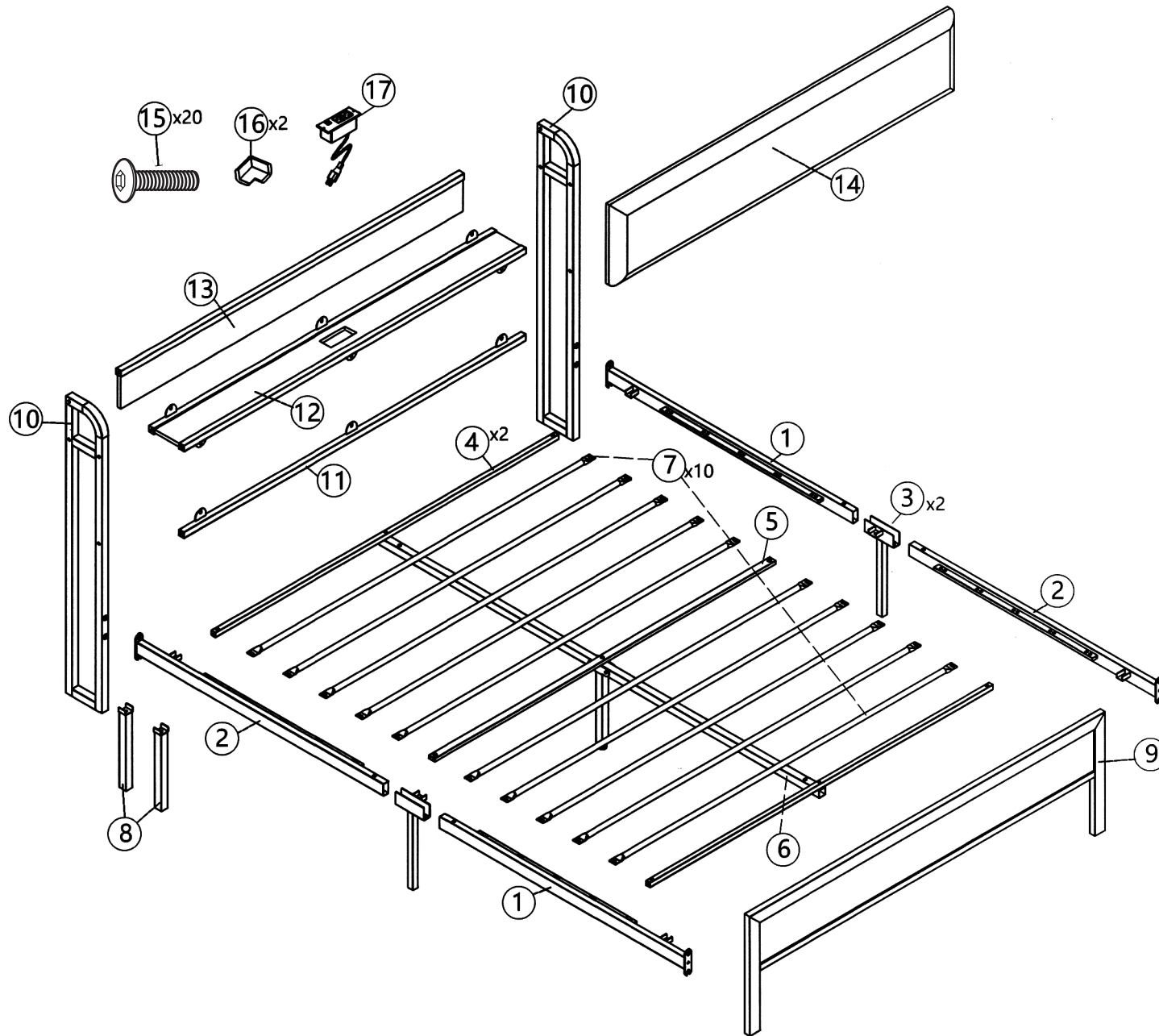



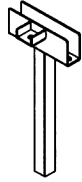
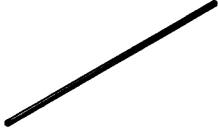
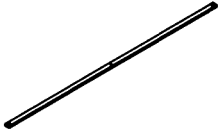
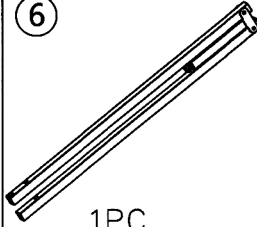
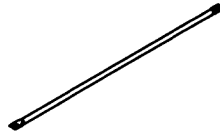

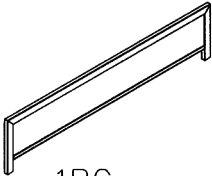
**US131002F/Q**

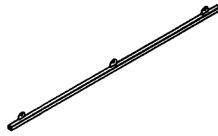

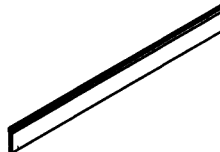
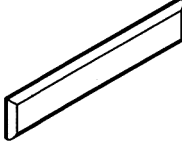
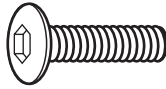
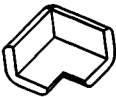
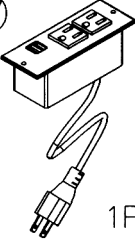
**Please don't tighten the screws completely and go back later for a final tightening of all the screws after pieces are aligned with each other.**

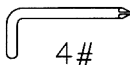
# Part list

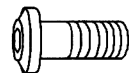
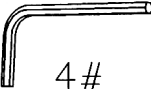

<p>①</p>  <p>2PCS</p>	<p>②</p>  <p>2PCS</p>	<p>③</p>  <p>2PCS</p>	<p>④</p>  <p>2PCS</p>	<p>⑤</p>  <p>1PC</p>	<p>⑥</p>  <p>1PC</p>	<p>⑦</p>  <p>10PCS</p>	<p>⑧</p>  <p>2PCS</p>
<p>⑨</p>  <p>1PC</p>	<p>⑩</p>  <p>2PCS</p>	<p>⑪</p>  <p>1PC</p>	<p>⑫</p>  <p>1PC</p>	<p>⑬</p>  <p>1PC</p>	<p>⑭</p>  <p>1PC</p>	<p>⑮</p>  <p>20PCS</p>	<p>⑯</p>  <p>2PCS</p>
<p>⑰</p>  <p>1PC</p>							
<p><b>A</b></p>  <p>M4*15 2PCS</p>	<p><b>B</b></p>  <p>4# 1PC</p>	<p><b>C</b></p>  <p>M6*12 9PCS</p>	<p><b>D</b></p>  <p>M6*25 24PCS</p>	<p><b>E</b></p>  <p>M6*35 8PCS</p>	<p><b>F</b></p>  <p>M8*45 7PCS</p>	<p><b>G</b></p>  <p>M8*16 10PCS</p>	<p><b>H</b></p>  <p>4# 1PC</p>

Step:1

 M6\*35 E X6PCS

 4# H X 1PC

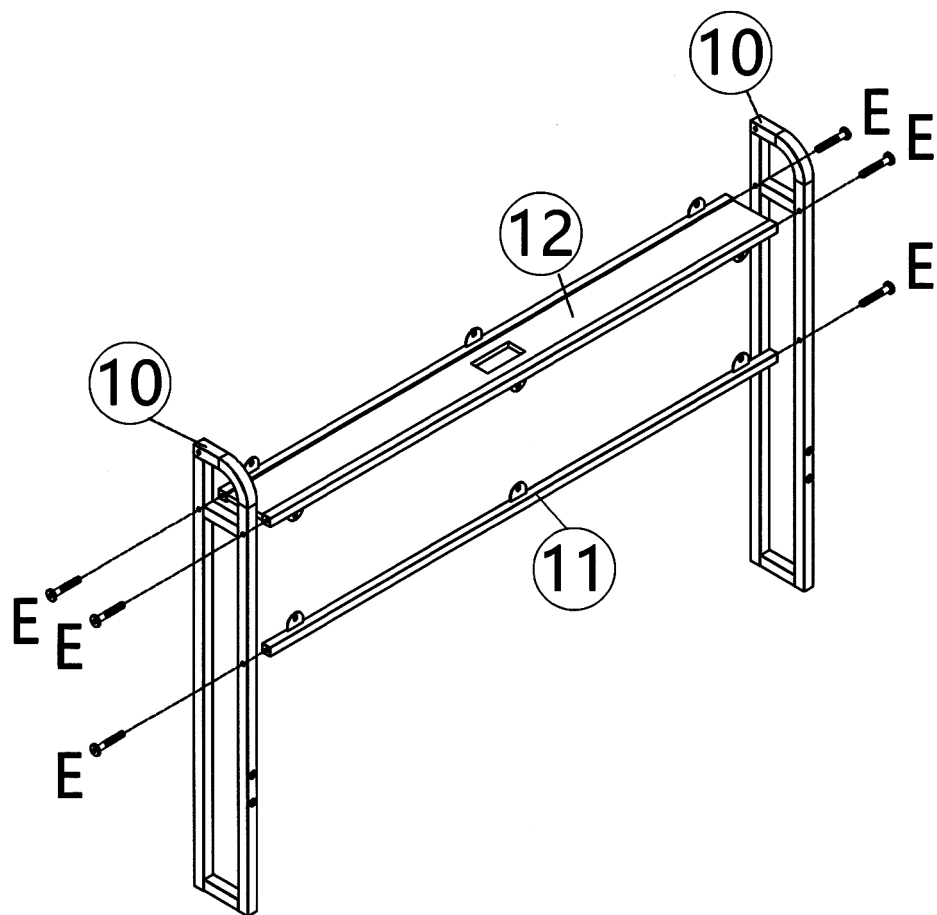

Step:2

 M6\*35 E X2PCS

 4# H X 1PC

 M6\*12 C X9PCS

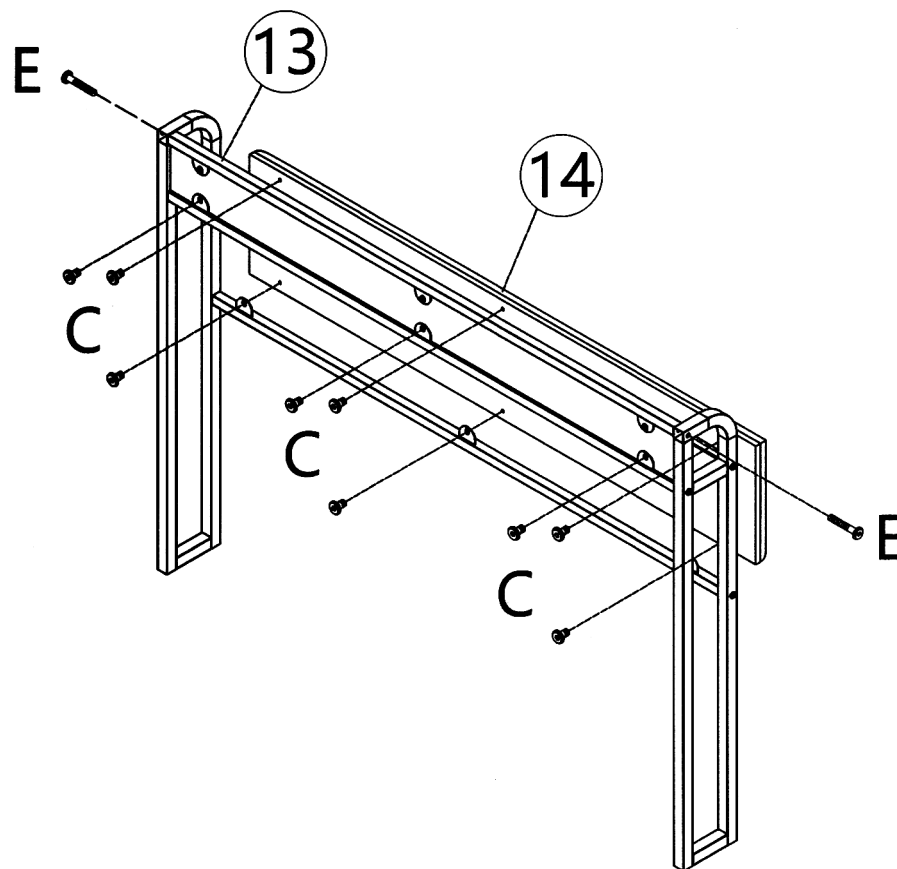

Step: 3

 M4\*15 **A** X2PCS

 4# **B** X 1PC

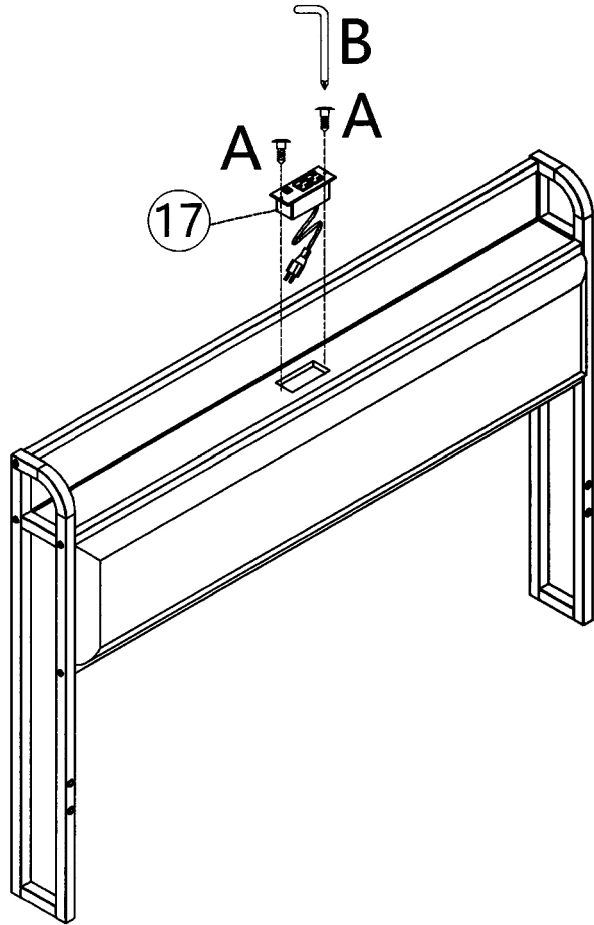

Step: 4

 M8\*45 **F** X2PCS

 4# **H** X 1PC

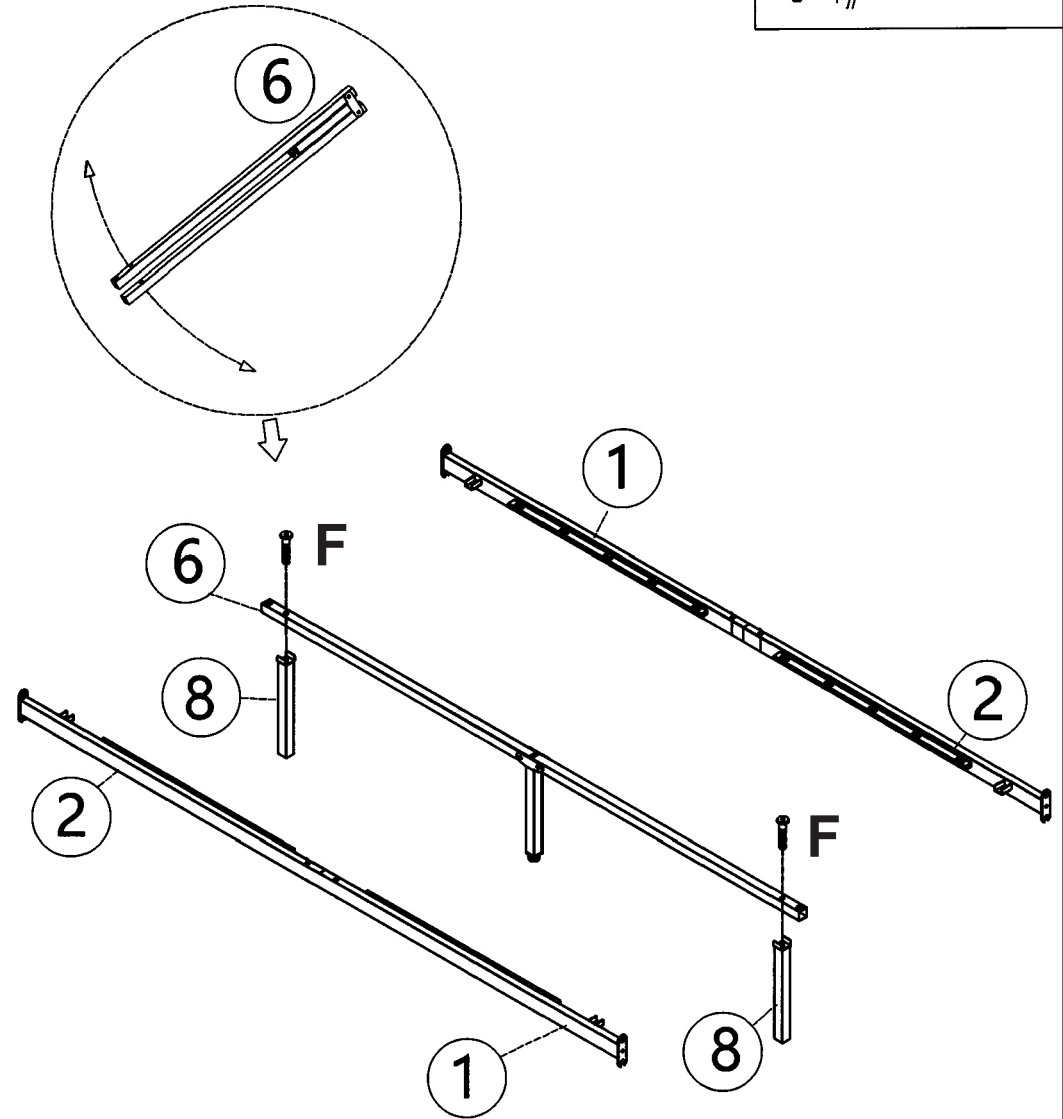

Step: 5

 **G** X2PCS  
M8\*16

 **F** X1PC  
M8\*45

 **D** X 6PCS  
M6\*25

 **4#** **K** X 1PC

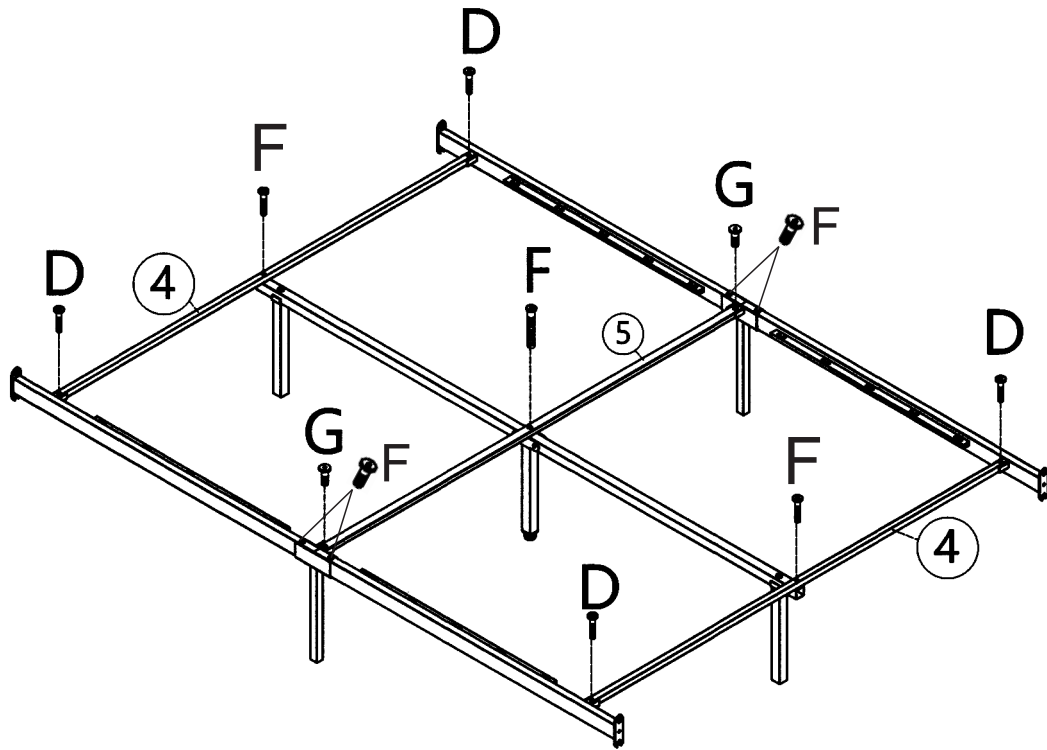

Step: 6

 **G** X8PCS  
M8\*16

 **H** X 1PC  
4#

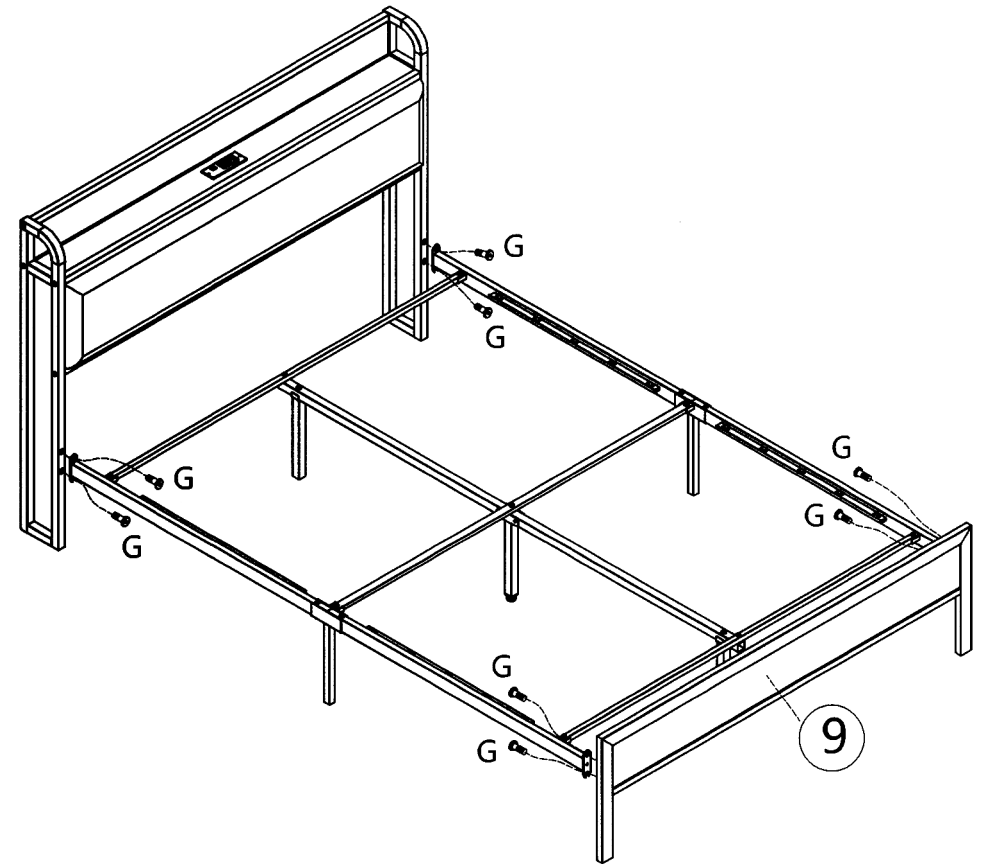

Step: 7

 15 20PCS

 4# HX 1PC

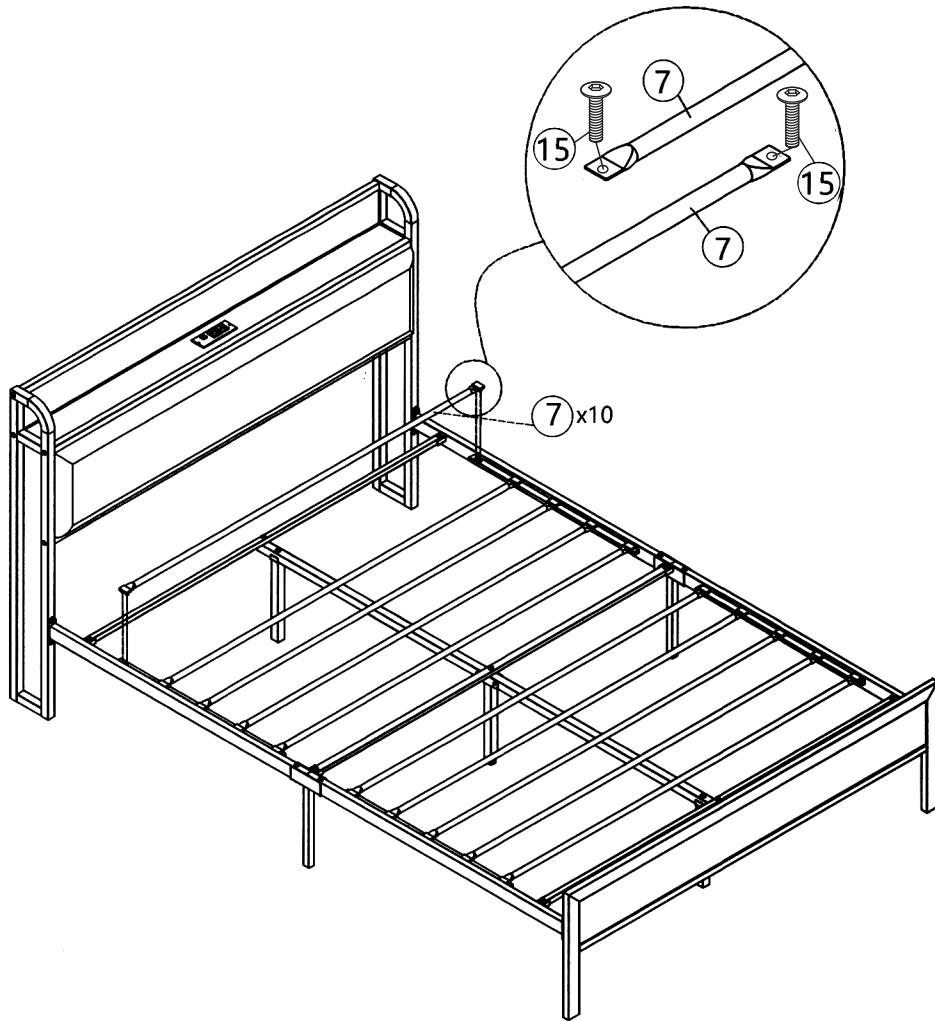

Note: Now you can tighten all the bolts

Step: 8

There is a small sealing pocket in the package.  
There are two pieces of double-sided adhesive tape  
and two crash pads in the sealing pocket.  
As shown in the figure below.

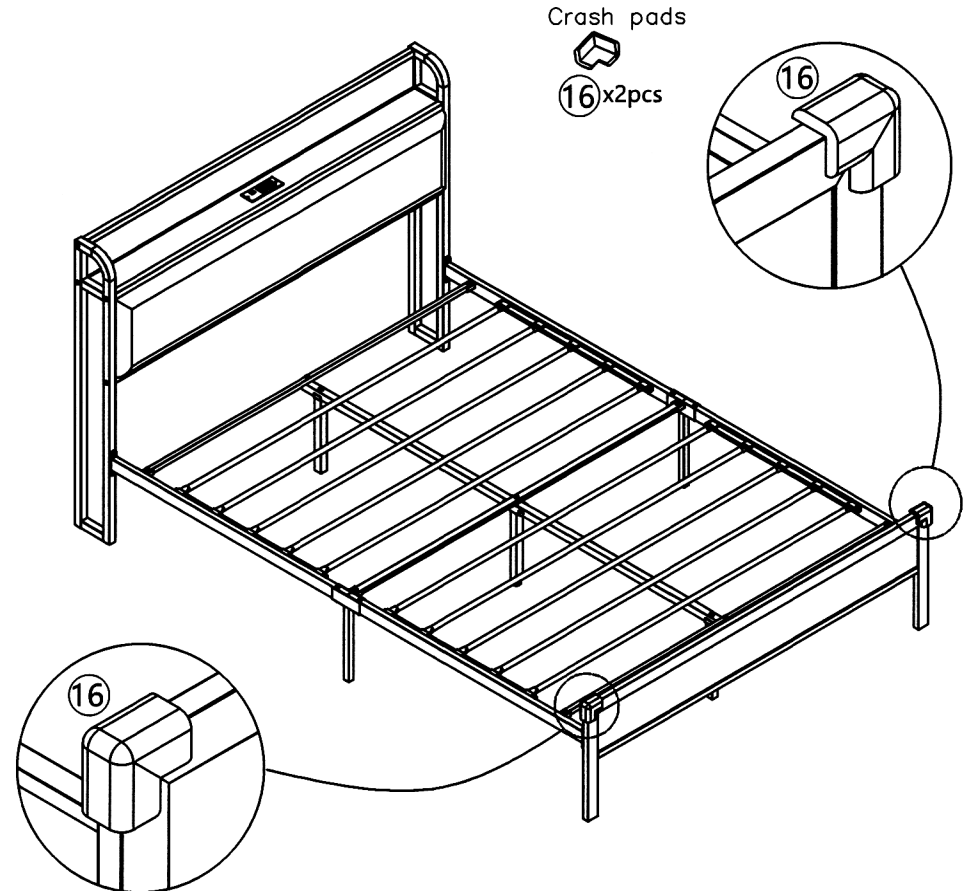

Please tear off  
the surface  
anti sticking  
sheet and stick  
the anti-collision  
cushion on it