

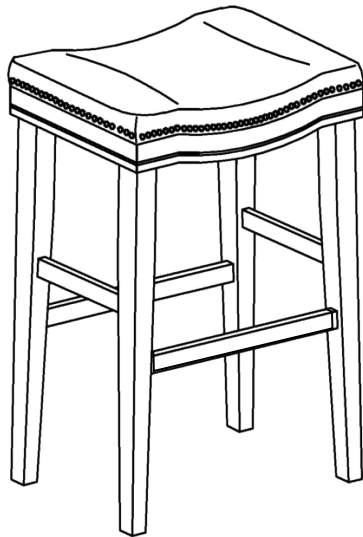



Assembly Instructions

Caution : You must read this before you proceed





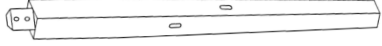

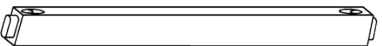
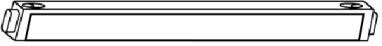
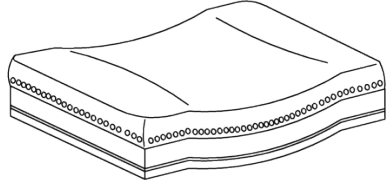
Bar Stool



Parts List

Label	Picture	Description	QTY
A		Leg (labbled A)	2
B		Leg (labbled B)	2
C		Upper Stretcher	2
D		Lower Stretcher	1
F		Lower Stretcher with metal kickplate	1
E		Cushion Seat	1





Hardware

Label	Picture	Description	QTY
①		Bolt	9
②		Spring Washer	9
③		Washer	9
④		Screw	9
⑤		Allen Key	1
⑥		Screwdriver	1

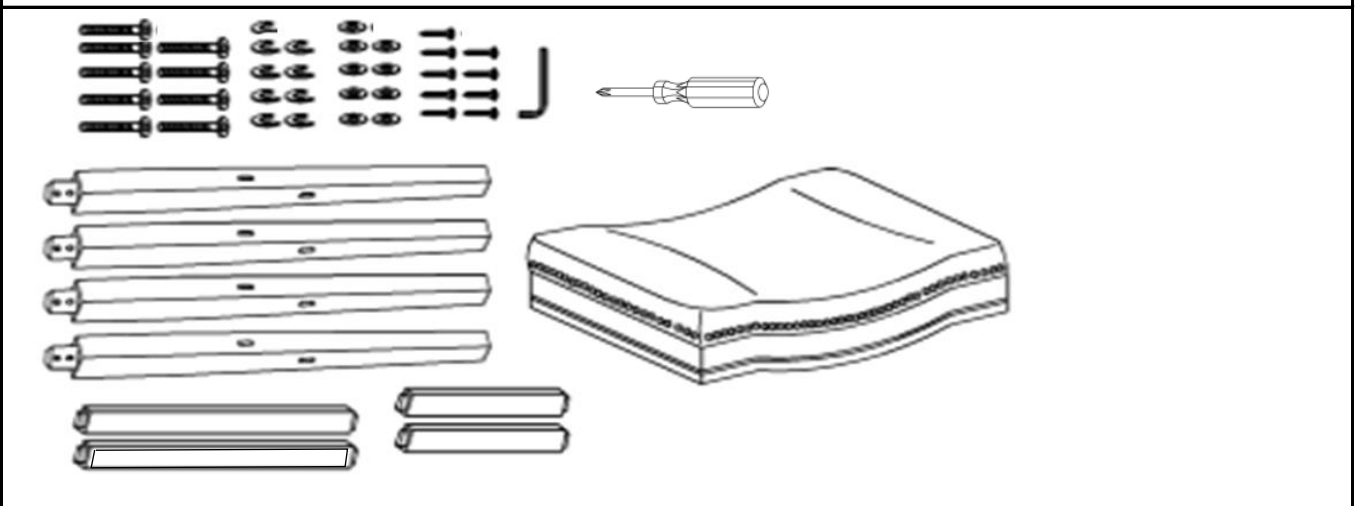
Assembly Preparation

Before Beginning Assembly:
Unpack and place all parts for clear visibility



-  • Read instructions, cover to cover-
-  • Have 2 adults on hand for assembly-
-  • Do not assemble on flooring or carpet-
-  • Assemble on a clean non-marring surface (packing foam)-
-  • Save all packaging until finished-

Assembly Steps

Overview

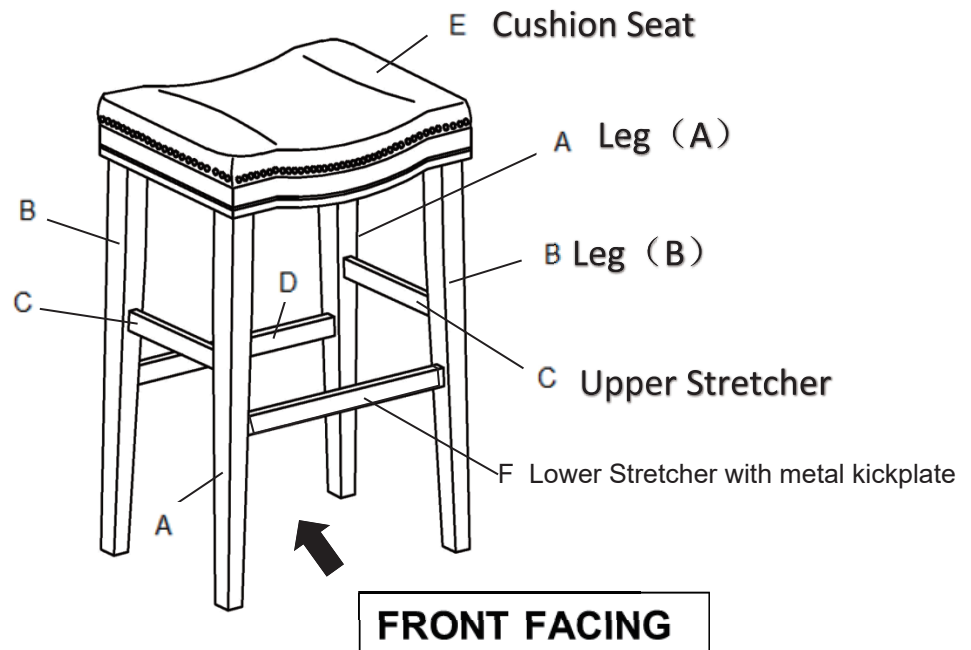

This Bar Stool has multiple parts and may require up to 30 minutes to assemble. To give you an overview of the Bar Stool parts, the above picture is to help you put the various parts into perspective. Please read through the instructions below to familiarise yourself with the parts and steps before assembly.

Step 1

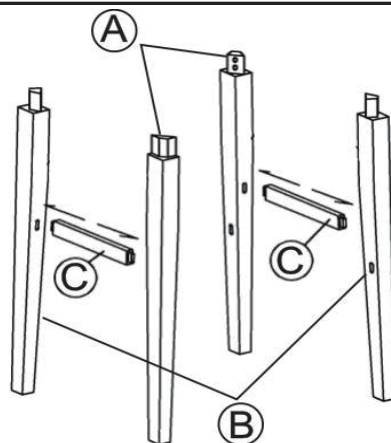

Place all the parts onto a clean, non-marring surface.
Insert a Upper Stretcher(C) between the Leg(A) and Leg(B) as pictured.
Repeat the same process with another Upper Stretcher(C) and the other pair of Leg(A) and Leg(B).

Ensure that the mounting positions on Stretchers(C) are facing downwards; and the mounting positions on the Legs(A&B) all face inwards.

Step 2

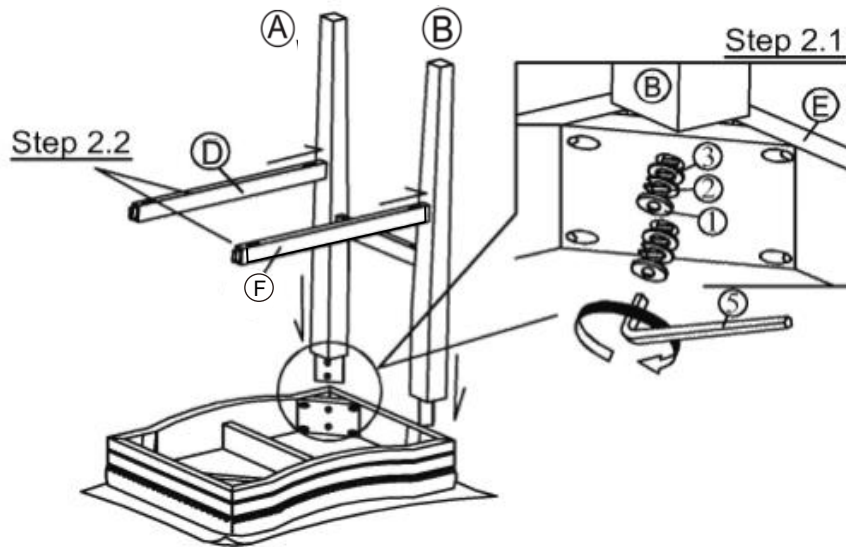

Place the Cushion Seat(E) facedown onto a clean, non-marring surface and carefully remove the Seat Cover.

2.1) Insert the first pair of Leg Frame(A&B&C) into the Cushion Seat(E). Attach Leg Frame(A&B&C) to the Cushion Seat(E) using Bolts(①), Spring Washers(②), and Washers(③) with Allen Key(⑤) as shown above.

Do not fully tighten the Bolts.

2.2) Insert the Lower Stretchers(D) & Lower Stretcher with metal kickplate (F) into the Leg(A) and Leg(B) as pictured.

Step 3

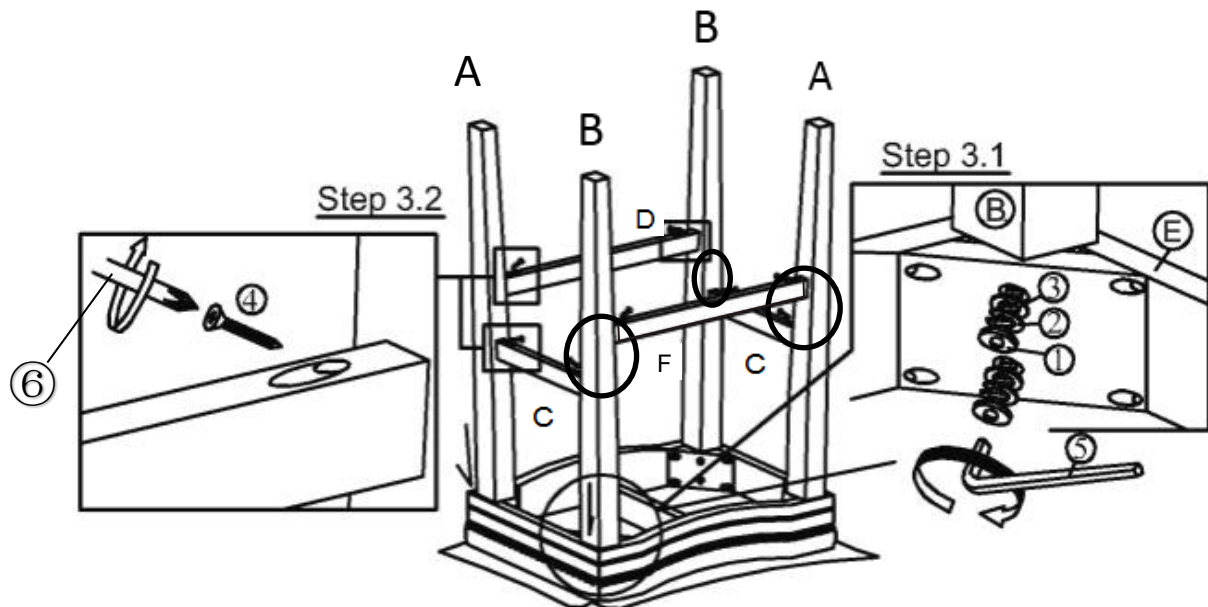

3.1) Insert the other pair of Leg Frame(A&B) into the Stretchers(C) and Cushion Seat(E).

Then attach using Bolts(①), Spring Washers(②), and Washers(③) with Allen Key(⑤) as shown above.

Do not fully tighten the Bolts.

3.2) Attach Stretchers(C&D&F) to Legs(A&B) using the Screws(④) with Screwdriver(⑥) as shown above.

Do not fully tighten the Screws.

Step 4

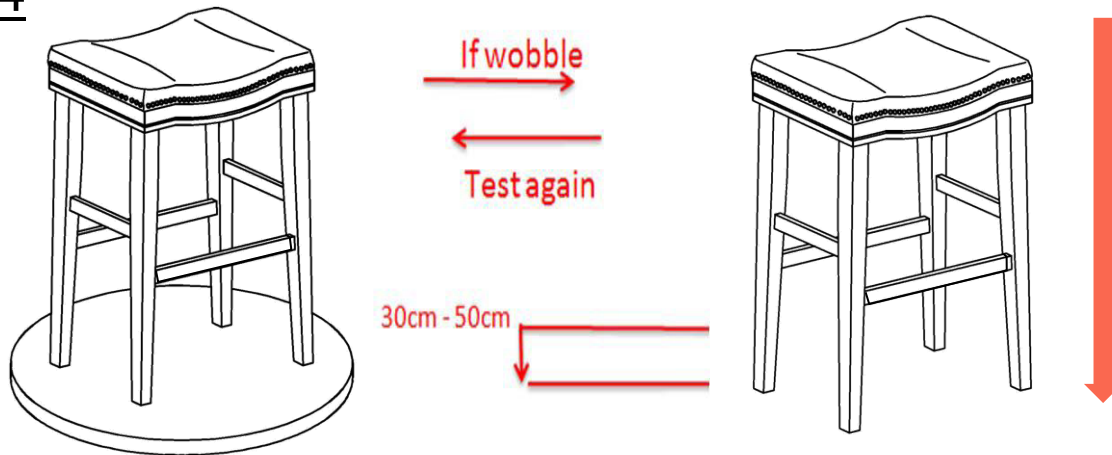

Place the Bar Stool on a **LEVEL SURFACE** to see if it wobbles.

If it wobbles, lift the Bar Stool some 30cm to 50cm high from the ground.

Keep your feet and toes well away from the drop zone.

Drop the Bar Stool freely and vertically with the four legs, hitting the ground, at the same time.

This Drop Test will help to ensure that all the Bolts, Screws, and gaps reach full alignment status.

Test again for evenness on a **LEVEL SURFACE**.

If no wobbles found, proceed to tighten all Bolts and Screws.











When tightening these Bolts and Screws, tighten sequentially.

DO NOT tighten any Bolt or Screw, fully and then move on towards the next one.

This could cause the frame to warp.

If there is still wobbles, loosen the Bolts and Screws and execute this same drop test.

If the Bar Stool is not Stable it could lead to damage to the product.

Care & Maintenance	
	• Furniture may scratch floors. We recommend using furniture pads to protect your floors.
	• Do not put hot items directly on furniture surface.
	• Do not clean furniture with harsh cleansers or polish.
	• Do not place furniture under direct sunlight.
	• Do not place furniture near heating or cooling vents.
	• Do not write on furniture without a padded barrier to protect the surface.
	• Do not place furniture outside . For indoor use only.
	• Not for commercial use. For residential use only.
	• Stains may be removed with mild soap solution and damp cloth.
	• Children should not climb or jump on the furniture.
	• Dust and pick-up spills using a clean, non-colored, lint-free cloth.

Questions & Answers about Proposition 65

- What is Proposition 65?

Proposition 65 requires businesses to provide warnings to Californians about significant exposures to chemicals that cause cancer, birth defects or other reproductive harm. These chemicals can be in the products that Californians purchase, in their homes or workplaces, or that are released into the environment. By requiring that this information be provided, Proposition 65 enables Californians to make informed decisions about their exposures to these chemicals.

Proposition 65 also prohibits California businesses from knowingly discharging significant amounts of listed chemicals into sources of drinking water.

Proposition 65 requires California to publish a list of chemicals known to cause cancer, birth defects or other reproductive harm. This list, which must be updated at least once a year, has grown to include approximately 900 chemicals since it was first published in 1987.

- What types of chemicals are on the Proposition 65 list?

The list contains a wide range of naturally occurring and synthetic chemicals that include additives or ingredients in pesticides, common household products, food, drugs, dyes, or solvents. Listed chemicals may also be used in manufacturing and construction, or they may be byproducts of chemical processes, such as motor vehicle exhaust.

- What does a warning mean?

If a warning is placed on a product label or posted or distributed at a workplace, a business, or in rental housing, the business issuing the warning is aware or believes that it is exposing individuals to one or more listed chemicals.

By law, a warning must be given for listed chemicals unless the exposure is low enough to pose no significant risk of cancer or is significantly below levels observed to cause birth defects or other reproductive harm.

- Where can I get more information on Proposition 65?

If you have specific questions on the administration or implementation of Proposition 65, you can contact OEHHA's Proposition 65 program at P65.Questions@oehha.ca.gov, or by phone at (916) 445-6900.