

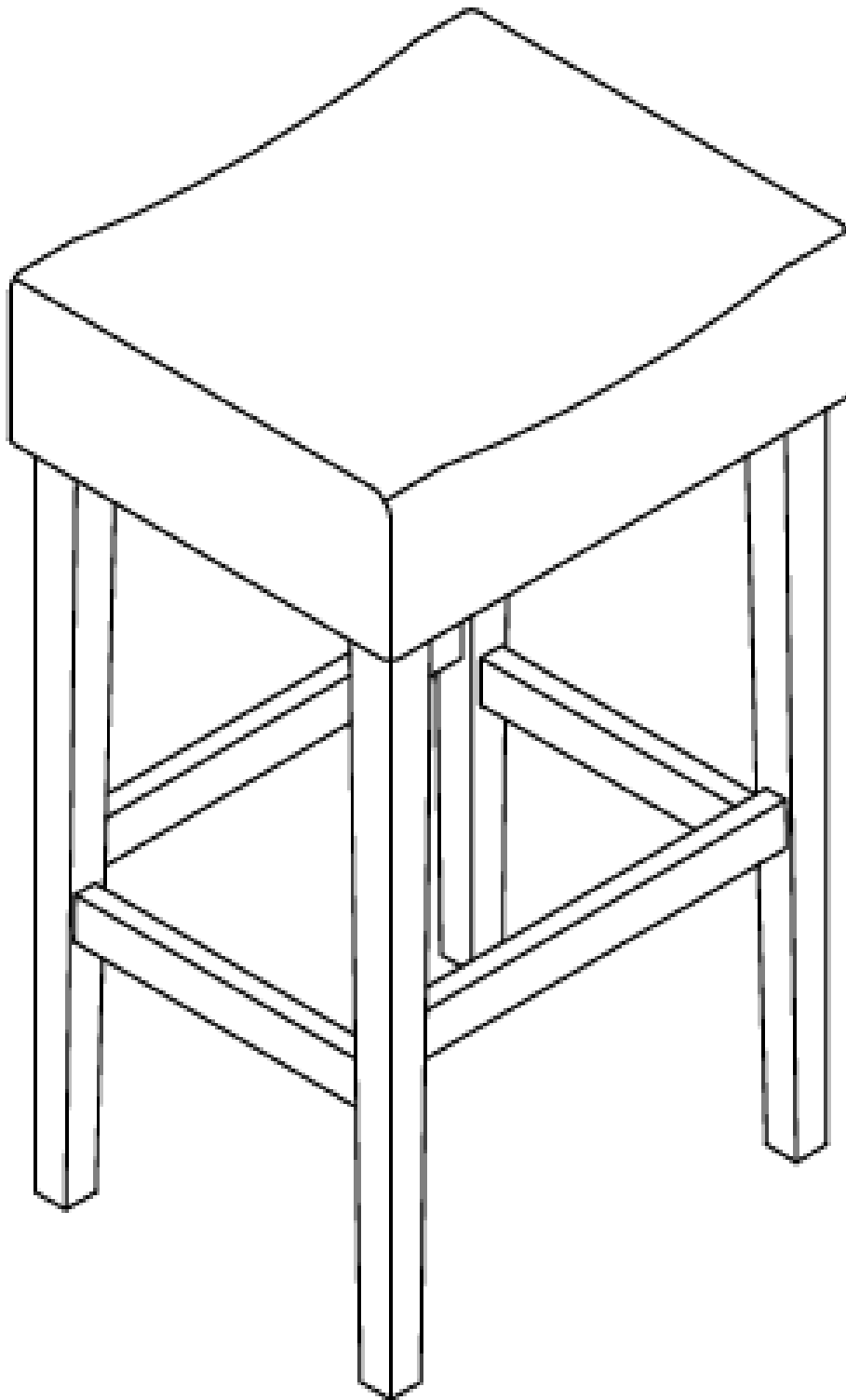

Assembly Instructions

Caution : You must read this before you proceed.





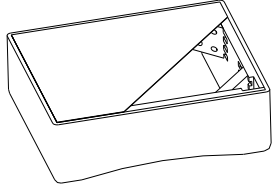
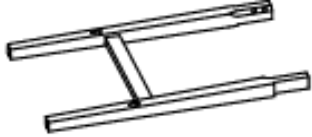

Bar / Counter Stool



Parts List

Part NO.	Picture	Description	QTY
A		Seat	1 PC
B		'H' Leg Frame	2 PCS
C		Side Rails	2 PCS

Hardware

Label	Picture	Description	QTY
1		M6 x 50mm Bolt	9 PCS
2		Spring Washer Ring	9 PCS
3		Flat Washer Ring	9 PCS
4		Allen Key	1 PC
5		Screw (M4*38mm)	5 PCS
6		Screwdriver	Not provided

Assembly Preparation

Before Beginning Assembly:

Unpack and place all parts for clear visibility

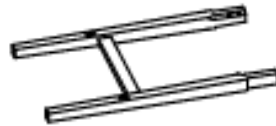

Pack A for assembling the 'H' Leg Frame (B) to the Chair Seat (A)

9pcs of 50mm Bolts + 9pcs of Flat Washer Ring + 9pcs of Spring Washer + one Allen Key

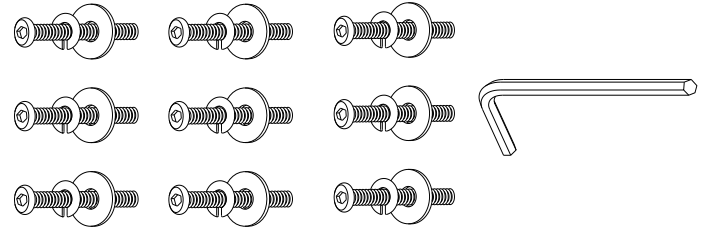

Pack B for assembling the Side Rails (C) to the 'H' Leg Frame (B)

5pcs Ø4*38mm Screws



- Read instructions, cover to cover-



- Have 2 adults on hand for assembly-



- Do not assemble on flooring or carpet-



- Assemble on a clean non-marring surface(packing foam)-



- Save all packaging until finished-

Assembly Steps

Step 1



A. Seat

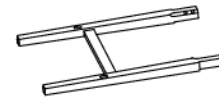

B. 'H' Leg Frame



C. Side Rails

Place the Barstool Seat (A) onto a soft surface to avoid any scratches or damages to the product.

REMOVE the Seat Base Cover from the underside of the Seat (A), take out the Side Rails (C) and hardware.

Step 2

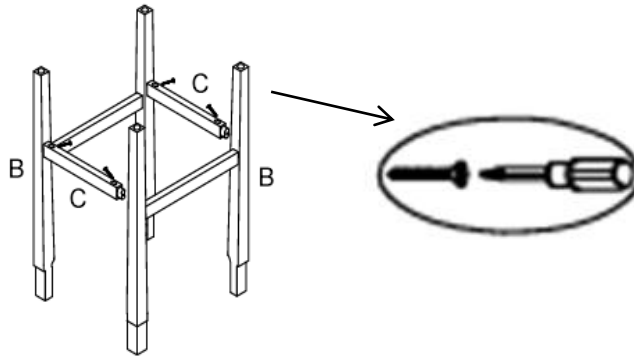

Insert the Side Rail (C) into the oval housing of 'H' leg frame (B) as shown above.

Then, use the hardware of Part B to attach the Side Rails (C) to the other 'H' Leg frame (B).

WARNING !! DO NOT OVER TIGHTEN. OVER TIGHTENING COULD LEAD TO DAMAGE OF THE PRODUCT. TIGHTEN ONLY UNTIL SECURE.

Step 3

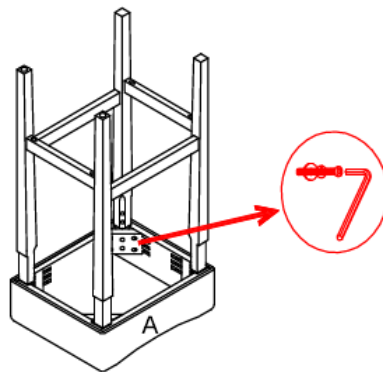

Place the Seat (A) onto a soft and clean surface to avoid any scratches or damages to the product.

Attach the assembled unit from Step 2 to the Chair Seat (A).

Use the hardware of Part A to connect these.

WARNING!! DO NOT OVER TIGHTEN. OVER TIGHTENING COULD LEAD TO DAMAGE OF THE PRODUCT. TIGHTEN ONLY UNTIL SECURE

Step 4

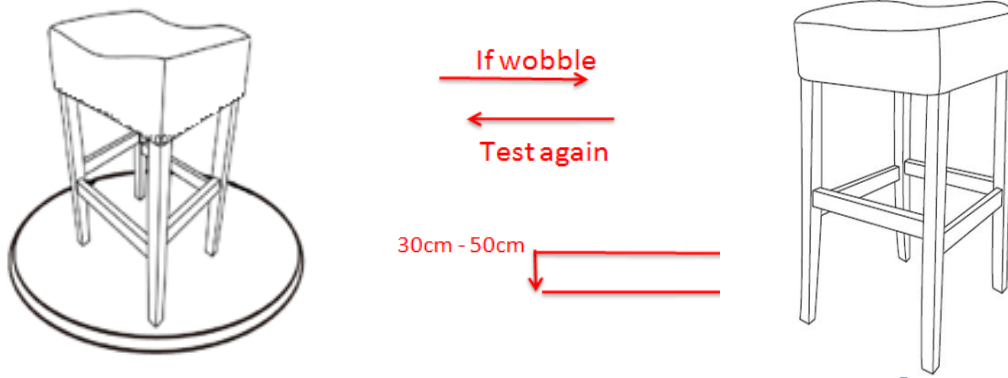

Place the chair on a **LEVEL SURFACE** to see if it wobbles.

If it wobbles, lift the chair to some 30cm to 50cm height from the ground.

Keep your feet and toes well away from the drop zone.

Drop the chair freely and vertically with the four legs, hitting the ground at the same time.

This Drop Test will help to ensure that all the bolts and gaps, to all reach full alignment status.

Test again for evenness on a **LEVEL SURFACE**.

If no wobbles found, proceed to tighten all the bolts.

CAUTION : When tightening these bolts, tighten sequentially.

DO NOT tighten any screw fully and then towards the next one.

This would cause the frame to warp.

If there is still wobbles, loosen the bolts and execute this same drop tests.

WARNING!! IF CHAIR IS NOT STABLE , IT COULD LEAD TO DAMAGING THE PRODUCT.

Step 5

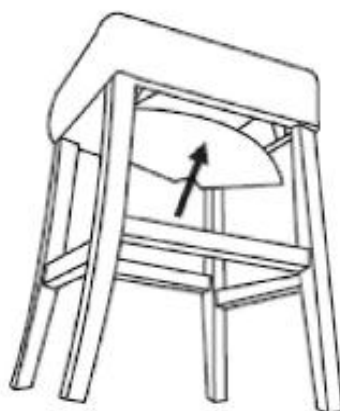

Place the Seat Base Cover Back underneath the Chair Seat (as shown in picture) from where it was originally removed from.

Smooth down the 4 velcro edges with your hand.

The bar/ counter stool is now ready for use.

Care & Maintenance



- Do not put hot items directly on furniture surface.



- Do not clean furniture with harsh cleansers or polish.



- Do not place furniture under direct sunlight.



- Do not place furniture near heating or cooling vents.



- Do not write on furniture without a padded barrier to protect the surface.



- Do not place furniture outside. For indoor use only.



- Not for commercial use. For residential use only.



- Stains may be removed with mild soap solution and damp cloth.



- Dust and pick-up spills using a clean, non-colored, lint-free cloth.