

Assembly Instructions

Caution : You must read this before you proceed

Care & Maintenance



- Not for commercial use. For residential use only.



- Furniture may scratch floors. We recommend using furniture pads to protect your floors.



- Do not put hot items directly on furniture surface.



- Do not clean furniture with harsh cleansers or polish.



- Do not place furniture under direct sunlight.



- Do not place furniture near heating or cooling vents.



- Do not write on furniture without a padded barrier to protect the surface.



- Do not place furniture outside . For indoor use only.



- Stains may be removed with mild soap solution and damp cloth.



- Children should not climb or jump on the furniture.





- Dust and pick-up spills using a clean, non-colored, lint-free cloth.

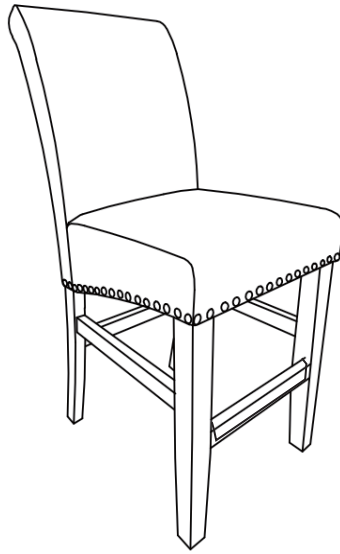

Bar/Counter Chair

Please look in the inner box for hardware packs and legs.
Sets often ship in multiple boxes and may arrive a day or two apart

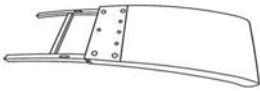
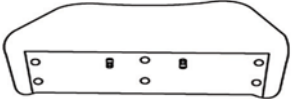

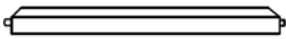

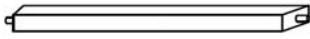



Parts List

Part NO.	Picture	Description	QTY
A		Chair Back	1
B		Chair Seat	1
C		Left Front Leg	1
D		Right Front Leg	1
E		Left Side Rail	1











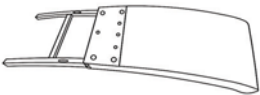



F		Right Side Rail	1
G		Front Rail	1
H		Seat Base Cover	1

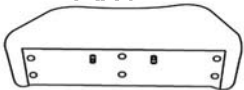



Hardware

Label	Picture	Description	QTY
①		75mm Long Bolt	5
②		50mm Long Bolt	7
③		Flat Washer Ring	11
④		Spring Washer Ring	11
⑤		Allen Wrench	1
⑥		50mm Screw	7
⑦		Screwdriver	1

Assembly Preparation

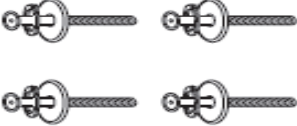
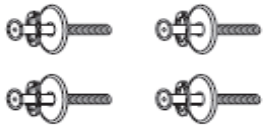
Before Beginning Assembly:

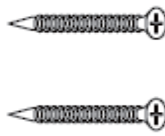
<p>Pack A: for assembling Chair Seat(B), place Chair Seat(B) horizontally, insert two(2) dowels, in central point of Chair Back(A)</p>	<p>50mm Long Bolt: 2 Flat Washer Ring: 2 Spring Washer: 2 Allen Wrench: 1</p>	
<p>Pack B: for assembling the Chair Seat(B) to the hind legs of Chair Back(A)</p>	<p>75mm Long Bolt: 4 Flat Washer Ring: 4 Spring Washer: 4</p>	
<p>Pack C: for assembling the Chair Seat(B) to the Front Leg Frame(C)</p>	<p>50mm Long Bolt: 4 Flat Washer Ring: 4 Spring Washer: 4</p>	
<p>Pack D for assembling the Left Side Rails(E) & Right Side Rails(F) to the Left Front Leg (C) & Right Front Leg (D)</p>	<p>50mm Screw: 2</p>	
<p>Pack E for assembling the Left Side Rails(E) & Right Side Rails(F) to the Chair Back (A)</p>	<p>50mm Screw: 2</p>	
<p>Pack E for assembling the Front Rail(G) to the Front Leg</p>	<p>50mm Screw: 2</p>	



- Read instructions



- Assemble on a clean non-marring surface

Assembly Steps

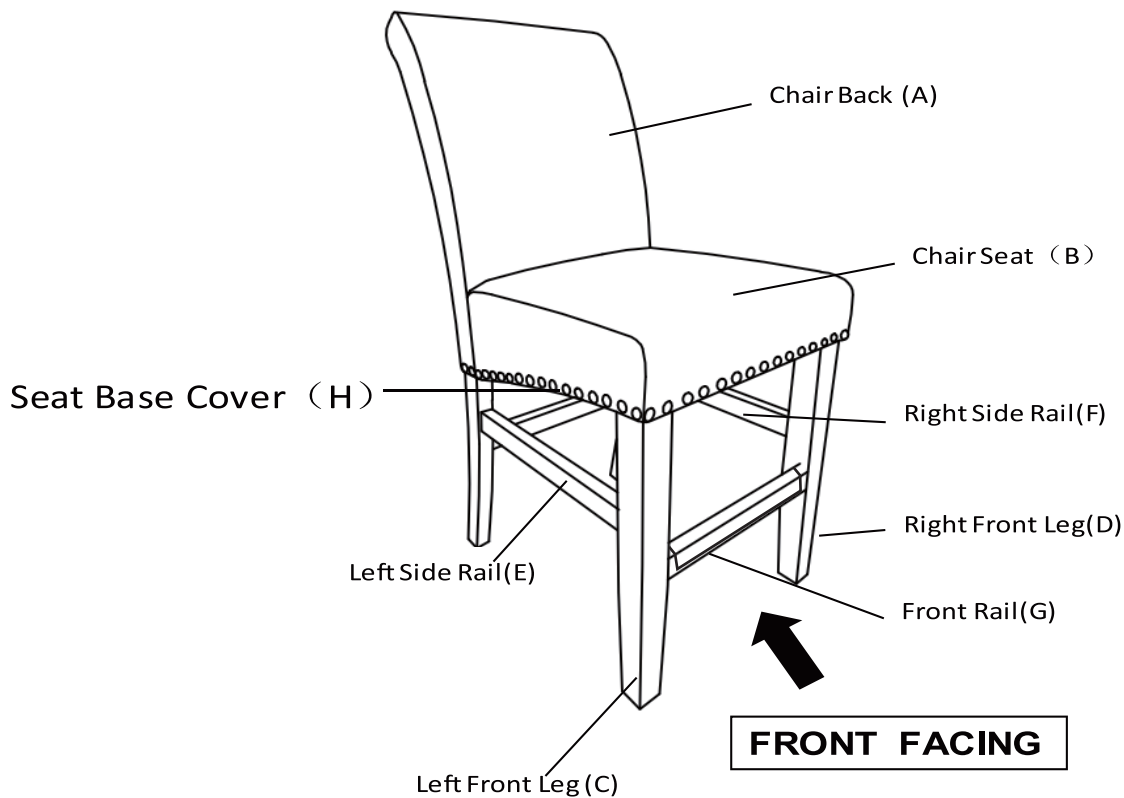

This Bar/Counter Chair has multiple parts and may require up to 30 minutes to assemble. To give you an overview of the bar/counter chair's parts, the above picture is to help you put the various parts into perspective. Please read through the instructions herebelow to familiarise yourself with the parts and steps before assembly.

Step 1

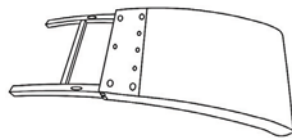

A.Chair Back



B.Chair Seat & H.Seat Base Cover

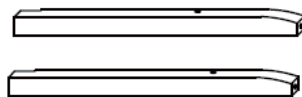

C. Front Left Leg & D. Front Right Leg

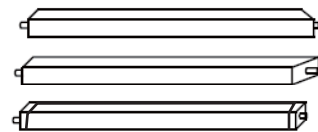

E. Left Side Rail & F. Right Side Rail & G. Front Rail

Place the Chair Back(A) and Chair Seat (B) on a soft surface to avoid any scratches or damage to the product.

REMOVE the Seat Base Cover(H) from the underside of the Chair Seat(B), pull out the Side Rails (D) and hardware.

Step 2

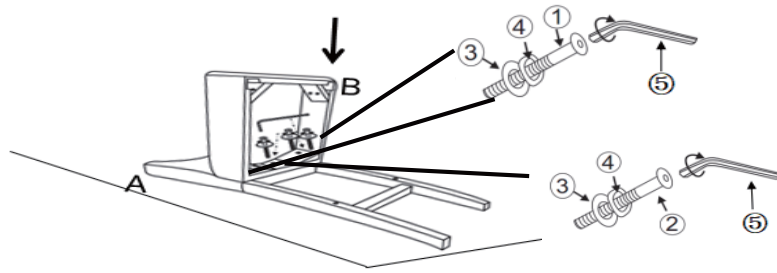

Place the Chair Back(A) onto a flat surface.

Insert the dowels on Chair Seat(B) into the mounting position in Chair Back(A).

Align the mounting position from Chair Back(A) with the mounting position of Chair Seat(B).

Push the seat frame down as seen in picture 1.

This action helps to ensure the Chair Seat(B) is pressed into the Chair Back(A) with no gap in between .

When complete, lock the middle mounting point with 2 Bolt②, 2 Spring Washer④ and 2 Flat Washer③ with Allen Wrench⑤ and the corner mounting points with 2 Bolt①, 2 Spring Washer④ and 2 Flat Washer③ with Allen Wrench⑤.

WARNING!! DO NOT OVER TIGHTEN. OVER TIGHTENING COULD LEAD TO DAMAGE PRODUCT.

Step 3

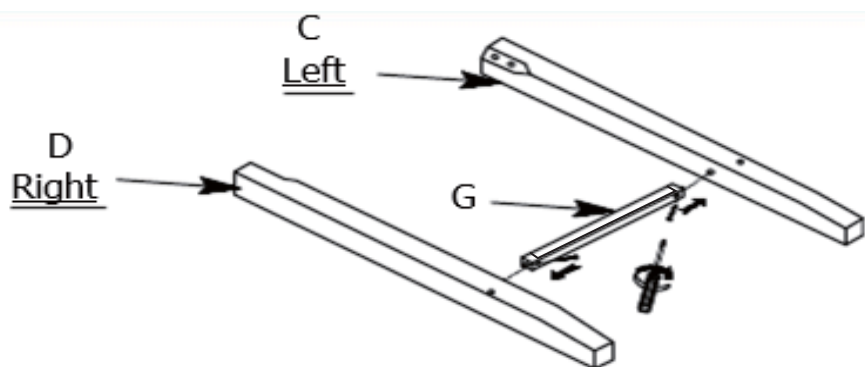

Insert the Front Rail(G) into the oval housing of Left Front Leg (C) & Right Front Leg (D) as shown above.

Then, use Hardware to attach the Front Rail(G) to the Left Front Leg (C) & Right Front Leg (D).

At this stage, LOOSELY FASTEN these bolts

Step 4

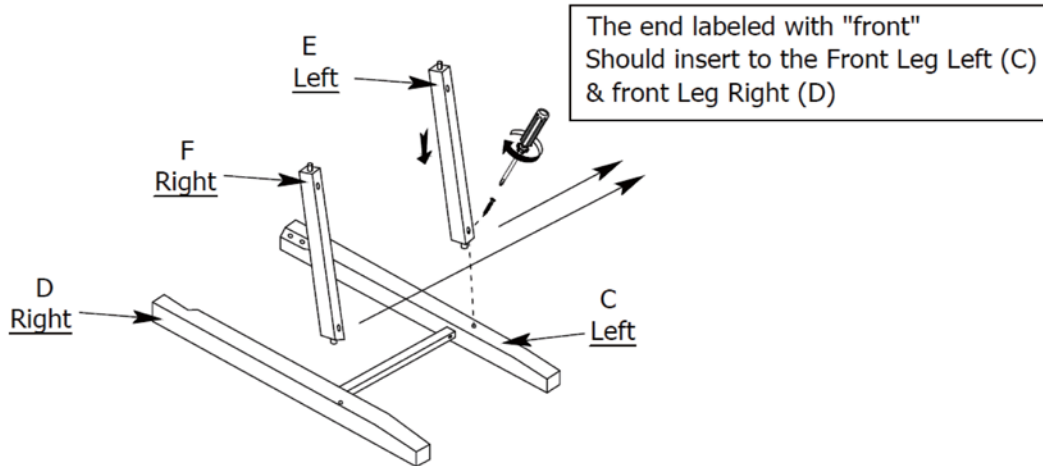

Insert the Left Side Rail(E) into the oval housing of Left Front Leg(C),use Hardware to attach the the Left Side Rail(E) to the Left Front Leg (C); Insert the Right Side Rail(F) into the oval housing of Right Front Leg(D) Then, use Hardware to attach the Right Side Rail(F) to Right Front Leg (D).

At this stage, LOOSELY FASTEN these bolts

Step 5

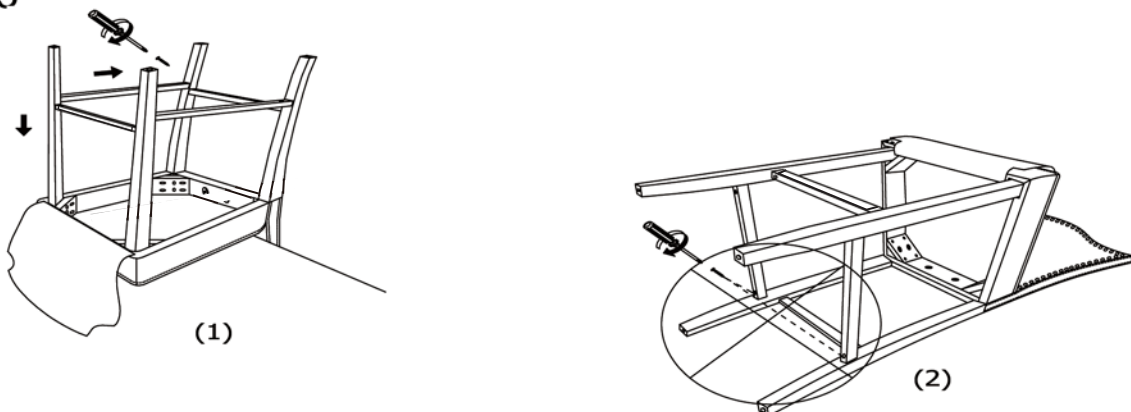

Next, place the chair onto the side of a table as seen in Picture 1. You will now have the chair bottom and legs facing skywards. Insert the assembled unit from Step 3 into the Chair Seat (B). **WARNING!! DO NOT POSITION THE FRONT LEG AS SHOWN IN PICTURE 2 .**

THIS PICTURE SHOWS THE CHAIR BACK STAYS AGAINST THE GROUND and THE LEGS HORIZONTAL IN MIDAIR.

Then use Hardware to attach the Side Rails with the Front and Hind Legs. At this stage, LOOSELY FASTEN these bolts

Step 6

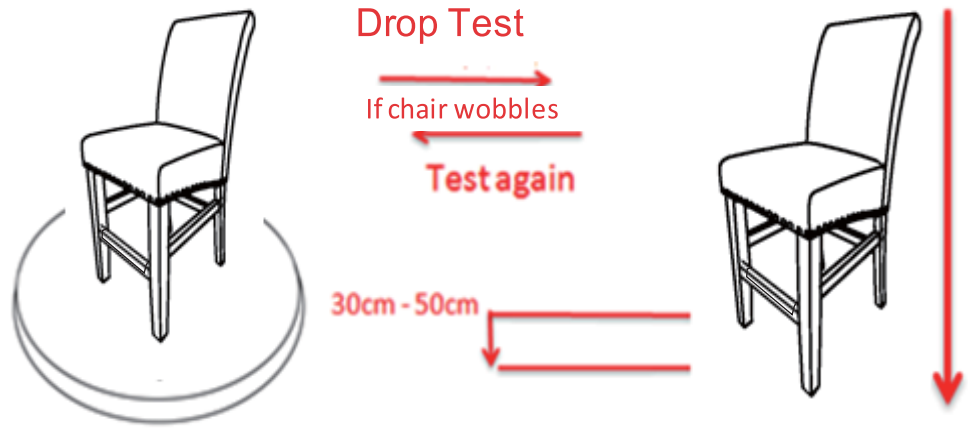

Place the chair on a LEVEL SURFACE.

If uneven, lift the chair to some 30cm to 50cm height from the ground.

Keep your feet and toes well away from the drop zone.

Drop the chair freely and vertically with the four legs, hitting the ground, at the same time.

This Drop Test will help to ensure all bolts and gaps reach full alignment status.

Test again for evenness on a LEVEL SURFACE.

If balanced, **tighten all bolts.**

CAUTION : When tightening these bolts, tighten in sequence.

Not doing so would cause the frame to warp.

If chair is still uneven, loosen the bolts and execute this same drop test.

Step 7

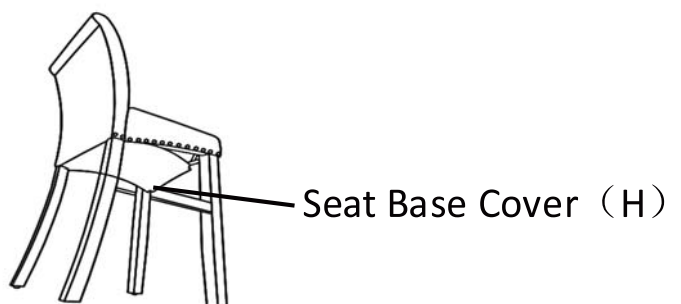

Place the Seat Base Cover(H) underneath the chair seat (as shown in picture) where it was removed from originally.

Press down on the velcro tape on all 4 sides at the edge of the seat box.

Turn the chair upright, it is now ready for use.

Questions & Answers about Proposition 65

- What is Proposition 65?

Proposition 65 requires businesses to provide warnings to Californians about significant exposures to chemicals that cause cancer, birth defects or other reproductive harm. These chemicals can be in the products that Californians purchase, in their homes or workplaces, or that are released into the environment. By requiring that this information be provided, Proposition 65 enables Californians to make informed decisions about their exposures to these chemicals.

Proposition 65 also prohibits California businesses from knowingly discharging significant amounts of listed chemicals into sources of drinking water.

Proposition 65 requires California to publish a list of chemicals known to cause cancer, birth defects or other reproductive harm. This list, which must be updated at least once a year, has grown to include approximately 900 chemicals since it was first published in 1987.

- What types of chemicals are on the Proposition 65 list?

The list contains a wide range of naturally occurring and synthetic chemicals that include additives or ingredients in pesticides, common household products, food, drugs, dyes, or solvents. Listed chemicals may also be used in manufacturing and construction, or they may be byproducts of chemical processes, such as motor vehicle exhaust.

- What does a warning mean?

If a warning is placed on a product label or posted or distributed at a workplace, a business, or in rental housing, the business issuing the warning is aware or believes that it is exposing individuals to one or more listed chemicals.

By law, a warning must be given for listed chemicals unless the exposure is low enough to pose no significant risk of cancer or is significantly below levels observed to cause birth defects or other reproductive harm.

- Where can I get more information on Proposition 65?

If you have specific questions on the administration or implementation of Proposition 65, you can contact OEHHA's Proposition 65 program at P65.Questions@oehha.ca.gov, or by phone at (916) 445-6900.