

Assembly Instructions

Caution: You must read this Assembly Instructions before you proceed

Please look in the Left Front Leg for hardware packs.

Bar Cart

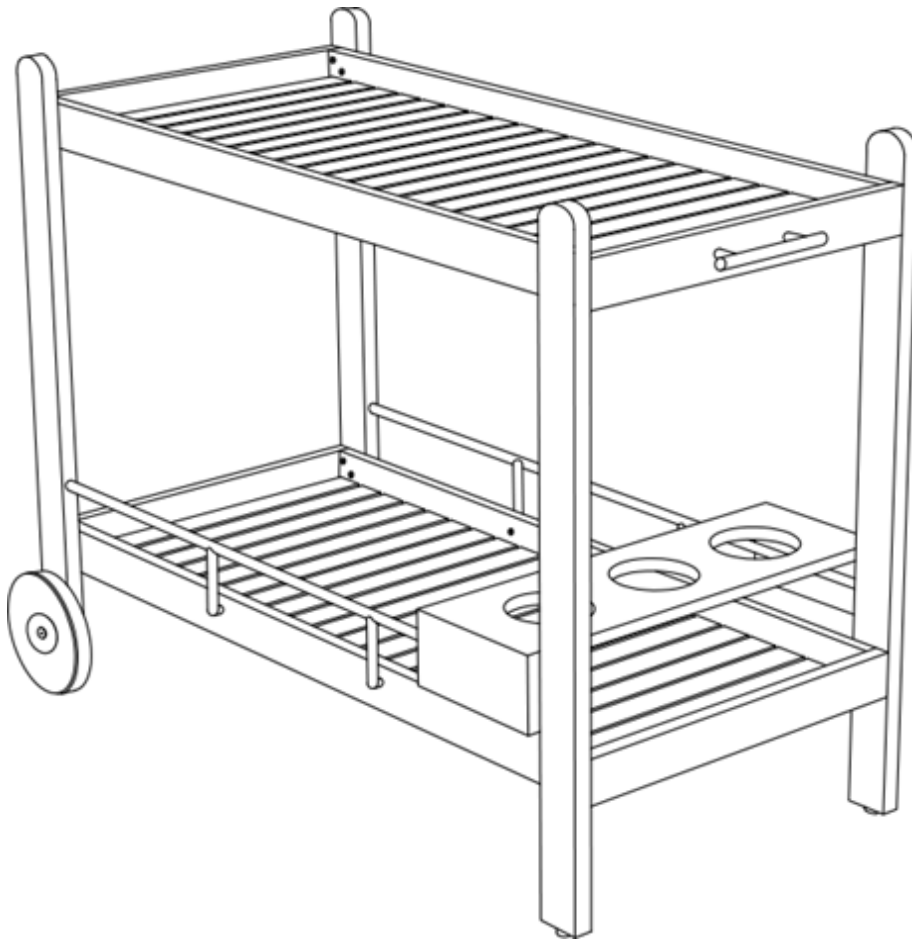







Caution: This Bar Cart is NOT a TOY.

Keep your child / children at bay in the process of assembly.





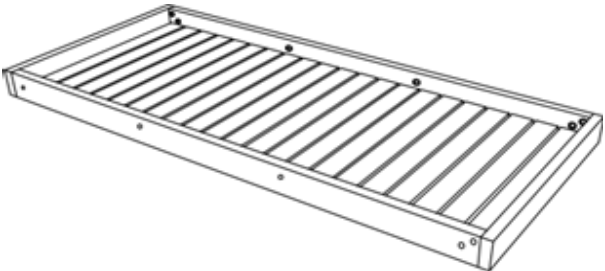
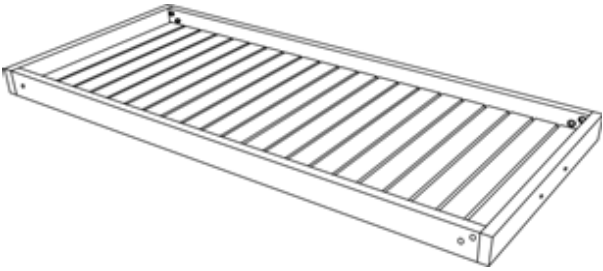
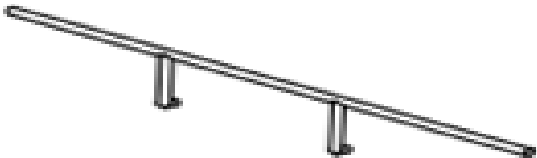

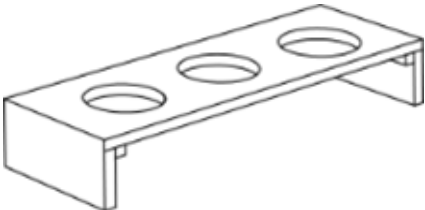

For turning/lifting the Bar Cart and to prevent damage to the Bar Cart, two adult persons may be needed to execute this action.

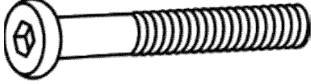
Parts List

Label	Picture	Description	QTY
A	 A vertical, tapered wooden leg with rounded ends. It features two pairs of small circular holes, one pair near the top and one pair near the bottom, positioned towards the inner edge.	Left Front Leg	1
B	 A vertical, tapered wooden leg with rounded ends. It features two pairs of small circular holes, one pair near the top and one pair near the bottom, positioned towards the outer edge.	Right Front Leg	1
C	 A vertical, tapered wooden leg with rounded ends. It features two pairs of small circular holes, one pair near the top and one pair near the bottom, positioned towards the inner edge. The bottom hole is slightly larger than the others.	Left Back Leg	1

D		Right Back Leg	1
E		Bottom Panel	1
F		Top Panel	1
G		Cross Bars	2
H		Handle	1
I		Wheels	2
J		Bottle Holder	1

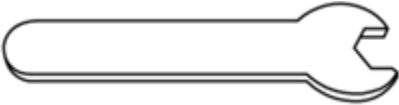
Hardware

Label	Picture	Description	QTY
①		Bolt (M8*70mm)	3
②		Bolt (M6*30mm)	23
③		Nut (M8)	3
④		Flat Washer (M8.5/20x2mm)	3
⑤		Flat Washer (M8.5/30x2mm)	3
⑥		Flat Washer (M8.5/30x5mm)	3
⑦		Iron Tube (M10/8.2x0.9mm)	3
⑧		Wrench	1
⑨		Allen Wrench	1

Assembly Preparation

Before Beginning Assembly:

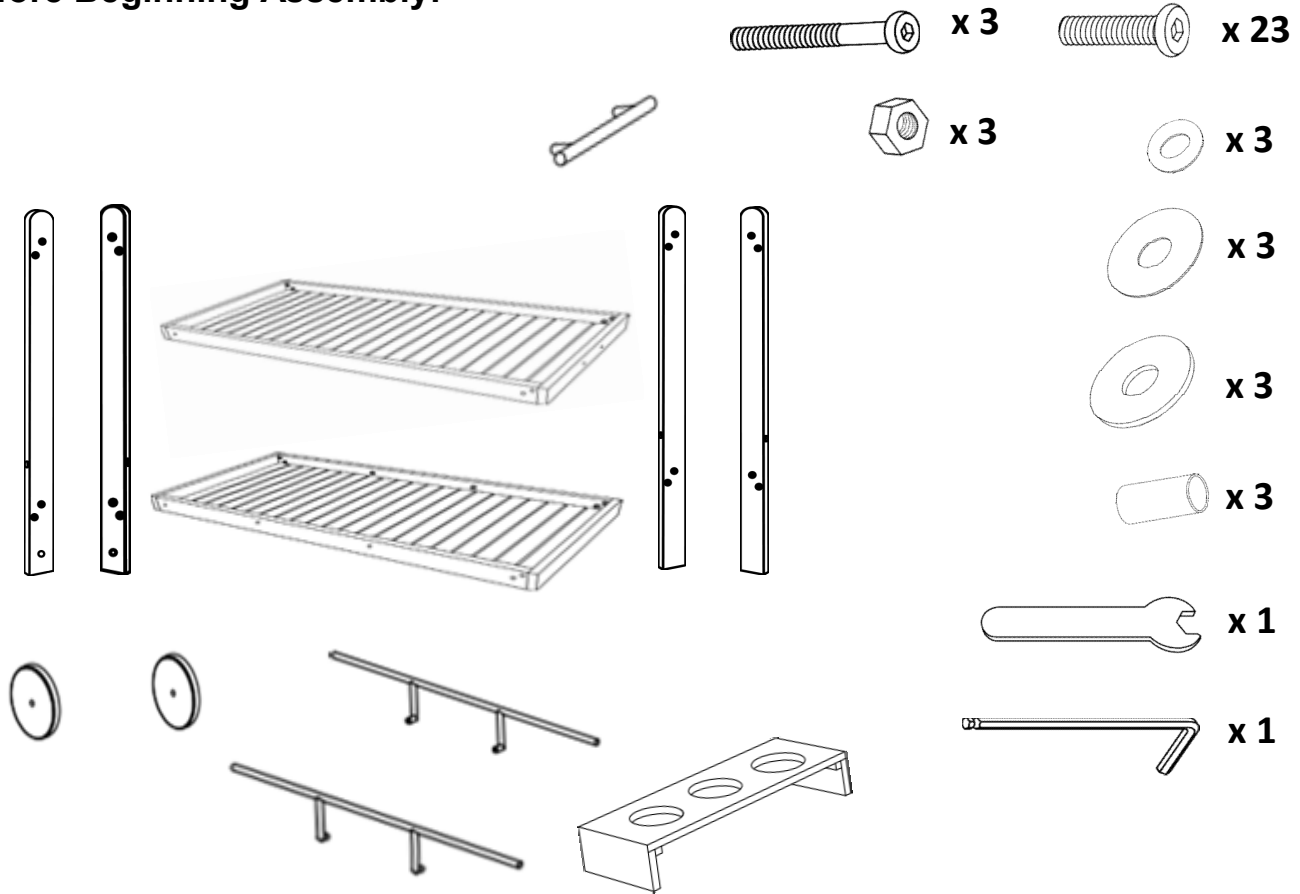

- Read instructions, cover to cover-



- Have 2 adults on hand for assembly-



- Do not assemble on flooring or carpet-



- Assemble on a clean non-marring surface (packing foam)-



- Save all packaging until finished-

Assembly Steps

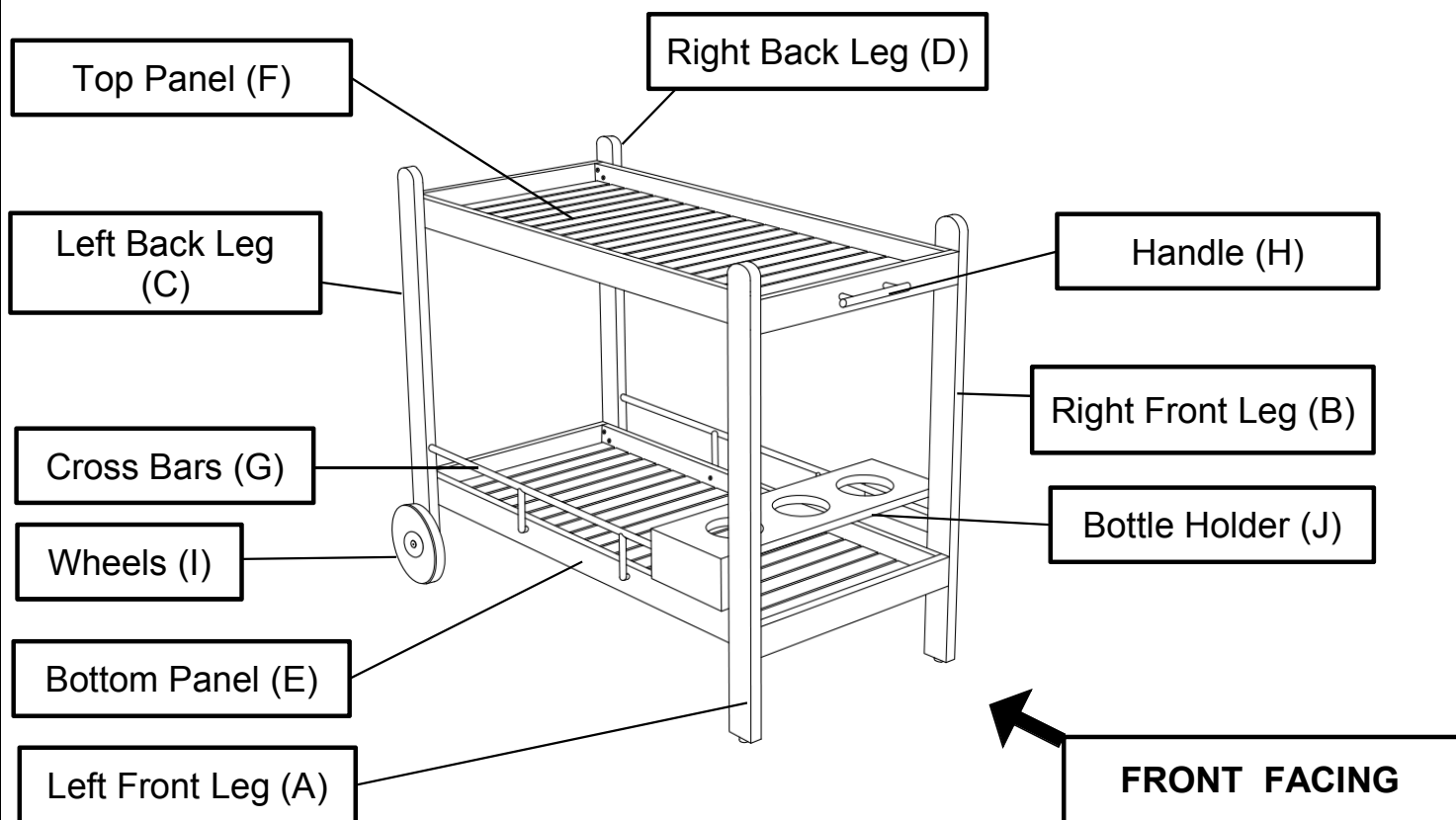

This Bar Cart has multiple parts and may require up to 30 minutes to assemble. To give you an overview of the Bar Cart parts, the above picture is to help you put the various parts into perspective. Please read through the instructions below to familiarise yourself with the parts and steps before assembly.

Step 1

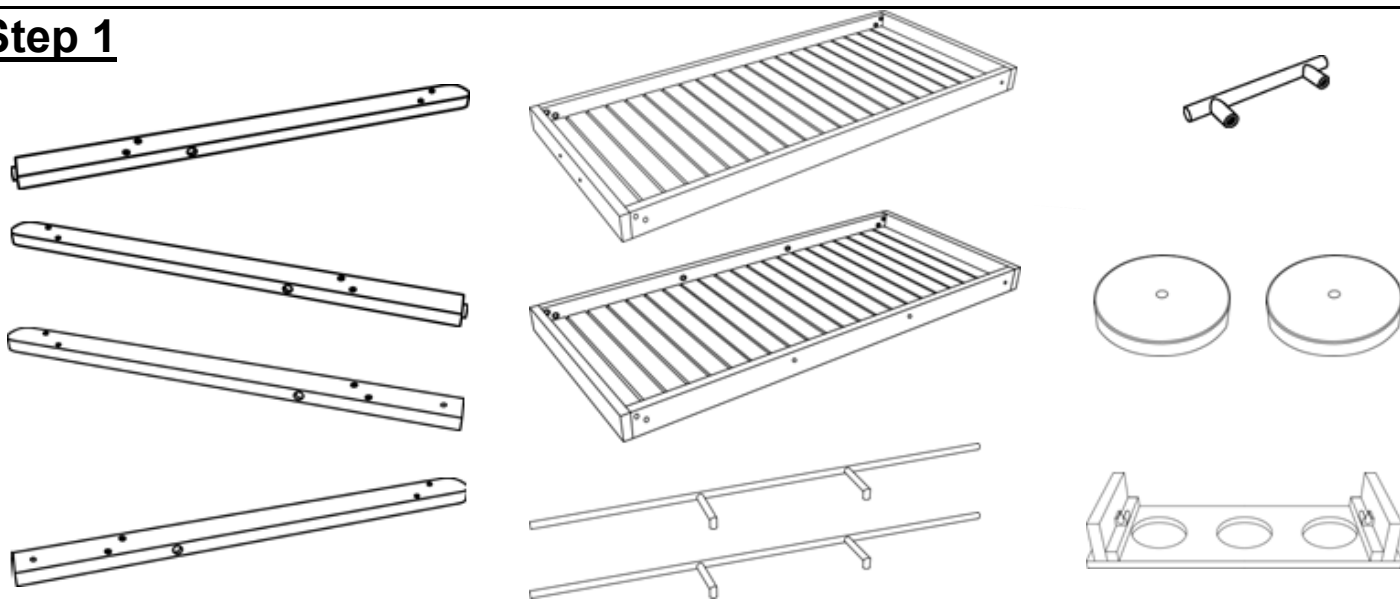

Unpack and place all parts on a clean, non-marring surface.

Step 2

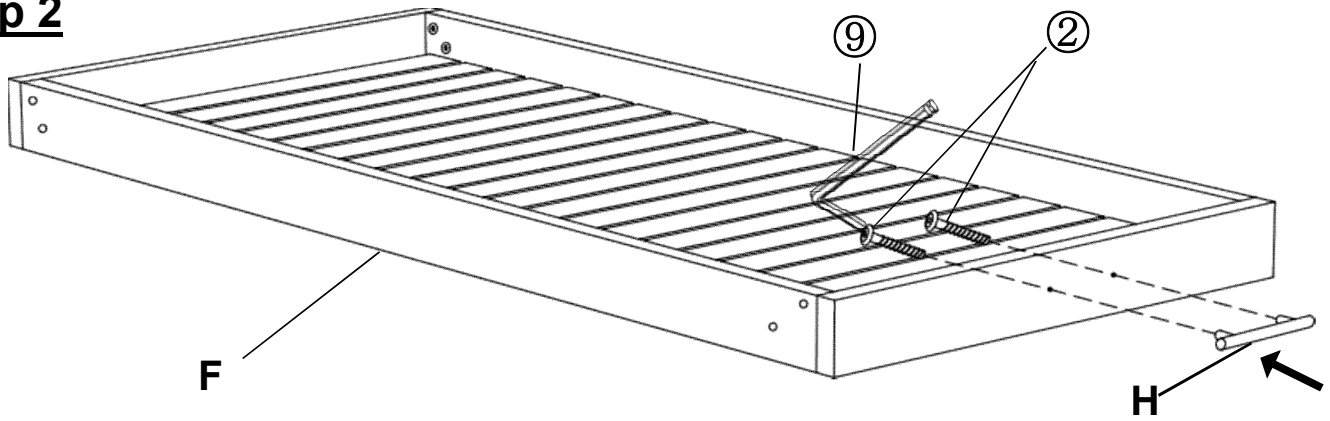

Place the Top Panel (F) with one side facing up, on a clean, soft surface as shown above. Attach the Handle (H) to the Top Panel (F) using Bolts ((2)) and the Allen Wrench ((9)) as shown above.

DO NOT FULLY TIGHTEN THE BOLTS.

Step 3

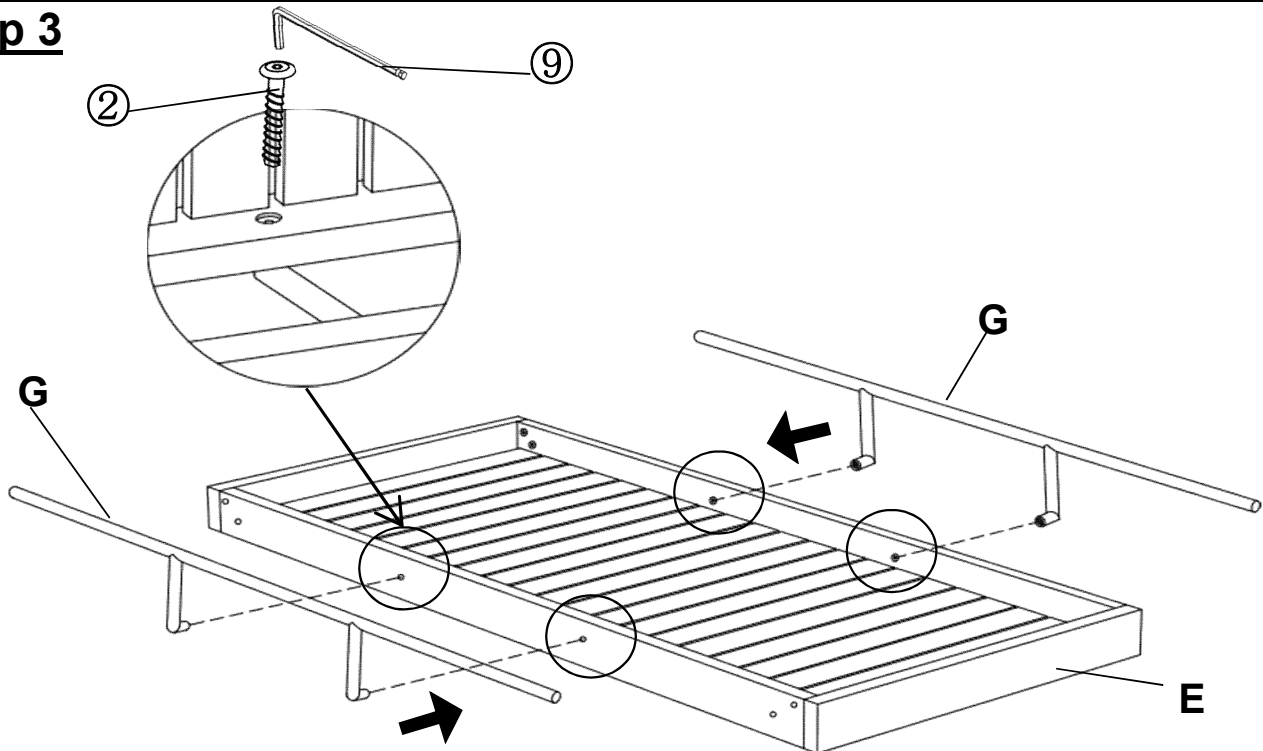

Place the Bottom Panel (E) with one side facing up, on a clean, soft surface as shown above.

Attach the Cross Bars (G) to the Bottom Panel (E) using Bolts ((2)) and the Allen Wrench ((9)) as shown above.

DO NOT FULLY TIGHTEN THE BOLTS.

Step 4

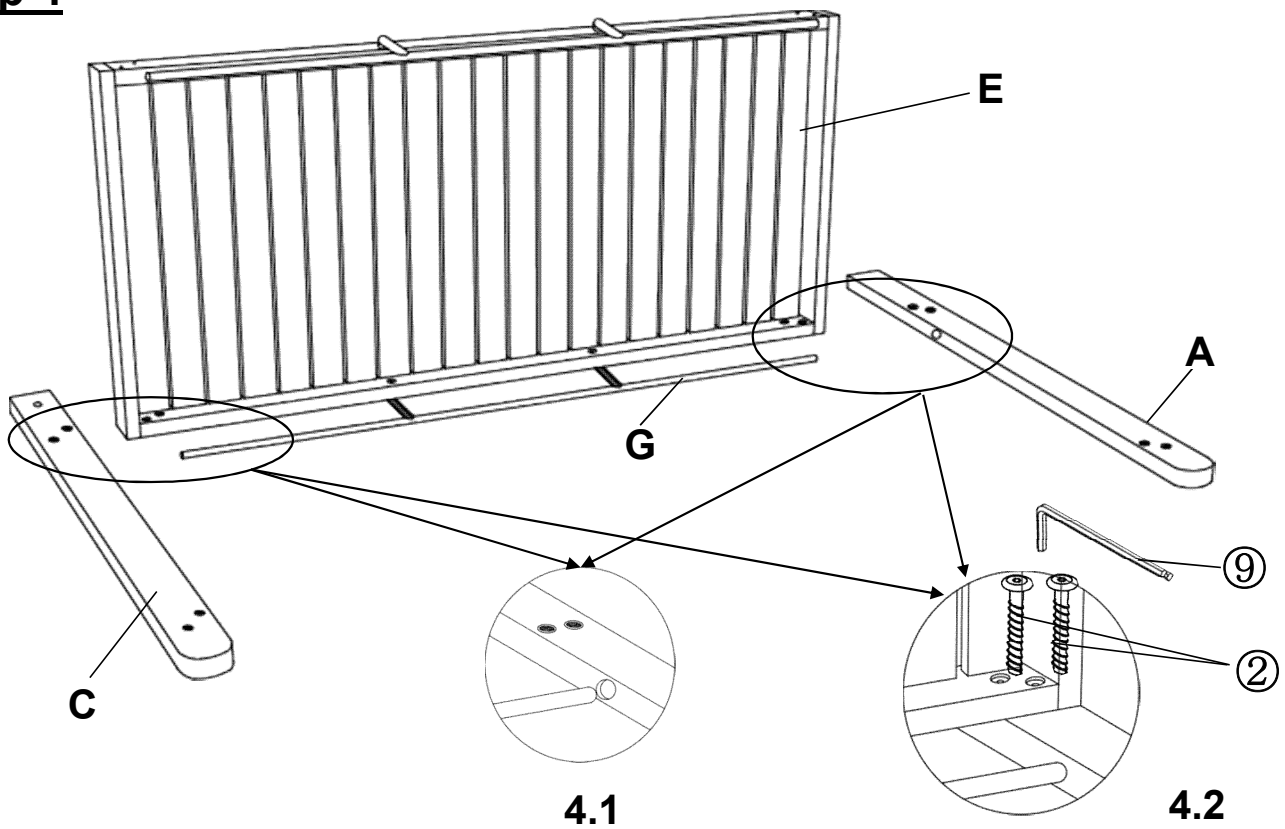

Place the Left Front Leg (A) and Left Back Leg (C) on a clean, soft surface as shown above.

4.1. With the help of your partner, align the Cross Bars (G) of the assembled part in Step 3 with the holes on the Left Front Leg (A) and Left Back Leg (C) as shown above.

4.2. Attach the Bottom Panel (E) to the Left Front Leg (A) and Left Back Leg (C) using bolts (2) and the Allen Wrench (9) as shown above.

DO NOT FULLY TIGHTEN THE BOLTS.

Step 5

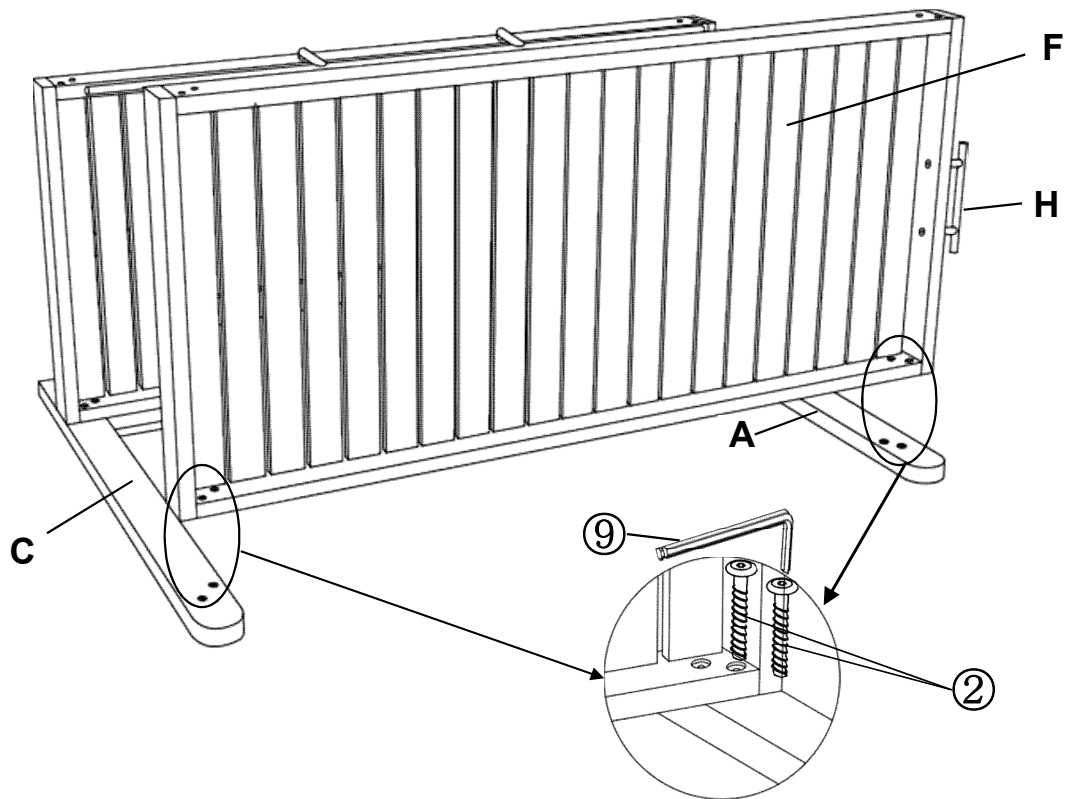

With the help of your partner, align the Top Panel (F) with the holes on the Left Front Leg (A) and Left Back Leg (C) of the assembled part in Step 4, then attach using Bolts (②) and the Allen Wrench (⑨) as shown above.

NOTE: The Handle (H) should be on the same side as the Left Front Leg (A)

DO NOT FULLY TIGHTEN THE BOLTS.

Step 6

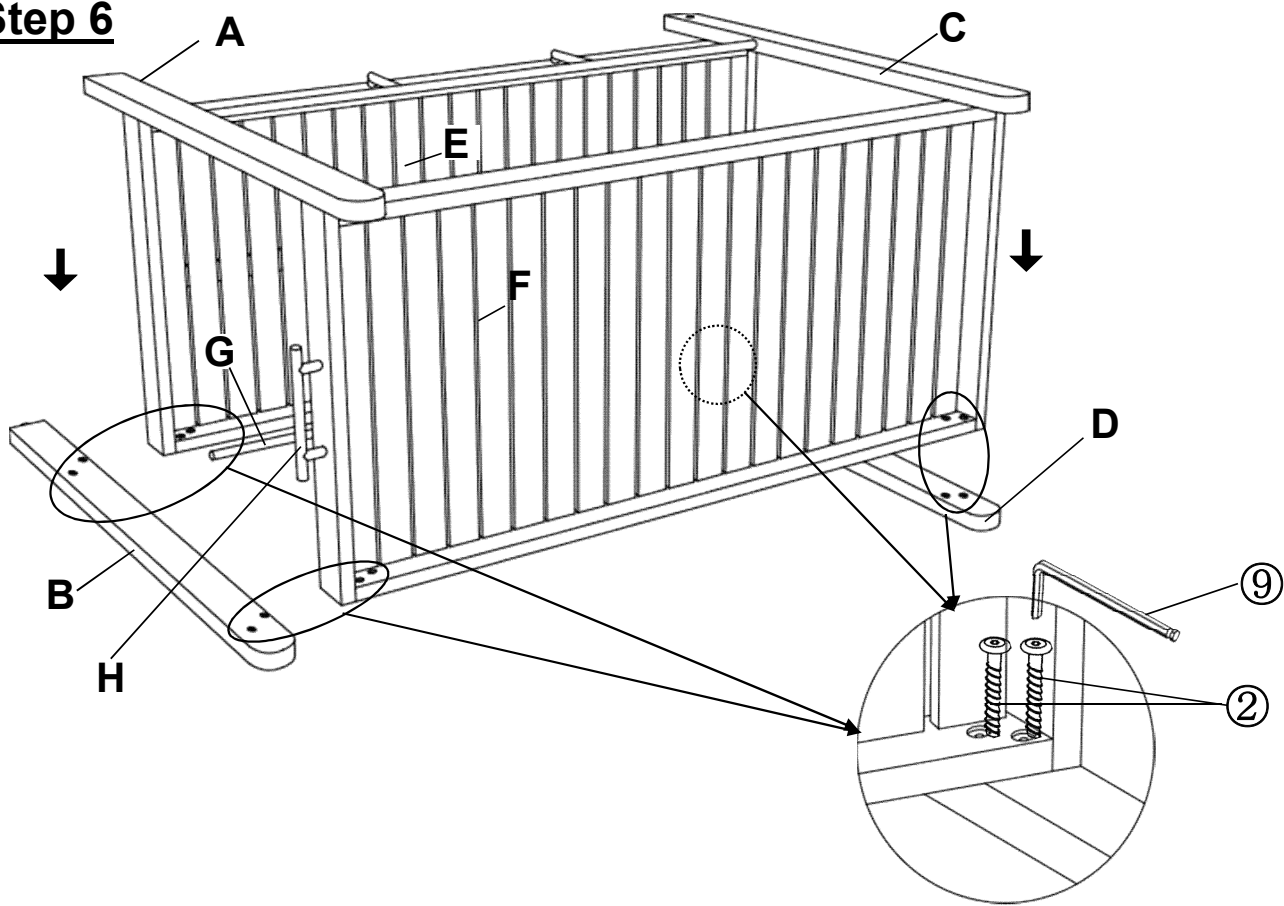

Place the Right Front Leg (B) and Right Back Leg (D) on a clean, soft surface as shown above.

With the help of your partner, turn the assembled part in Step 5 upside down.

Align the Bottom Panel (E), Top Panel (F), and Cross Bars (G) with the holes on the Right Front Leg (B) and Right Back Leg (D), then attach them using Bolts (2) and the Allen Wrench (9) as shown above.

NOTE: The Handle (H) should be on the same side as the Right Front Leg (B)

DO NOT FULLY TIGHTEN THE BOLTS.

Step 7

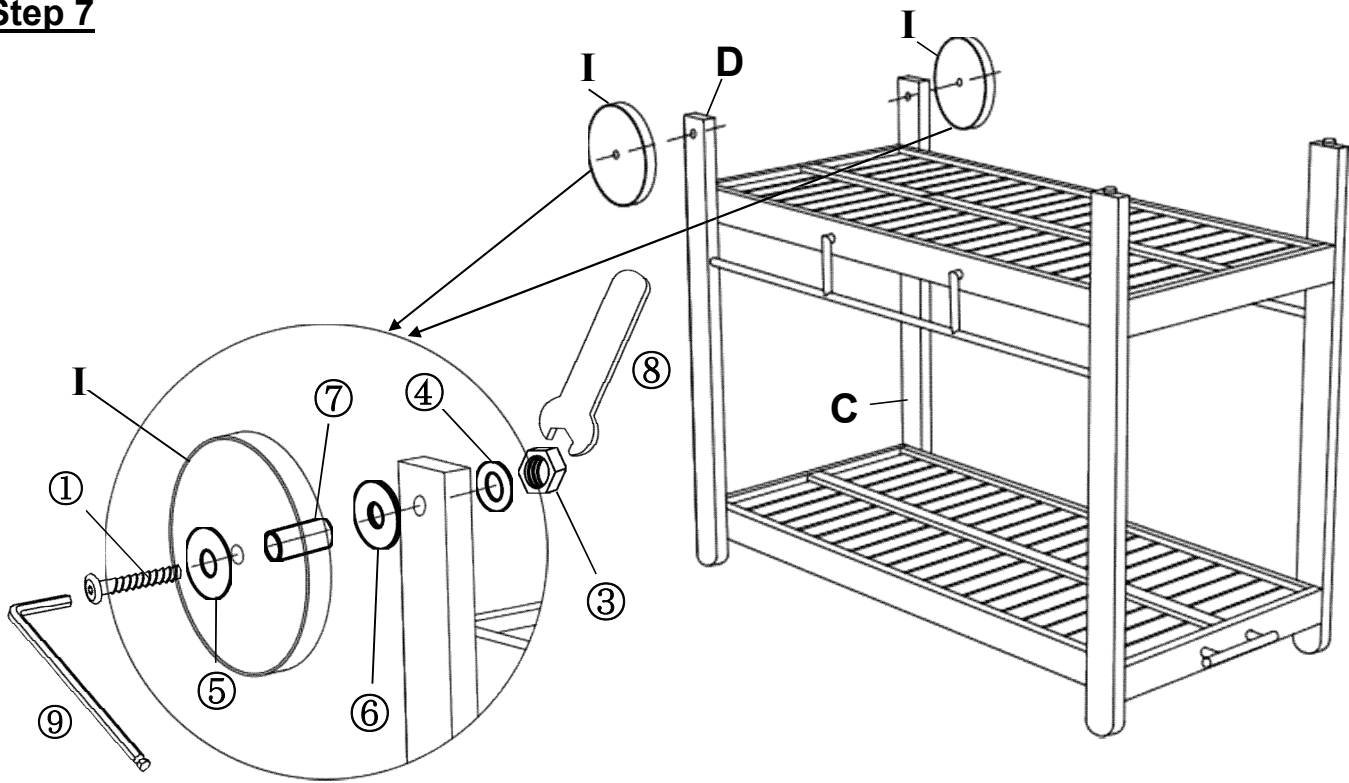

With the help from your partner, turn the assembled part in Step 6 face down onto the ground as shown above.

Attach the Wheels (I) to this assembled part by using the following sequence of hardware, from the outside to the inside of the Right Back Leg (D): Bolt (①), Flat Washer (⑤), Iron Tube (⑦), Wheels (I), and Flat Washer (⑥). On the **inside** of the **Right** Back Leg (D): Flat Washer (④), Nut (③) and Wrench (⑧). Use the Allen Wrench (⑨) to tighten the bolt as shown above.

Repeat the same process above to attach the remaining Wheel (I) to the Left Back Leg (C).
DO NOT FULLY TIGHTEN THE BOLTS.

Step 8

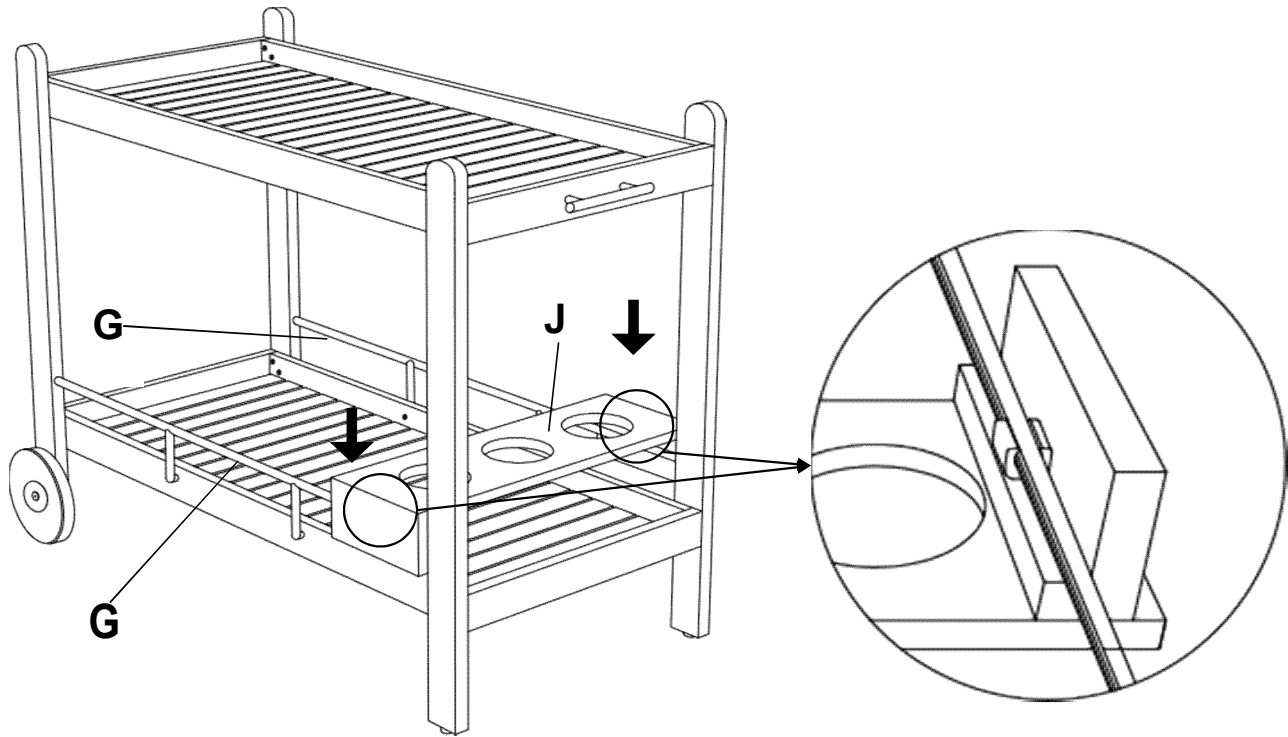

With the help from your partner, turn the assembled part in Step 7 right side up as shown above.

Insert the Bottle Holder (J) onto the Cross Bars (G) of the assembled part in Step 7 by pressing it downwards as shown above.

Place the Bar Cart on a **LEVEL SURFACE**.

Inspect it and make sure all parts are adequately connected.

EXERT pressure, downwards onto the Bar Cart with both hands. Check for wobbles.

This will help align all the parts at all the joint areas.

In a sequential manner, gradually tighten all Bolts at all joints until evenly secured.

Inspect the Bar Cart and make sure all parts are adequately connected. Whenever moving or lifting the Bar Cart, be sure to get support from your adult partner(s).

When tightening any Bolt, tighten it sequentially.

DO NOT fully tighten any Bolt fully and then move on to the next one. This could cause the frame to warp.

If there are any wobbles after tightening, loosen the Bolts and execute the same process.









WARNING!! IF Bar Cart IS NOT STABLE, IT COULD LEAD TO DAMAGE OF THE PRODUCT.

Ensure all Bolts are fully locked into position.

Your Bar Cart is ready to be used.

This Bar Cart can only be used on a flat, level surface.

Care & Maintenance

-  Do not put hot items directly on furniture surface
 -  Do not clean furniture with harsh cleansers or polish.
 -  To obtain the longest lifespan of your outdoor products, minimizing exposure to direct sunlight is recommended.
 -  Children should not climb or jump on the furniture.
 -  Do not write on furniture without a padded barrier to protect the surface.
 -  To obtain the longest lifespan of your outdoor products, avoid extended and lengthy exposure to rain, snow, and direct sunshine. Whenever possible cover the product and /or place under patio or awnings.
 -  Not for commercial use. For residential use only .
 -  Stains may be removed with mild soap solution and damp cloth.
-
-  Dust and pick-up spills using a clean, non-colored, lint-free cloth .