



















Assembly Instructions

Caution : You must read this before you proceed

Care & Maintenance

-   ● Not for commercial use. For residential use only .
-   ● Do not put hot items directly on furniture surface
-   ● Do not clean furniture with harsh cleansers or polish.
-   ● To obtain the longest lifespan of your outdoor products, minimizing exposure to direct sunlight is recommended.
-   ● Children should not climb or jump on the furniture.
-   ● Do not write on furniture without a padded barrier to protect the surface.
-   ● To obtain the longest lifespan of your outdoor products, avoid extended and lengthy exposure to rain, snow, and direct sunshine. Whenever possible cover the product and /or place under patio or awnings.
-   ● Stains may be removed with mild soap solution and damp cloth.
-   ● Dust and pick-up spills using a clean, non-colored, lint-free cloth .

Please look in the Side Table Top Panel for hardware packs.



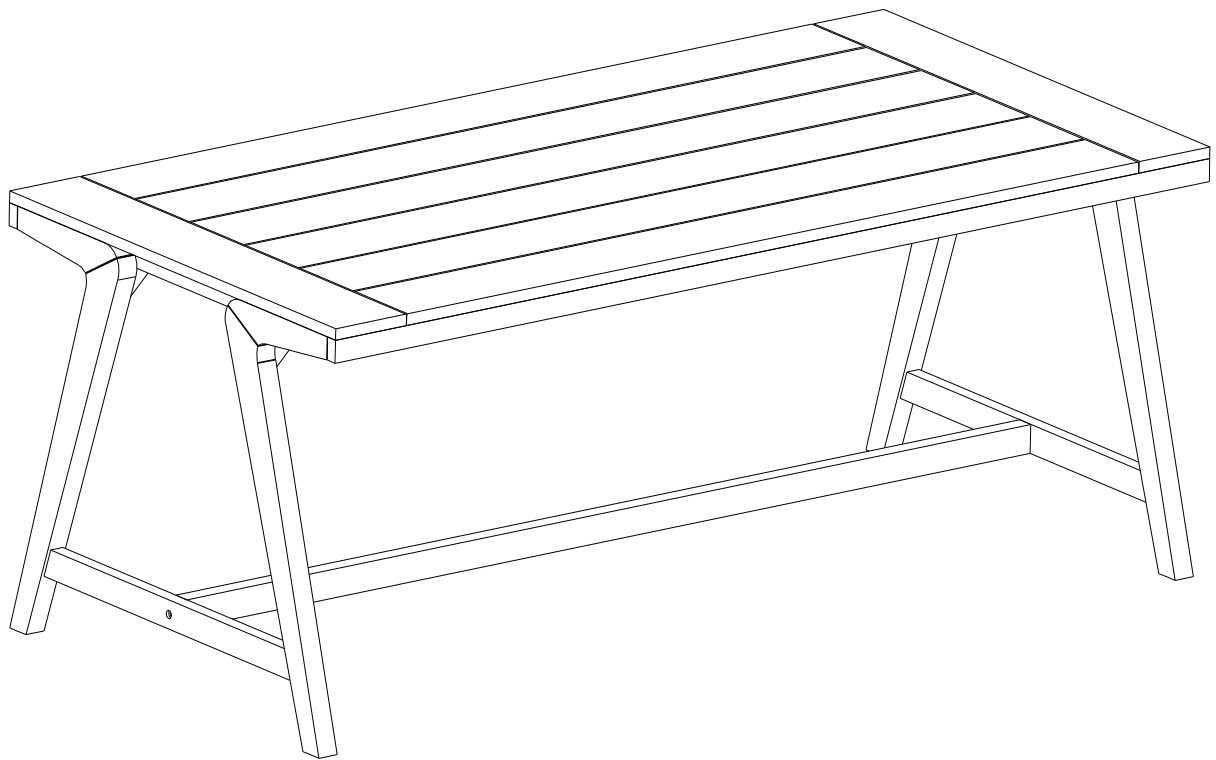

Table

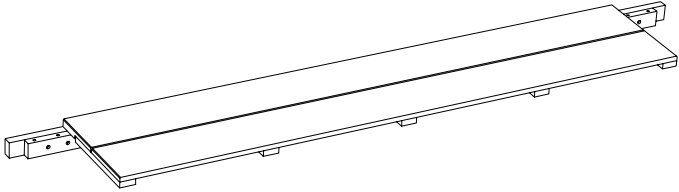
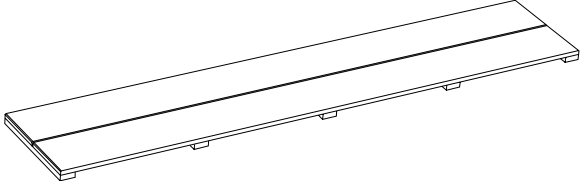
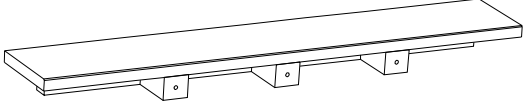
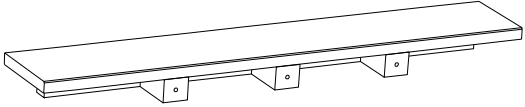
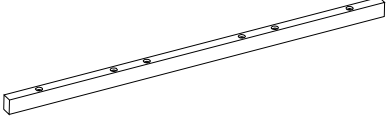
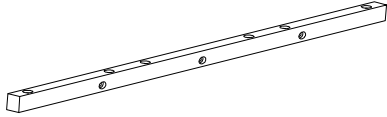
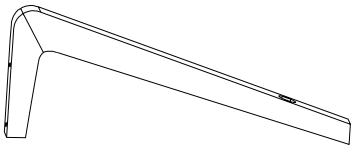
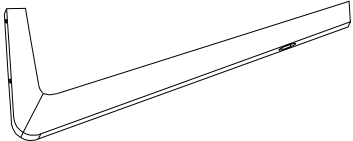
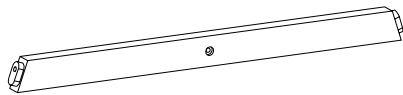
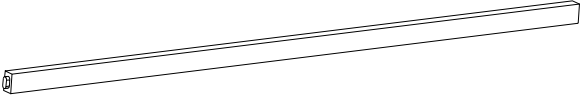
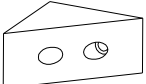

Parts List

Label	Picture	Description	QTY
A		Side Table Top Panel	2
B		Middle Table Top Panel	1
C1		Table wing Panel	1
C2		Table wing Panel	1
D		Middle Support Top	3
E		Side Support Top	2
F		Right Leg	2
G		Left Leg	2
H		Support Leg	2
I		Support Bar	1
K		Corner	4

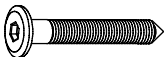
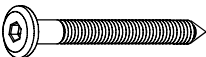
Hardware:

No.	Picture	Description	QTY
①		Bolt (M6x52mm)	17
②		Bolt (M6x45mm)	13
③		Screws (M6x45mm)	45
④		Screws (M6x70mm)	7
⑤		Allen Wrench	2

Assembly Preparation

Before Beginning Assembly:

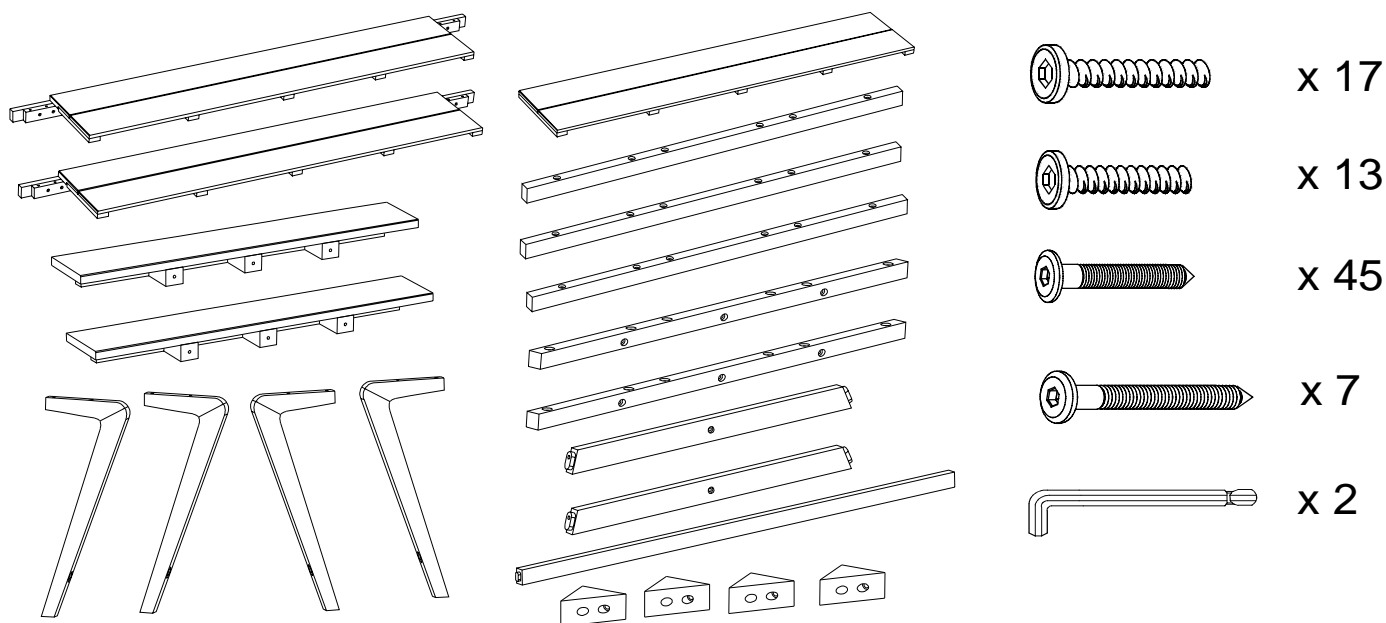

- Read instructions, cover to cover-



- Have 2 adults on hand for assembly-



- Do not assemble on flooring or carpet-



- Assemble on a clean non-marring surface (packing foam)-



- Save all packaging until finished-

Assembly Steps

OVERVIEW

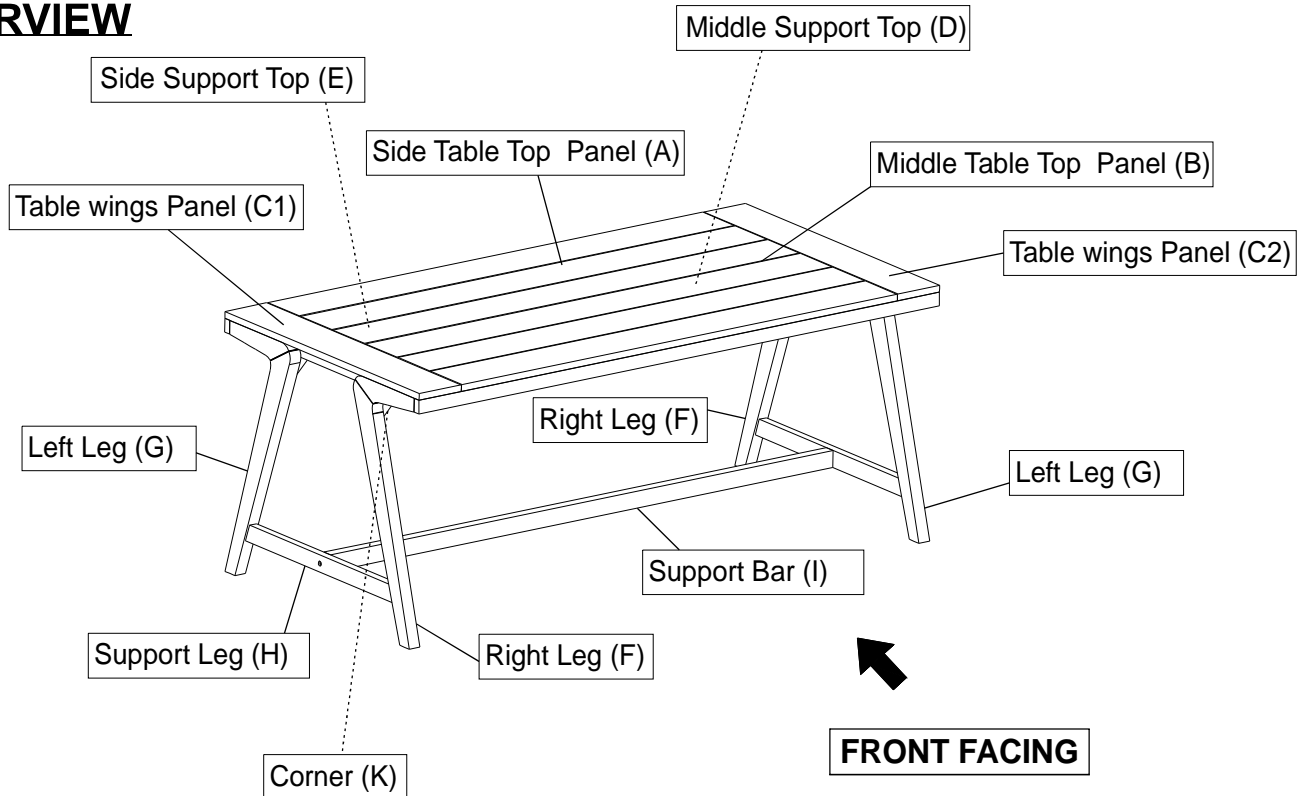

This Table has multiple parts and may require up to 30 minutes to assemble. To give you an overview of the Table parts, the above picture is to help you put the various parts into perspective. Please read through the instructions below to familiarise yourself with the parts and steps before assembly.

Step 1

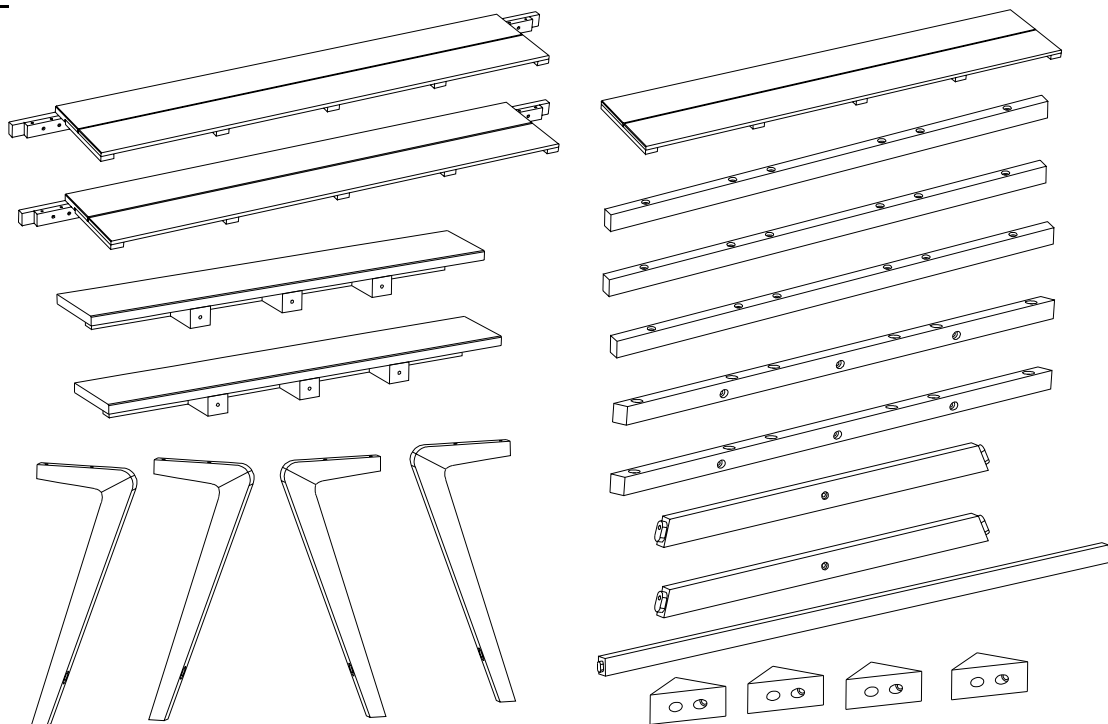

Unpack and place all parts on a clean, non-marring surface.

Step 2

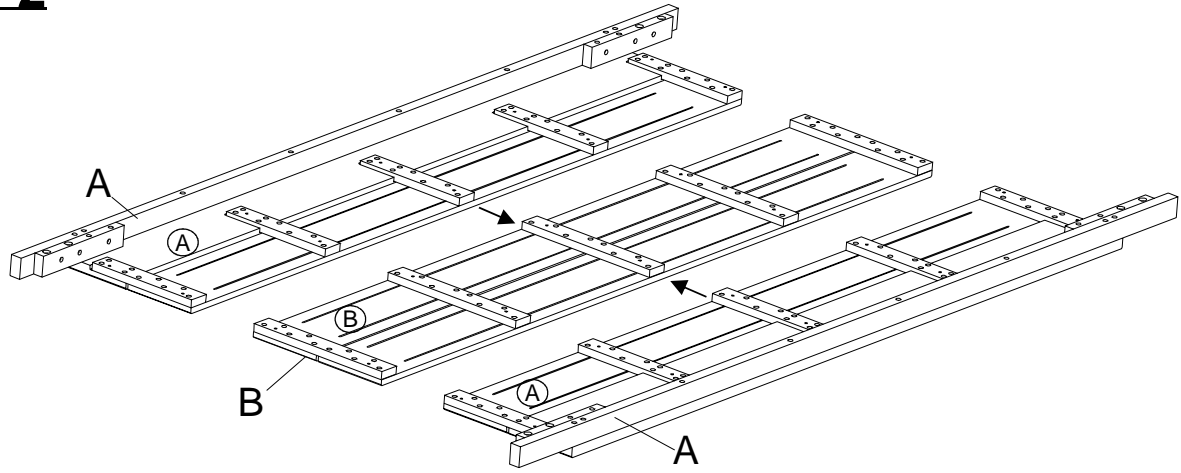

Place the Side Table Top Panel (A) and Middle Table Top Panel (B) on the surface as shown above. **Attention: Labels (A), (B) stuck on these parts are supposed to be on the same side once assembly as pictures shown above.**

Step 3

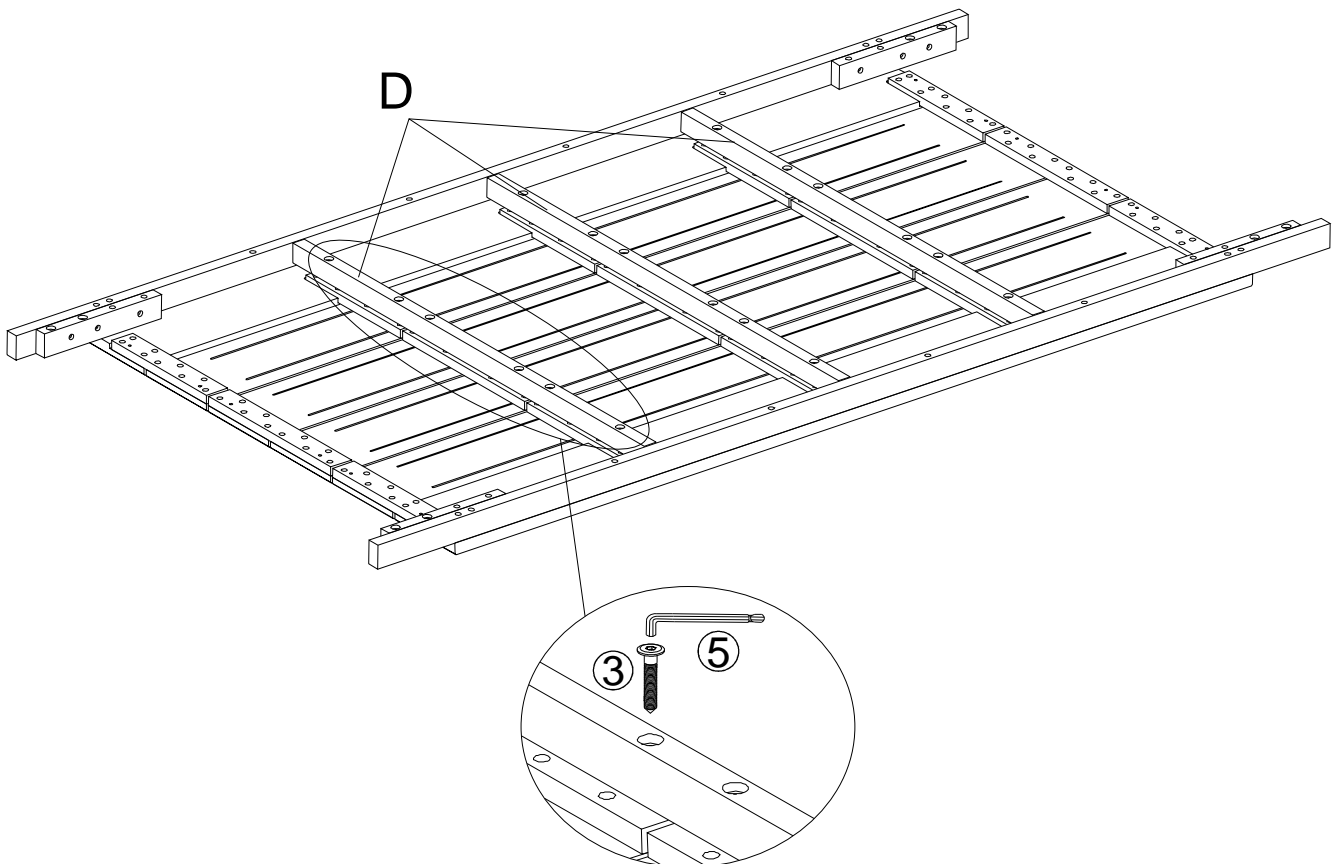

Attach the Middle Support Top (D) to the Side Table Top Panel (A) and Middle Table Top Panel (B) using Screws (③) with Allen Wrench (⑤) as shown in the picture above. **DO NOT fully tighten the Screws.**

Step 4

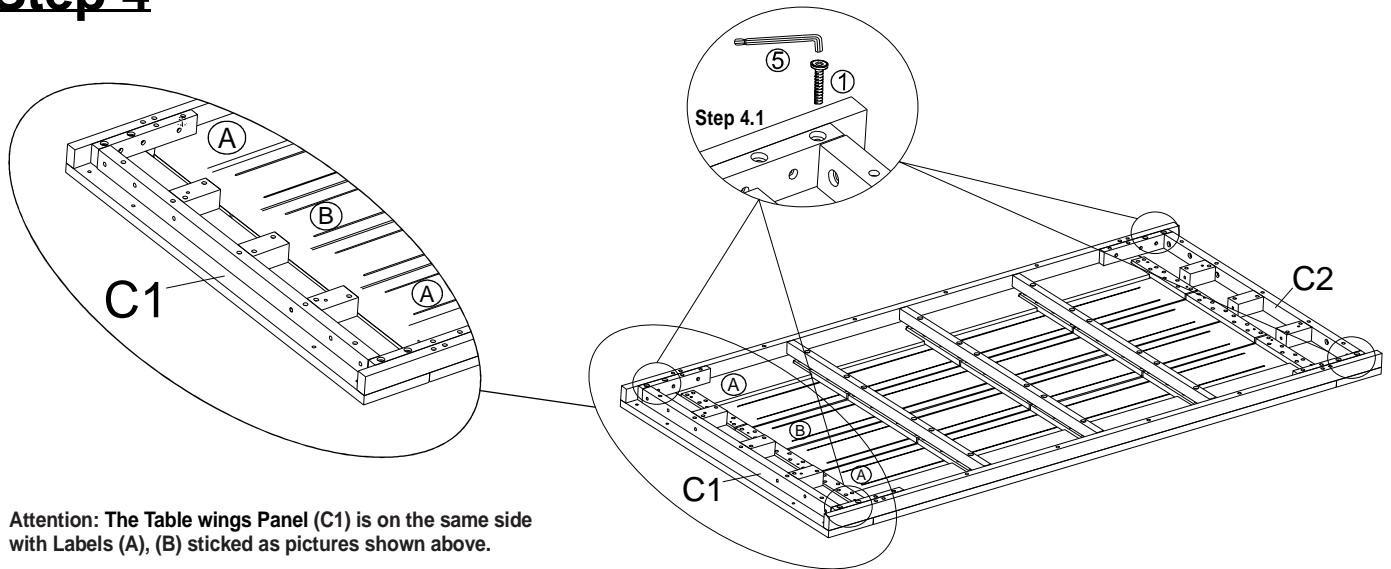

Attention: The Table wings Panel (C1) is on the same side with Labels (A), (B) stuck as pictures shown above.

With the help of your adult partner:

Step 4.1: Attach the Table wings Panel (C1) and the Table wings Panel (C2) to the assemble in step 3 using Bolts (1) with Allen Wrench(5) as Step shown in the picture above.

Attention: The Table wings Panel (C1) is on the same side with Labels (A), (B) stuck as pictures shown above.

Do not fully tighten the Bolts.

Step 5

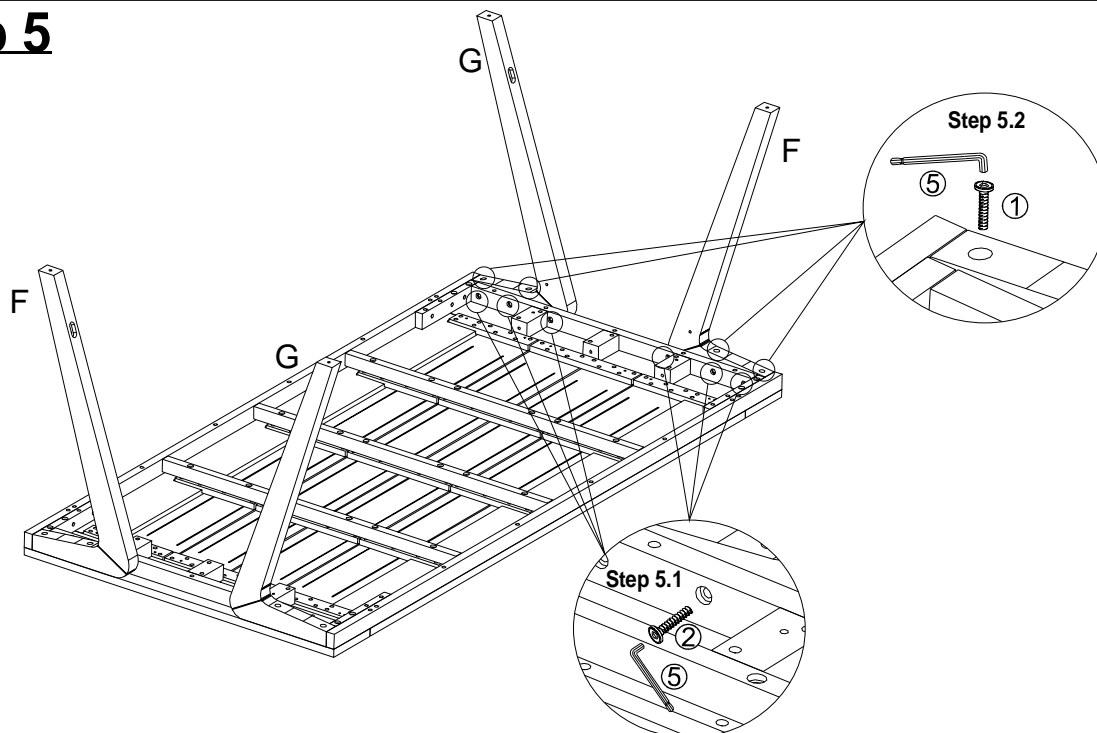

With the help of your adult partner:

Step 5.1: Attach the Right Leg (F), Left Leg (G) to the Table wings Panel (C) using Bolts (2) with Allen Wrench (5) as shown in the picture above.

Step 5.2: Attach the Right Leg (F), Left Leg (G) to the Table wings Panel (C) using Bolts (1) with Allen Wrench (5) as shown in the picture above.

Repeat the same process with the Right Leg (F) and Left Leg (G) second.

Do not fully tighten the Bolts.

Step 6

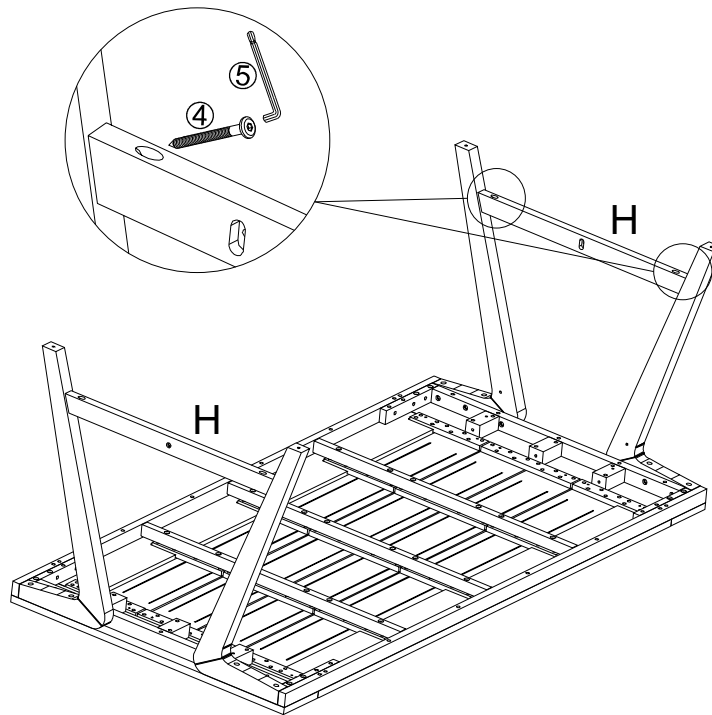

With the help of your adult partner attach the Support Leg (H) to the Right Leg (F) and Left Leg (G) using Screws (④) with Allen Wrench (⑤) as shown in the picture above. Repeat the same process with the Support Leg (H) second.
Do not fully tighten the Screws.

Step 7

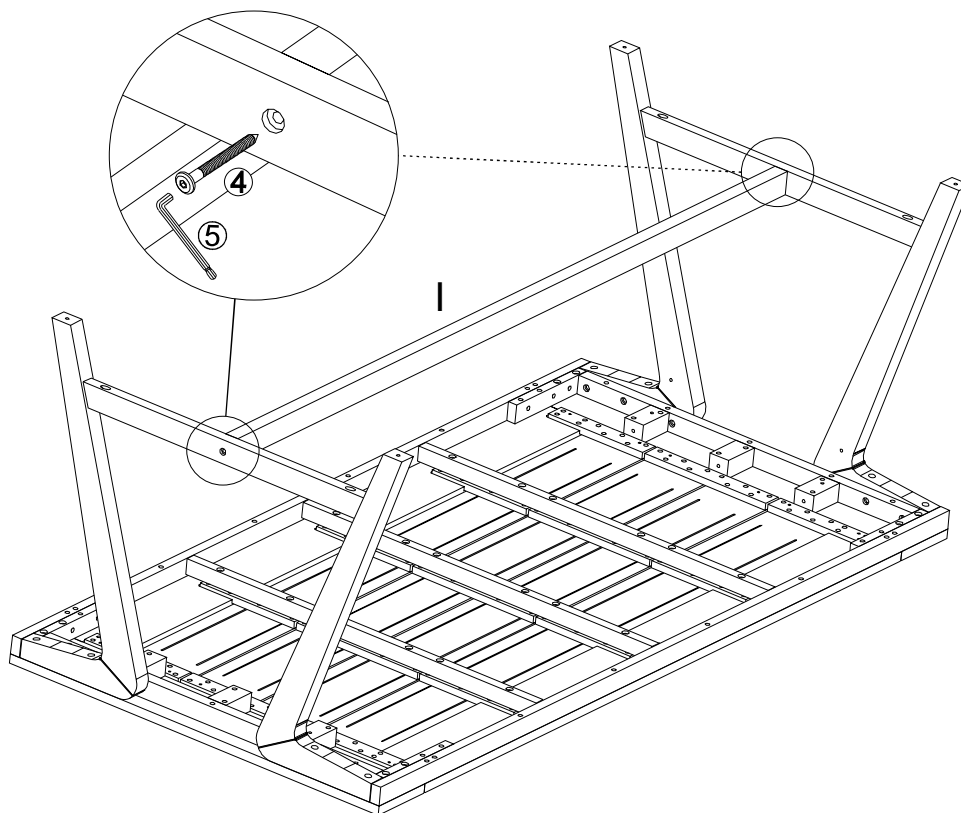

With the help of your adult partner, attach the Support Bar (I) to the Support Leg (H) using Screws (④) with Allen Wrench (⑤) as shown in the picture above.
Do not fully tighten the Screws.

Step 8

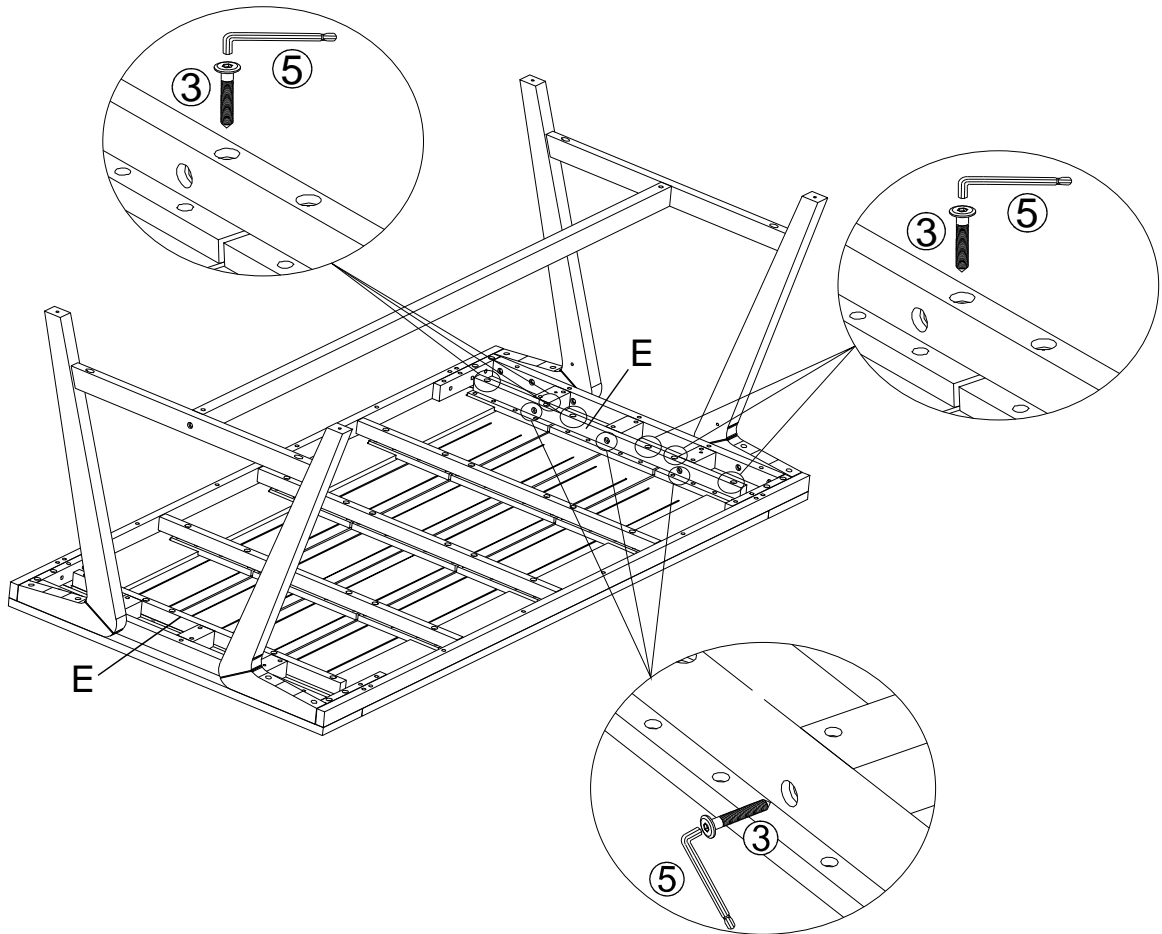

Attach the Side Support Top (E) to the Side Table Top Panel (A), Middle Table Top Panel (B) and Table wings Panel (C1, C2) using Screws (3) with Allen Wrench (5) as shown in the picture above. Repeat the same process with the Side Support Top (E) second.
DO NOT fully tighten the Screws.

Step 9

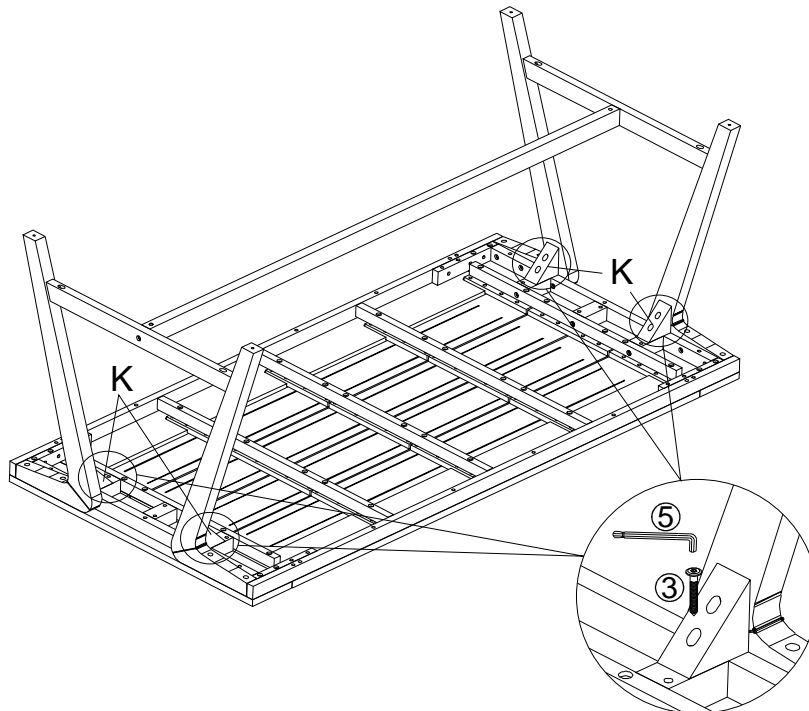

Attach the Corner (K) to the Right Leg (L), Left Leg (G) and Table wings Panel (C) using Screws (3) with Allen Wrench (5) as shown in the picture above.
Do not fully tighten the Screws.

Step 10

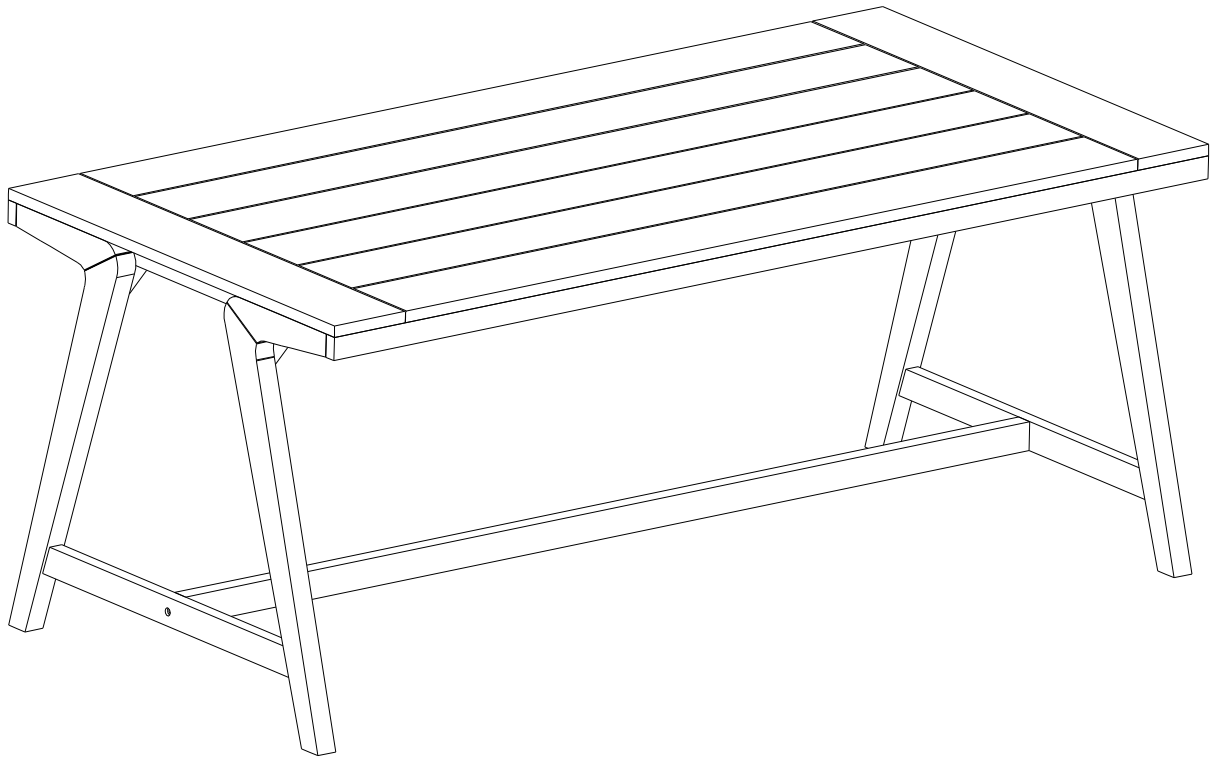

You are now at the FINAL step of this assembly.
In a sequential manner, drive in and fully tighten all bolts.
Thereafter, turn the table right way up.
The Table now is ready to be used.
Caution: This Table can only used on a flat, level surface.