

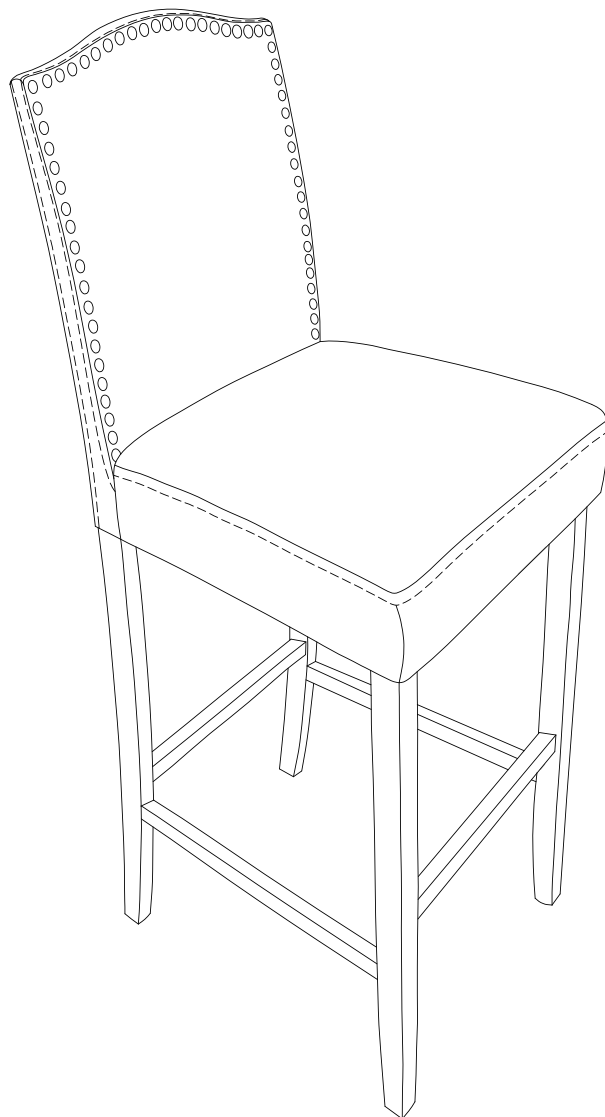





# Assembly Instructions

**Caution : You must read this before you proceed  
Please look in the bottom of seat frame for hardware packs and legs.  
Sets often ship in multiple boxes and may arrive a day or two apart**

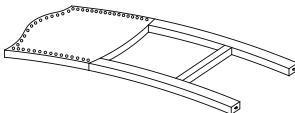



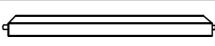
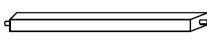

## Counter Chair

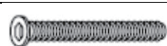

## Parts List

Part NO.	Picture	Description	QTY
A		Chair Back	1 PC
B		Chair Seat	1 PC
C		Left Front Leg	1 PC
D		Right Front Leg	1 PC
E		Left Side Rail	1 PC
F		Right Side Rail	1 PC
G		Front Rail	1 PC

## Hardware

Label	Picture	Description	QTY
1		Bolt(M8x75mm)	5 PCS
2		Bolt(M8x50mm)	6 PCS
3		Screw(M4x45mm)	7 PCS
4		Spring Washer	10 PCS
5		Washer	10 PCS
6		Allen Key	1 PC
7		Screwdriver	Not provided

# Assembly Preparation

## Before Beginning Assembly:

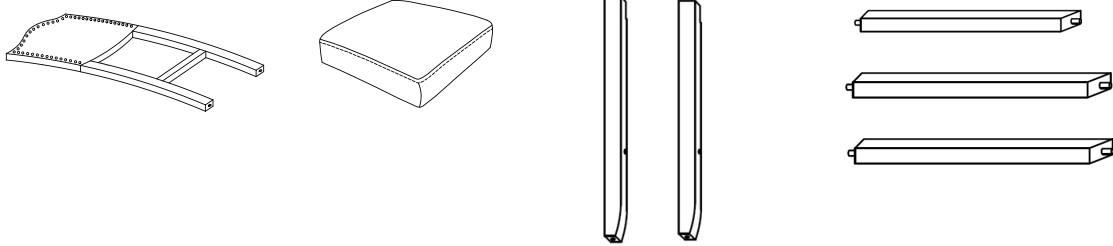

<b>Pack A</b> for assembling the Seat Frame(B) to the hind legs of Chair Back(A)	Bolt(M8x75mm)+ Washer +Spring Washer	
<b>Pack B</b> for assembling the Seat Frame(B) to the Front Leg Left(C) & Front Leg Right(D)&the Seat Frame (B) to the horizontal panel of Chair Back (A) at the central point	Bolt(M8x50mm)+ Washer +Spring Washer+Allen Key	
<b>Pack C</b> for assembling the Left Side Rails(E) &Right Side Rails(F) to the Left Front Leg (C) &Right Front Leg (D)	Screw(M4x45mm)	
<b>Pack D</b> for assembling the Left Side Rails(E) &Right Side Rails(F) to the Chair Back (A)	Screw(M4x45mm)	
<b>Pack E</b> for assembling the Front Rail(G) to the Front Leg	Screw(M4x45mm)	



- Read instructions, cover to cover-



- Have 2 adults on hand for assembly-



- Do not assemble on flooring or carpet-



- Assemble on a clean non-marring surface (packing foam)-



- Save all packaging until finished-

# Assembly Steps

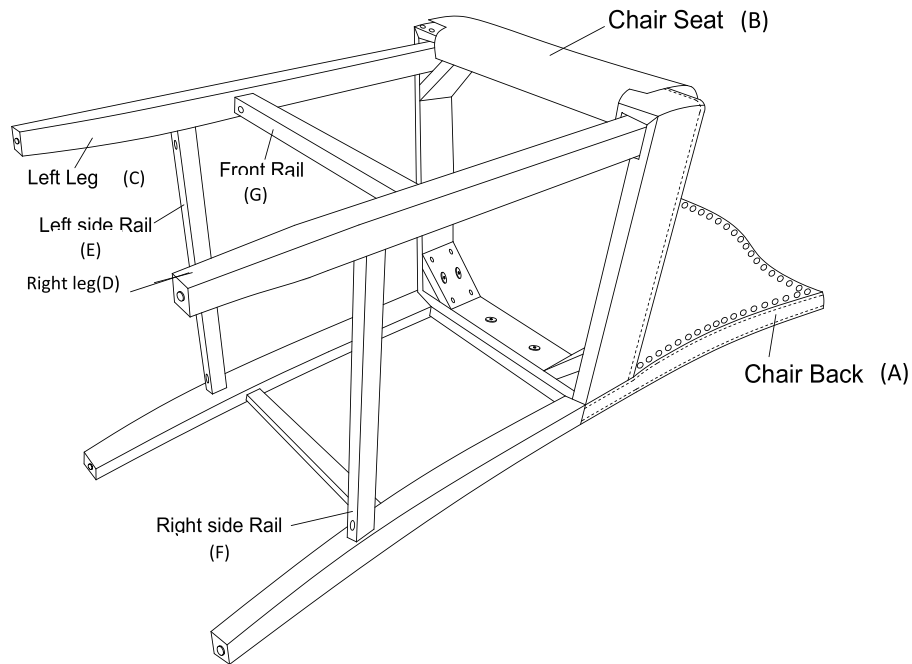

This Counter Chair has multiple parts and may require up to 30 minutes to assemble. To give you an overview of the Bookshelf parts, the above picture is to help you put the various Table parts into perspective.

Please read through the instructions herebelow to familiarise yourself with the parts and steps before assembly.

## Step 1

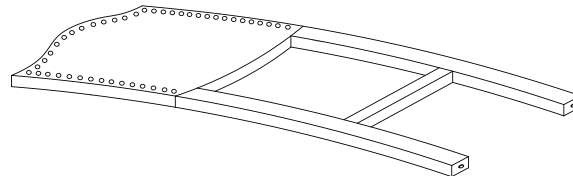

A. Chair Back

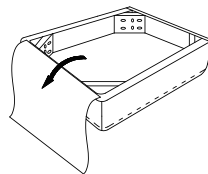

B. Chair Seat with Black Calico/magicTapes

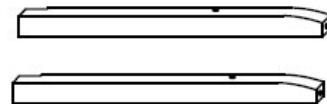

C. Front Left Leg & D. Front Right Leg

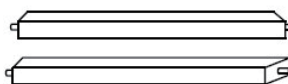

E. Left Side Rail & F. Right Side Rail

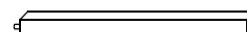

G. Front Rail

Place the Chair Back(A) and Chair Seat(B) on a clean, non-marring surface.  
Remove the Seat Base Cover from the underside of the Chair Seat(B) and take out all of the Parts and Hardware.

**Step 2**

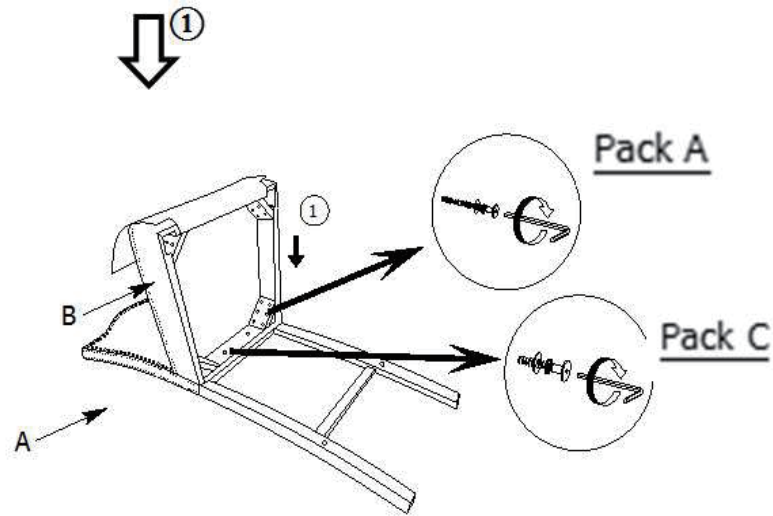

Align the mounting positions of the Chair Back(A) and Chair Seat Frame(B).  
Use your left hand to push the seat frame floorwards, depicted by Arrow 1, this action helps to ensure the Chair Seat(B) is pressed towards to the Chair Back(A) with no gap between them.  
Then, lock the middle mounting point by using Hardware Pack A and the corner mounting points by using Hardware Pack A & Pack B with The Allen Key(6),  
**Caution : At this stage, LOOSELY FASTEN these bolts**

**Step 3**

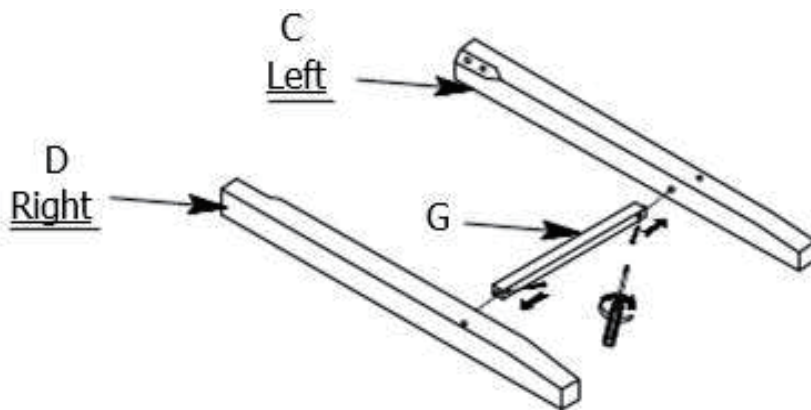

Insert the Front Rail(G) into the oval housing of Left Front Leg (C) & Right Front Leg (D) as shown above.  
Then, use Hardware Pack E to attach the Front Rail(G) to the Left Front Leg (C) & Right Front Leg (D).  
**At this stage, LOOSELY FASTEN these bolts**

**Step 4**

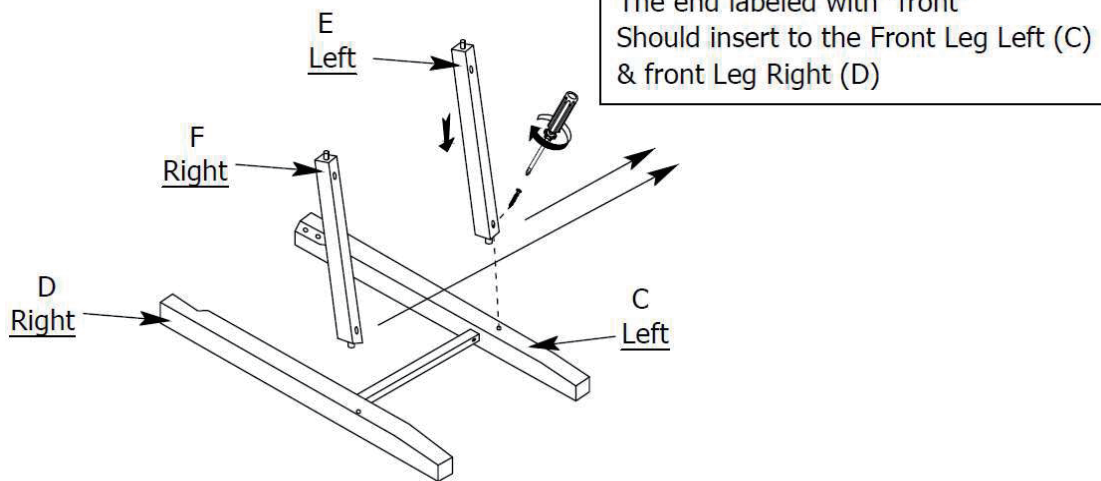

Insert the Left Side Rail(E) into the oval housing of Left Front Leg(C),use Hardware Pack C to attach the the Left Side Rail(E) to the Left Front Leg (C);  
Insert the Right Side Rail(F) into the oval housing of Right Front Leg(D)  
Then, use Hardware Pack C to attach the Right Side Rail(F) to Right Front Leg (D).  
At this stage, **LOOSELY FASTEN these bolts**

**Step 5**

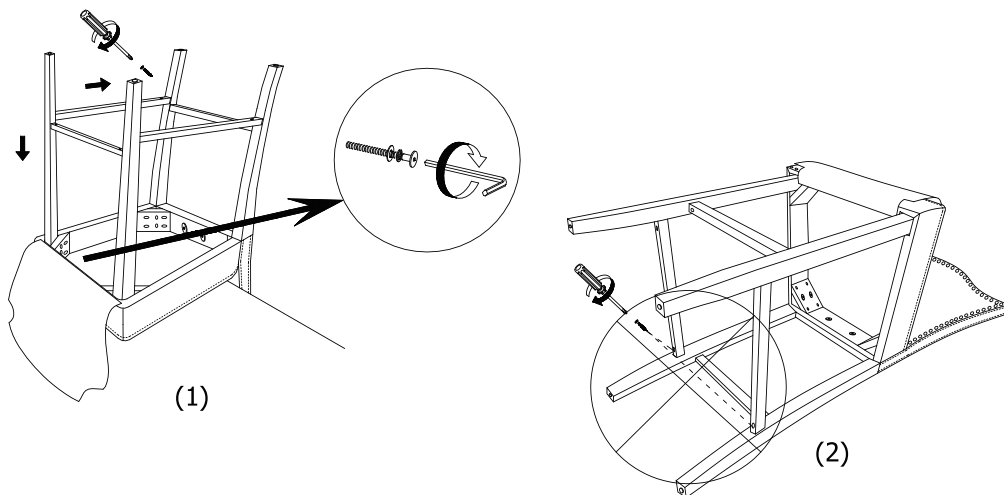

Next, place the chair onto the side of a table as seen in Picture 1.  
You will now have the chair bottom and legs facing skywards.  
Insert the assembled unit from Step 3 into the Chair Seat (B).  
**WARNING!! DO NOT POSITION THE FRONT LEG AS SHOWN IN PICTURE 2 .**  
**THIS PICTURE SHOWS THE CHAIR BACK STAYS AGAINST THE GROUND and THE LEGS HORIZONTAL IN MIDAIR.**  
Then use Hardware Pack D to attach the Side Rails with the Front and Hind Legs.  
At this stage, **LOOSELY FASTEN these bolts**

**Step 6**

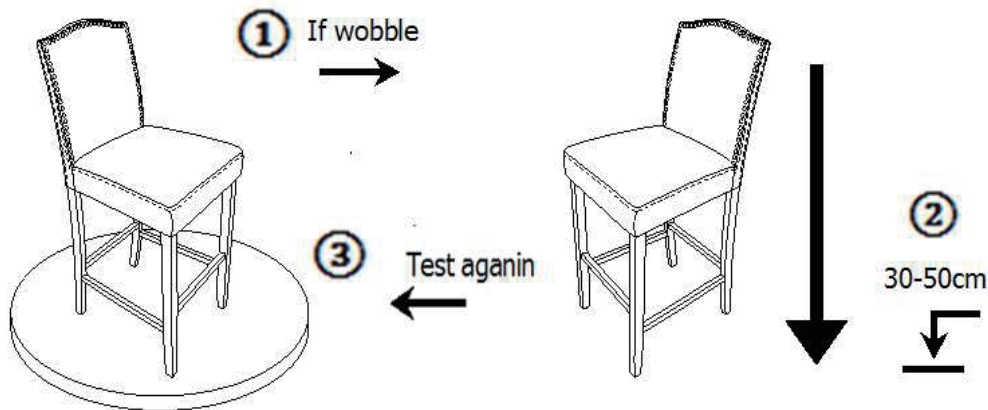

Place the chair on a Level Surface to check if it wobbles.

If it wobbles, lift the chair some 30cm to 50cm high from the ground, keep your feet and toes well away from the drop zone, and drop the chair freely and vertically with the four legs, hitting the ground at the same time.

This **Drop Test** will help to ensure that all the bolts and gaps to all reach full alignment. test again for evenness on a **Level Surface**.

If no wobbles are found, proceed to tighten all the Bolts.

**Caution: When tightening the Bolts, tighten sequentially.**

**Do not tighten any screw fully and then towards the next one, this would cause the frame to warp. If it still wobbles, loosen the bolts and execute this same drop test.**

**If the Chair is not Stable it could lead to damage to the product.**

**Step 7**

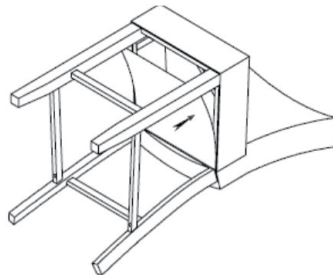

Place the Seat Base Cover back underneath the chair seat (as shown in picture) from where it was removed from originally.





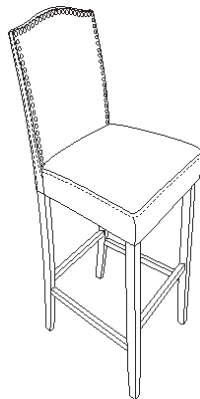





Smooth down with your hand on the Magic Tape on all 4 sides at the edge of the seat box.

**Step 8**



Turn the chair right way up, it is now ready for use.

## Care & Maintenance

- |   |   |
|---|---|
|  | • Furniture may scratch floors. We recommend using furniture pads to protect your floors. |
|  | • Do not put hot items directly on furniture surface.                                     |
|  | • Do not clean furniture with harsh cleansers or polish.                                  |
|  | • Do not place furniture under direct sunlight.   |
|  | • Do not place furniture near heating or cooling vents.                                   |
|  | • Do not write on furniture without a padded barrier to protect the surface.              |
|  | • Do not place furniture outside . For indoor use only.                                   |
|  | • Not for commercial use. For residential use only.                                       |
|  | • Stains may be removed with mild soap solution and damp cloth.                           |
|  | • Children should not climb or jump on the furniture.                                     |
|  | • Dust and pick-up spills using a clean, non-colored, lint-free cloth.                    |

## Questions & Answers about Proposition 65

- What is Proposition 65?

Proposition 65 requires businesses to provide warnings to Californians about significant exposures to chemicals that cause cancer, birth defects or other reproductive harm. These chemicals can be in the products that Californians purchase, in their homes or workplaces, or that are released into the environment. By requiring that this information be provided, Proposition 65 enables Californians to make informed decisions about their exposures to these chemicals.

Proposition 65 also prohibits California businesses from knowingly discharging significant amounts of listed chemicals into sources of drinking water.

Proposition 65 requires California to publish a list of chemicals known to cause cancer, birth defects or other reproductive harm. This list, which must be updated at least once a year, has grown to include approximately 900 chemicals since it was first published in 1987.

- What types of chemicals are on the Proposition 65 list?

The list contains a wide range of naturally occurring and synthetic chemicals that include additives or ingredients in pesticides, common household products, food, drugs, dyes, or solvents. Listed chemicals may also be used in manufacturing and construction, or they may be byproducts of chemical processes, such as motor vehicle exhaust.

- What does a warning mean?

If a warning is placed on a product label or posted or distributed at a workplace, a business, or in rental housing, the business issuing the warning is aware or believes that it is exposing individuals to one or more listed chemicals.

By law, a warning must be given for listed chemicals unless the exposure is low enough to pose no significant risk of cancer or is significantly below levels observed to cause birth defects or other reproductive harm.

Where can I get more information on Proposition 65?

- If you have specific questions on the administration or implementation of Proposition 65, you can contact OEHHA's Proposition 65 program at [P65.Questions@oehha.ca.gov](mailto:P65.Questions@oehha.ca.gov), or by phone at (916) 445-6900.