

Assembly Instructions

Caution : You must read this before you proceed

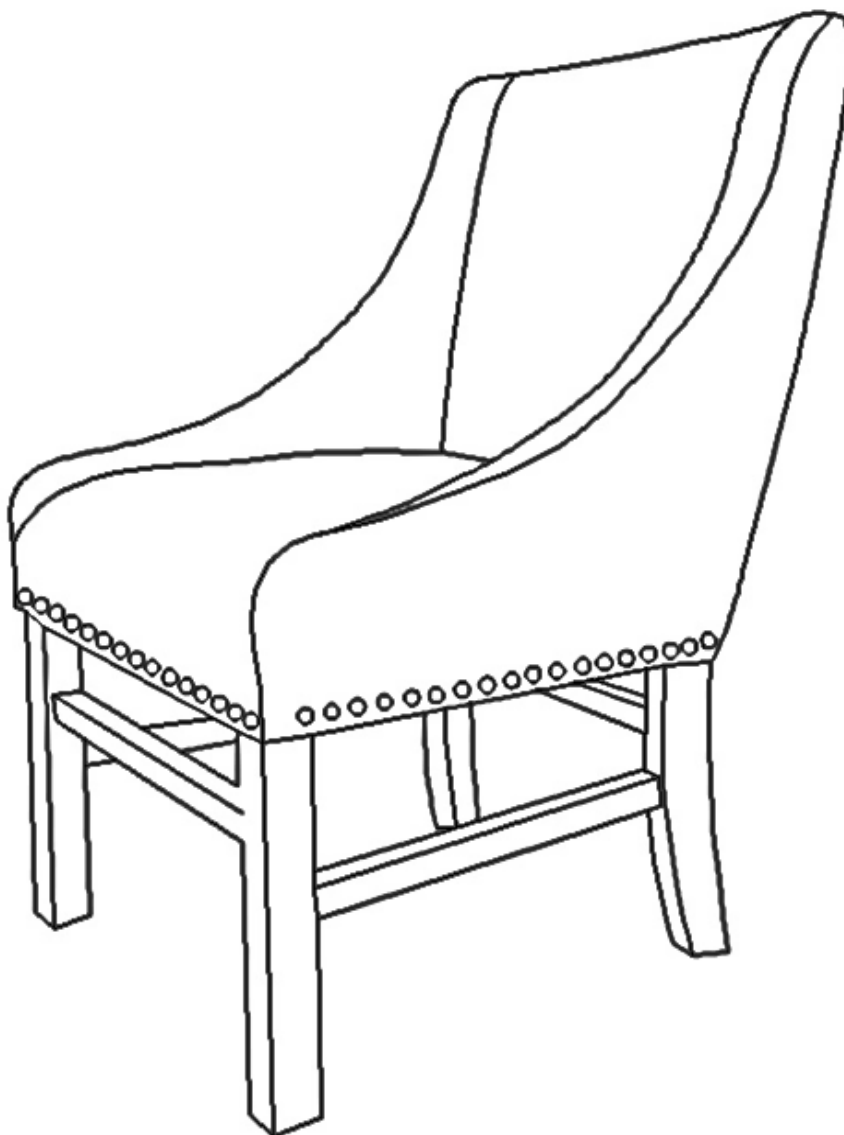

Bar Stool



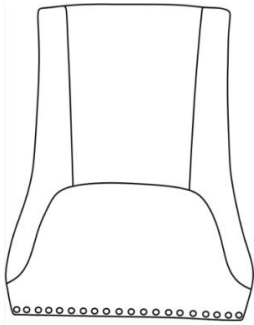
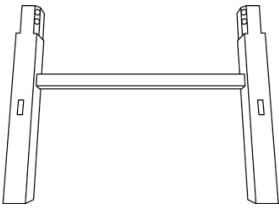
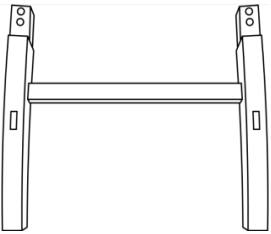
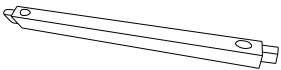
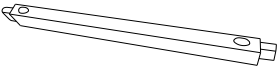



Parts List

Label	Picture	Description	QTY
A		Chair Back and seat	1
B		Front Leg Frame (Label B)	1
C		Hind Leg Frame (Label C)	1
D		Left Side Rail (Label D)	1
E		Right Side Rail (Label E)	1

Hardware

Label	Picture	Description	QTY
①		Long Bolt (M8*60MM)	9
②		Spring Washer	9

③		Washer	9
④		Screw (M4*50mm)	5
⑤		Allen Key	1
⑥		Screwdriver	1

Assembly Preparation

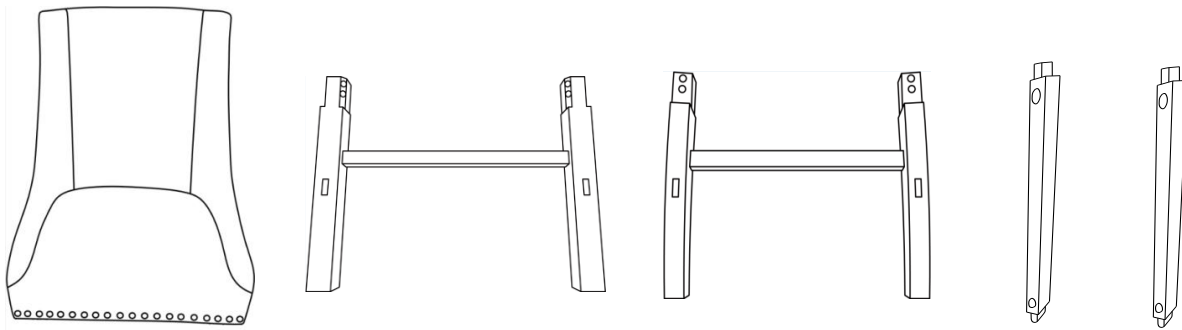

Pack A - for assembling the Front Leg Frame(B) & Hind Leg Frame(C) to the Chair Back and seat(A)

Long Bolt
Spring Washer
Washer
Allen Key

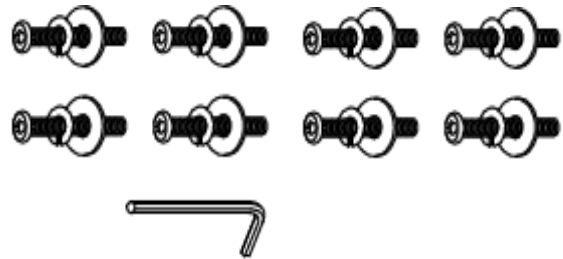

Pack B for assembling the Left Side Rail (D) & Right Side Rails (E) to the Front Leg Frame (B) and Hind Leg Frame(C)

Screw
Screwdriver

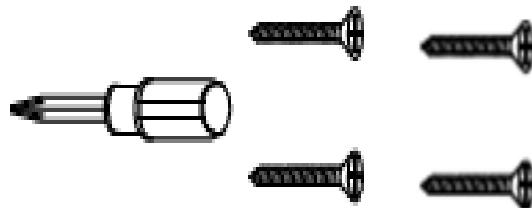



- Read instructions, cover to cover-



- Have 2 adults on hand for assembly-



- Do not assemble on flooring or carpet-



- Assemble on a clean non-marring surface (packing foam)-



- Save all packaging until finished-

Assembly Steps

Parts Introduction

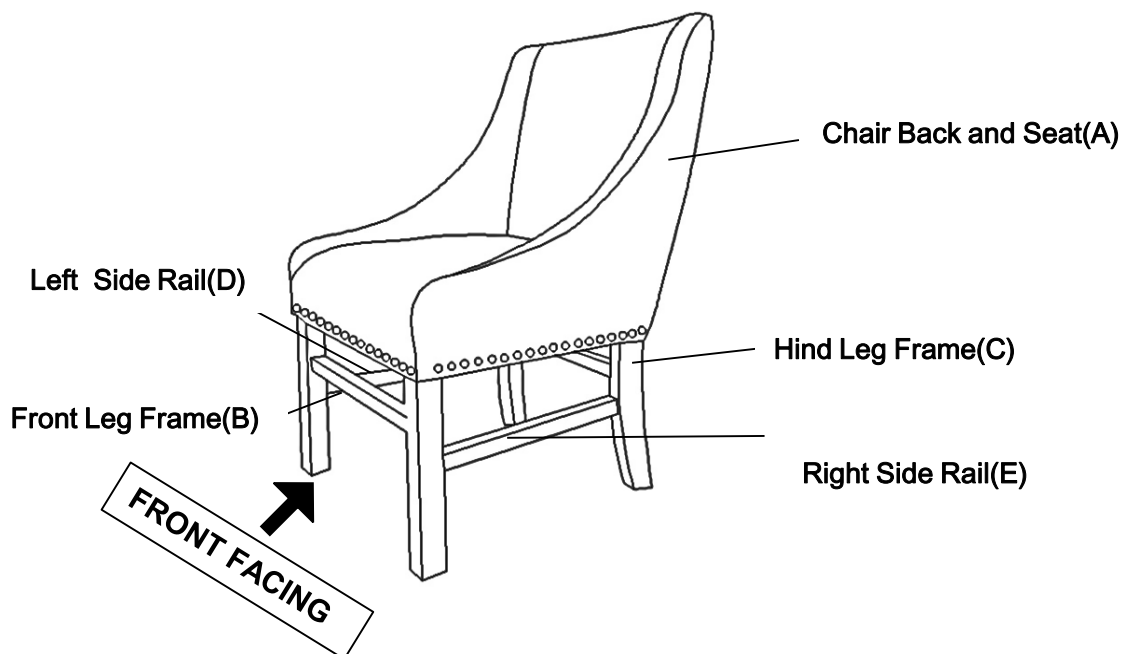

This Bar Stool has multiple parts and may require up to 30 minutes to assemble. To give you an overview of the Bar Stool parts, the above picture is to help you put the various Bar Stool parts into perspective. Please read through the instructions to familiarise yourself with the parts and steps before assembly.

Step 1

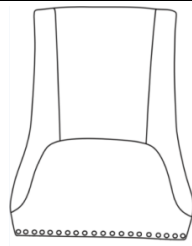

A. Chair Back and seat

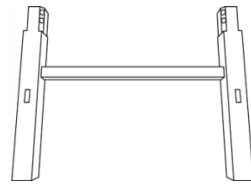

B. Front Leg Frame

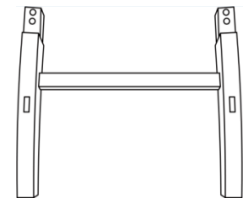

C. Hind Leg Frame

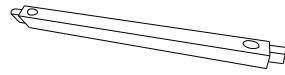

D. Left Side Rail

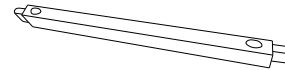

E. Right Side Rail

Place the Chair Back and seat(A) and Front Leg Frame (B), Hind Leg Frame (C), Left Side Rail (D)&Right Side Rail (E) on a soft surface to avoid any scratches or damages to the product and then take out the hardware.

Step 2

Step : 2.1

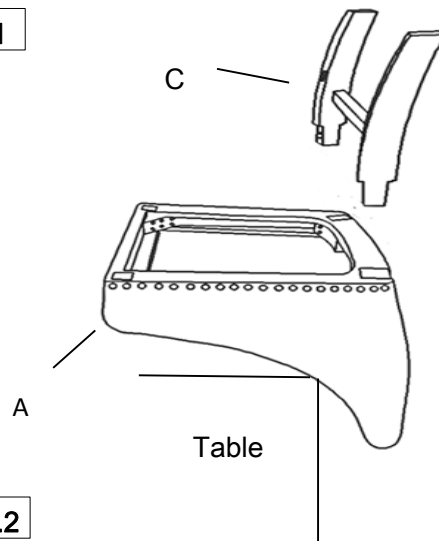

Step : 2.2

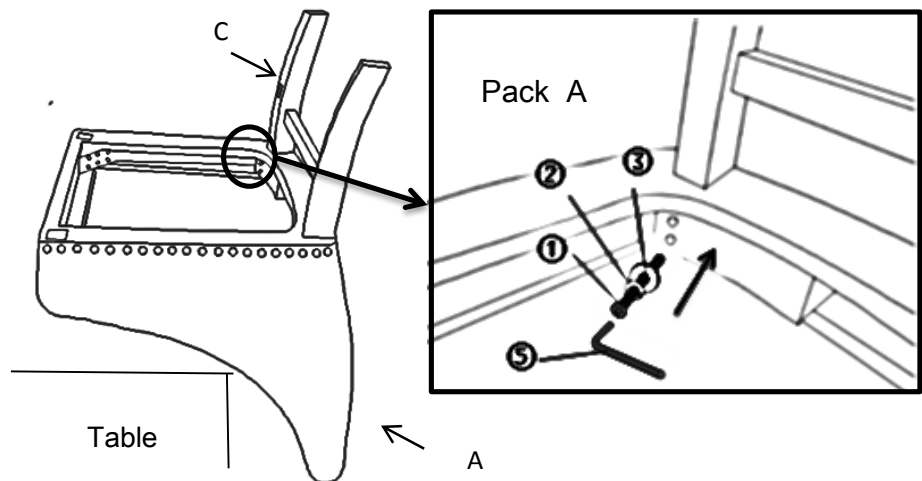

2.1 Place the chair onto the side of a table as seen in picture show.

With your assistant help to hold the Hind Leg frame(C) insert to the Chair Back and Seat (A).

2.2 Then attach the Hind Leg Frame(C) to the Chair Back and Seat(A) using Pack A .

At this stage, only LOOSELY FASTEN the Bolts.

Step 3

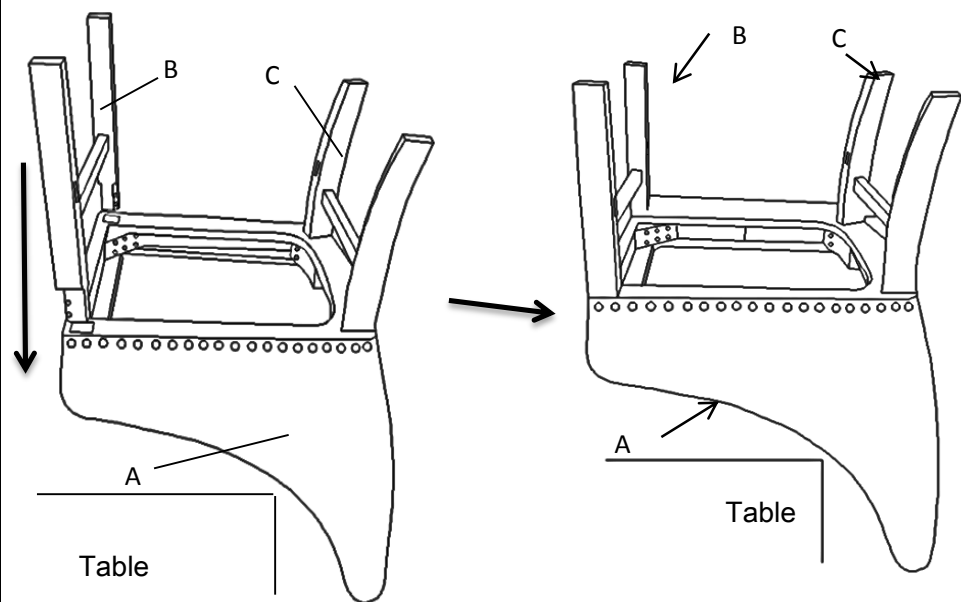

Then hold the Front Leg frame(B) insert to the Chair Back and Seat (A).

Step 4

Step : 4.1

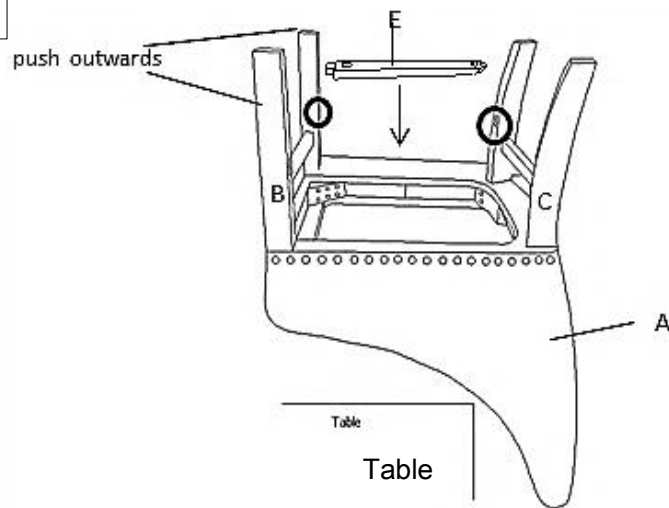

Step : 4.2

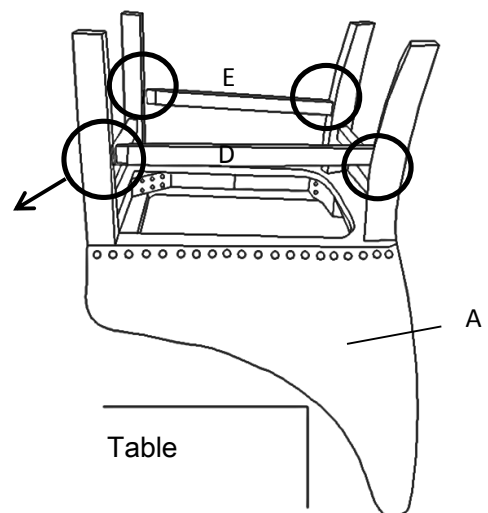
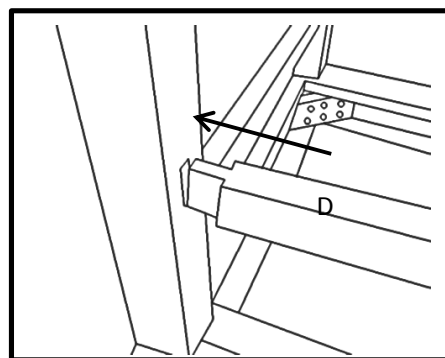

4.1 Place Right Side Rail(E) into the housing of the Front Leg Frame(B) and Hind Leg Frame(C). You may need to apply a little pressure to the leg frames - pushing outwards, so as to enable the Side Rail(E) to be slotted into position.

4.2 Repeat the same process to install the Left Side Rail(D).

Step 5

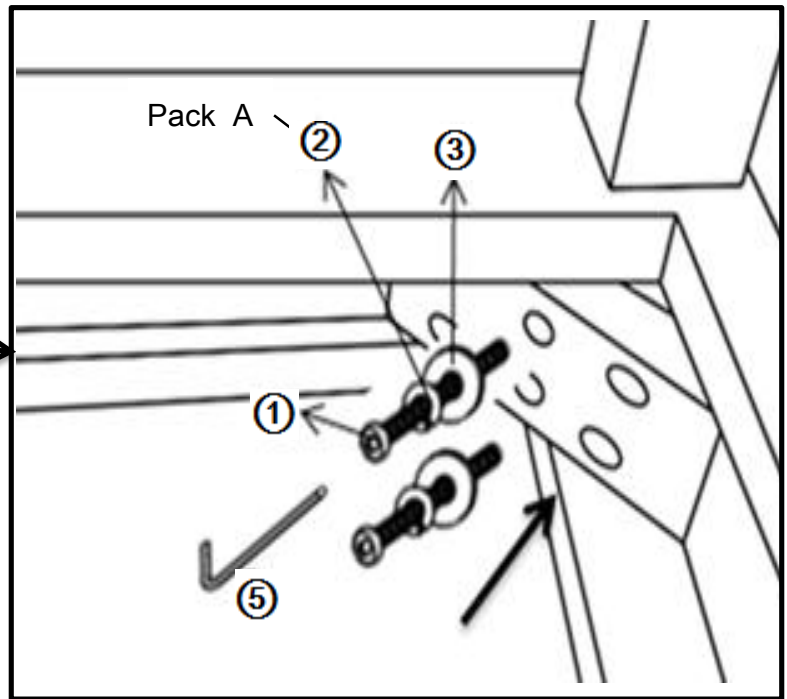
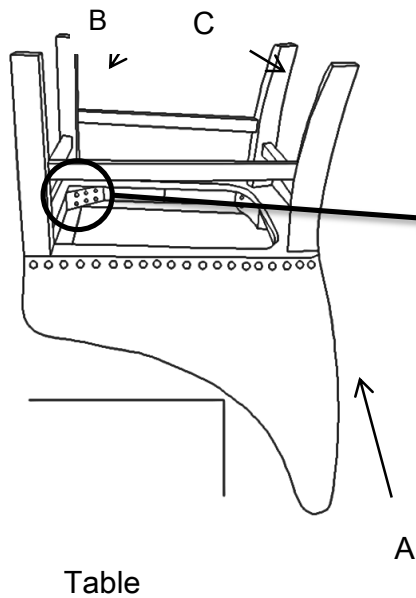

Attach the Front Leg Frame(B) to the Chair Back and Seat(A) using Pack A .
At this stage, only LOOSELY FASTEN the Bolts.

Step 6

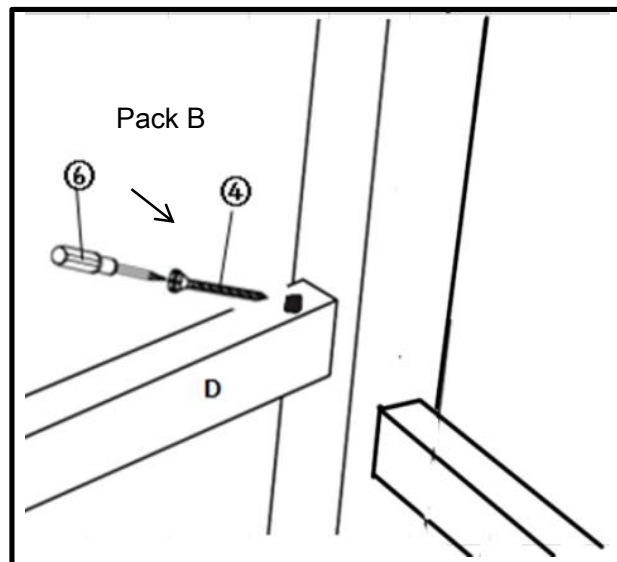
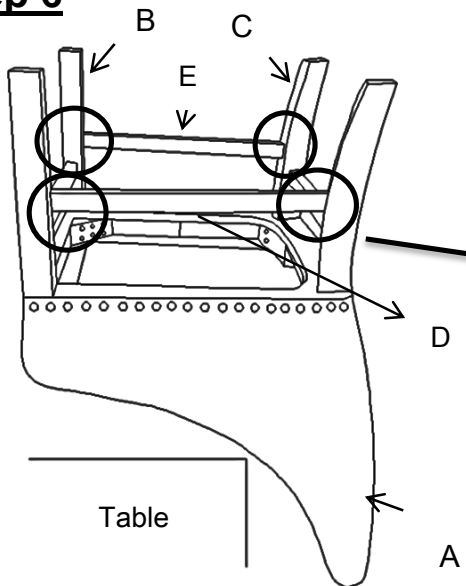

Then use Pack B to attach Left Side Rail(D) and Right Side Rail(E) to Front Leg Frame(B) and Hind Leg Frame(C).
At this stage, only LOOSELY FASTEN the Screws.

Step 7

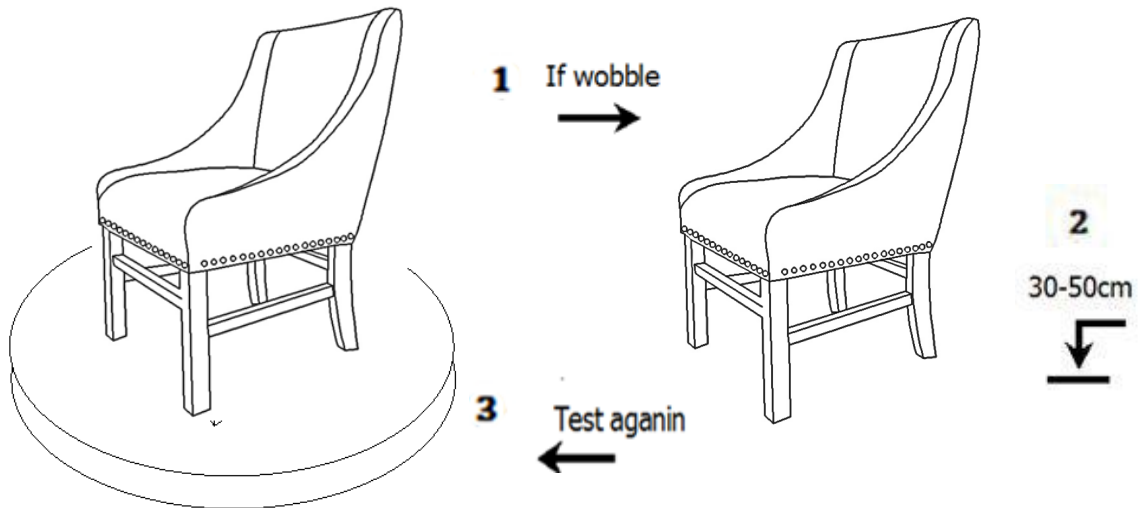

Place the Barstool on a Level Surface to see if it wobbles.

If it wobbles, lift the Stool to some 30cm to 50cm height from the ground.

Keep your feet and toes well away from the drop zone.

Drop the chair freely and vertically with the four legs, hitting the ground, at the same time.

This Drop Test will help to ensure that all the Bolts, Screws and gaps all reach full alignment status.

Test again for evenness on a Level Surface.

If no wobbles are found, proceed to tighten all the Bolts and Screws.

Note: When tightening the Bolts or Screws, tighten sequentially. Do not tighten any Bolt or Screw fully and then move towards the next one. This could cause the frame to warp.

If there are still wobbles, loosen the Bolts and Screws and execute this same drop test.

Note: If the Stool is not stable, it could lead to damage to the product.

Step 8

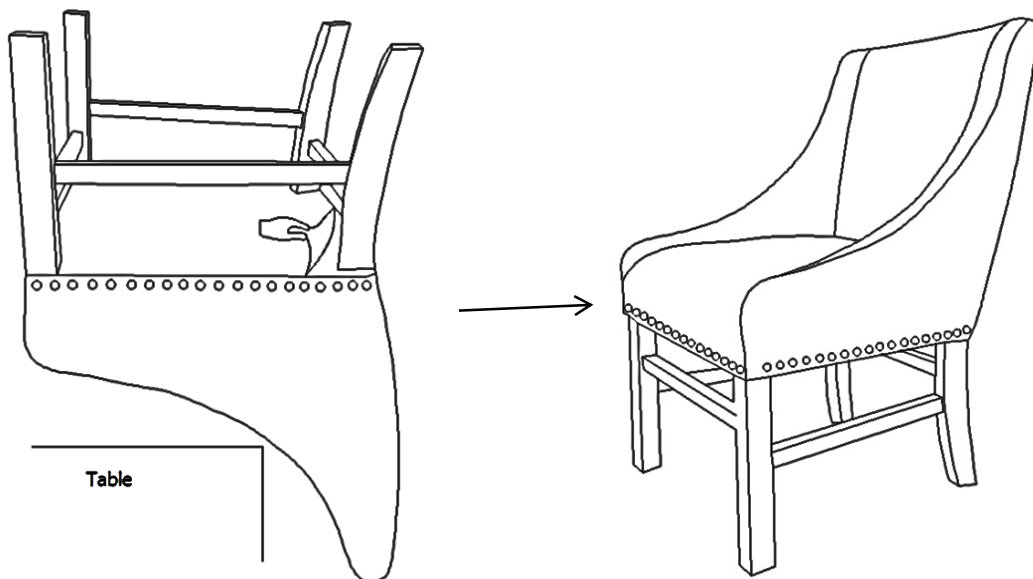

Place the Seat Base Cover back as shown in picture.

Smooth down with your hand on the Magic Tape on all 4 sides at the edge of the seat.











Make sure all parts are connected and securely locked into position.

Then turn it the right side up.

Your Bar Stool is ready for use.

This Bar Stool can only be used on a flat, level surface.

Care & Maintenance

-  Do not put hot items directly on furniture surface
 -  Do not clean furniture with harsh cleansers or polish.
 -  Do not place furniture under direct sunlight.
 -  Do not place furniture near heating or cooling vents.
 -  Do not write on furniture without a padded barrier to protect the surface.
 -  Do not place furniture outside . For indoor use only .
 -  Not for commercial use. For residential use only .
 -  Stains may be removed with mild soap solution and damp cloth.
 -  Children should not climb or jump on the furniture.
-
-  Dust and pick-up spills using a clean, non-colored, lint-free cloth .