

Assembly Instructions

Caution : You must read this before you proceed.

BENCH

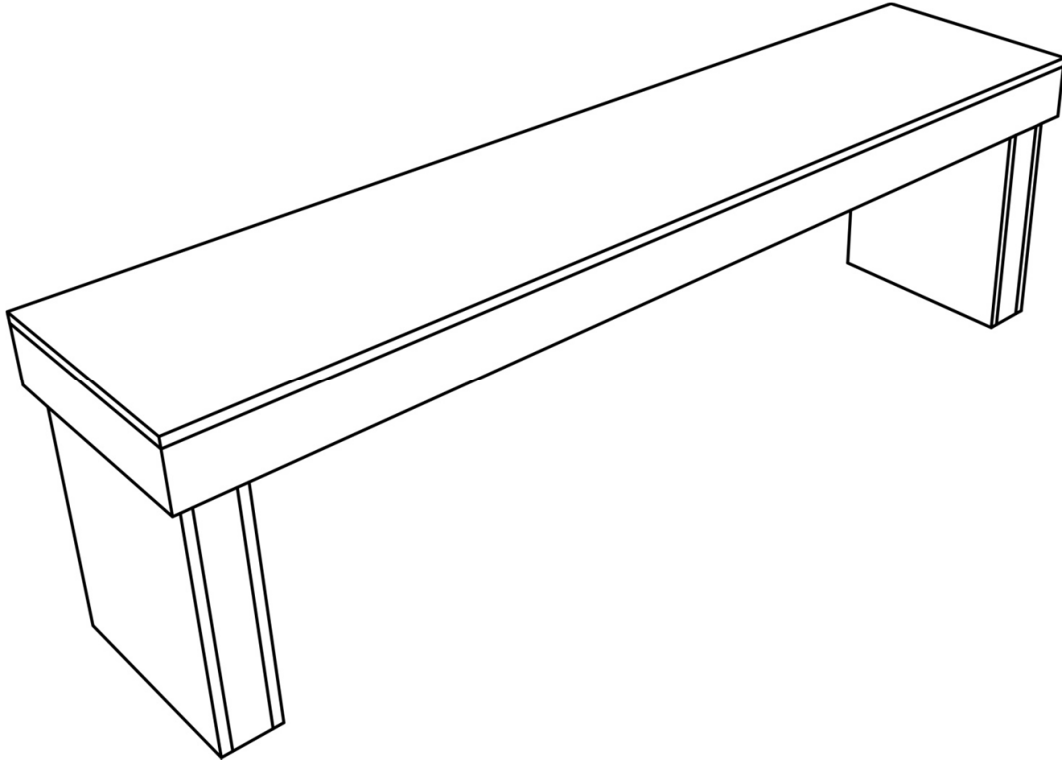





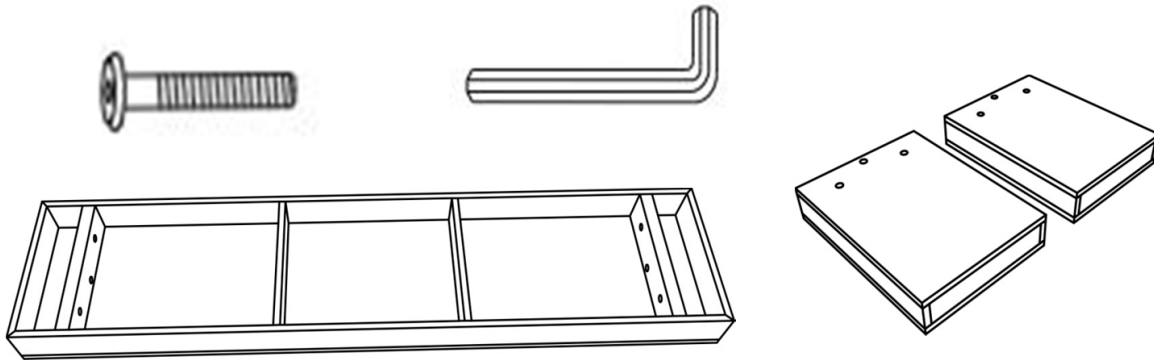

CAUTION : This Bench is NOT a TOY. Keep your child / children at bay in the process of assembly.

For turning / flipping the Bench and to prevent damage to the Bench, 02 persons may be needed to execute this action.

Assembly Preparation

Before Beginning Assembly:



-  • Read instructions, cover to cover-
-  • Have 2 adults on hand for assembly-
-  • Do not assemble on flooring or carpet-
-  • Assemble on a clean non-marring surface (packing foam)-
-  • Save all packaging until finished-

Parts List

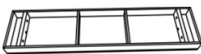
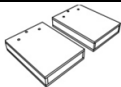
NO.	Picture	Description	QTY
A		Bench Seat	1
B		Leg Panels	2

Hardware

C		Bolts (M8x50mm)	7
D		Allen Key	1

Assembly Steps

Step 1

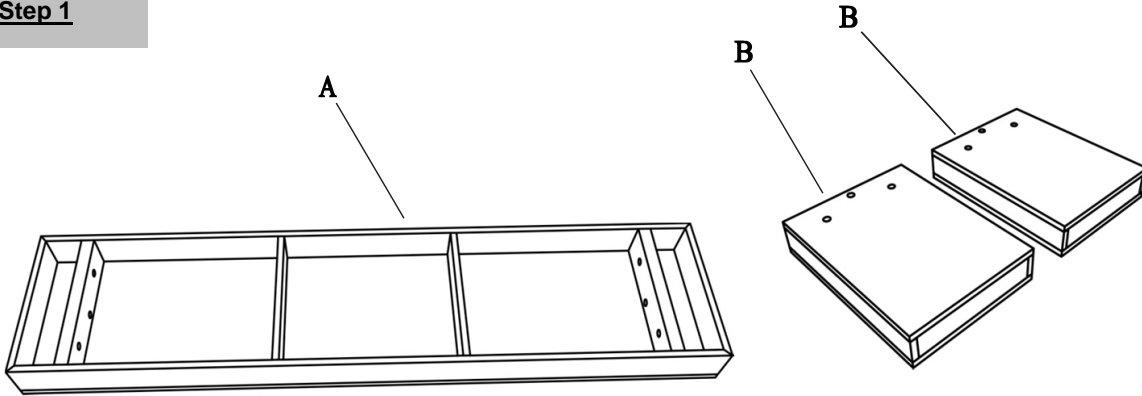

Unpack the pack of hardware that is packed inside the Bench.
Place the Bench Seat (A) upside down, onto a clean soft surface to avoid any scratch or damage to the product.
To avoid any damage to the Bench Seat (A) and Leg Frames (B), exercise caution in the process of turning the Bench over.

Step 2

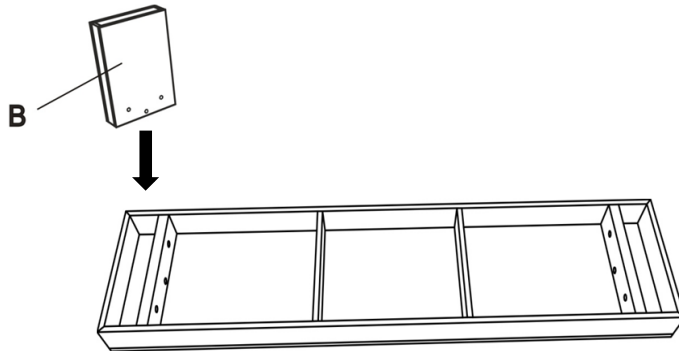

Insert the Leg Panel (B) to the Bench Seat (A) housing as denoted by BOLD ARROW, as pictured above.
Repeat the same process with the other Leg Panel (B).

Step 3

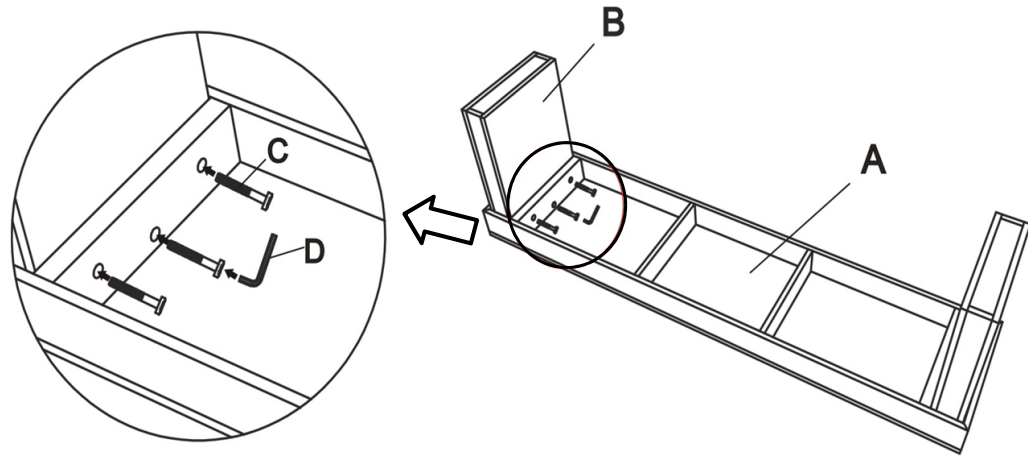

Align and secure Leg Frame (B) to the Bench Seat (A) by using 3 Allen Bolts (C) and Allen Key (D) as shown in the round picture

Repeat the same process for the other Leg Frame (B)

To ensure there is NO WOBBLES to the feet, **DO NOT overtighten the Bolts.**

Each Bolt is to be driven in sequentially and where necessary, the Bench may be turned to check for evenness.

It may be necessary to execute this check twice to ensure that all 02 Leg Panels are affixed to the Bench with no wobbles.

Step 4

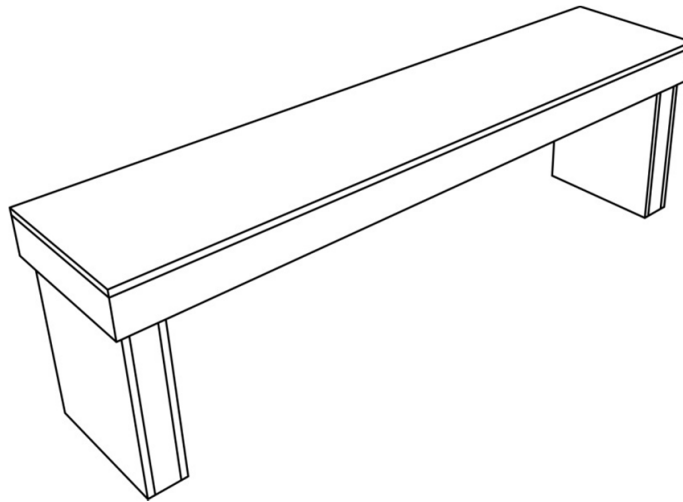



















Turn the Bench upright carefully.

Proceed to fully tighten all Bolts (C) with using the Allen Key (D), in a sequential manner. Ensure that all Bolts are securely tightened.

The Bench is ready to use now.

Care & Maintenance

-   • Do not put hot items directly on furniture surface.
 -   • Do not clean furniture with harsh cleansers or polish.
 -   • Do not place furniture under direct sunlight.
 -   • Do not place furniture near heating or cooling vents.
 -   • Do not write on furniture without a padded barrier to protect the surface.
 -   • Do not place furniture outside. For indoor use only.
 -   • Not for commercial use. For residential use only.
 -   • Stains may be removed with mild soap solution and damp cloth.
-
-   • Dust and pick-up spills using a clean, non-colored, lint-free cloth.