

ASSEMBLY INSTRUCTIONS

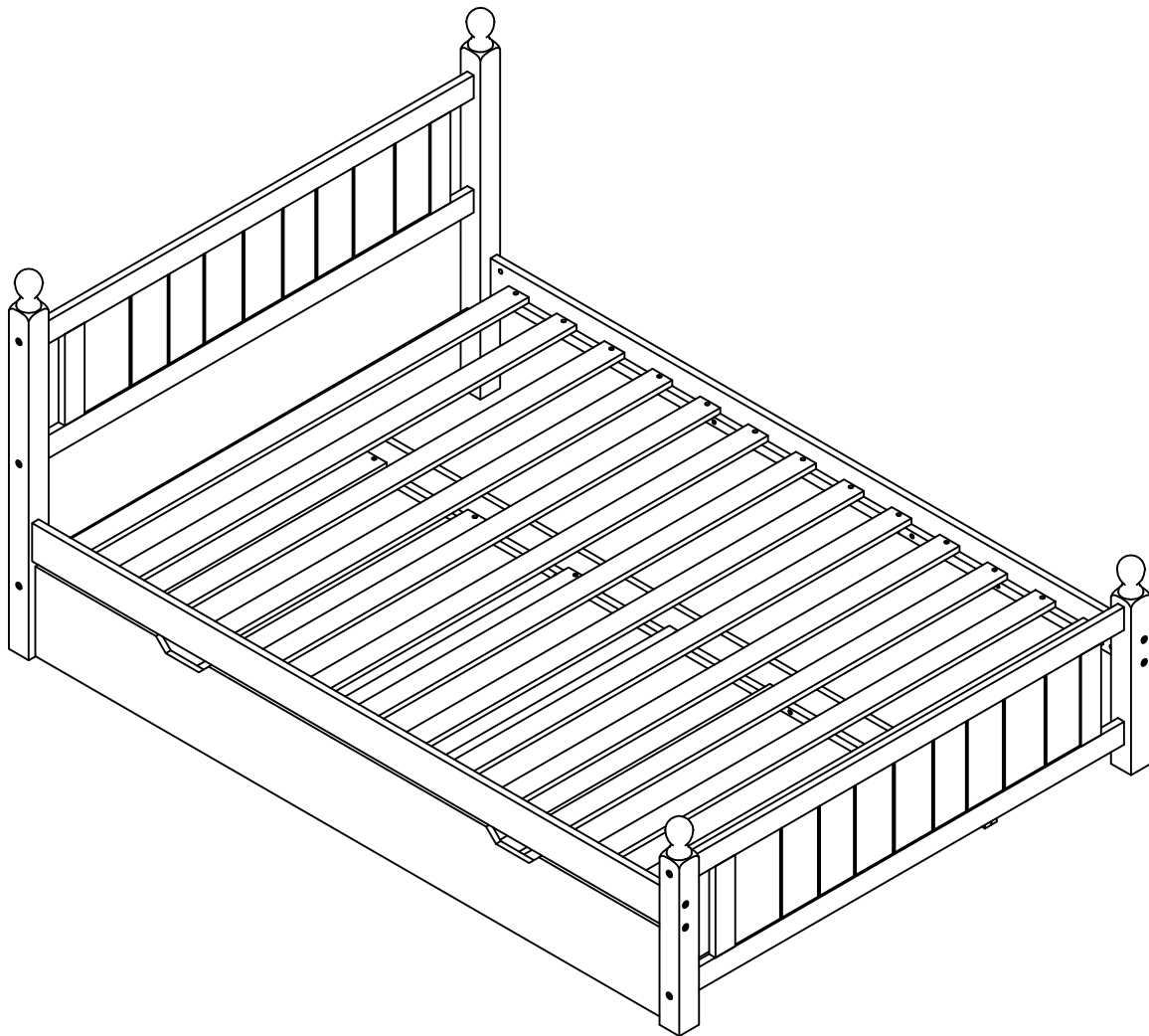

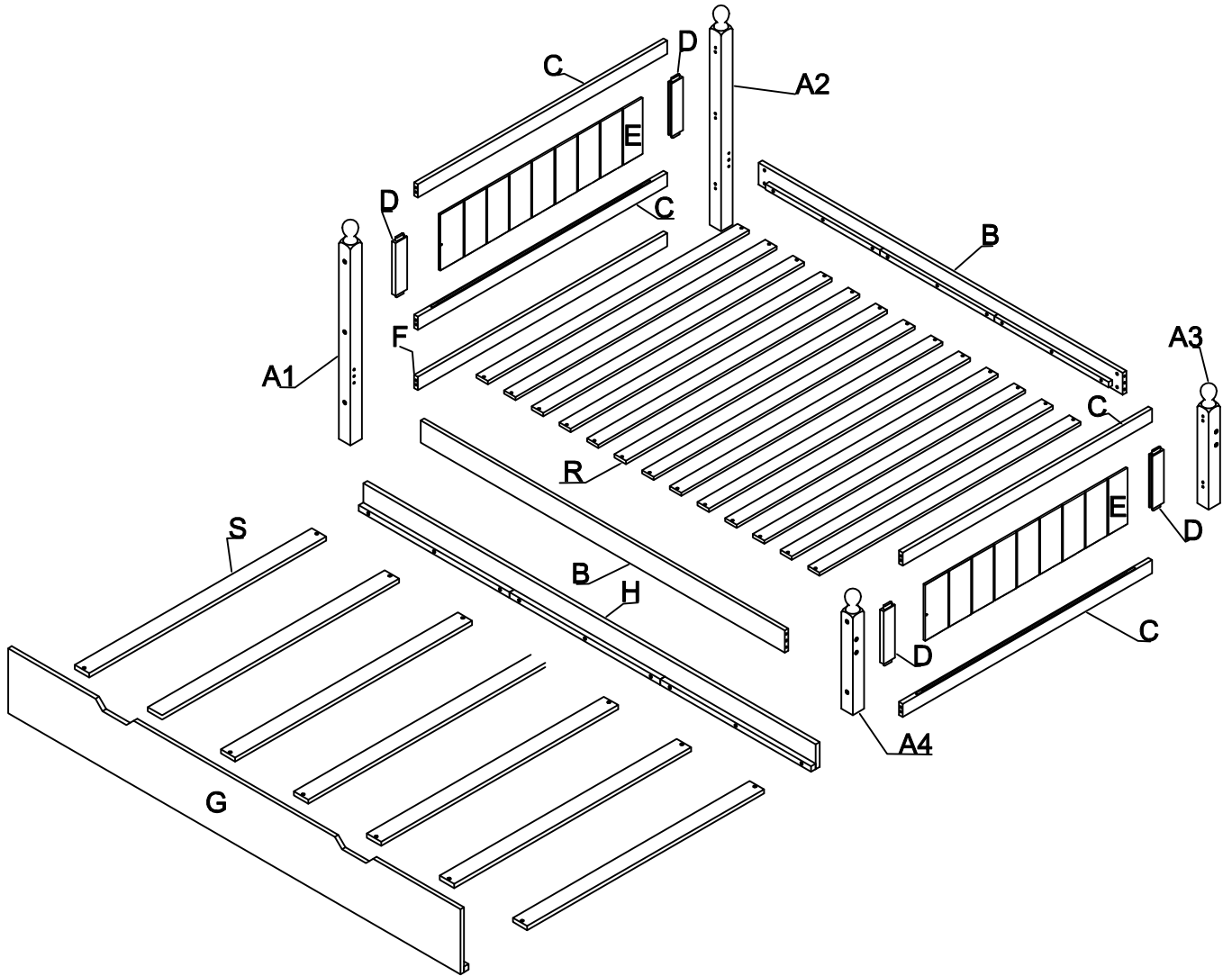

ITEM CODE: WF318554







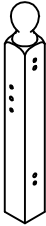
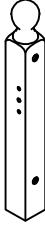
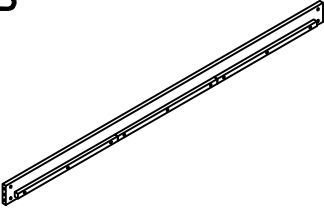
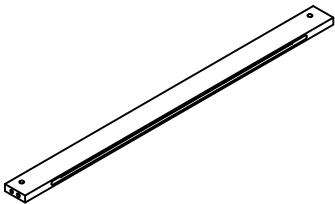

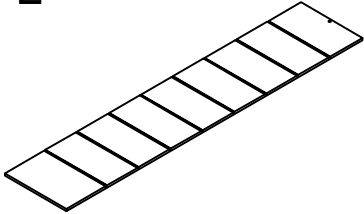
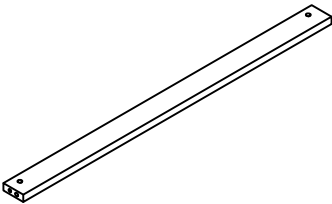
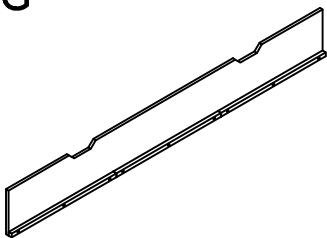
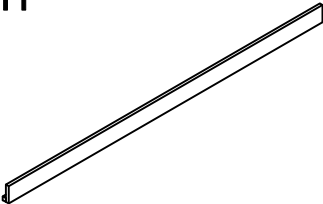
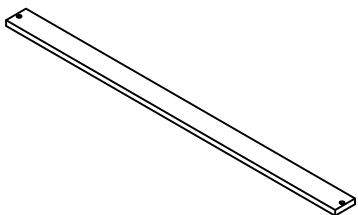
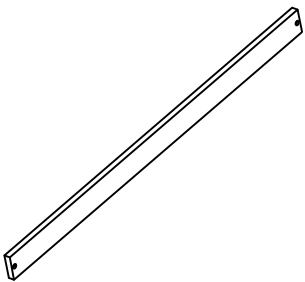
DETAIL VIEW

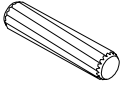

BOX: WF318554

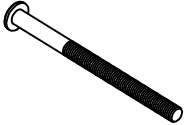
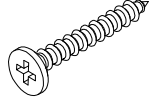
<p>A1</p>  <p>Left Fore Leg - (1pc)</p>	<p>A2</p>  <p>Left Hind Leg - (1pc)</p>	<p>A3</p>  <p>Right Hind Leg - (1pc)</p>	<p>A4</p>  <p>Right Fore Leg - (1pc)</p>
<p>B</p>  <p>Shoulder Bed - (2pcs)</p>	<p>C</p>  <p>Frame Horizontal Bar - (4pcs)</p>	<p>D</p>  <p>Vertical Bar - (4pcs)</p>	<p>E</p>  <p>Hip Plank - (2pcs)</p>
<p>F</p>  <p>Horizontal Below - (1pc)</p>	<p>G</p>  <p>Front trundle - (1pcs)</p>	<p>H</p>  <p>Back trundle - (1pcs)</p>	<p>R</p>  <p>Slats - (13pcs)</p>
<p>S</p>  <p>Slats - (7pcs)</p>			

HARDWARE LIST: WF318554

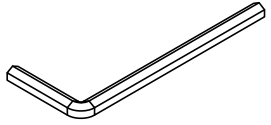
<p>1</p>  <p>Wood dowel Ø8 * 30 - 14pcs</p>	<p>2</p>  <p>Horizontal - Hold bolts Ø1/4" - 18pcs</p>	<p>3</p>  <p>Hex - Head bolts Ø1/4" * 110 - 18pcs</p>	<p>4</p>  <p>Wood crews M4 * 25 - 40pcs</p>
<p>5</p>  <p>Round wood crews M3.5 * 15 - 16pcs</p>	<p>6</p>  <p>L - Bracket - 4pcs</p>	<p>7</p>  <p>Wheel 4pcs</p>	<p>8</p>  <p>Allen key K4 - 1pcs</p>

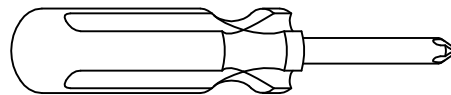

Assembly Tools Required (Not Included)

STEP 1

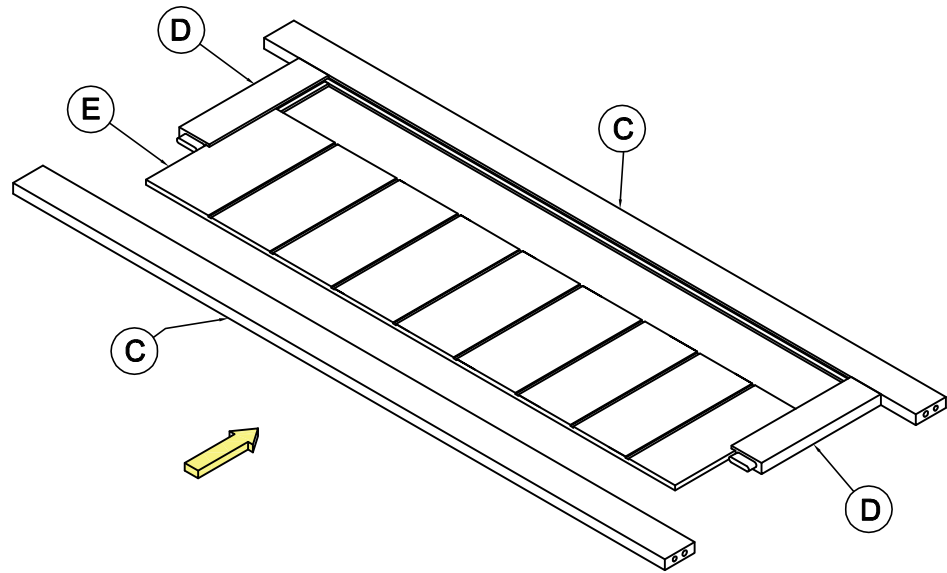

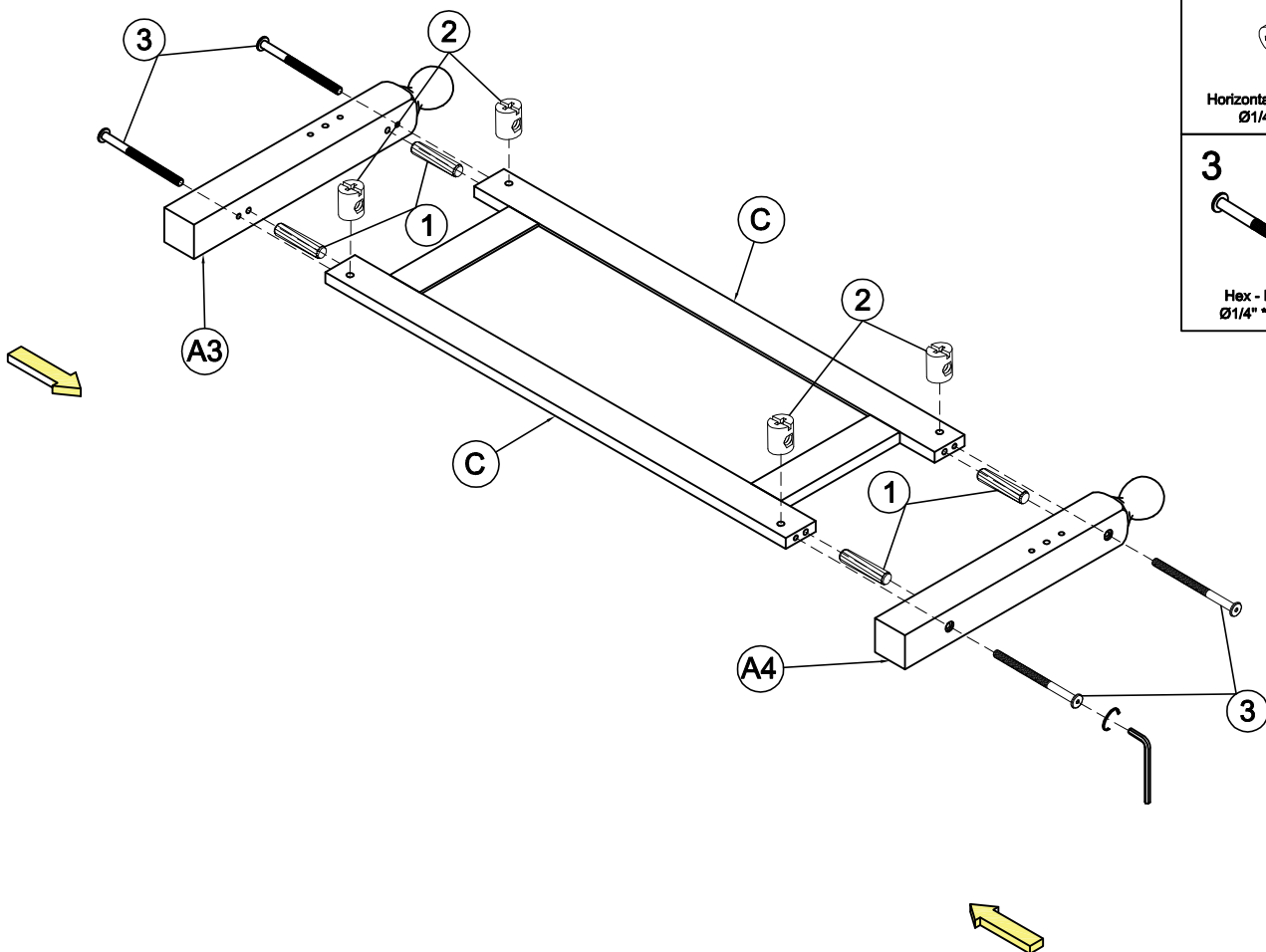

X2

STEP 2



1

Wood dowel
Ø8 * 30 - 4pcs

2

Horizontal - Hold bolts
Ø1/4" - 4pcs

3

Hex - Head bolts
Ø1/4" * 110 - 4pcs

STEP 3

1



Wood dowel
Ø8 * 30 - 6pcs

2



Horizontal - Hold bolts
Ø1/4" - 6pcs

3



Hex - Head bolts
Ø1/4" * 110 - 6pcs

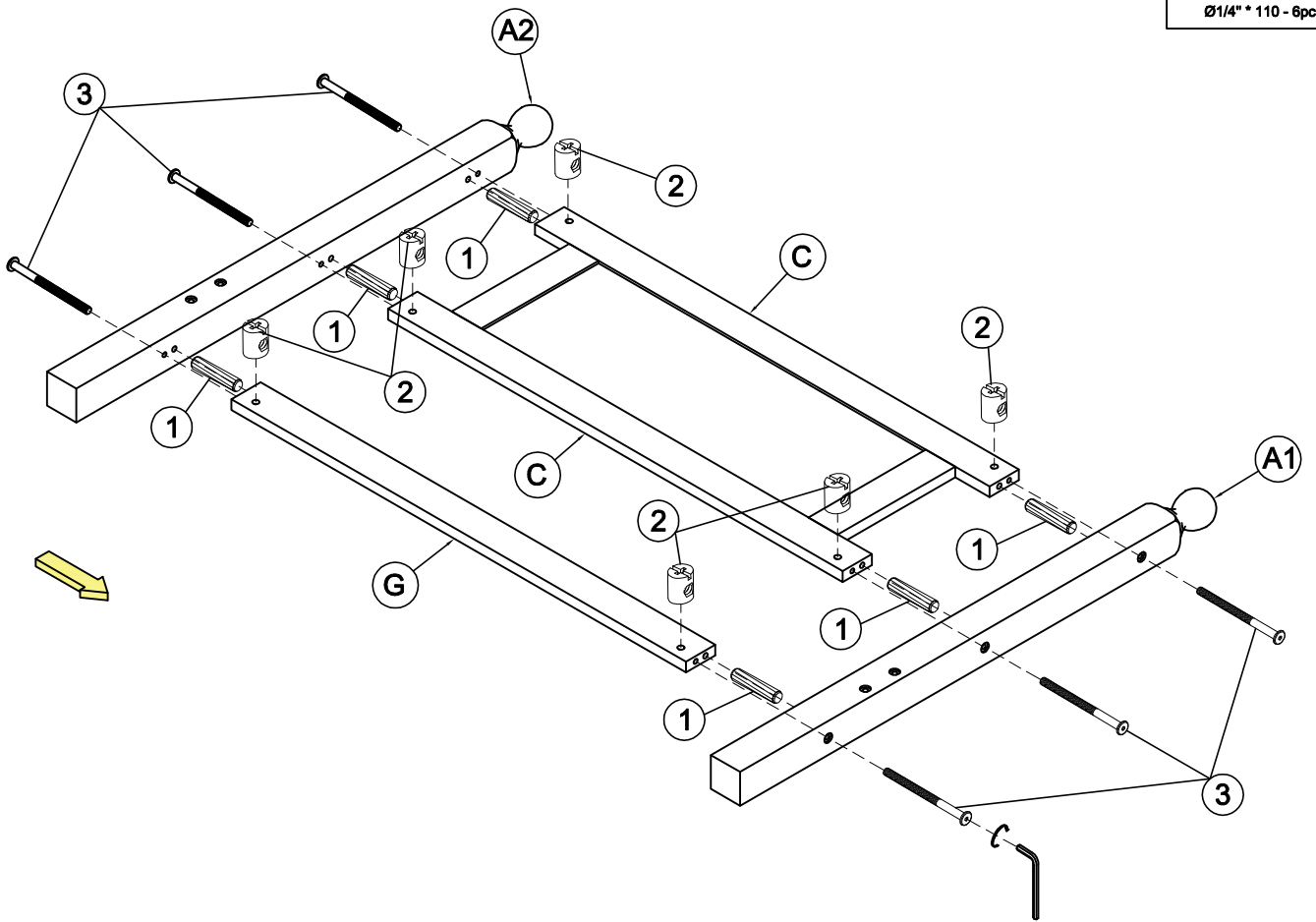

STEP 4

1



Wood dowel
Ø8 * 30 - 4pcs

2



Horizontal - Hold bolts
Ø1/4" - 8pcs

3



Hex - Head bolts
Ø1/4" * 110 - 8pcs

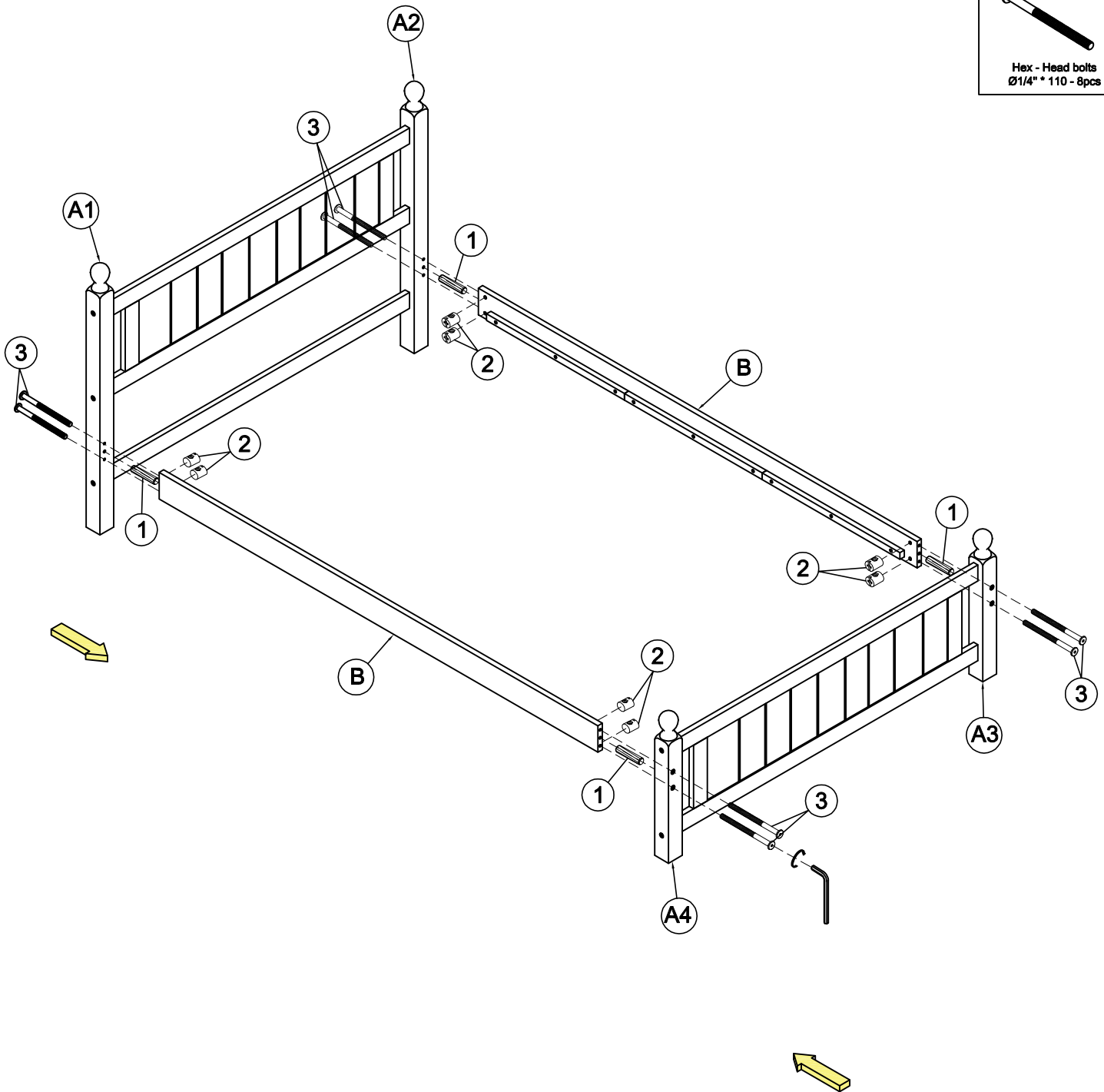

STEP 5

4

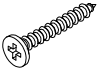

Wood crews
M4 * 25 - 28pcs

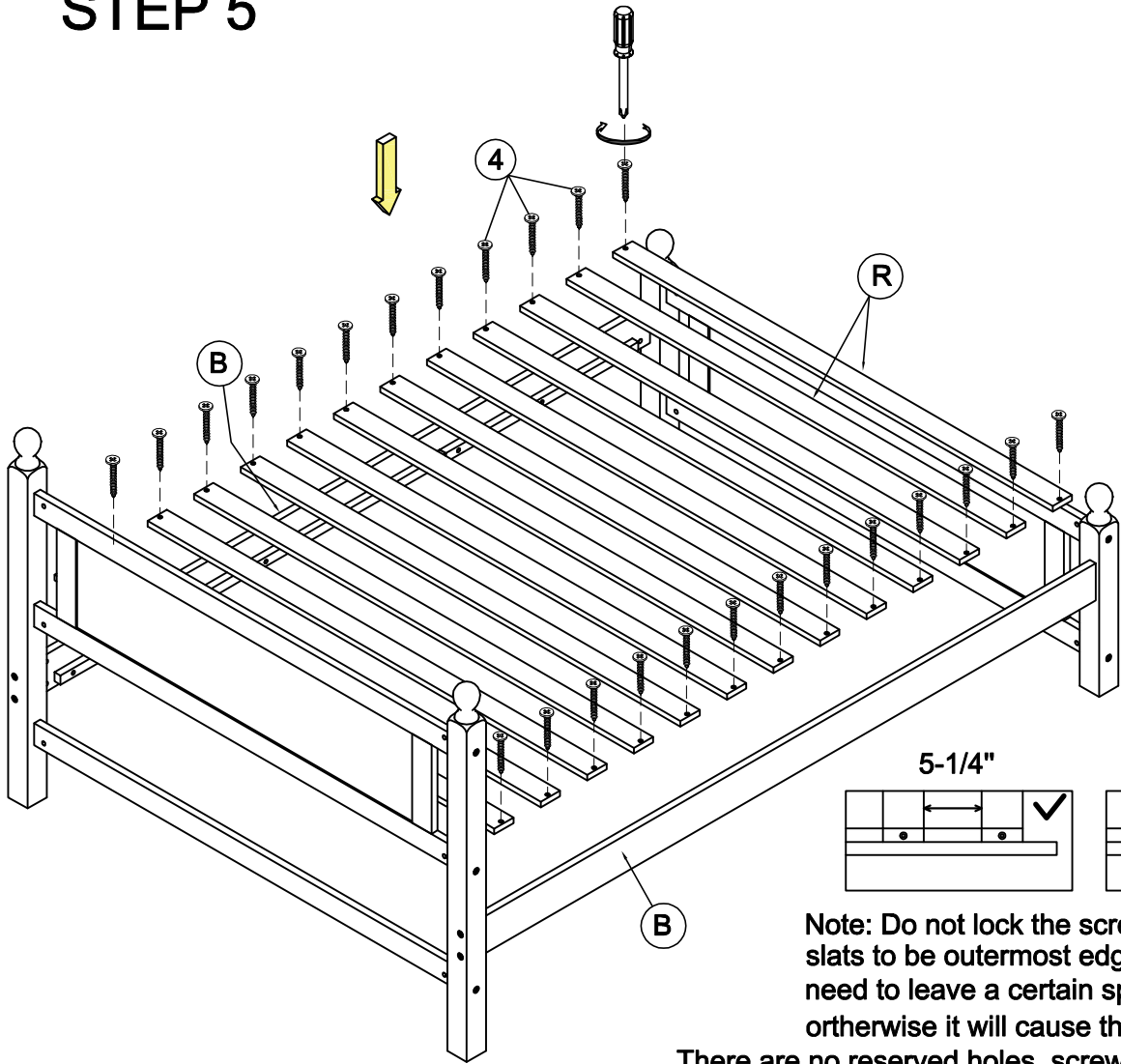

5-1/4"

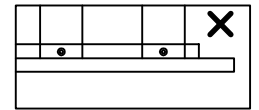
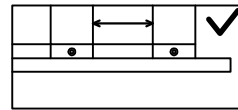

Note: Do not lock the screws of the bed slats to be outermost edge the bed slats, you need to leave a certain space at the edges, otherwise it will cause the board to break

There are no reserved holes, screws can be drilled in

STEP 6

4

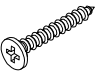

Wood crews
M4 * 25 - 14pcs

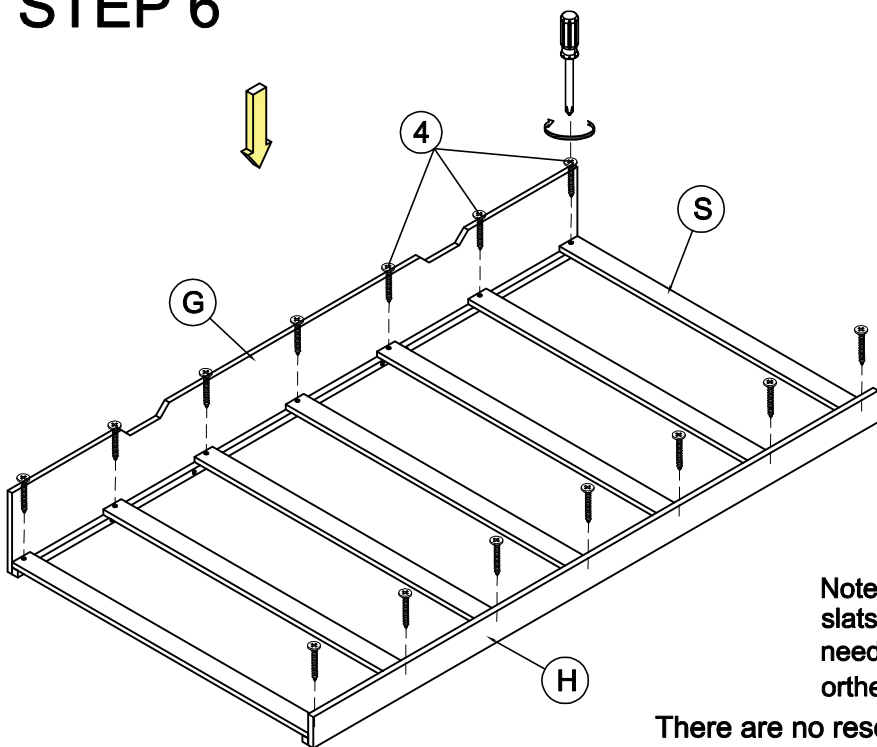

8-1/4"

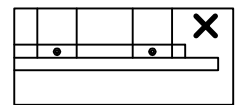
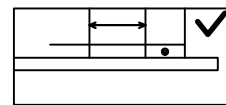

Note: Do not lock the screws of the bed slats to be outermost edge the bed slats, you need to leave a certain space at the edges, otherwise it will cause the board to break

There are no reserved holes, screws can be drilled in

STEP 7

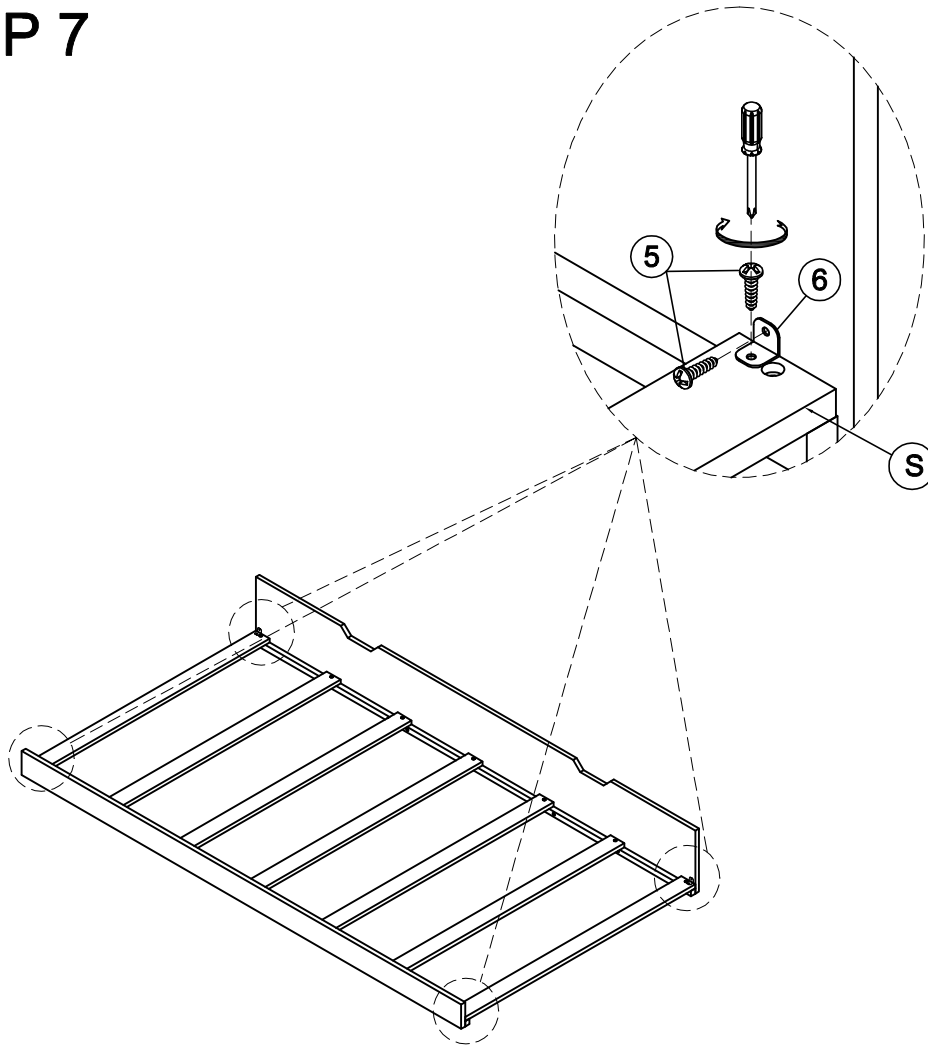

5



Round wood crews
M3.5 * 15 - 8pcs

6



L - Bracket - 4pcs

STEP 8

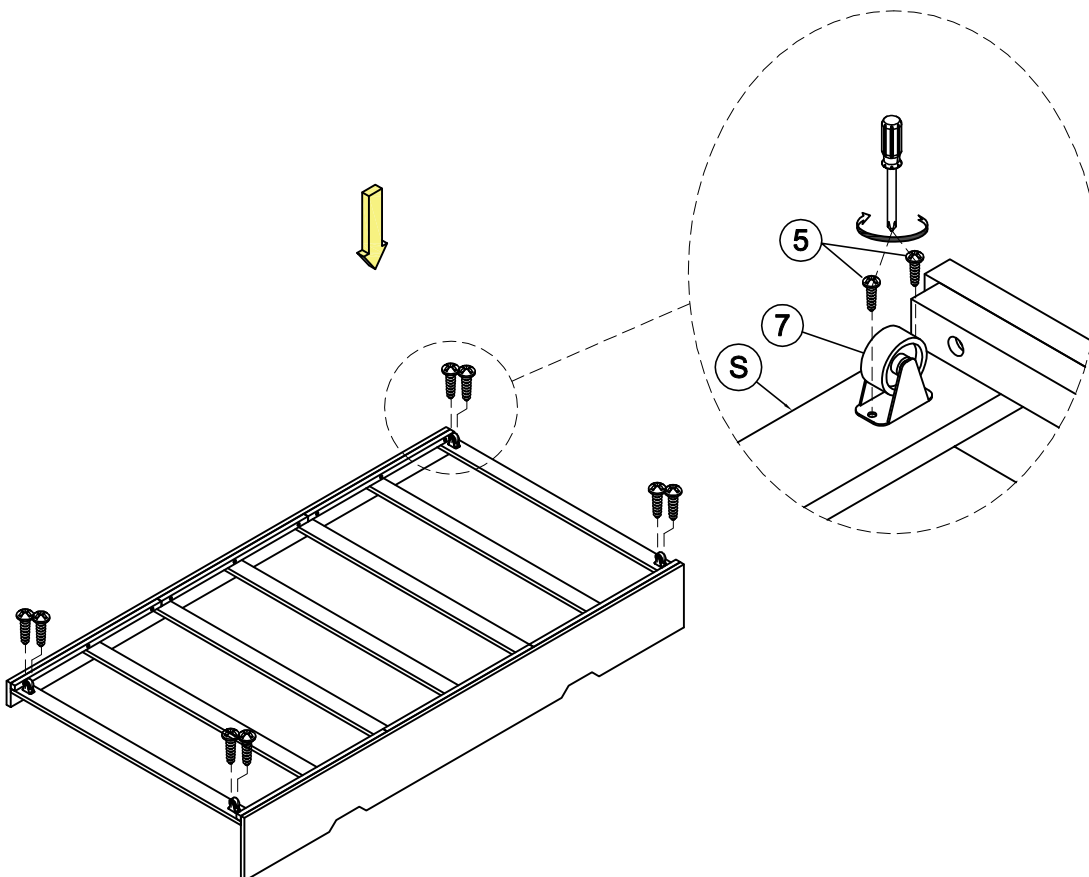

7



Wheel
4pcs

5



Round wood crews
M3.5 * 15 - 8pcs

STEP 9



COMPLETED

