

**WF318060**  
**WF318061**

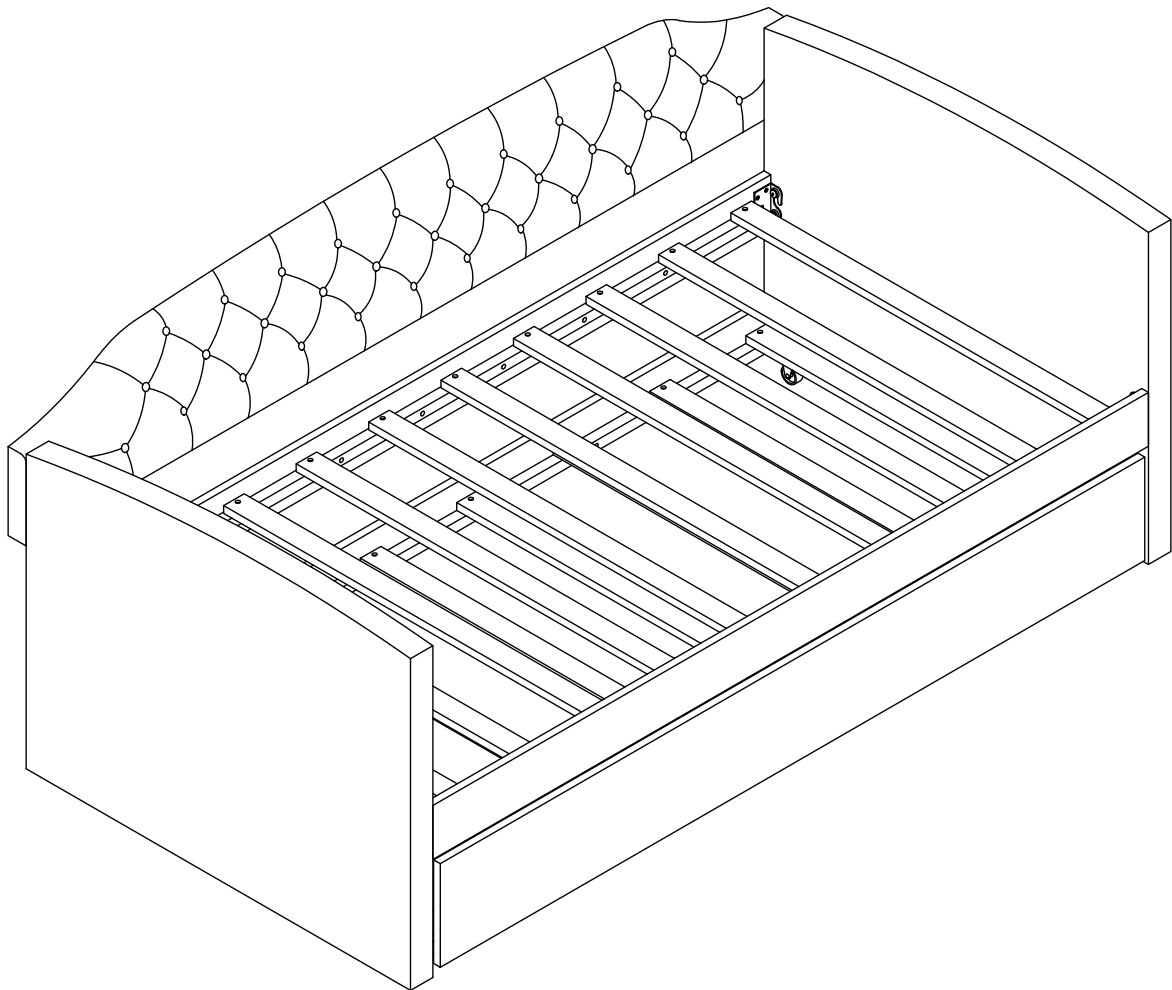

# **ASSEMBLY INSTRUCTIONS**

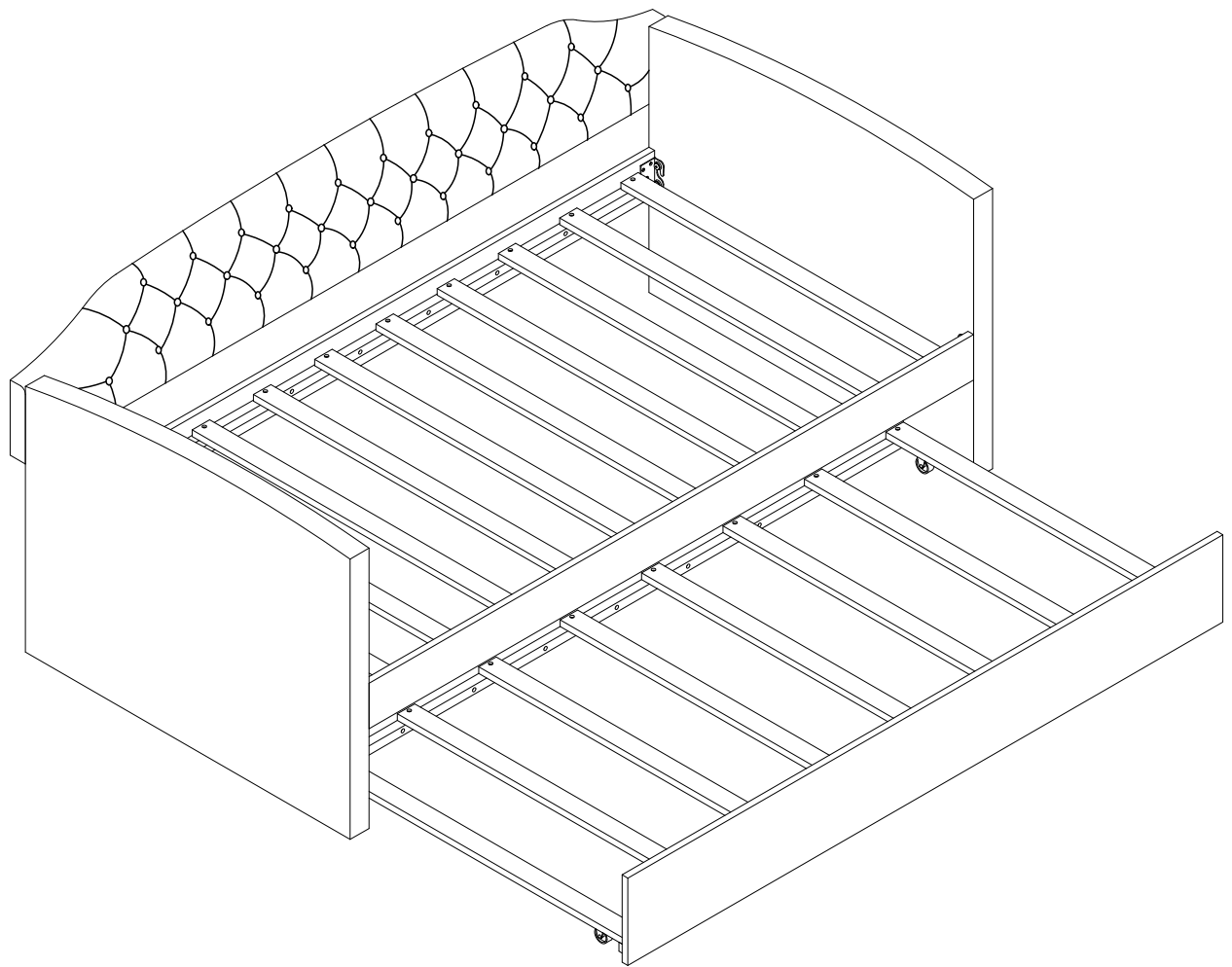

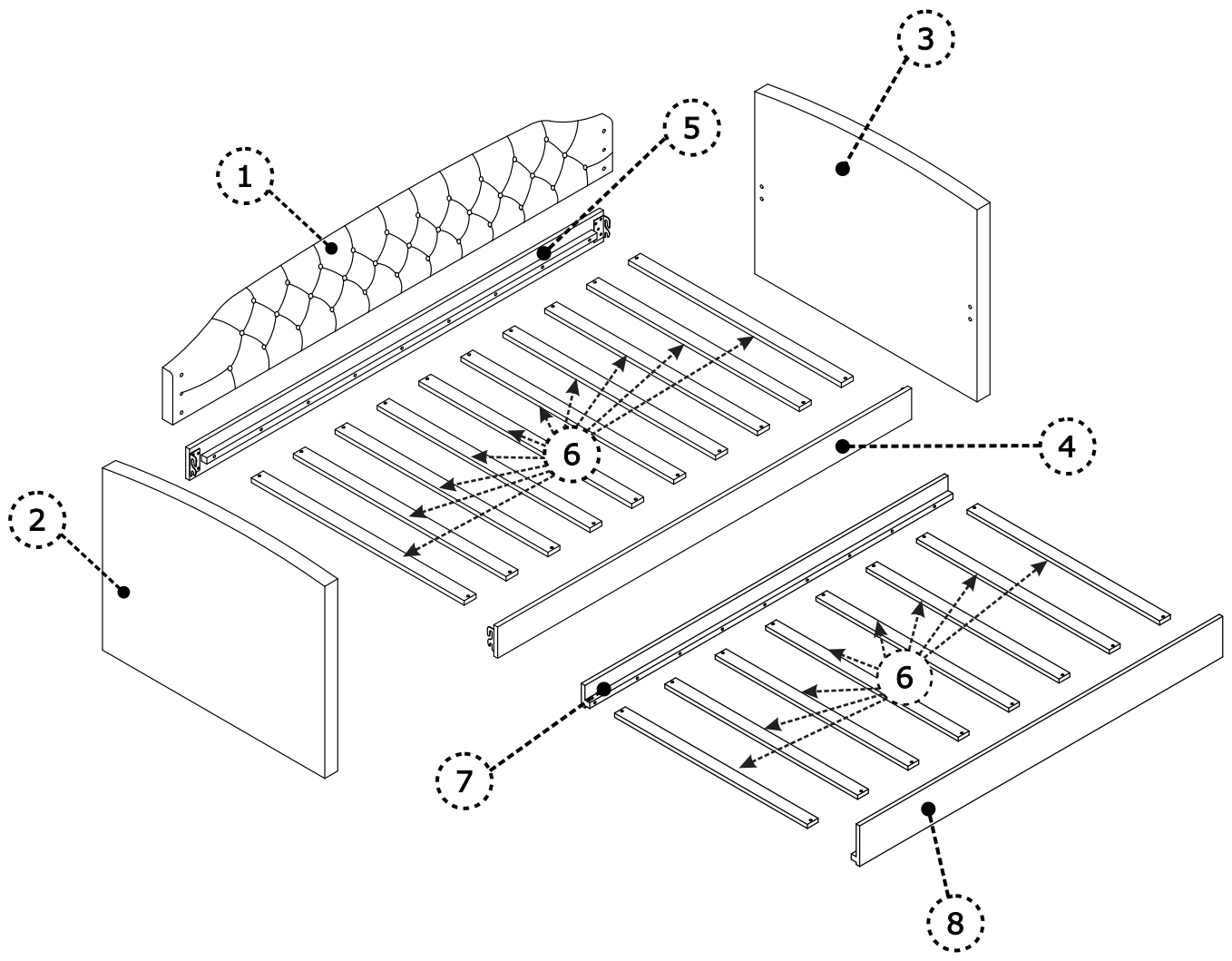

# PARTS

Check that you've received  
all parts listed below.

**BOX: 1/2**  
**WF318060**

2 x 1

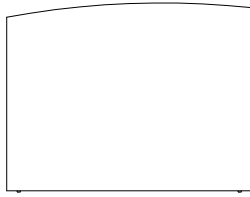

Side board Left

3 x 1

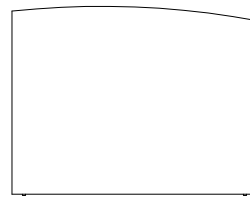

Side board Right

6 x 18

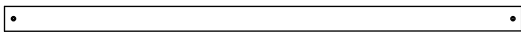

Slats

# PARTS

Check that you've received  
all parts listed below.

**BOX: 2/2**  
**WF318061**

1 x 1

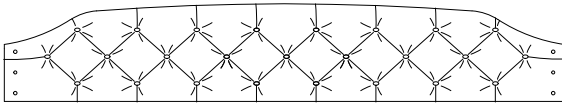

Head Board

4 x 1

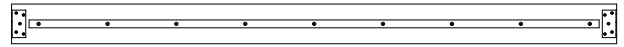

Front Rails

5 x 1

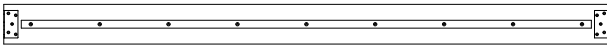

Back Rails

8 x 1

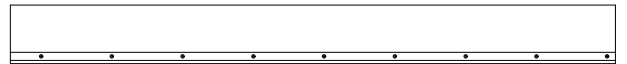

Front Rails (Trundle)

7 x 1

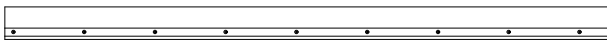

Back Rails (Trundle)









Hardware



# HARDWARE

Check that you've received all hardware listed below.

## Hardware List

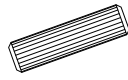
No.	OUTLOOK	DESC	QTY
(A)		<b>Bolts</b> 5/16"x30 mm	8
(B)		<b>Bolts</b> 5/16"x60 mm	4
(C)		<b>Plain washer</b> Ø19x1.5 mm	12
(D)		<b>Spring washer</b> Ø13x1 mm	12
(E)		<b>Allen key</b> 80x30x4 mm	1
(F)		<b>Screws</b> Ø4x15 mm	16
(G)		<b>Screws</b> Ø4x30 mm	36
(H)		<b>Wheel</b> 50x40x25 mm	4
(I)		<b>Dowel</b> Ø10 x 25 mm	2

# STEP 1

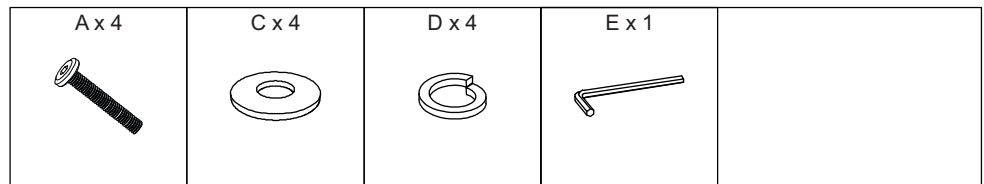

80%

X4

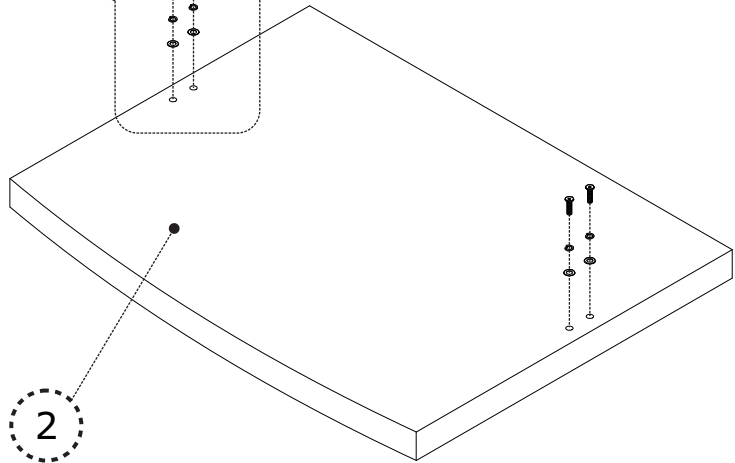
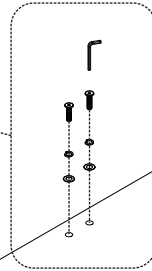
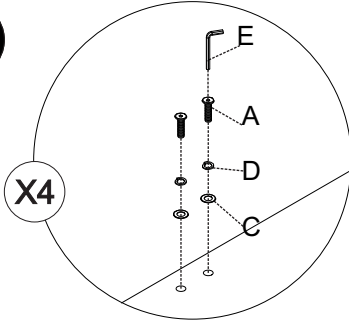

# STEP 2

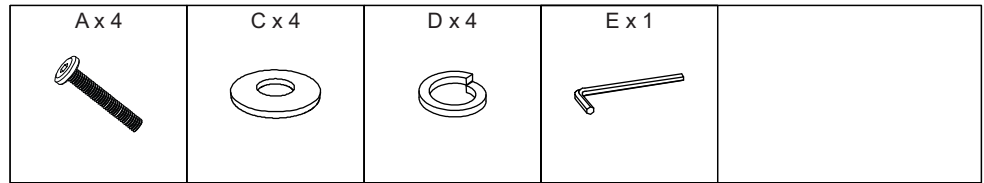

80%

X4

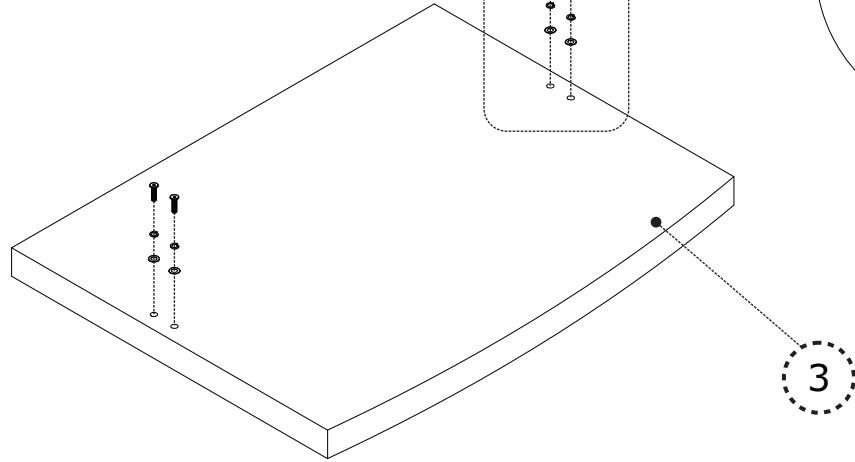
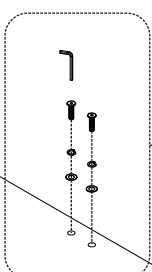
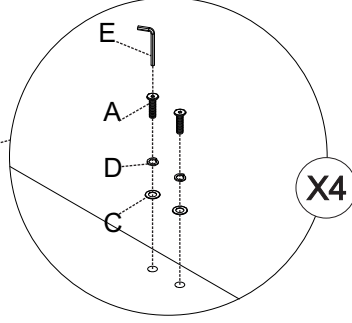

# STEP 3

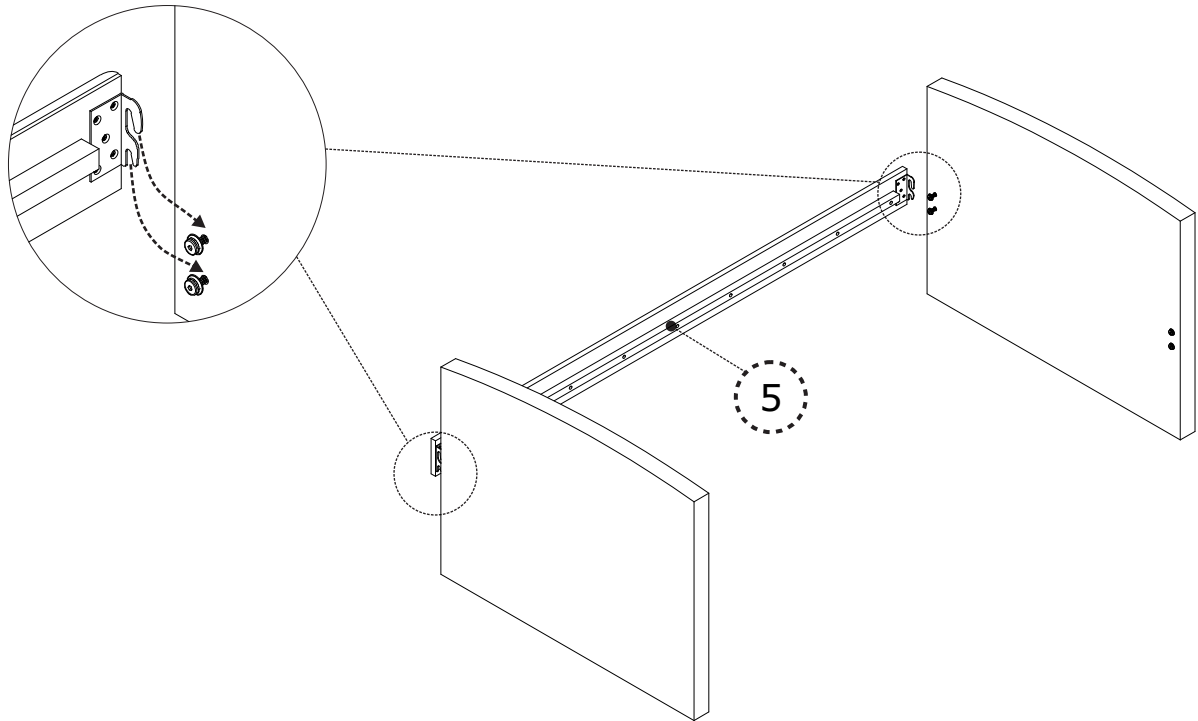
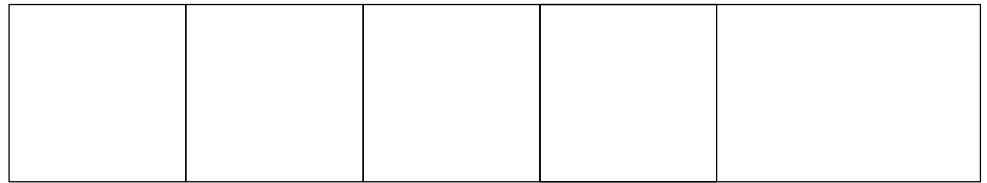

# STEP 4

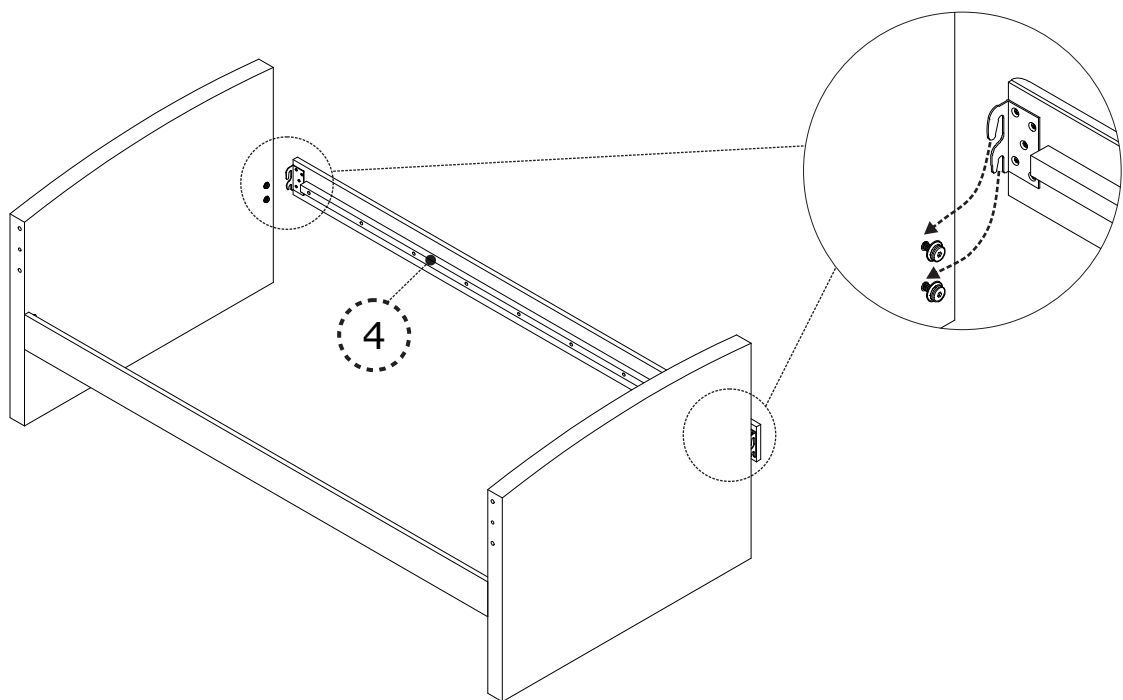
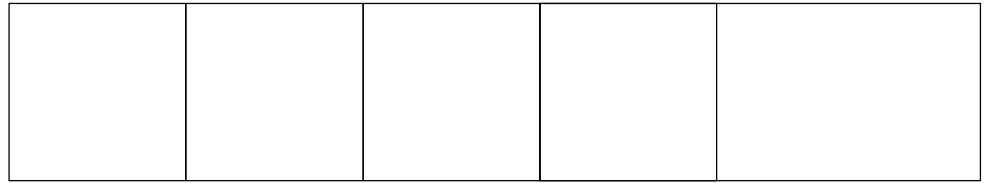





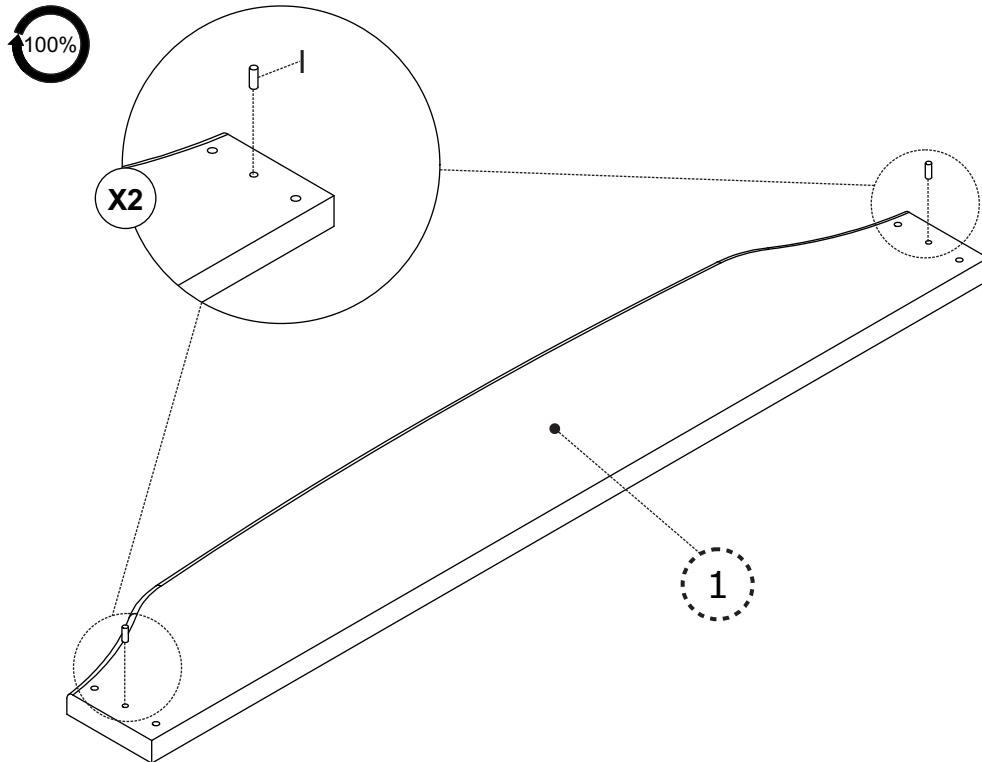
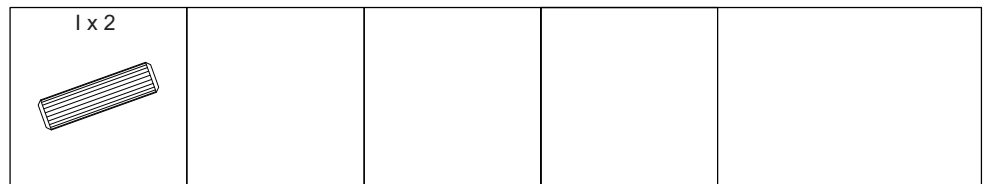

# STEP 5

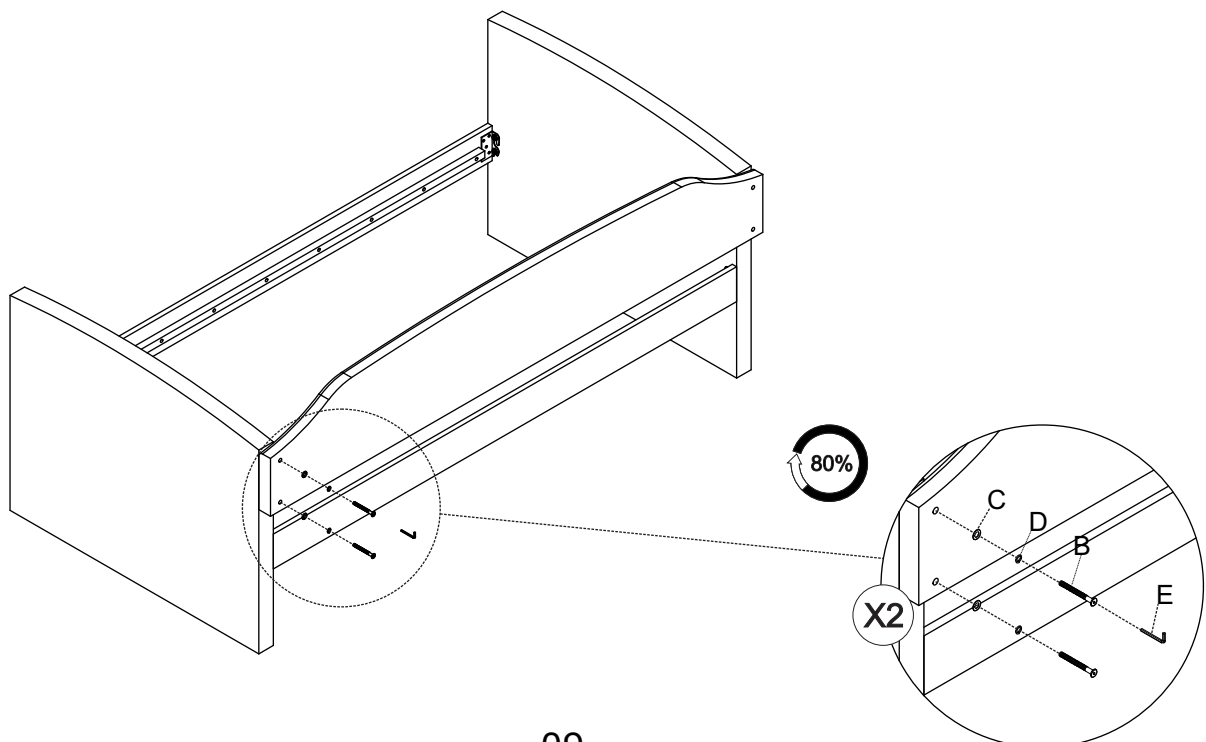
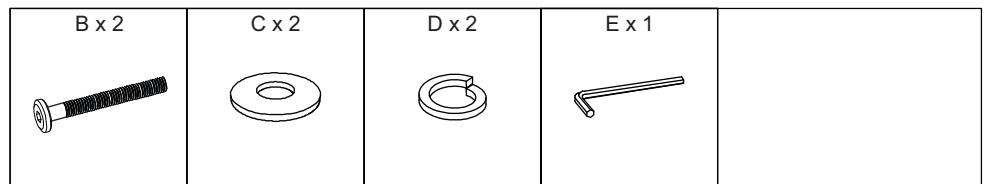

# STEP 6



# STEP 7

B x 2 	C x 2 	D x 2 	E x 1 	
--	--	--	--	--

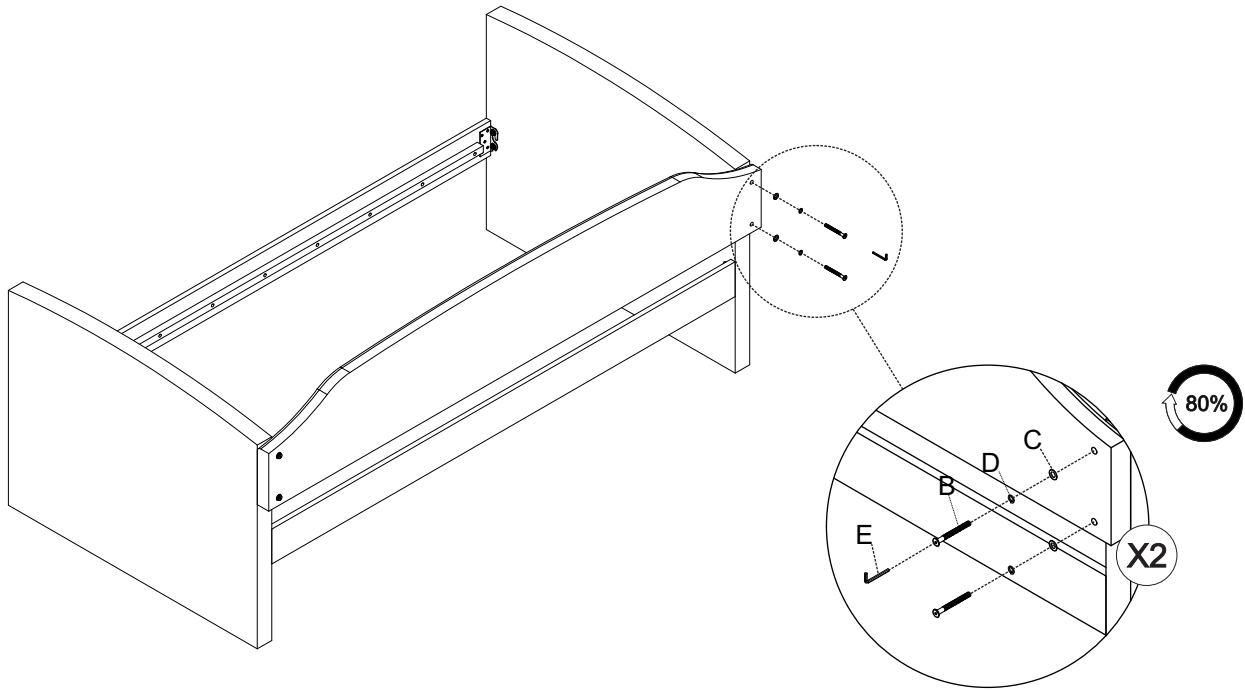

# STEP 8

E x 1 				
--	--	--	--	--

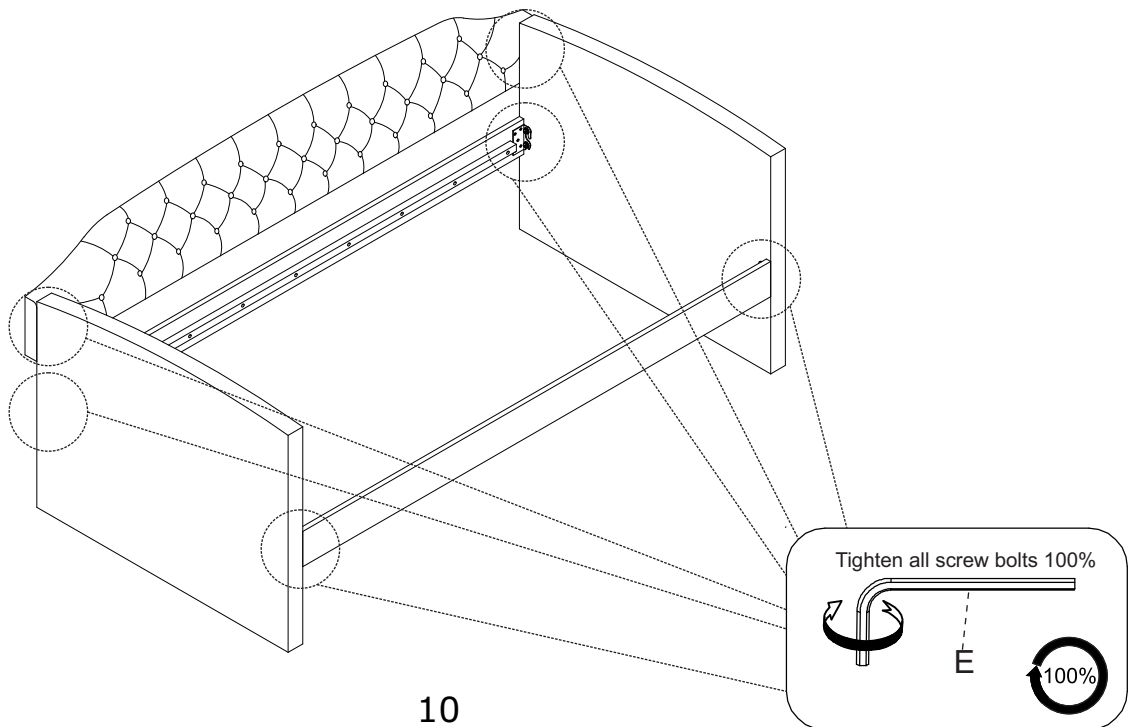

# STEP 9

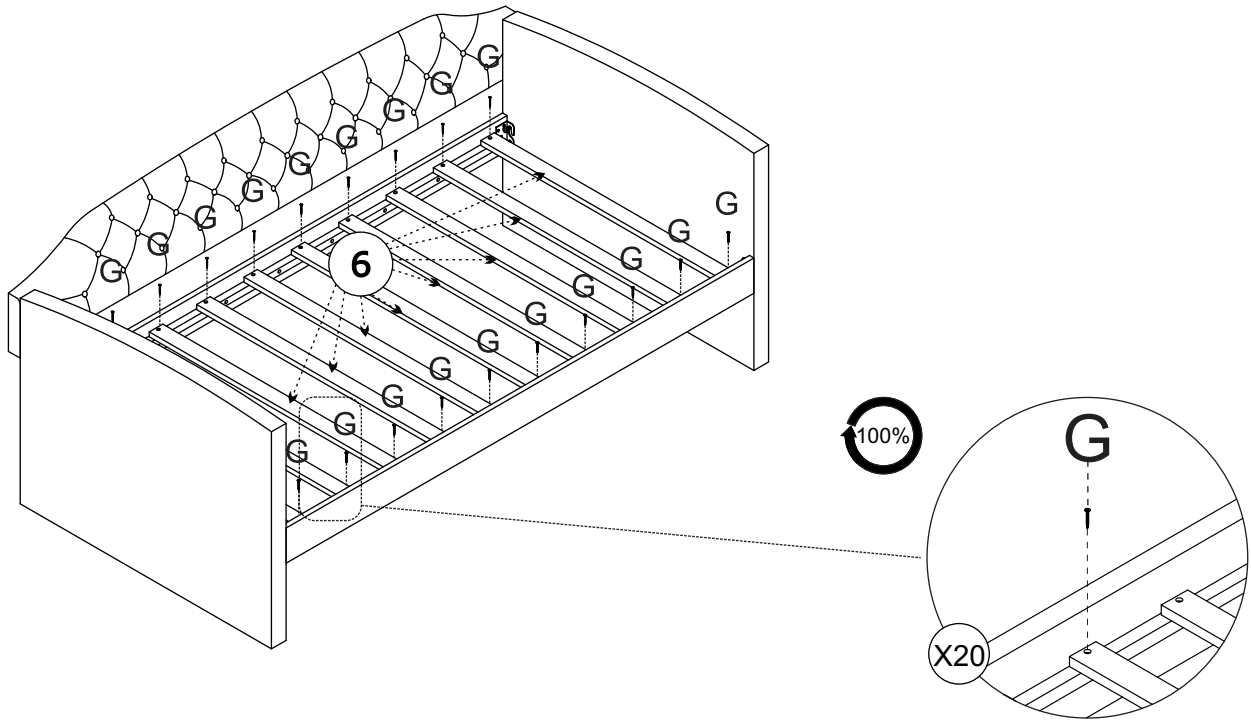
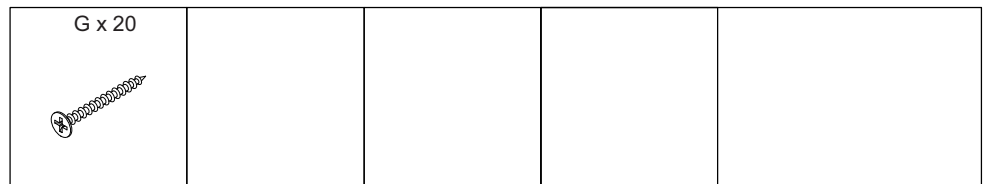

# STEP 10

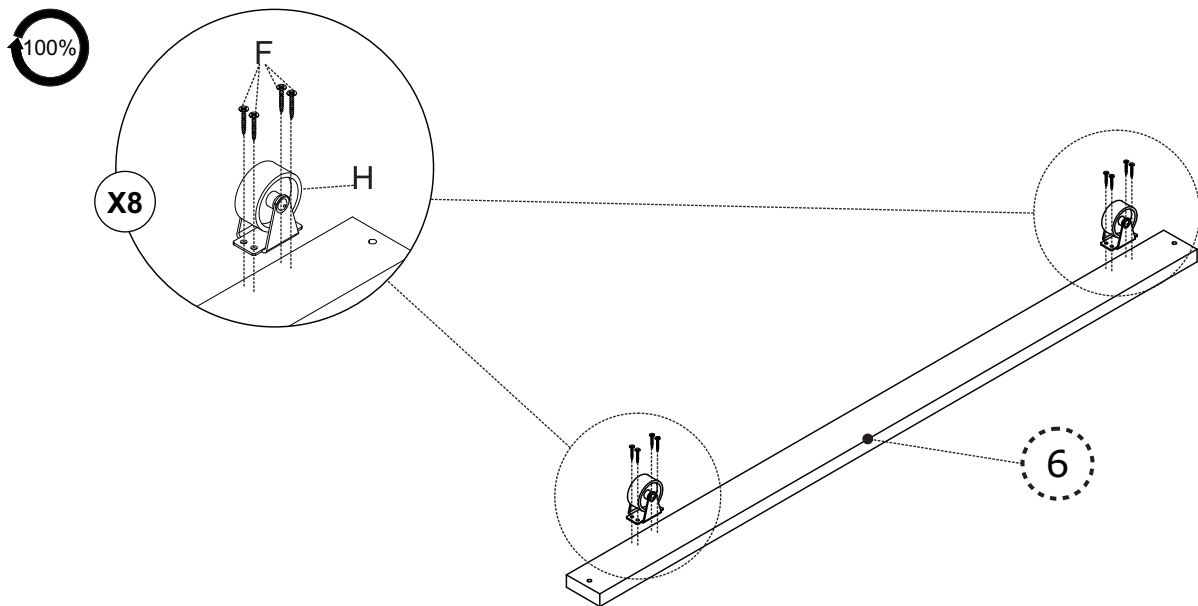
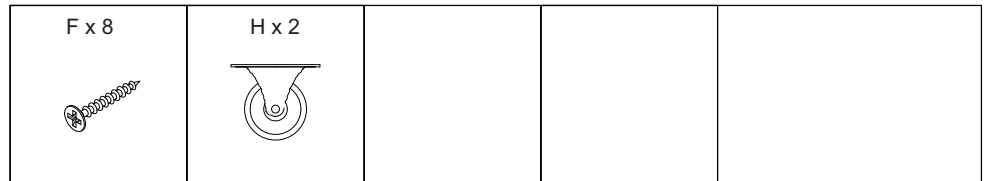

# STEP 11

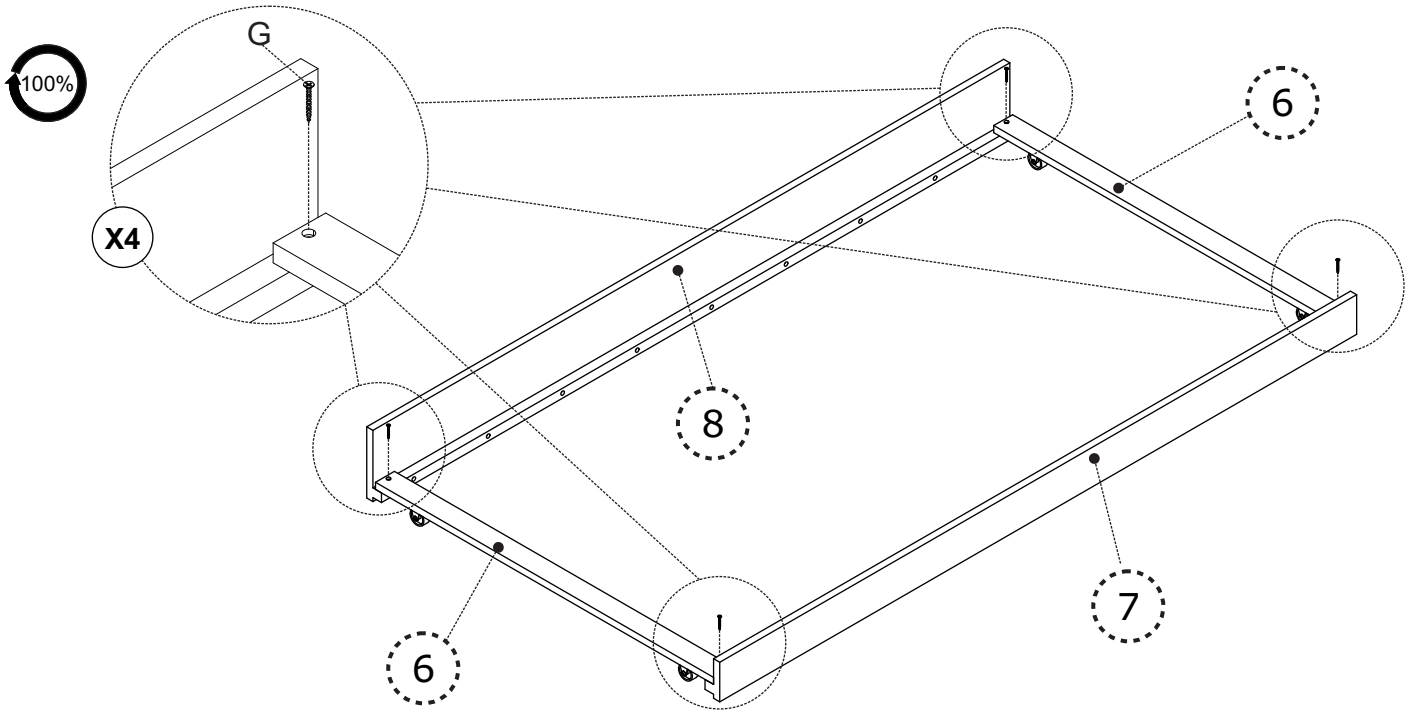
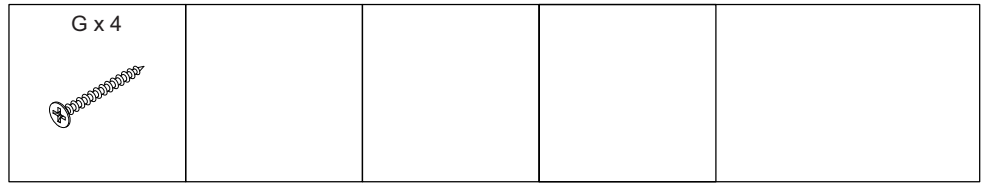

# STEP 12

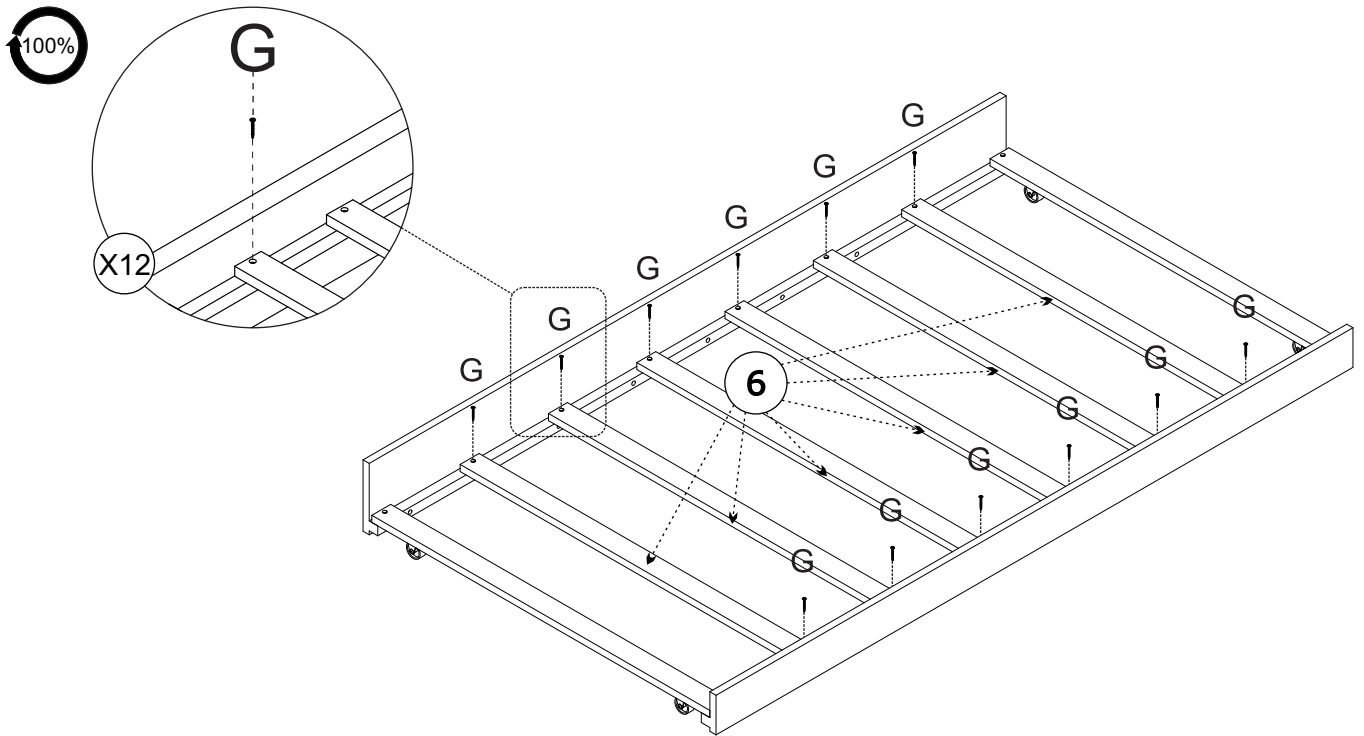
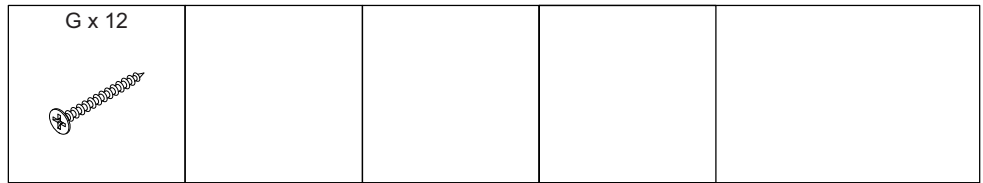

# STEP 13

