

# ASSEMBLY INSTRUCTIONS

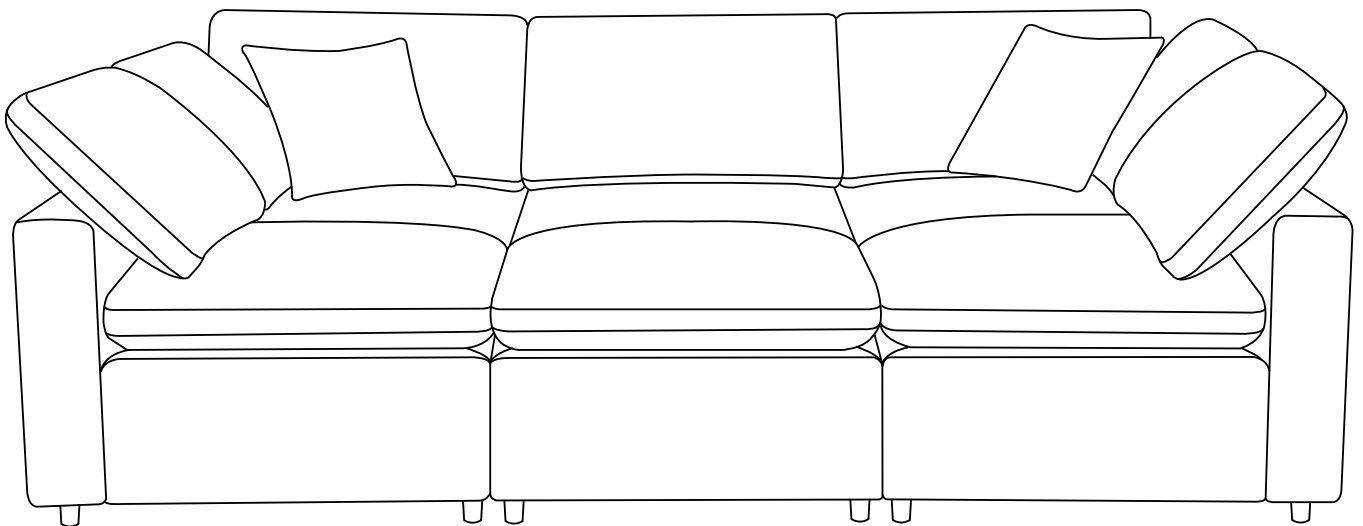









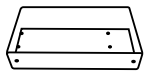
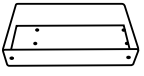
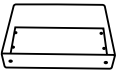
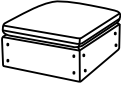

N723P171442/N723P171445/N723P171446/N723P171451/  
N723P171453/N723P171455/N723P171457

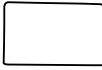

## Return & Warranty policy:

- We strive to offer the highest quality products, and we also try our best to satisfy each and every customer that orders from us with replacement parts/or service as needed.
- If the items is damaged or defective, please take photos as evidence for replacements and refunds.
- Please do not return to store, contact the seller if you have any troubles with this product.

# HARDWARE LIST:

A		1PC	N723P171442: C*1 D*1 H*1
B		1PC	N723P171445: C*1 E*1 H*1
C		5PCS	N723P171446: C*1 F*1 H*1
D		1PC	N723P171451: C*1 F*1 H*1
E		1PC	N723P171453: C*1 F*1 H*1
F		3PCS	N723P171455:G*1 I*2 J*2 K*28 L*28 M*28 N*28 O*28 P*1
G		1PC	
H		5PCS	N723P171457: A*1 B*1
I		2PCS	
J		2PCS	
K		28PCS	
L		28PCS	
M	 M 8*60M M	28PCS	
N	 M 8	28PCS	
O	 M 8*30*2M M	28PCS	
P	 M 8	1PC	

1

X 5

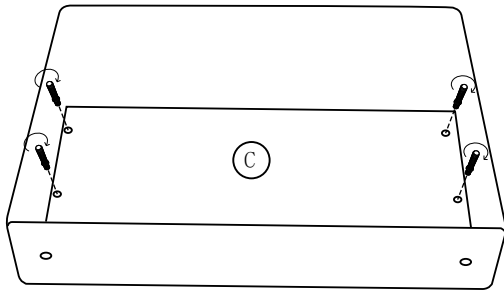

As shown, insert screws into the hole position and tighten clockwise.

M \*20

2

X 1

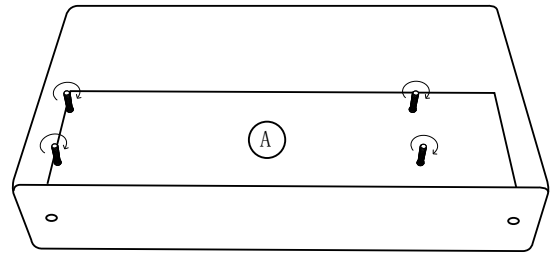

As shown, insert screws into the hole position and tighten clockwise.

M \*4

3

X 1

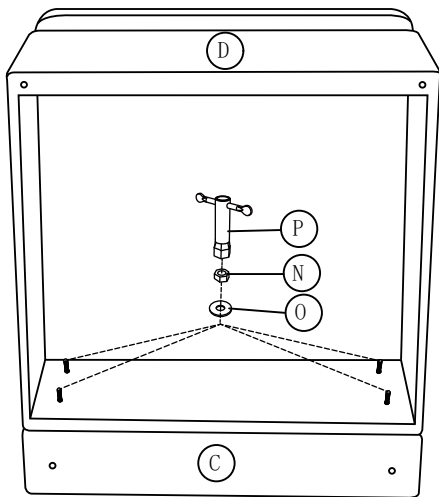

N\*4 Sequence the Washer and Nut as shown, then tighten clockwise with socket wrench.  
O\*4

4

X 1

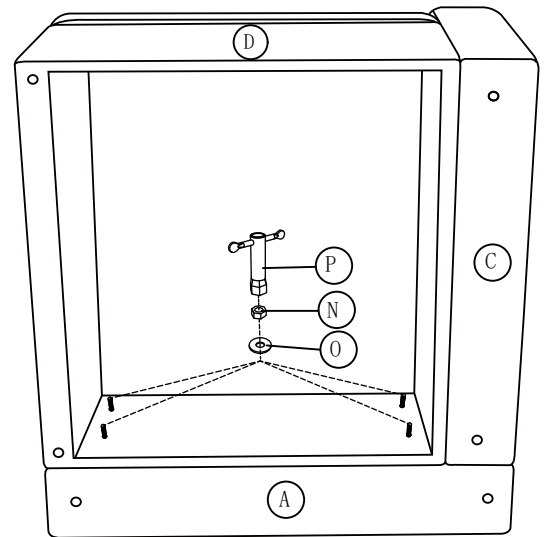

N\*4 Sequence the Washer and Nut as shown, then tighten clockwise with socket wrench.  
O\*4

5

X 1

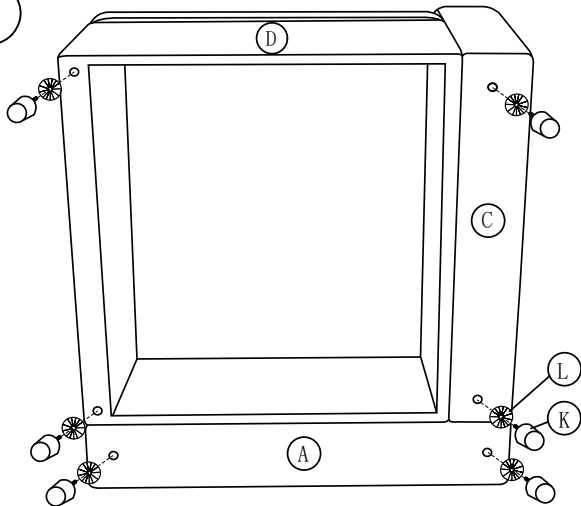

L\*4 Place one Plastic Washer on the Leg screw, then insert screw into the hole position. Tighten by turning the leg clockwise as shown.  
K\*4

6

X 1

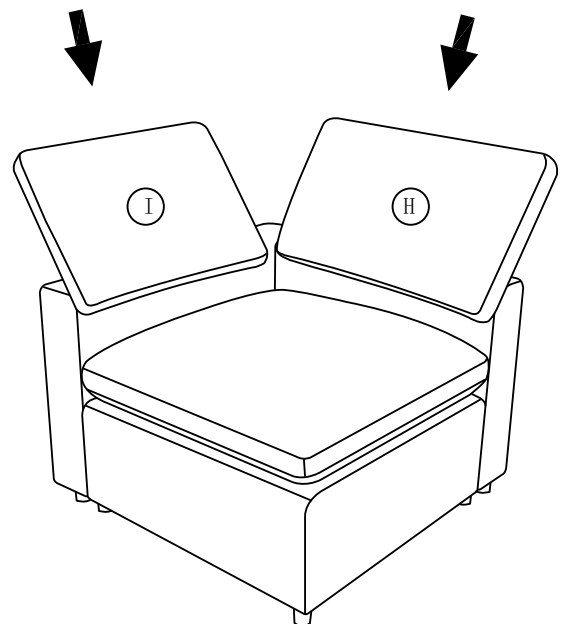

7

X 1

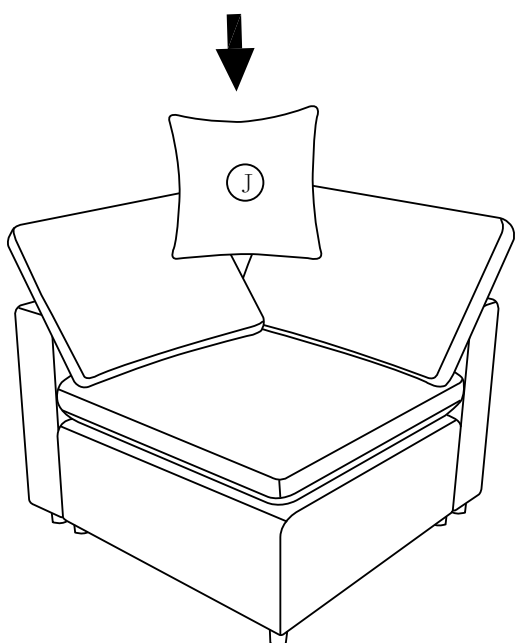

8

X 1

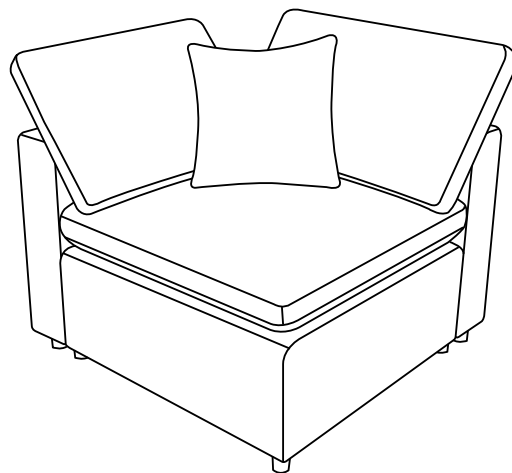

9

X 3

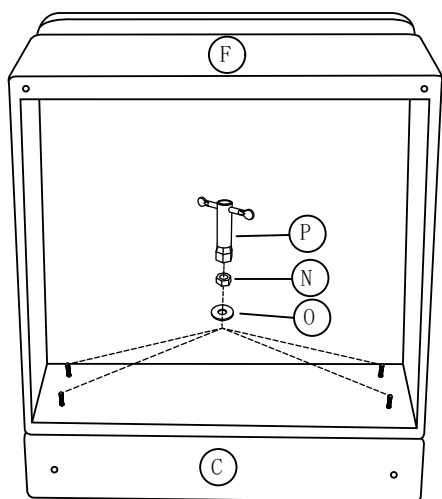

N\*12 Sequence the Washer and Nut as shown, then tighten clockwise with socket wrench.  
O\*12

10

X 3

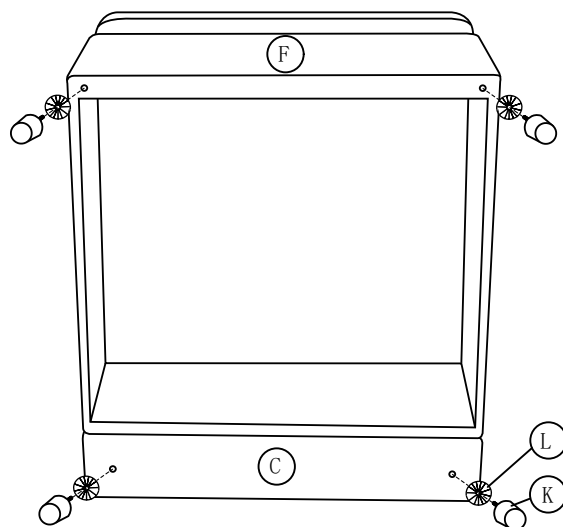

L\*12 Place one Plastic Washer on the Leg screw, then insert screw into the hole position. Tighten by turning the leg clockwise as shown.  
K\*12

11

X 3

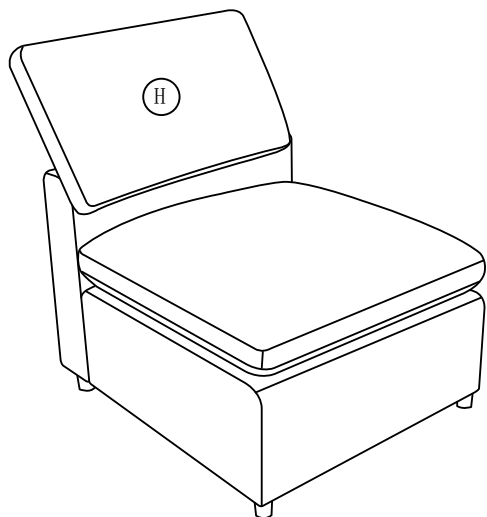

12

X 3

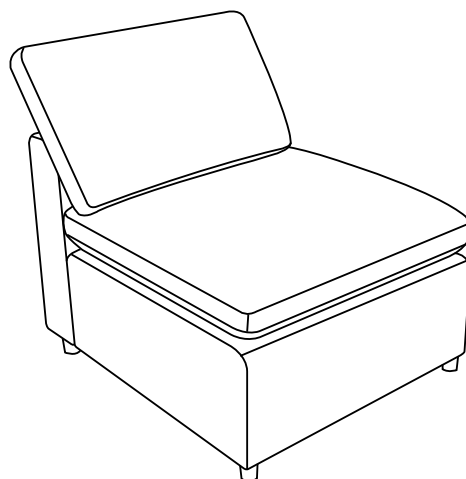

13

X 1

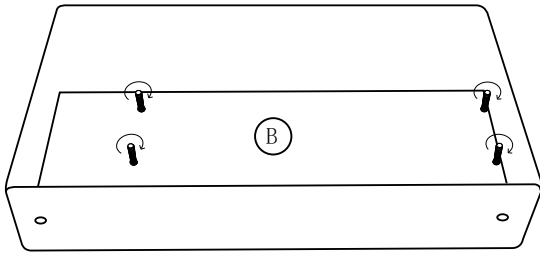

As shown, insert screws into the hole position and tighten clockwise.

M \*4

14

X 1

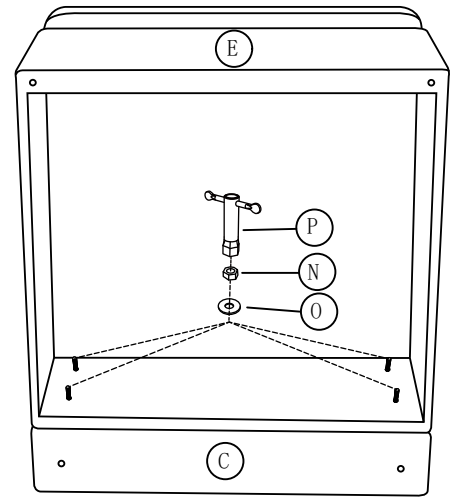

N\*4 Sequence the Washer and Nut as shown, then tighten clockwise with socket wrench.

O\*4

15

X 1

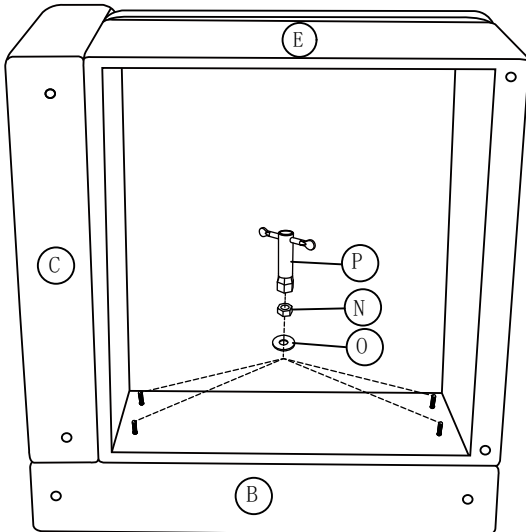

N\*4 Sequence the Washer and Nut as shown, then tighten clockwise with socket wrench.

O\*4

16

X 1

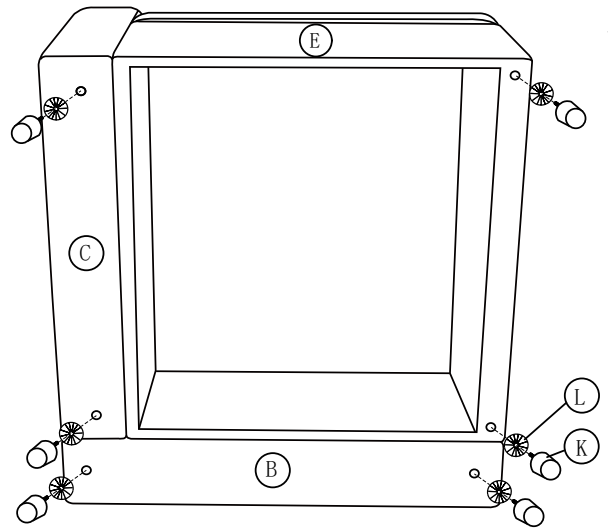

L\*4 Place one Plastic Washer on the Leg screw, then insert screw into the hole position. Tighten by turning the leg clockwise as shown.

K\*4

17

X 1

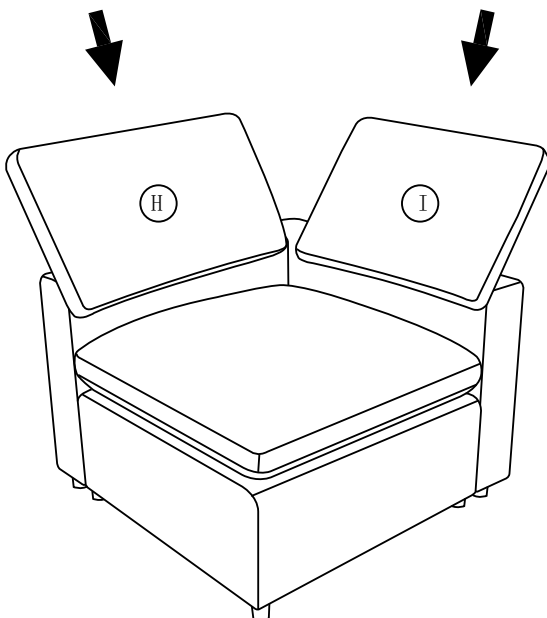

18

X 1

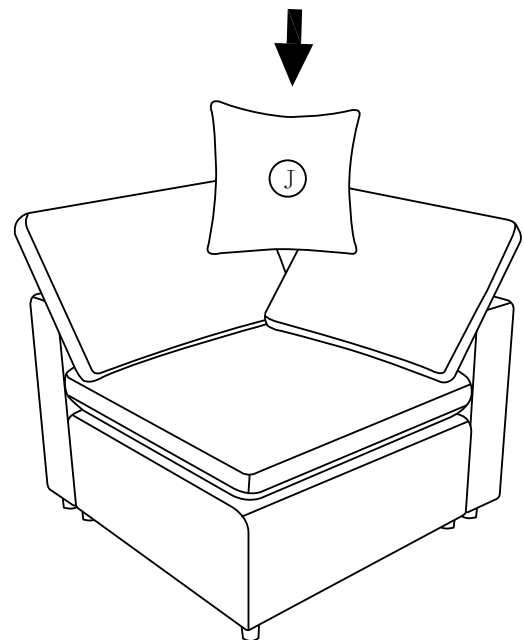

19

X 1

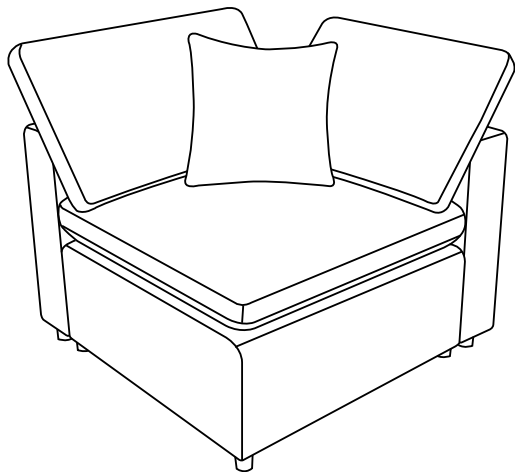

20

X 1

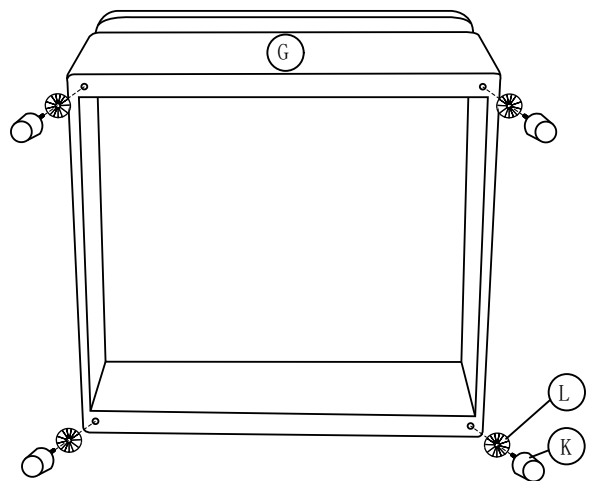

L\*4 Place one Plastic Washer on the Leg screw, then insert screw into the hole position. Tighten by turning the leg clockwise as shown.  
 K\*4

21

