

# User Instructions

## Reclining Chair

Please read the Instruction Manual below carefully before use.

This is a Reclining Chair. At anytime in a reclined seat position or in the upright position, you may enjoy a rocking motion by using your body weight in a back-front rocking motion.

Supervise children when they are using this Recliner.

### To get into a reclined posture - Recline backrest

Sit squarely in the seat.

Place your feet apart .

Place your left and right arm onto the armrest.

Synchronize a backward push with your arms and back.

Use your body weight and push backwards into the seat into you achieve a fully reclined position.



### To get out of chair - move Seatback into Upright Position

Tilt your body weight slightly forward and upwards.

The seat back will come up to an upright position.

Where necessary, use either of your arms to help lift and push yourself out of the seat.





# Assembly Instructions

**Caution :You must read this before you proceed**

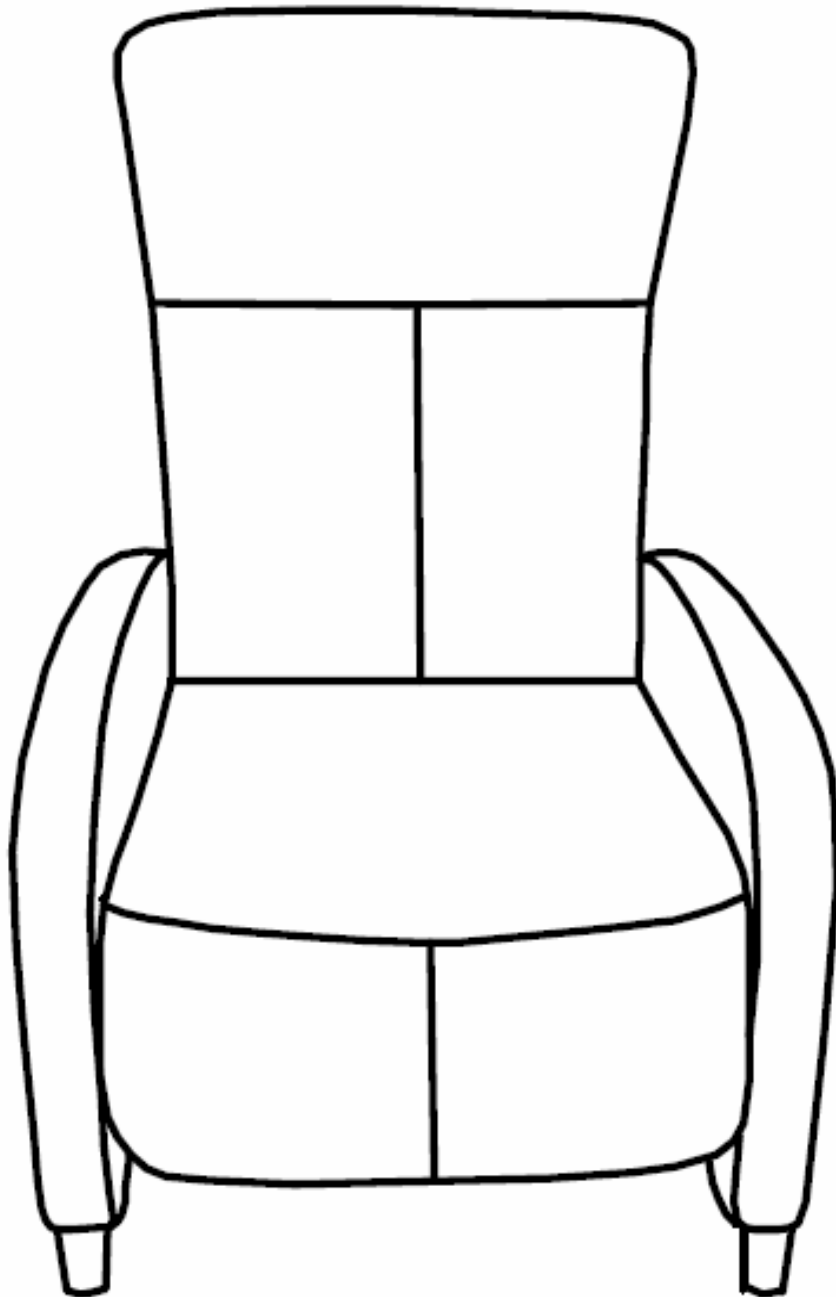
## Reclining Chair

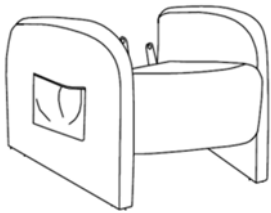
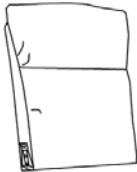

# Parts List

Label	Picture	Description	QTY
A		Chair Base	1
B		Chair Backrest	1
C		Wooden Leg	4
D		Washer Ring	7

# Assembly Preparation

## Before Beginning Assembly:

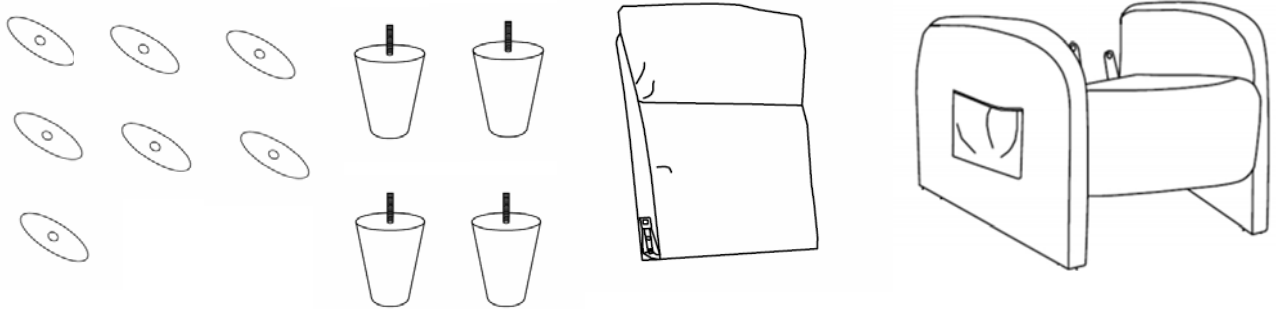

- Read instructions, cover to cover-



- Have 2 adults on hand for assembly-



- Do not assemble on flooring or carpet-



- Assemble on a clean non-marring surface (packing foam)-



- Save all packaging until finished-

# Assembly Steps

## Step 1

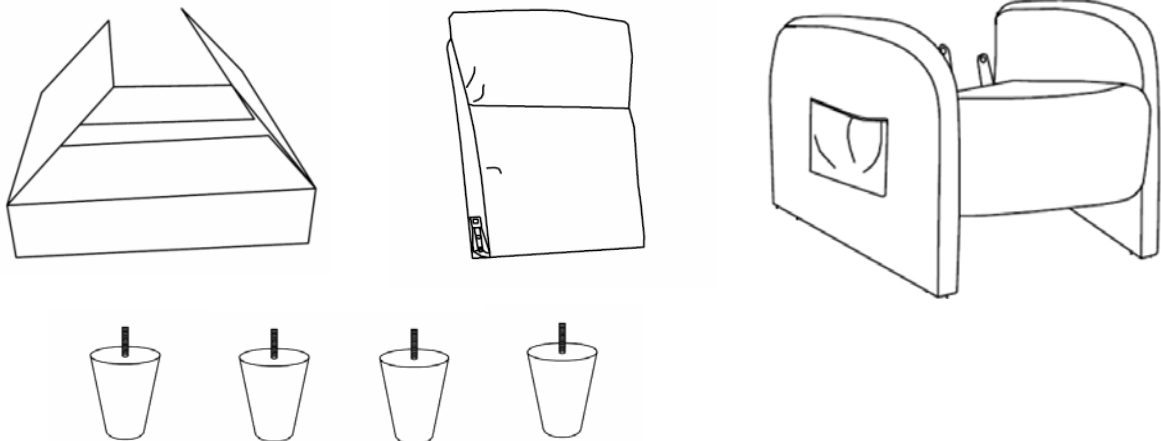

Unpack the Chair as shown.

Open the inner box and take out the four Wooden Legs(C) provided.

**Caution: The Chair parts are large and heavy, always have a second adult to assist you when moving and lifting them.**

## Step 2

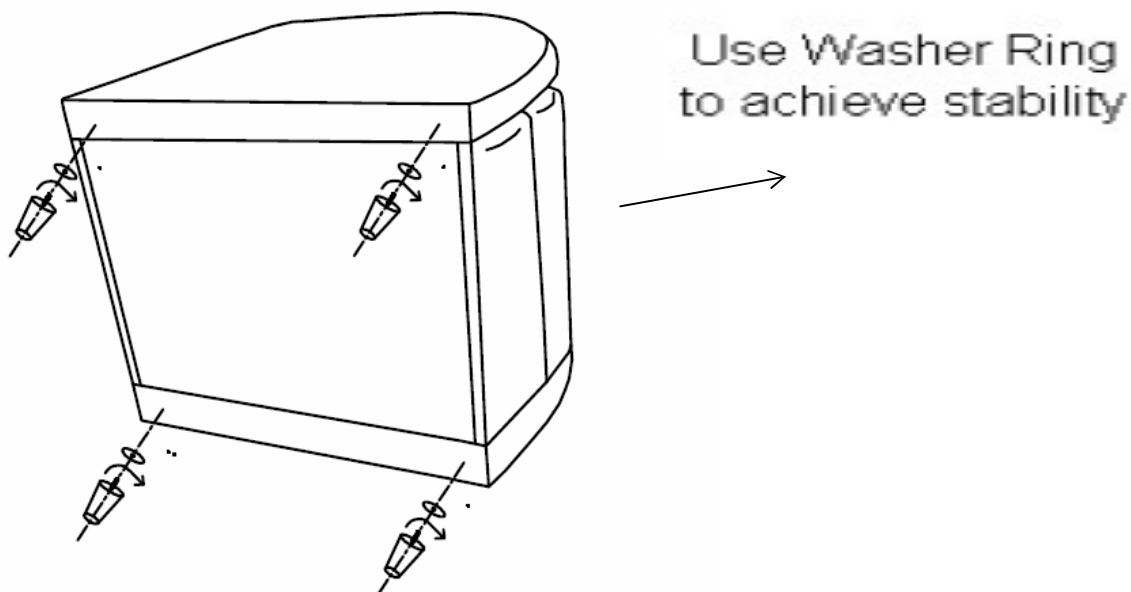

Turn the Chair Base(A) on its side on a clean, non-marring surface.

Install the first Wooden Leg(C) into the bottom of the Chair Base(A) by placing one Washer Ring(D) onto the threaded stem.

**NOTE: The use of the Washer Rings are OPTIONAL, they are especially useful to help alleviate slight wobbles.**

Insert the threaded stem of Wooden Leg(C) into the threaded hole of Chair Base(A) then tighten by turning the leg clockwise until the leg is completely secure.

Repeat this process with the remaining three legs.

### Step 3

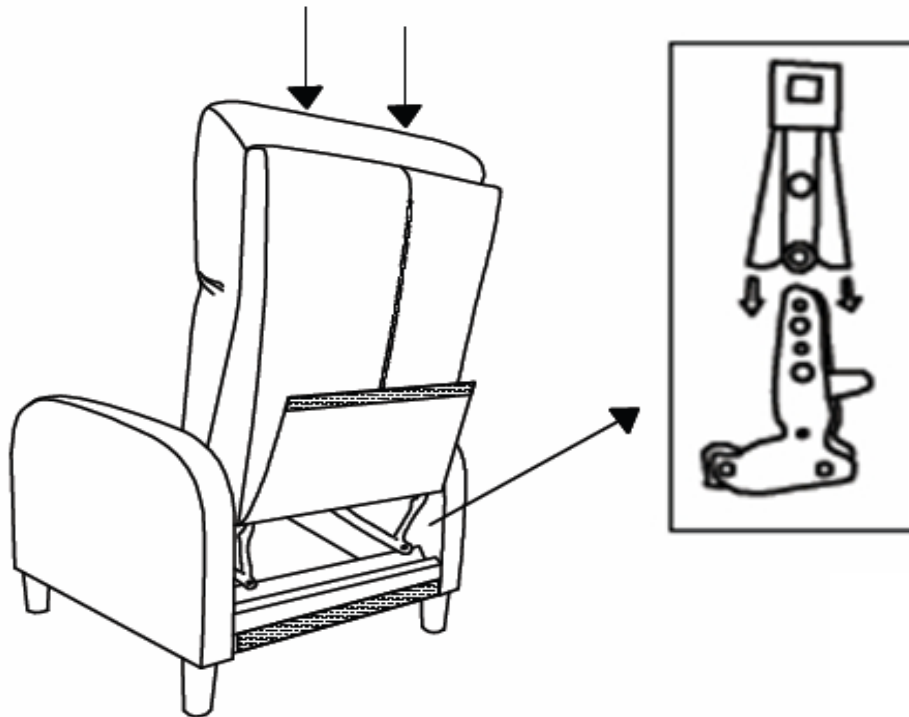

Stand the Chair Base(A) rightside up.  
Stand behind the Chair Base(A) while holding up the Chair Backrest(B).  
Tilt the Chair Backrest(B) slightly forward, then insert the small metal arms on the sides of the Chair Backrest into the prefabricated slide lock gadget on the Chair Base as shown above.  
Firmly but gently, push the Chair Backrest(B) downwards until the Backrest is fully slotted and locked into position.

### Step 4

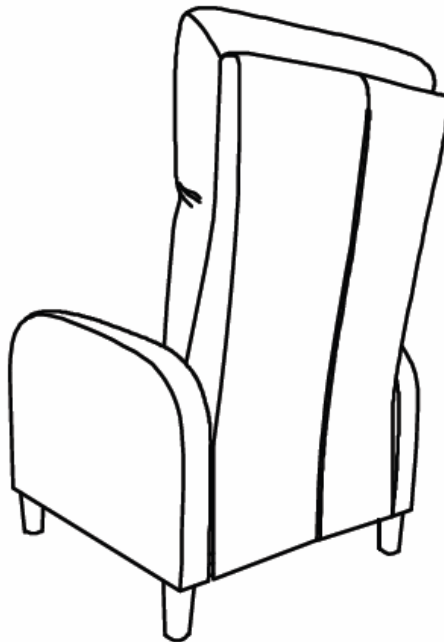

Smooth down the fabric flap on the Chair Backrest(B).  
Run your hand down both sides of the flap, from top to bottom, allowing the velcro strip to adhere to the Chair Base(A).  
Your Recliner is ready for use.

## Care & Maintenance



• Do not put hot items directly on furniture surface.



• Do not clean furniture with harsh cleansers or polish.



• Do not place furniture under direct sunlight.



• Do not place furniture near heating or cooling vents.



• Do not write on furniture without a padded barrier to protect the surface.



• Do not place furniture outside. For indoor use only.



• Not for commercial use. For residential use only.



• Stains may be removed with mild soap solution and damp cloth.



• Dust and pick-up spills using a clean, non-colored, lint-free cloth.