

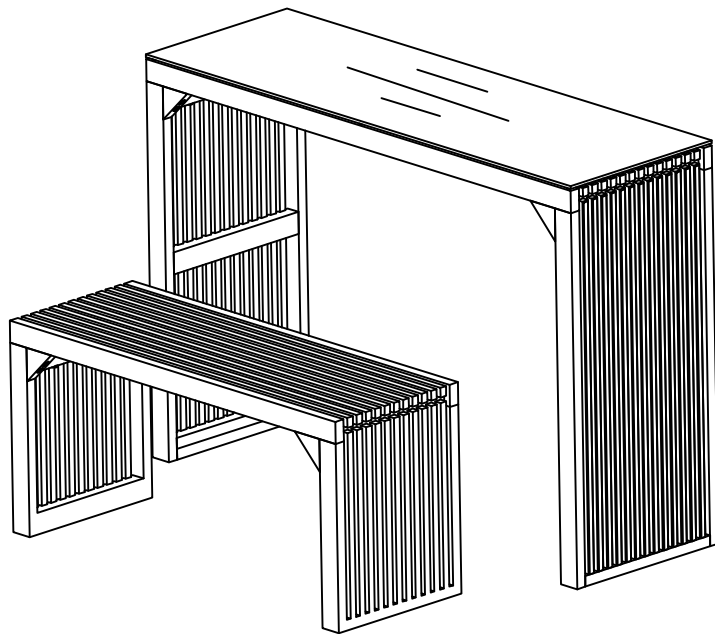









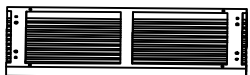

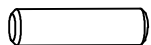

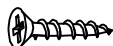





# Grid stool-L

Item : DX-005

## Assembly Instruction

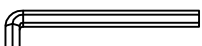

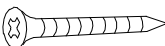
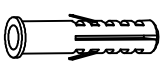
Number	Parts	Quantity
<b>A</b>	 Panel	1PC
<b>B</b>	 Table leg	2PCS
<b>C</b>	 Panel	1PC
<b>D</b>	 Table leg	2PCS
<b>E</b>	 Glass	1PC
<b>F</b>	 Wooden Dowel ø8mm	8PCS
<b>G</b>	 Triangular fixation	8PCS
<b>H</b>	 Console Table Triangular fixation	2PCS
<b>I</b>	 Screw	1PCS
<b>J</b>	 Screw ø6*25mm	4PCS
<b>K</b>	 Screw ø6*30mm	16PCS
<b>L</b>	 Screw ø8*70mm	8PCS

Number	Parts	Quantity
<b>M</b>	 Spring gasket ø6mm	20PCS
<b>N</b>	 Gasket ø6mm	20PCS
<b>O</b>	 Spring gasket ø8mm	8PCS
<b>P</b>	 Gasket ø8mm	8PCS
<b>Q</b>	 Silicone pad	6PCS
<b>R</b>	 Non slip furniture pads	8PCS
<b>S</b>	 Allen Key ø4mm	1PC
<b>T</b>	 Allen Key ø5mm	1PC
<b>U</b>	 Anti tipping hardware	2PCS
<b>V</b>	 Wooden screws ø8*40	1PC
<b>W</b>	 Aircraft rubber stopper ø8*38	1PC
<b>X</b>		1PC

**STEP 1**



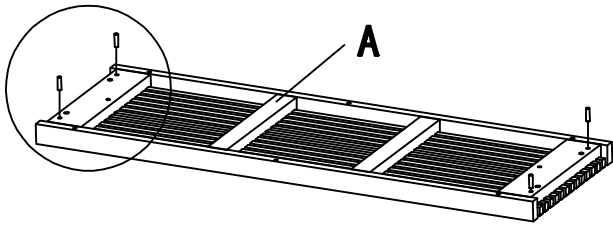
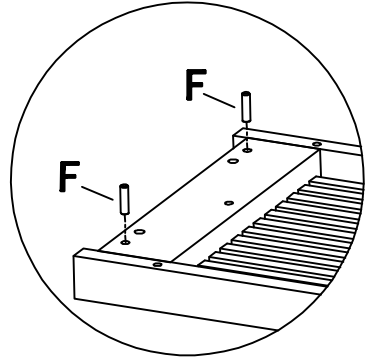

 **F X4**

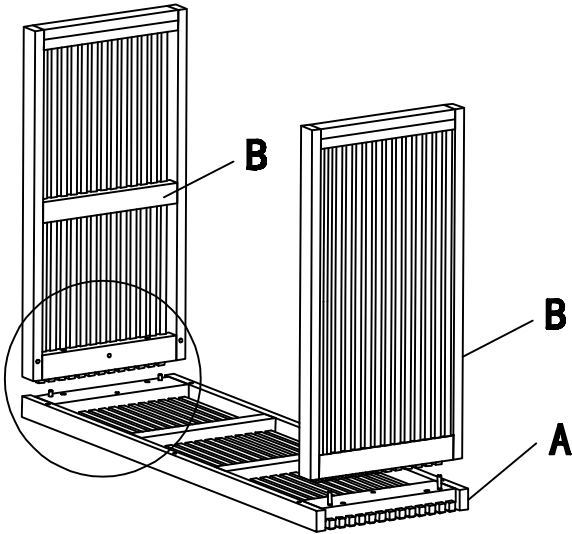
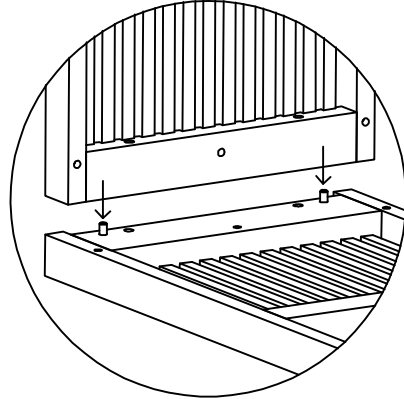

**STEP 2**





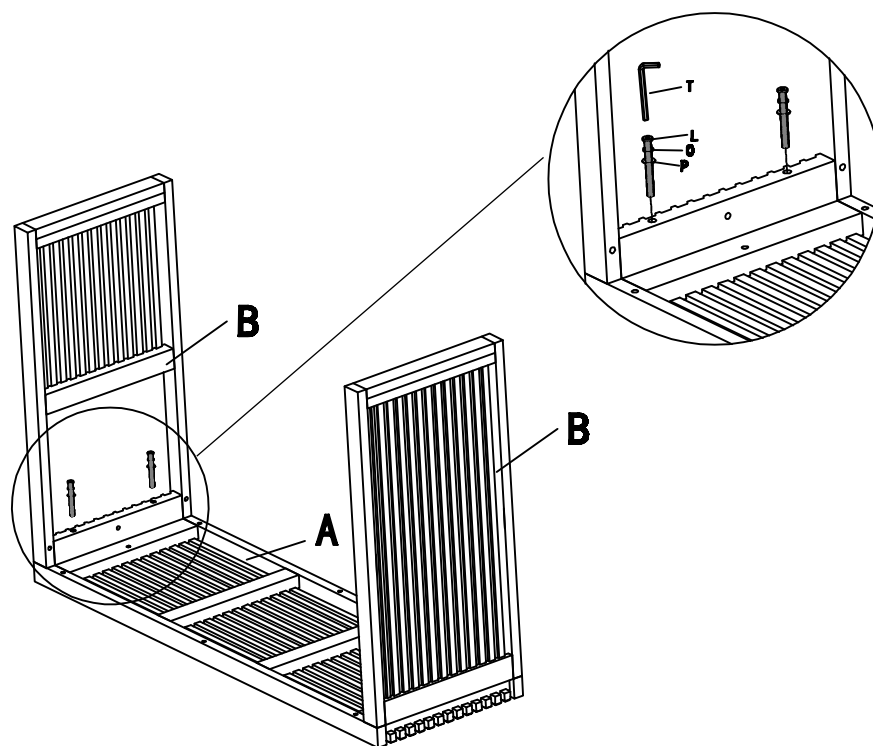

## STEP 3

	L	X4
	O	X4
	P	X4
	T	X1





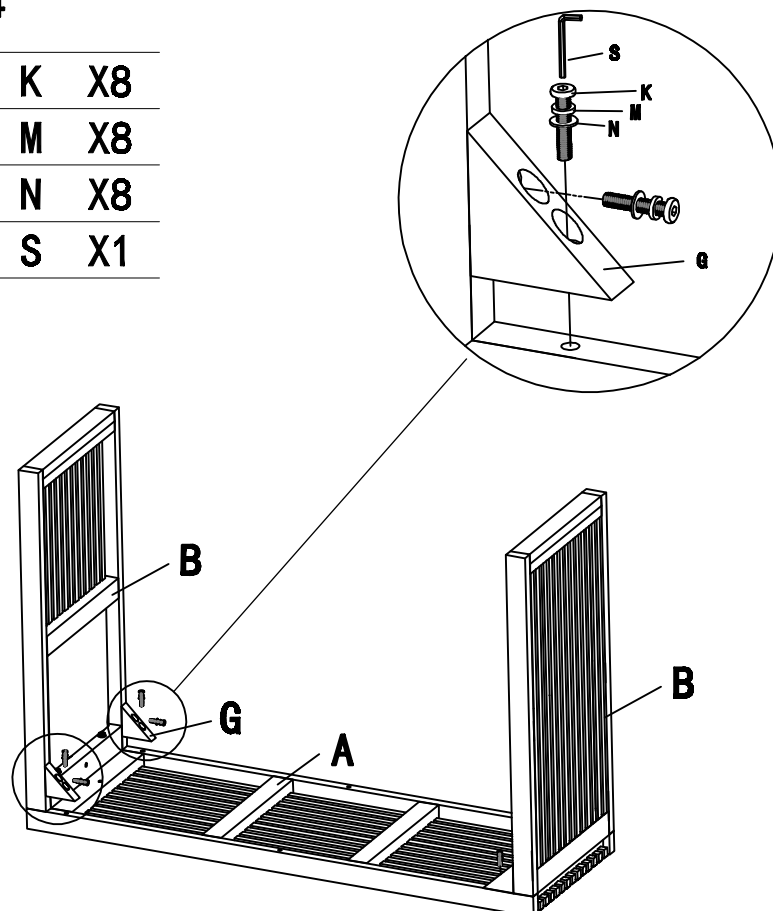

## STEP 4

	K	X8
	M	X8
	N	X8
	S	X1



**STEP 5**

	<b>J</b>	<b>X4</b>
	<b>M</b>	<b>X4</b>
	<b>N</b>	<b>X4</b>
	<b>S</b>	<b>X1</b>

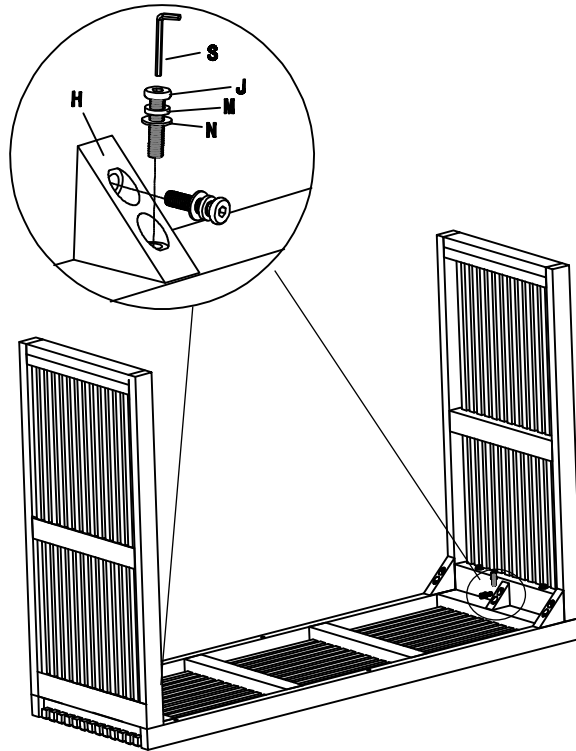
**STEP 6**

	<b>R</b>	<b>X4</b>
---	----------	-----------

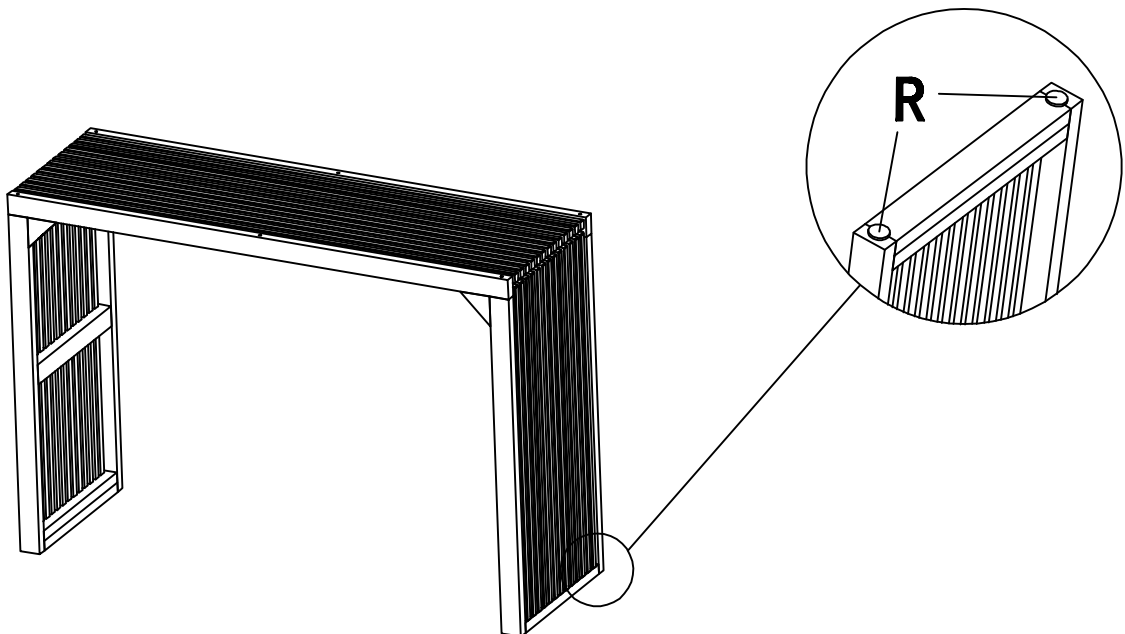

### STEP 7

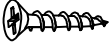
-  I X1

---

-  U X2

---

-  X X1

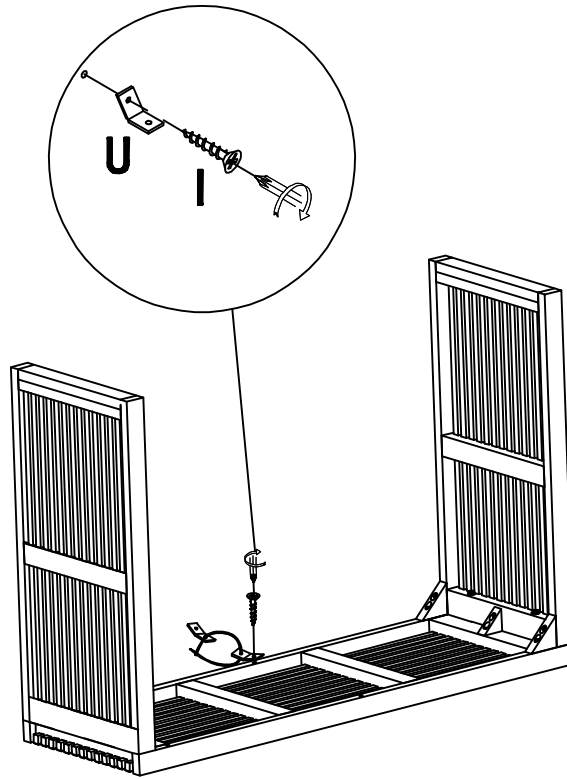

### STEP 8

-  W X1

---

-  V X1

Wall

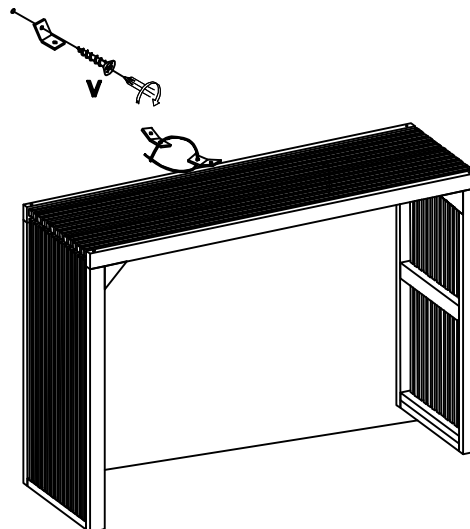
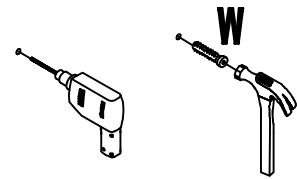

## STEP 9

---

 Q X6

---

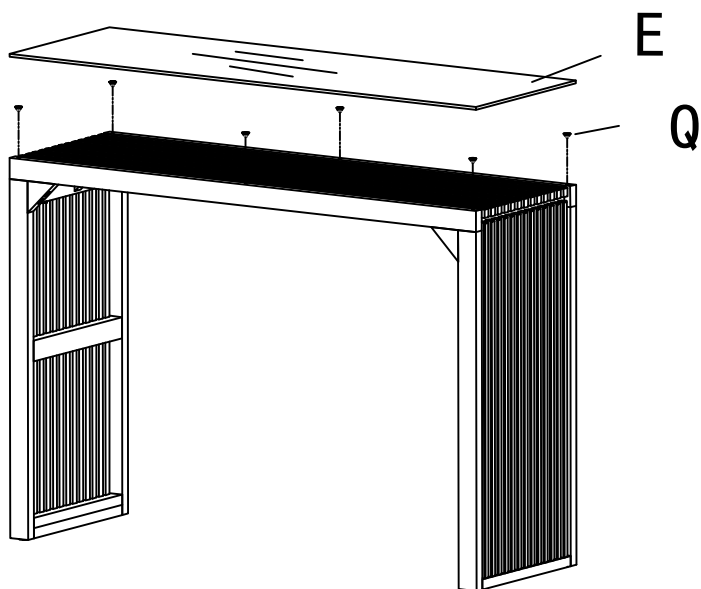

## STEP 10

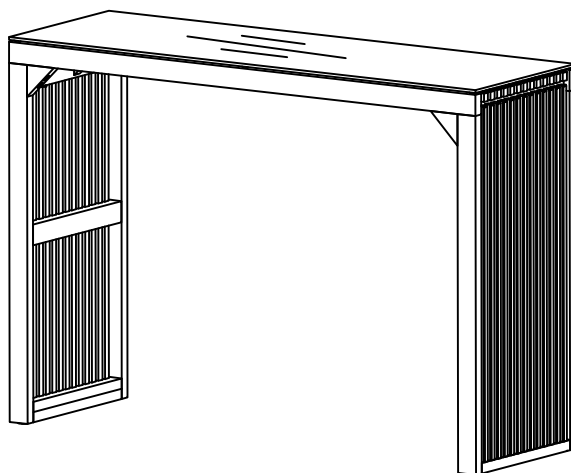

**STEP 11**

 **F X4**

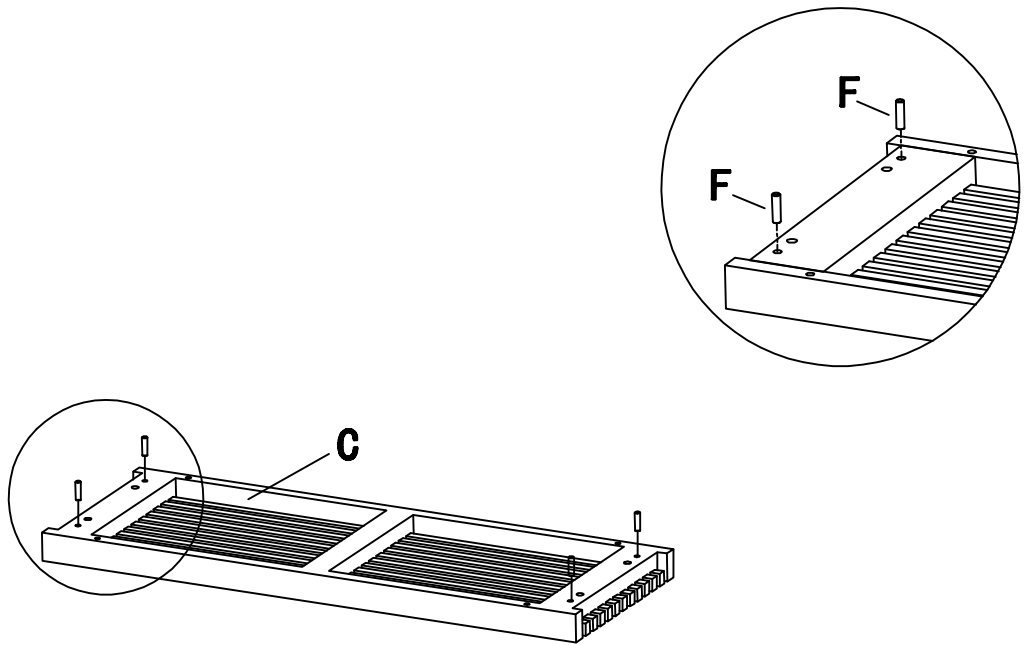



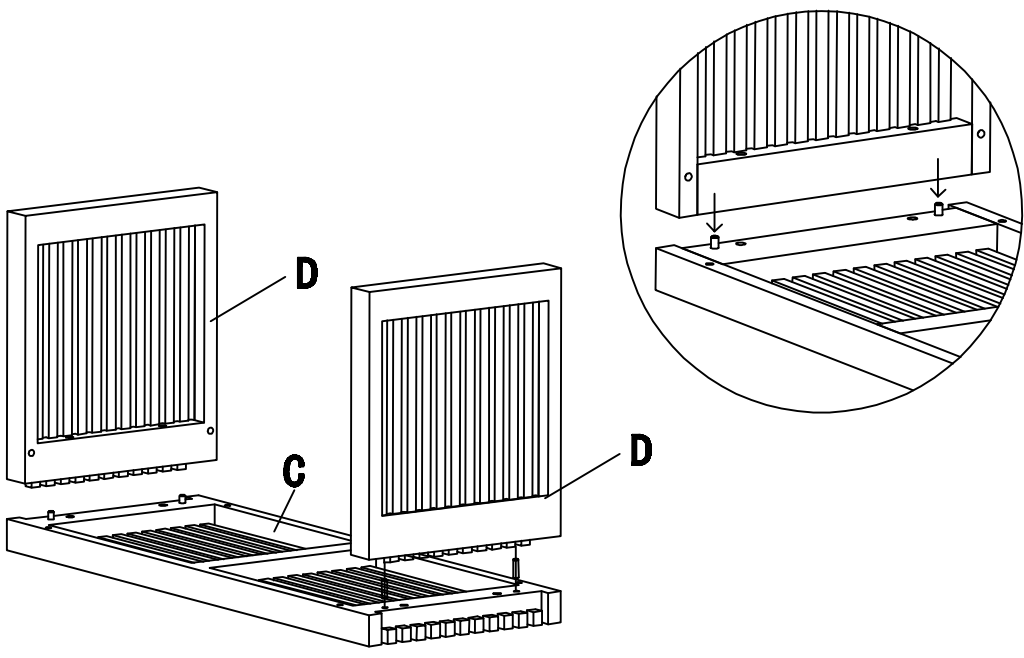

**STEP 12**







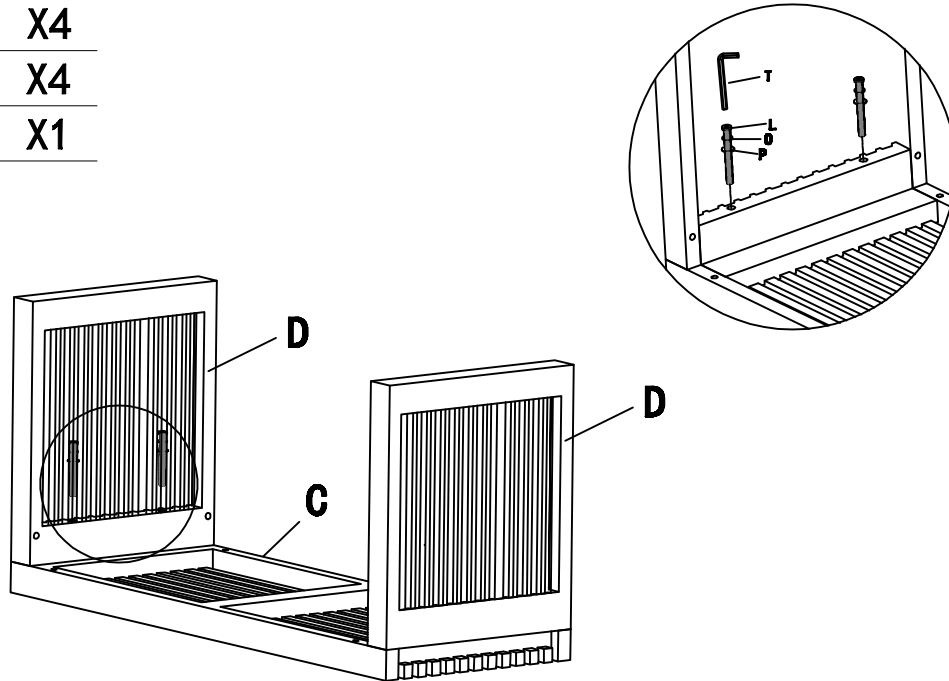

**STEP 13**

	L	X4
	O	X4
	P	X4
	T	X1

**STEP 14**

	K	X8
	M	X8
	N	X8
	S	X1

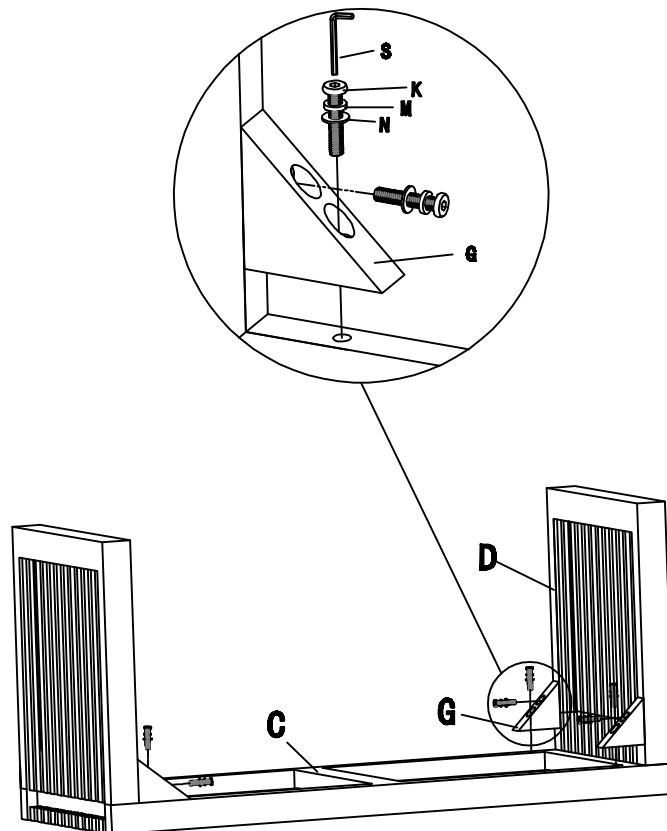

STEP 15

 R X4

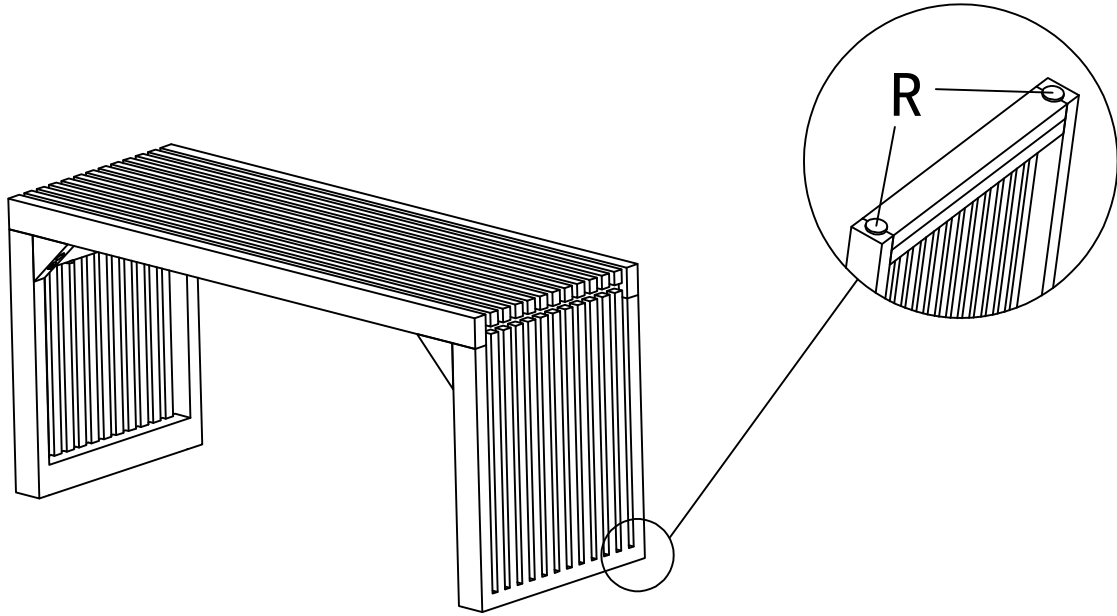

STEP 16

