

ASSEMBLY INSTRUCTIONS

DAY BED WITH 2 DRAWER

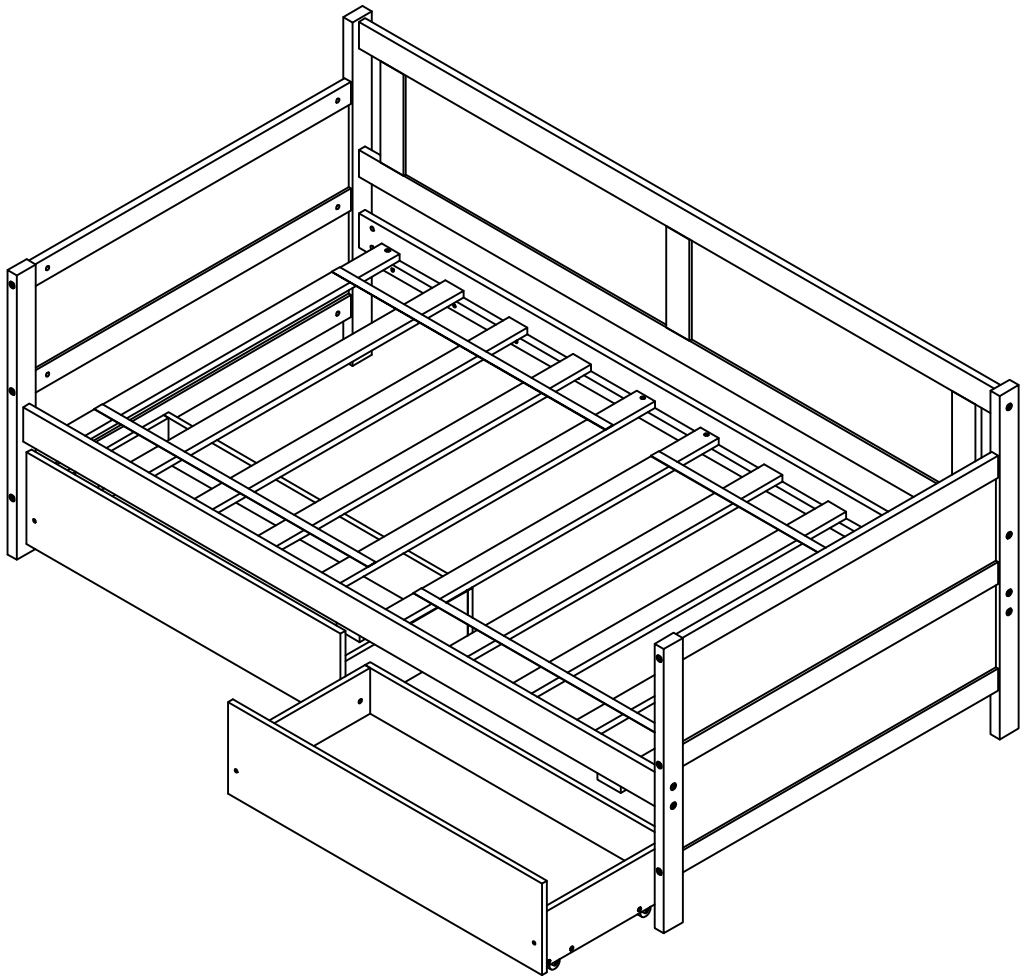





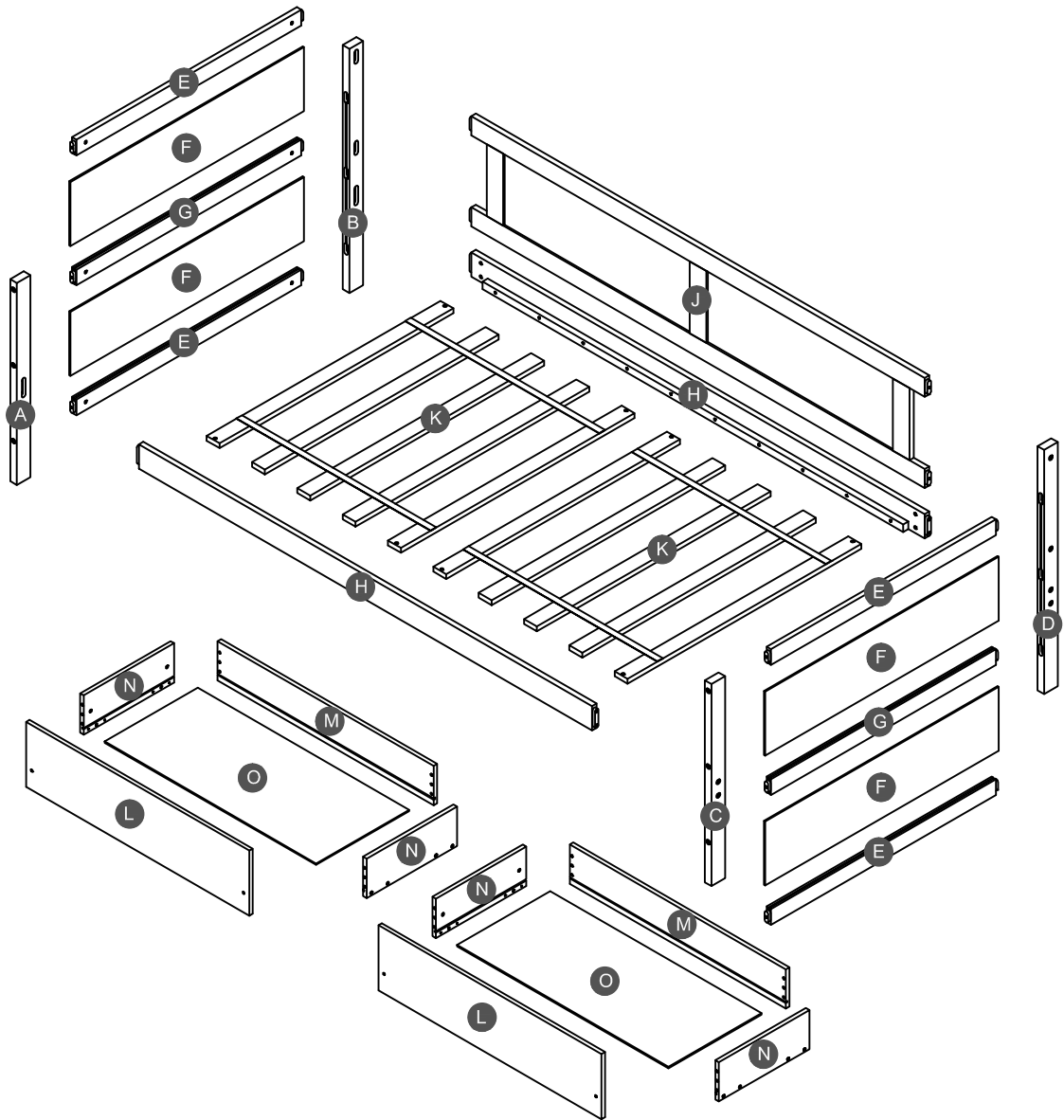



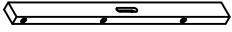

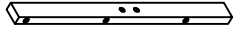
DN33706

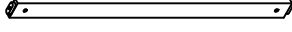

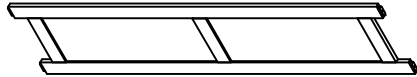
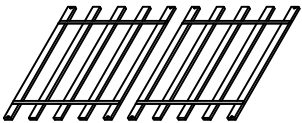
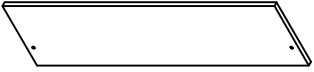
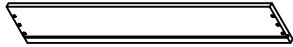

Detail View

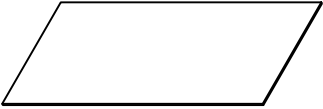

Part List

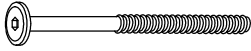
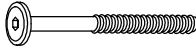
<p>A</p>  <p>Leg (Left Front)- 1pc</p>	<p>B</p>  <p>Leg (Left Back)- 1pc</p>	<p>C</p>  <p>Leg (Right Front)- 1pc</p>
<p>D</p>  <p>Leg (Right Back)- 1pc</p>	<p>E</p>  <p>Horizontal bars HB&FB- 4pcs</p>	<p>F</p>  <p>Side panel (HB&FB) - 4pcs</p>
<p>G</p>  <p>Horizontal center HB&FB- 2pcs</p>	<p>H</p>  <p>Side rail (Front & Back)- 2pcs</p>	<p>J</p>  <p>Guard rail (back)- 1pc</p>
<p>K</p>  <p>Slats - 10pcs</p>	<p>L</p>  <p>Drawer front panel- 2pcs</p>	<p>M</p>  <p>Drawer back panel - 2pcs</p>
<p>N</p>  <p>Drawer (Left/Right)- 4pcs</p>	<p>O</p>  <p>Drawer bottom - 2pcs</p>	

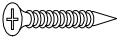
Hardware List

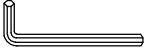
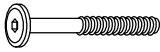
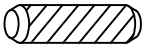
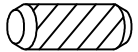
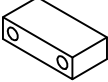
1  (Ø15)1/4"*100mm Hex-Head bolts (12pcs)	2  (Ø15)1/4"*80mm Hex-Head bolts (12pcs)	3  1/4"*15 (9.5mm) Horizontal-Hole bolts(32pcs)
4  Ø4*30mm Wood screws (30pcs)	5  100*54*20 mm Wheels (8pcs)	6  (1/4")4.5*58mm Allen key (1pc)
7  (Ø12)1/4"*60mm Hex-Head bolts (8pcs)	8  Ø8*30mm Wood dowel (16pcs)	9  Ø10*20mm Wood dowel (8pcs)
10  70*35*19 mm Wood support drawer (3pcs)		

ASSEMBLY TOOLS REQUIRED (NOT INCLUDED)

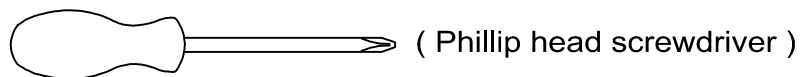

DO NOT USE POWER TOOLS TO ASSEMBLE THIS PRODUCT !

STEP 1:

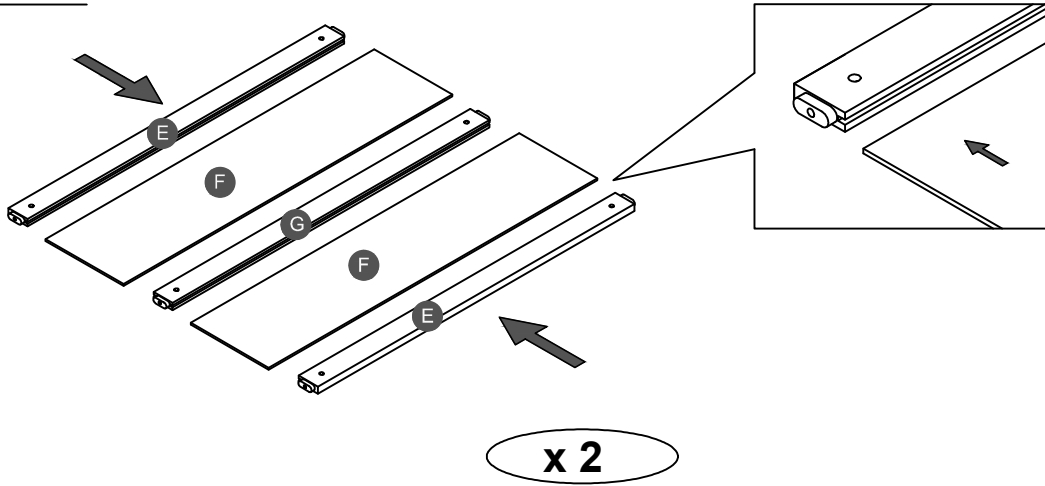

STEP 2:

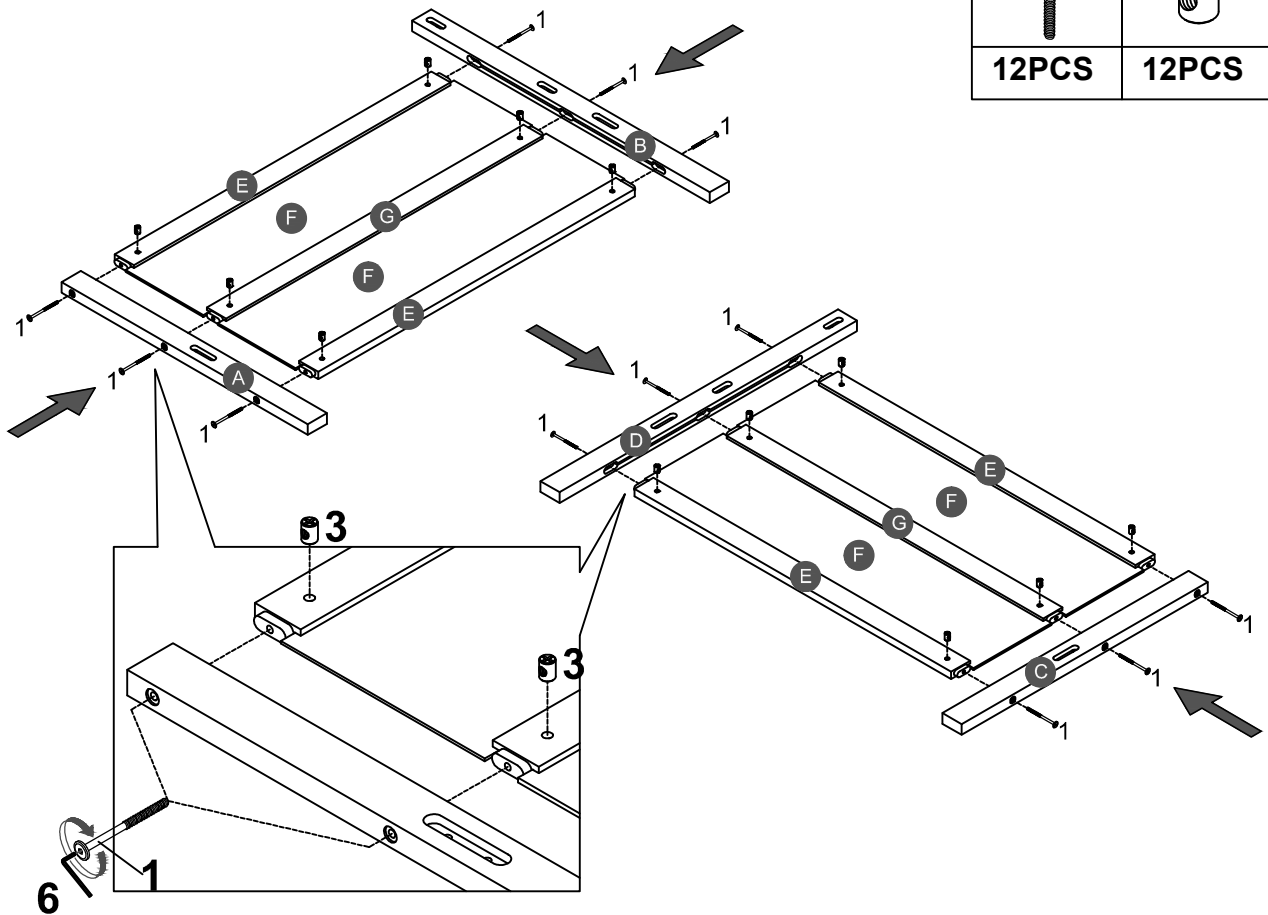

Note: Part 3 will face up with the "x" mark on it, otherwise it cannot be tightened

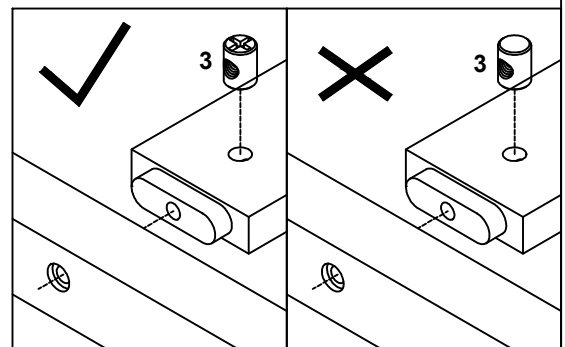

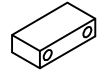

STEP 3:

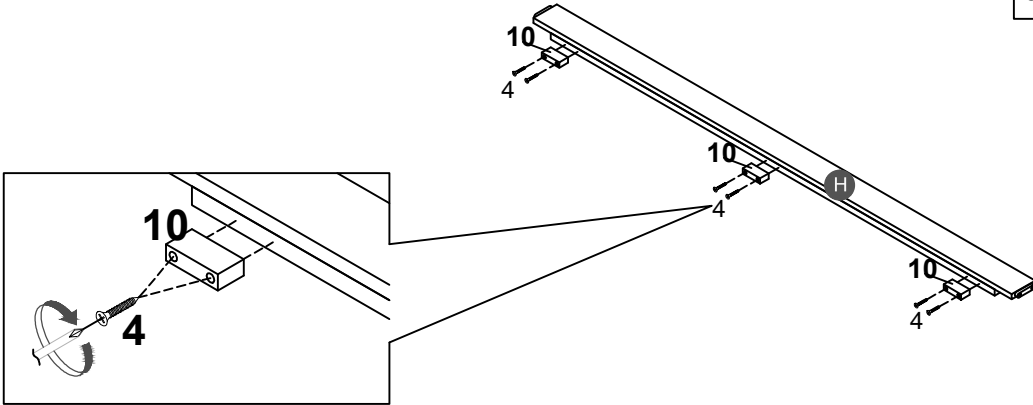
4		10	
6PCS		3PCS	



Wood support drawer (10) with side rail (front) by using screw (4).

STEP 4:

2		3	
12PCS		12PCS	

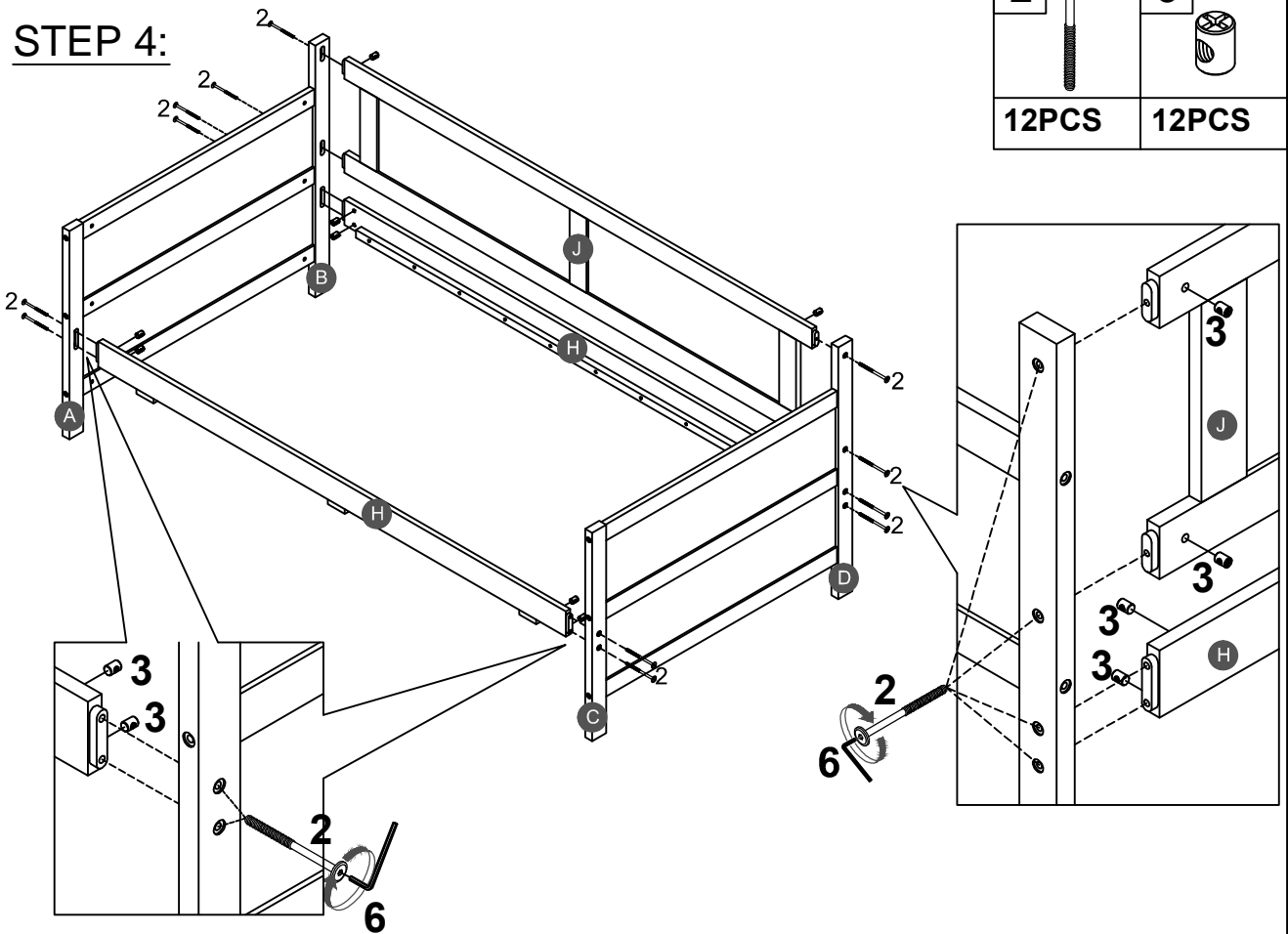

STEP 5:

4



8PCS

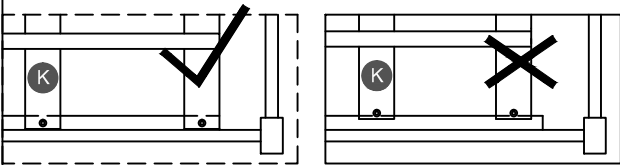
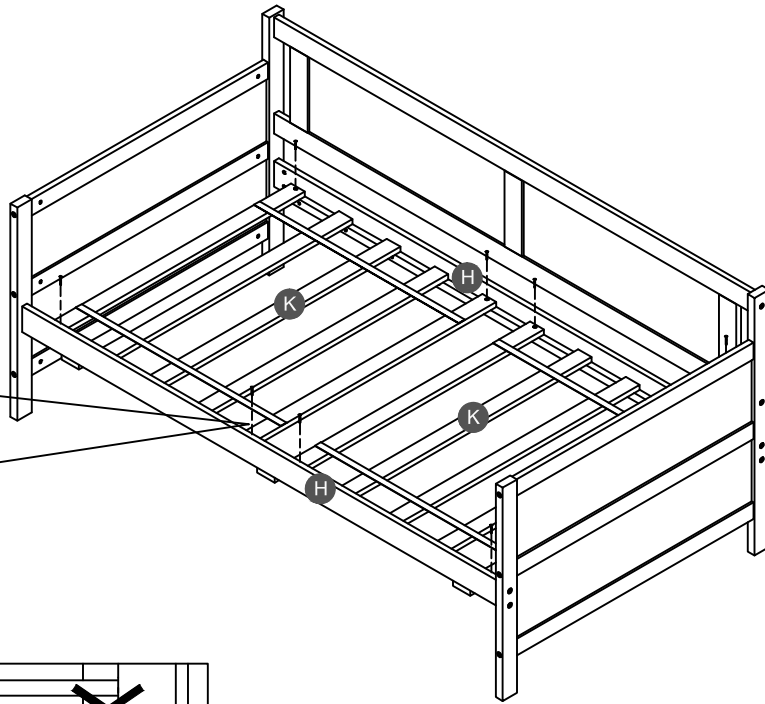
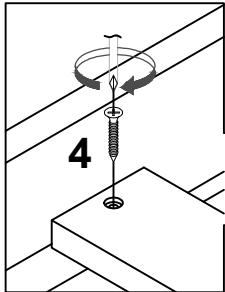

Note: Do not lock the screws of the bed slats to the outermost edge of the bed slats, you need to leave a certain space at the edges, otherwise it will cause the board to break

STEP 6:

3



4PCS

7



4PCS

8





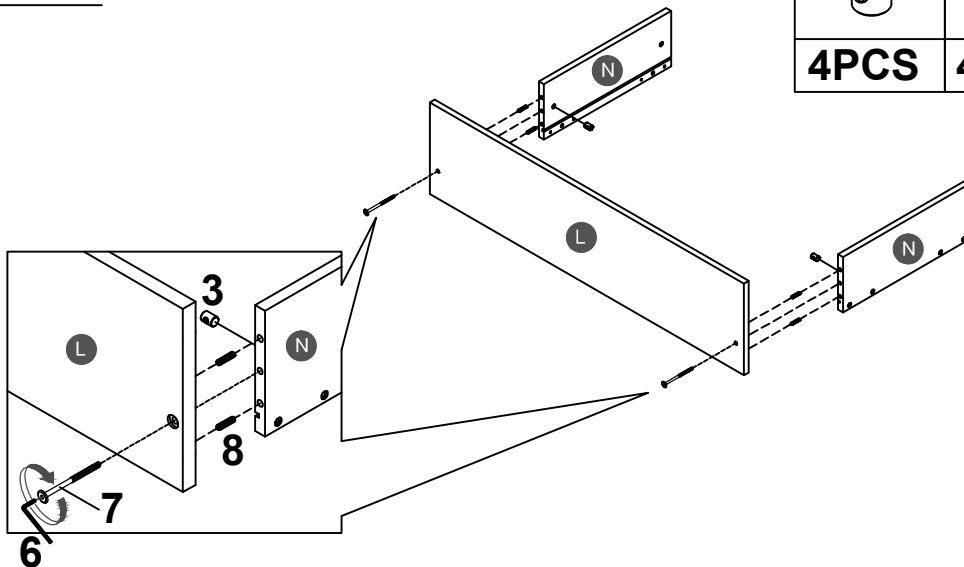

8PCS

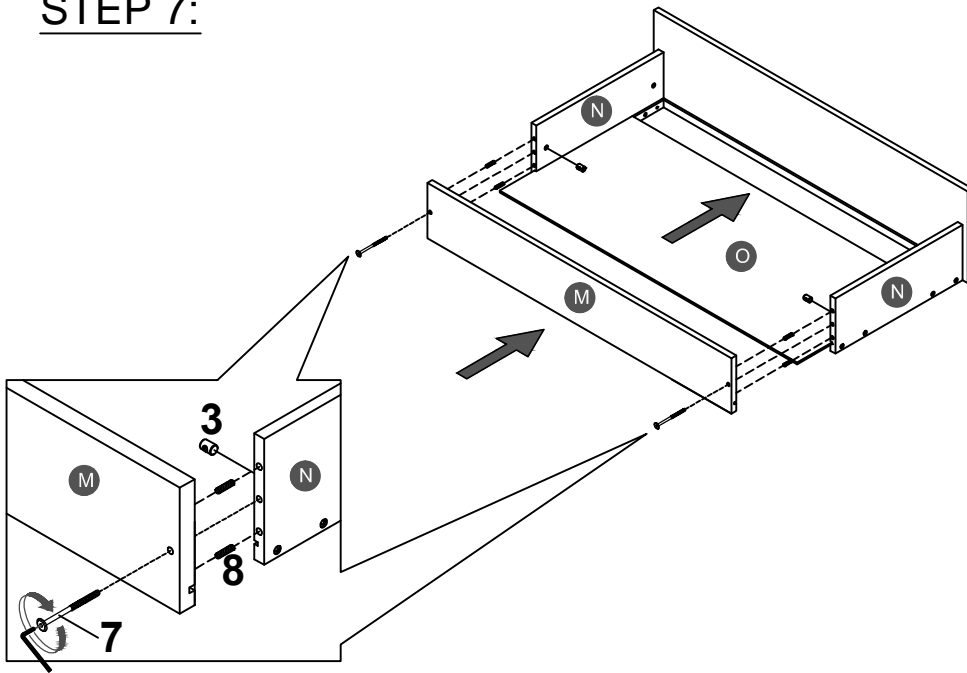

x 2

STEP 7:





3		7	
4PCS		4PCS	
		8	
		8PCS	

x 2

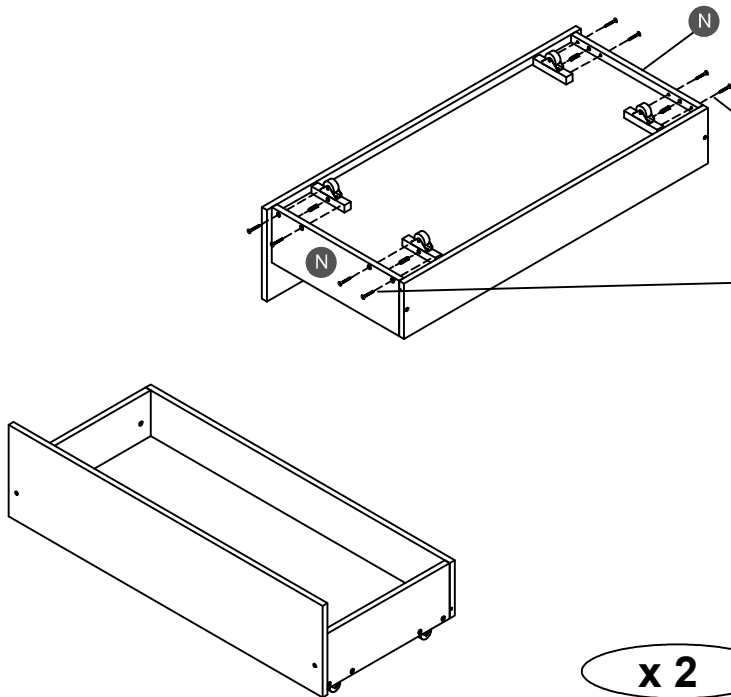
STEP 8:



4		5		9	
16PCS		8PCS		8PCS	

x 2

STEP 10:

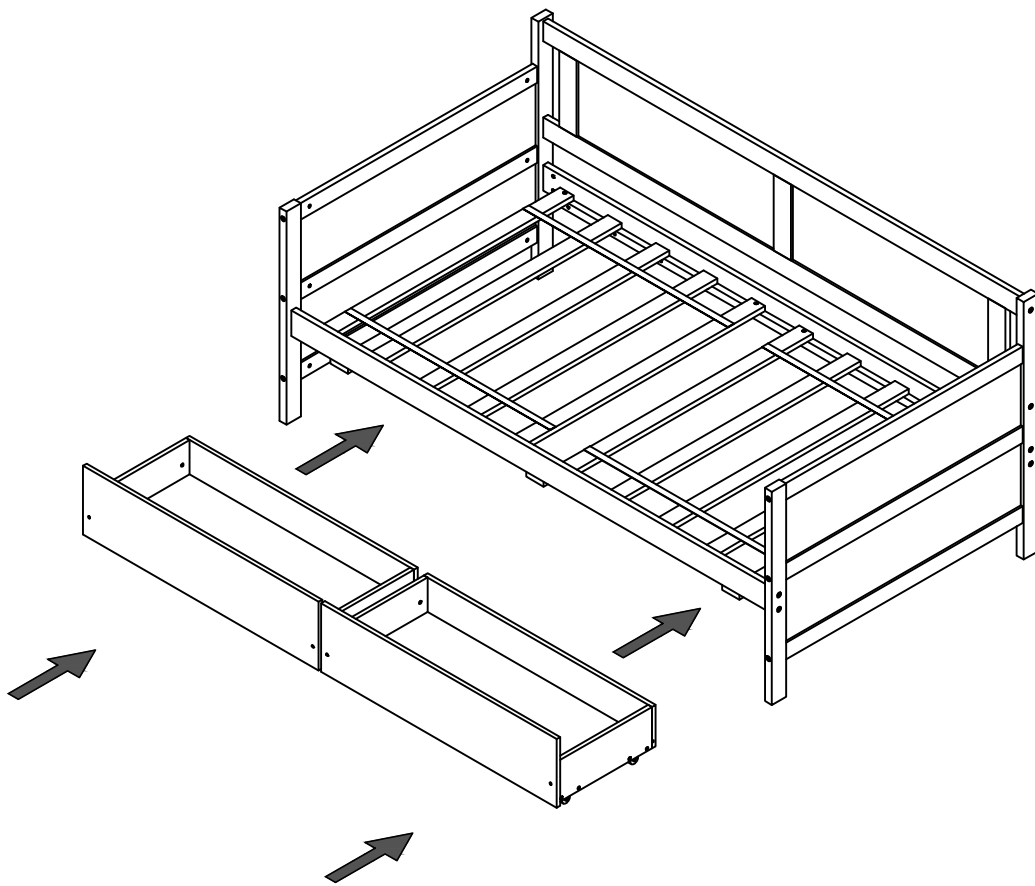

Push Drawer under the bottom of Day Bed.

