

HAPPINESS HAPPINESS INSTALLATION

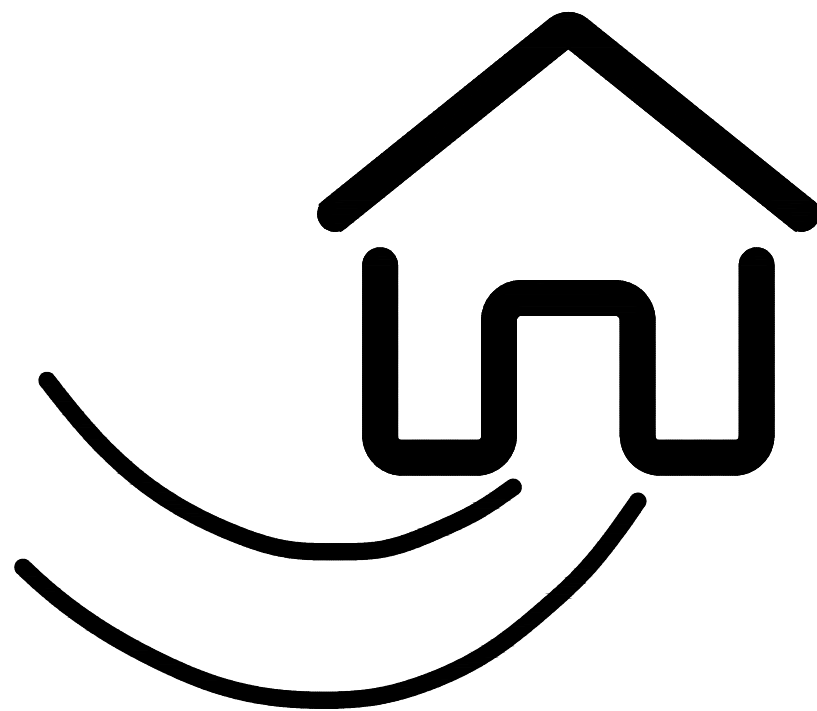

- If you have any questions with the product, please contact us by:
- **Email: customerservice@zoy-living.com**
(we will reply to you within 24 hours)

Assembly Instructions







ZY6692

Your recliner comes packaged in one box. Carefully remove all of components from the packaging and set aside for assembly.

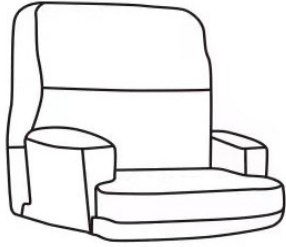
CAUTION:

DO NOT use any sharp objects to open plastic wrapped components as damage to product or components may result.

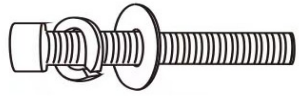
Package Contents

| | | | |
|---|---|---|---|
|  |  |  |  anti-slip floor pad |
| A *1 | B *1 | C *8 | D *8 |
|  |  spanner | | |
| E *8 | F *1 | | |

Step 1:

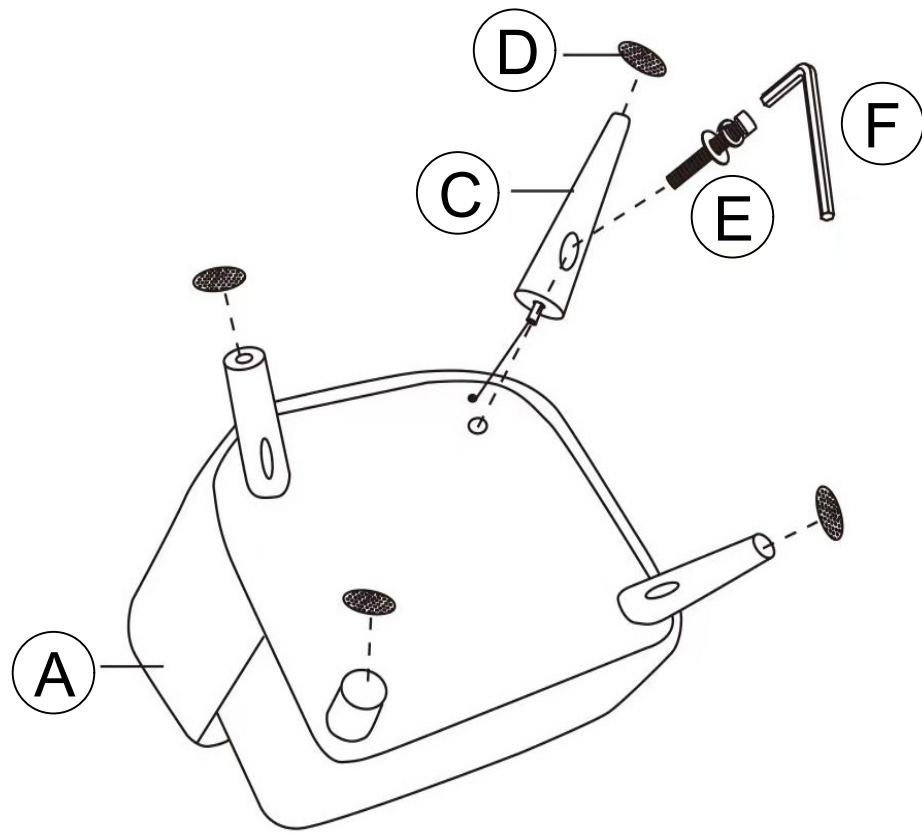

Step 2:

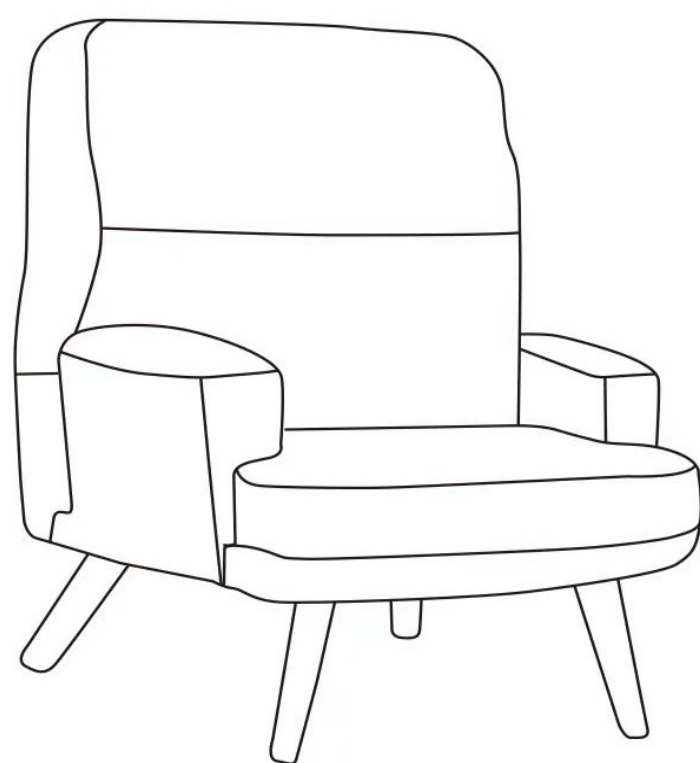

Step 3:

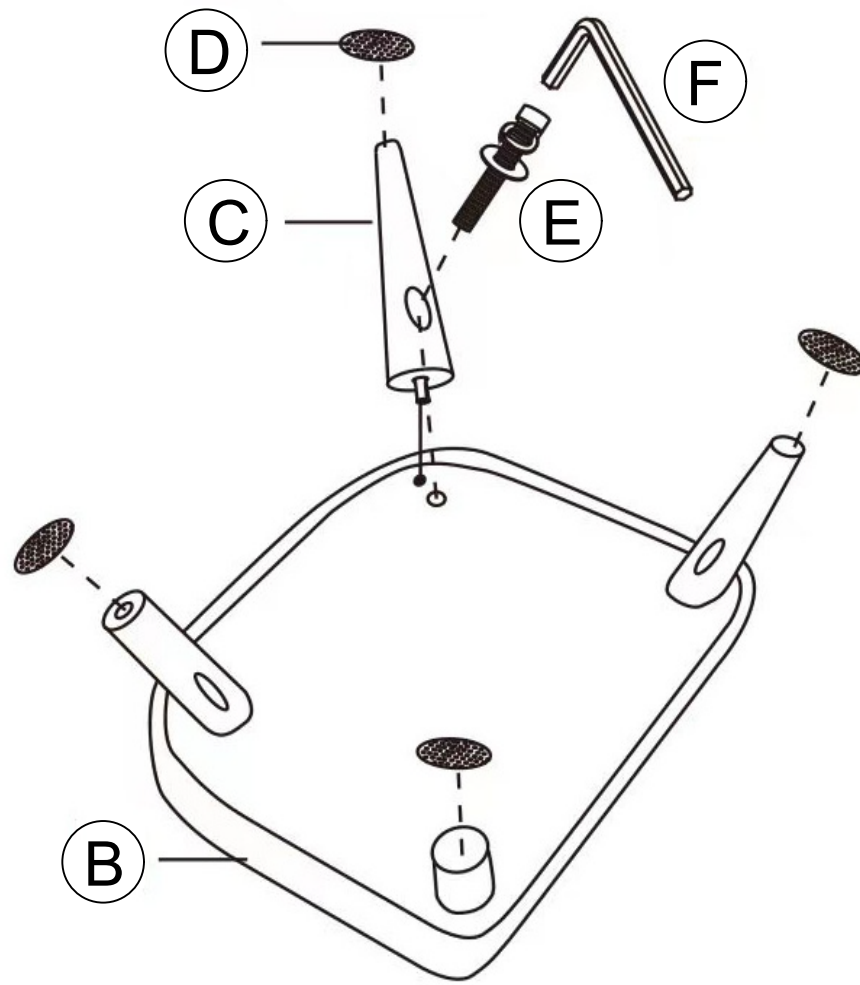

Step 4:

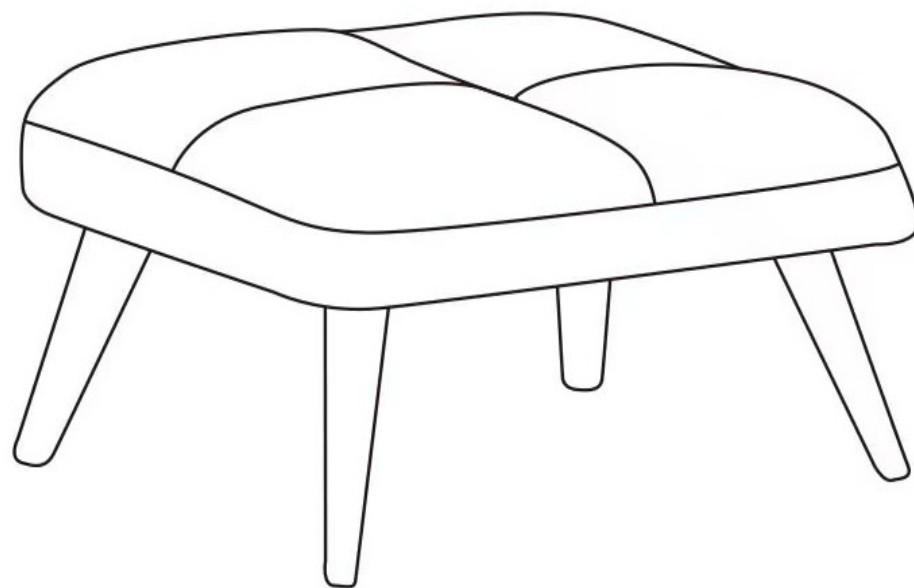

Step 5:

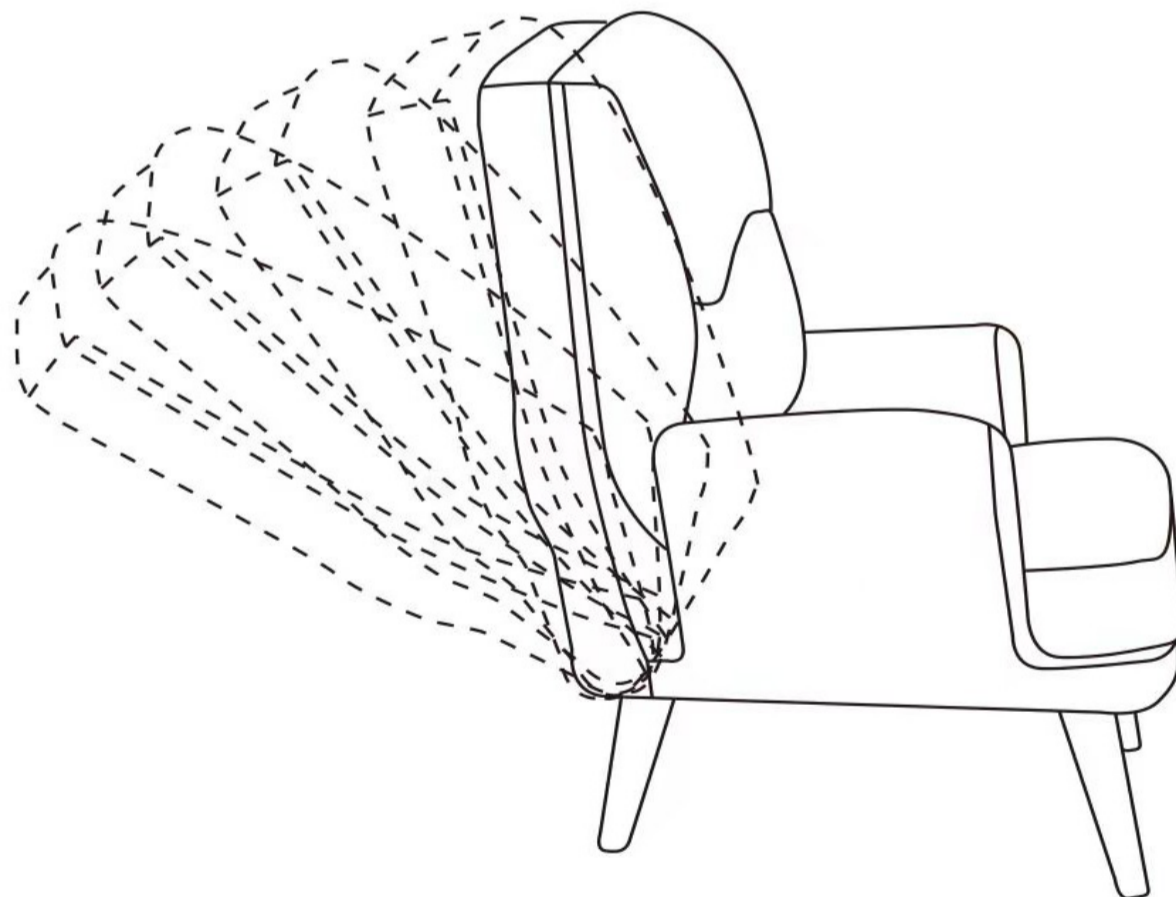
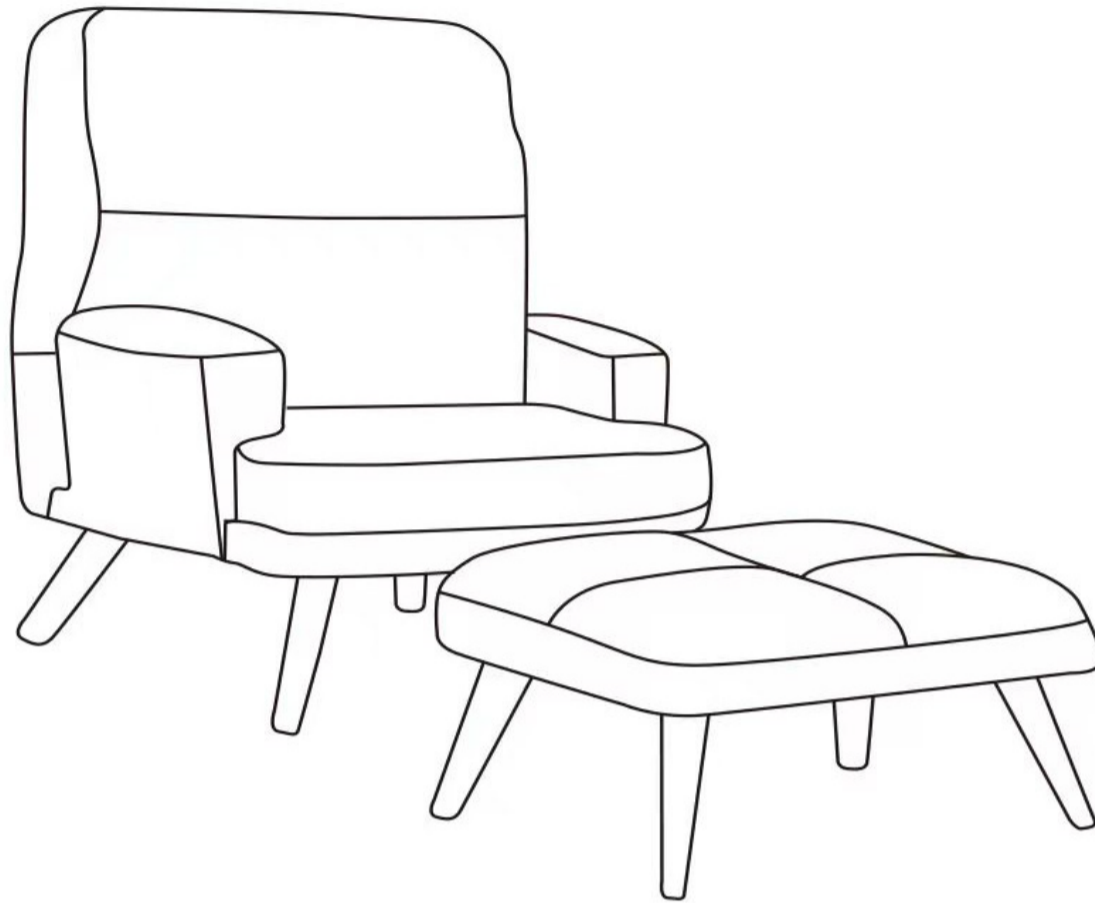

ATTENTION!!

Bolts may loosen during normal everyday use. They should be periodically inspected and re-tightened to prevent damage or injury. Always check to ensure that all hardware is kept tightened.

Warnings

1. Please check if the components of the chair are all included and can be used normally.
2. Assemble all components according to the instruction correctly.
3. If the chair is damaged or doesn't match the website description, please send clear pictures of the product and label of the carton to our service team for further help.
4. If the chair still doesn't assembly, please feed the information back to our customer service in time and we'll help you solve the matter as soon as possible
5. If you have any questions with the product, please contact us by:
Email: customerservice@zoy-living.com (we will reply to you within 24 hours)