

ASSEMBLY INSTRUCTION

ITEM # : WF531505

Thank you for purchasing this quality Product. Be sure to check all packing material carefully for small parts, which may have come loose inside carton during shipment. identify and count all parts and compare with the parts list below.

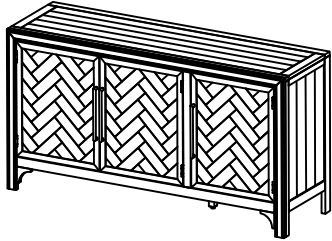





















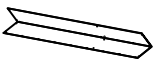





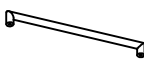

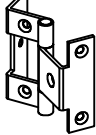
ASSEMBLY INSTRUCTION :

1. Remove hardware from box and sort by size.
2. Please check to see that all hardware and parts are present prior start of assembly.
3. Please follow attached instruction in the same sequence as numbered assure fast and easy assembly.

WARNING !

1. Don't attempt to repair or modify parts that are broken or defective. Please contact the store immediately.
2. This product is for home use only and not intended for commercial establishments.
3. Two persons are required for assembly.
4. Approximate assembly time 1/2 hours.
5. Component parts and fittings contained in the box. Please sort out all parts before you begin to assemble the item. This is to make sure you always use the correct part.
6. It is **STRONGLY RECOMMENDED** that you **ANCHOR** this product. Tying furniture can cause serious injuries and death. To prevent your furniture from tipping forward it is strongly recommended that you securely attach this product to a wall or other solid surface, using the anchor straps provided appropriate fixings.

No.	Component	Q'ty
A	 Top frame	1
B	 Below frame	1
C	 Leg center	1
D	 Left side frame	1
E	 Right side frame	1
F	 Mid side frame	1
G	 Left shelve	1
H	 Right shelve	1
I	 Left door	1
J	 Mid door	1
K	 Right door	1
L	 Front Stretcher	1
M	 Stands Stretcher Front	1
N	 Backs	1

No.	Component	Q'ty
1	 Bolt Ø 6.3x35 mm	15
2	 Spring Washer 6.3x13 mm	15
3	 Flat Washer Ø 6.3 x 18 mm	15
4	 Allen Wrench 4 mm	1
5	 Handles	3
6	 Bulon Ø4 x 25mm	6
7	 Door hinge	6
8	 Lock the upper door	3
9	 Lower door brake	3
10	 Lock the upper door	3
11	 Lower door brake	3
12	 Srews Ø4 x 40 mm	4
13	 Srews Ø4 x 15 mm	30
14	 Srews Ø4 x 15 mm	36
15	 Shelf Pins Ø5.8 mm	8
16	 Srews Ø3 x 12 mm	32
17	 Wooden pegs Ø 8x30 mm	4



not included

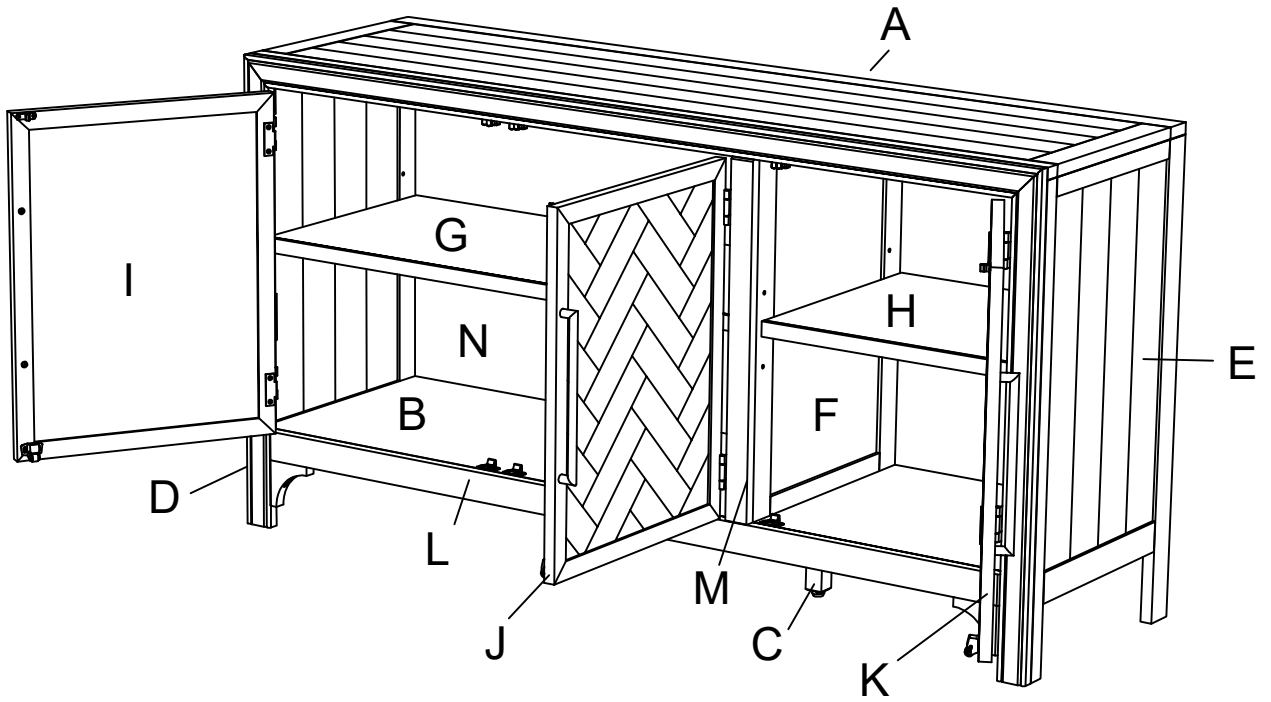



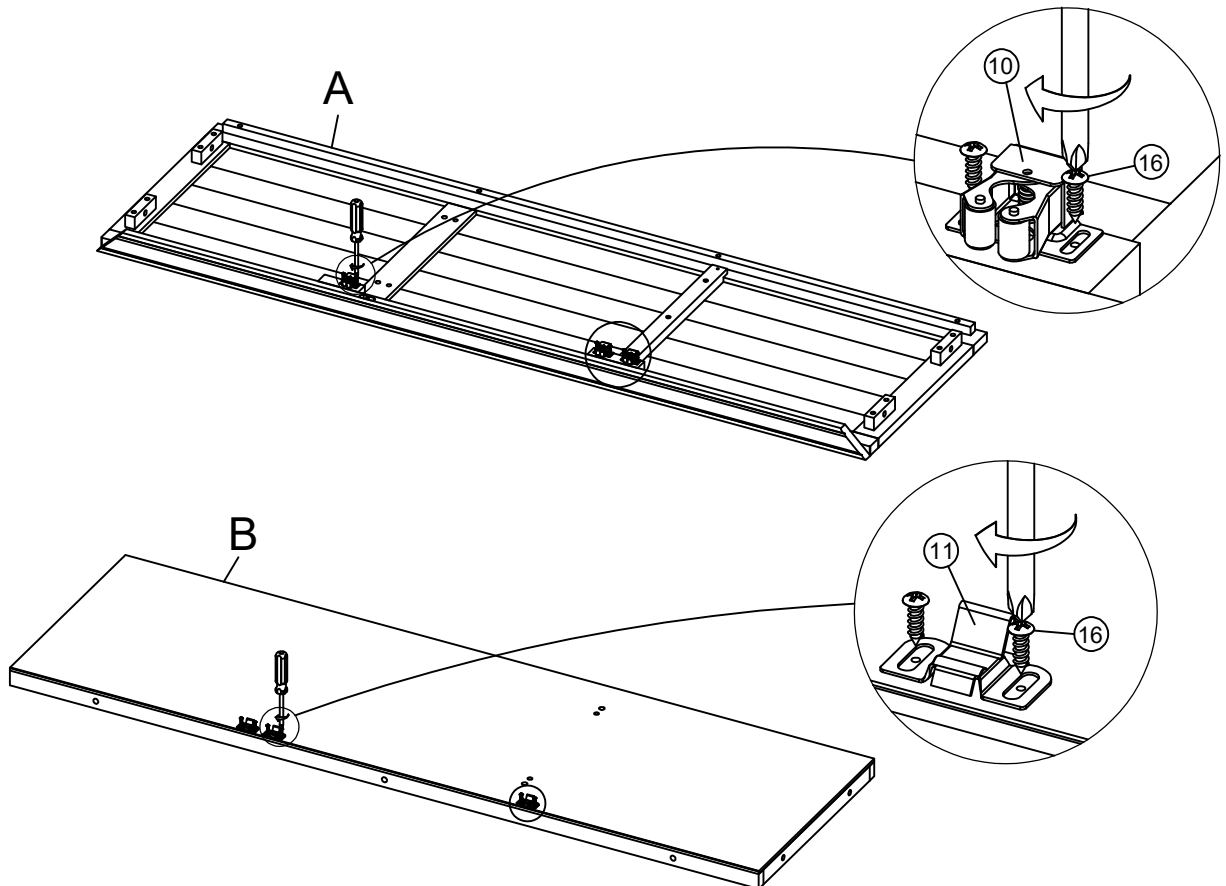

STEP 1

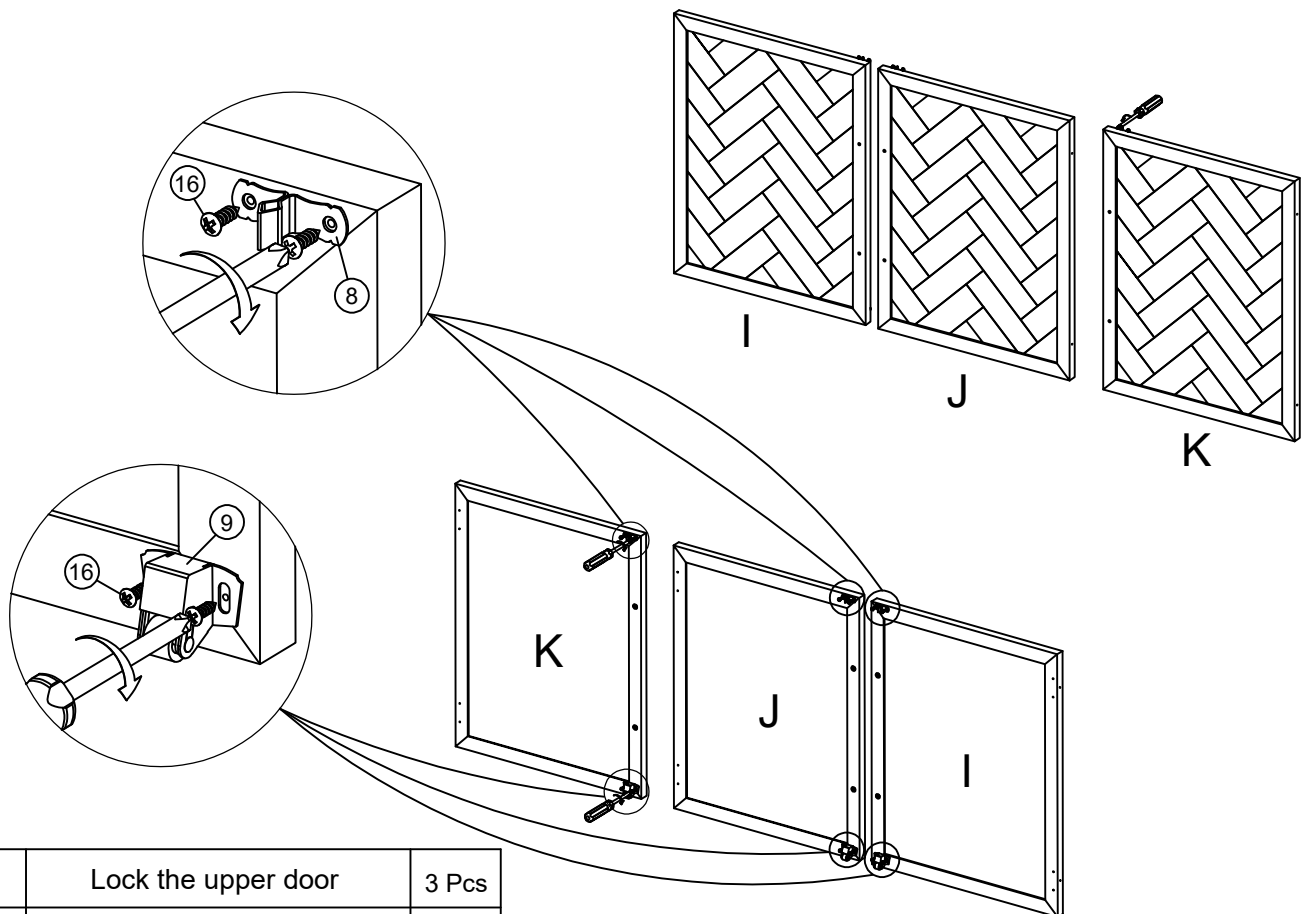

10		Lock the upper door	3 Pcs
11		Lower door brake	3 Pcs
16		Screws Ø3 x 12 mm	12 Pcs



STEP 2

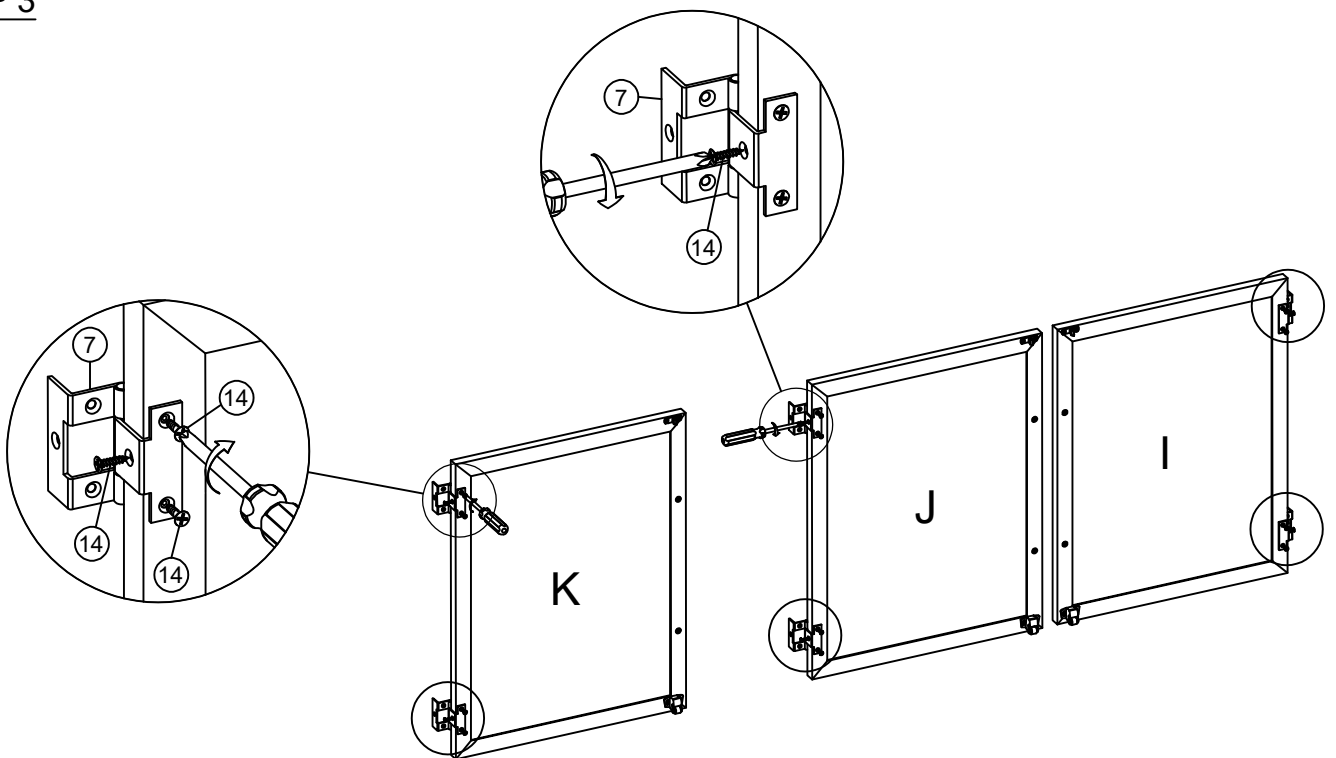

8		Lock the upper door	3 Pcs
9		Lower door brake	3 Pcs
16		Screws $\text{\O}3 \times 12 \text{ mm}$	12 Pcs

STEP 3

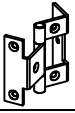

7		Door hinge	6 Pcs
14		Screws $\text{\O}4 \times 15 \text{ mm}$	18 Pcs



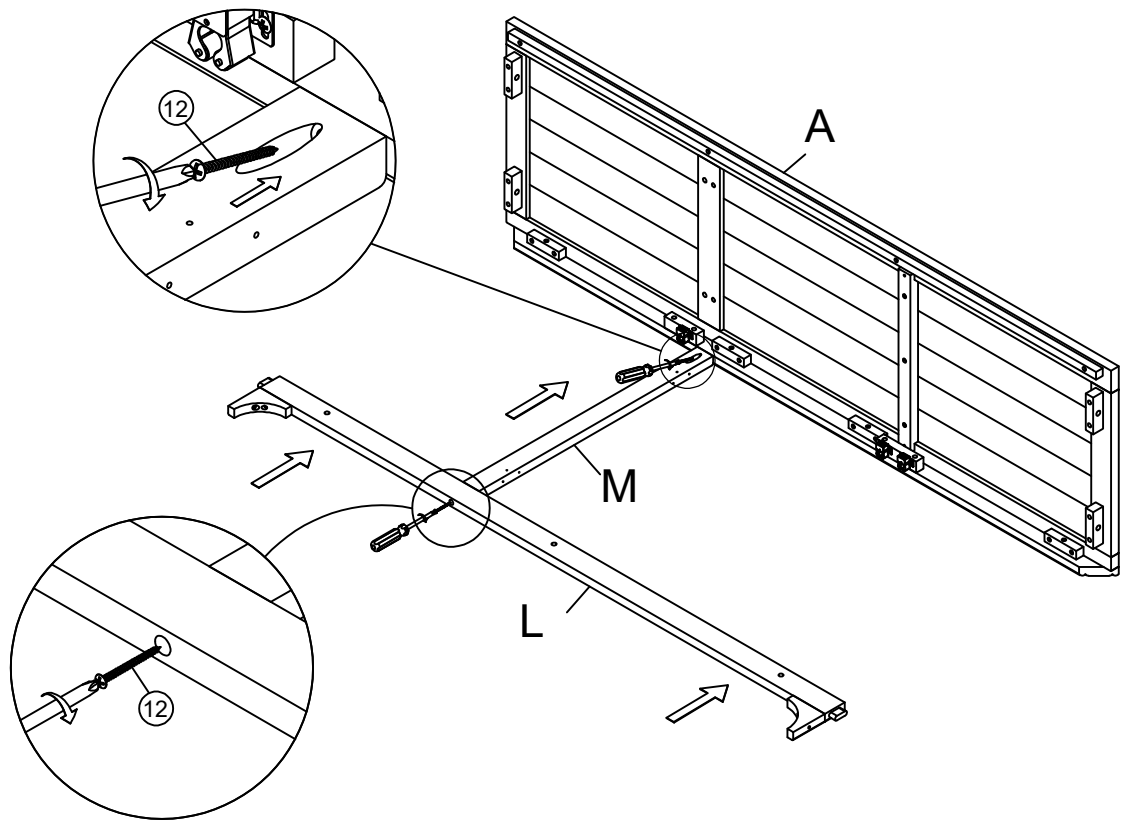

STEP 4

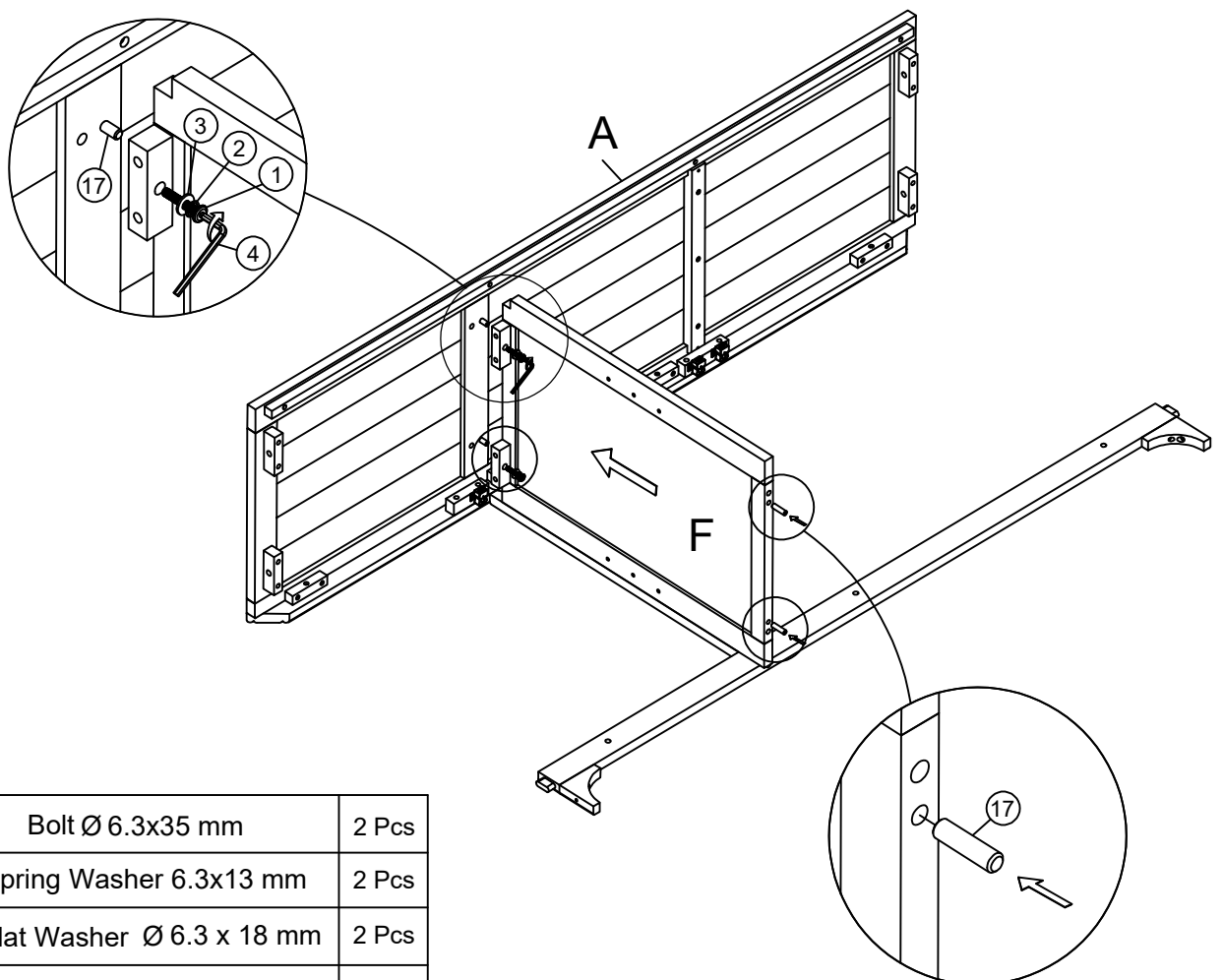

12		Screws $\text{Ø}4 \times 40 \text{ mm}$	2 Pcs
----	---	---	-------





STEP 5

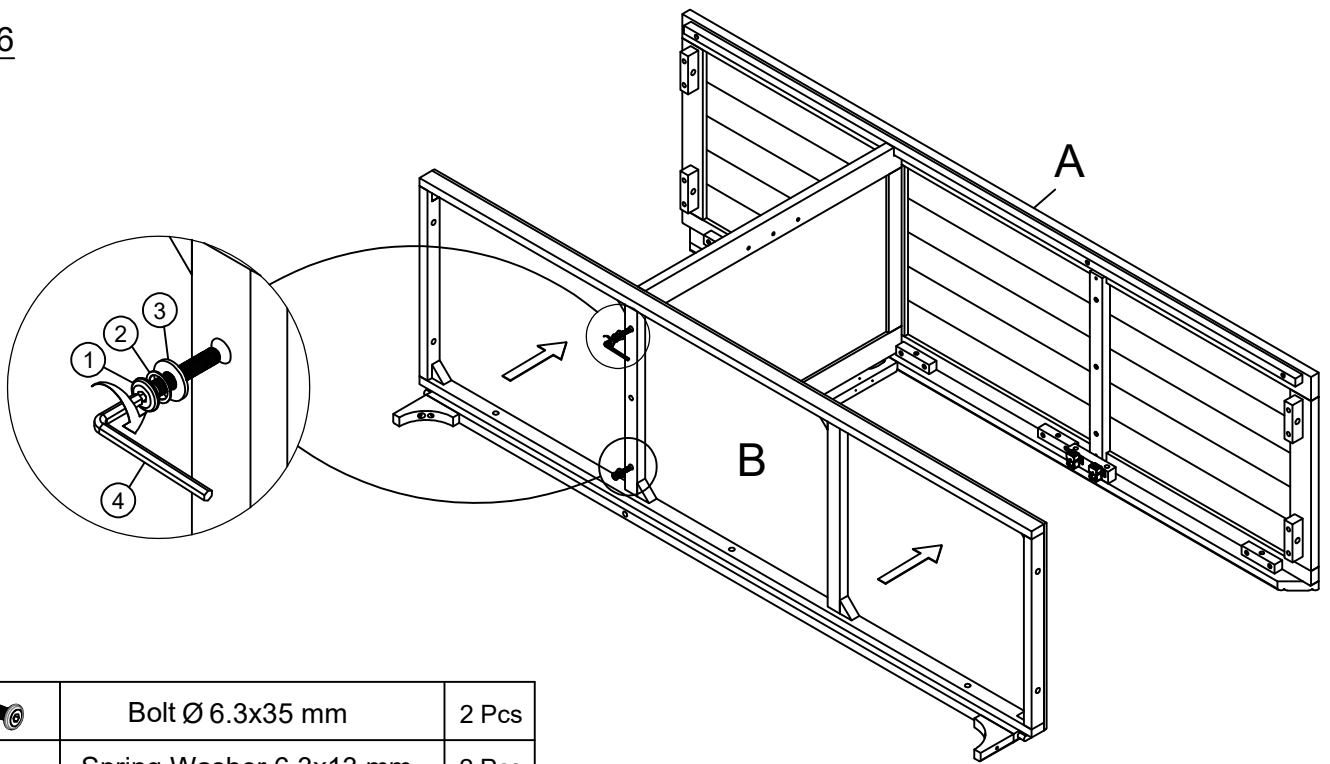

1		Bolt $\text{Ø}6.3 \times 35 \text{ mm}$	2 Pcs
2		Spring Washer $6.3 \times 13 \text{ mm}$	2 Pcs
3		Flat Washer $\text{Ø}6.3 \times 18 \text{ mm}$	2 Pcs
4		Allen Wrench 4 mm	1 Pc
17		Wooden pegs $\text{Ø}8 \times 30 \text{ mm}$	4 Pcs





STEP 6

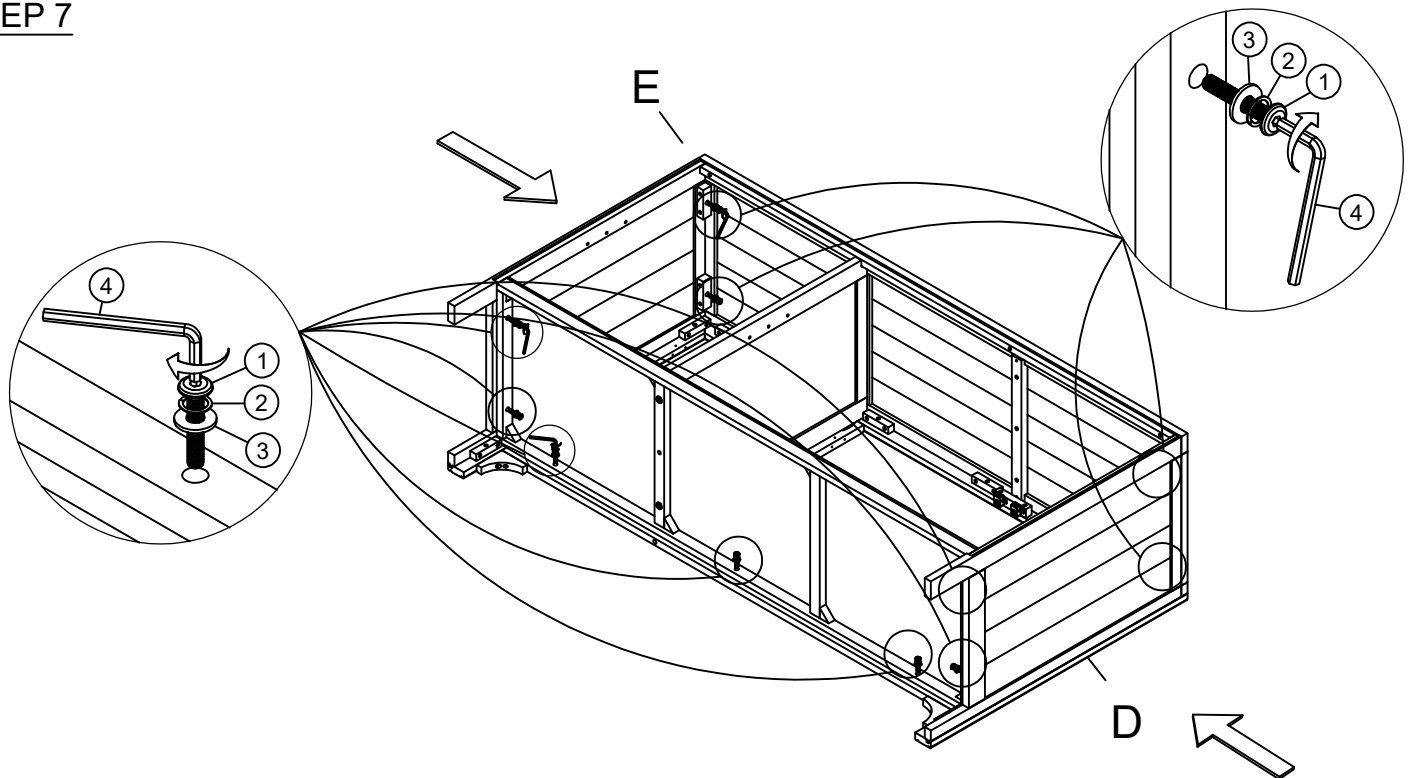

1		Bolt Ø 6.3x35 mm	2 Pcs
2		Spring Washer 6.3x13 mm	2 Pcs
3		Flat Washer Ø 6.3 x 18 mm	2 Pcs
4		Allen Wrench 4 mm	1 Pc

STEP 7



1		Bolt Ø 6.3x35 mm	11 Pcs
2		Spring Washer 6.3x13 mm	11 Pcs
3		Flat Washer Ø 6.3 x 18 mm	11 Pcs
4		Allen Wrench 4 mm	1 Pc

STEP 8

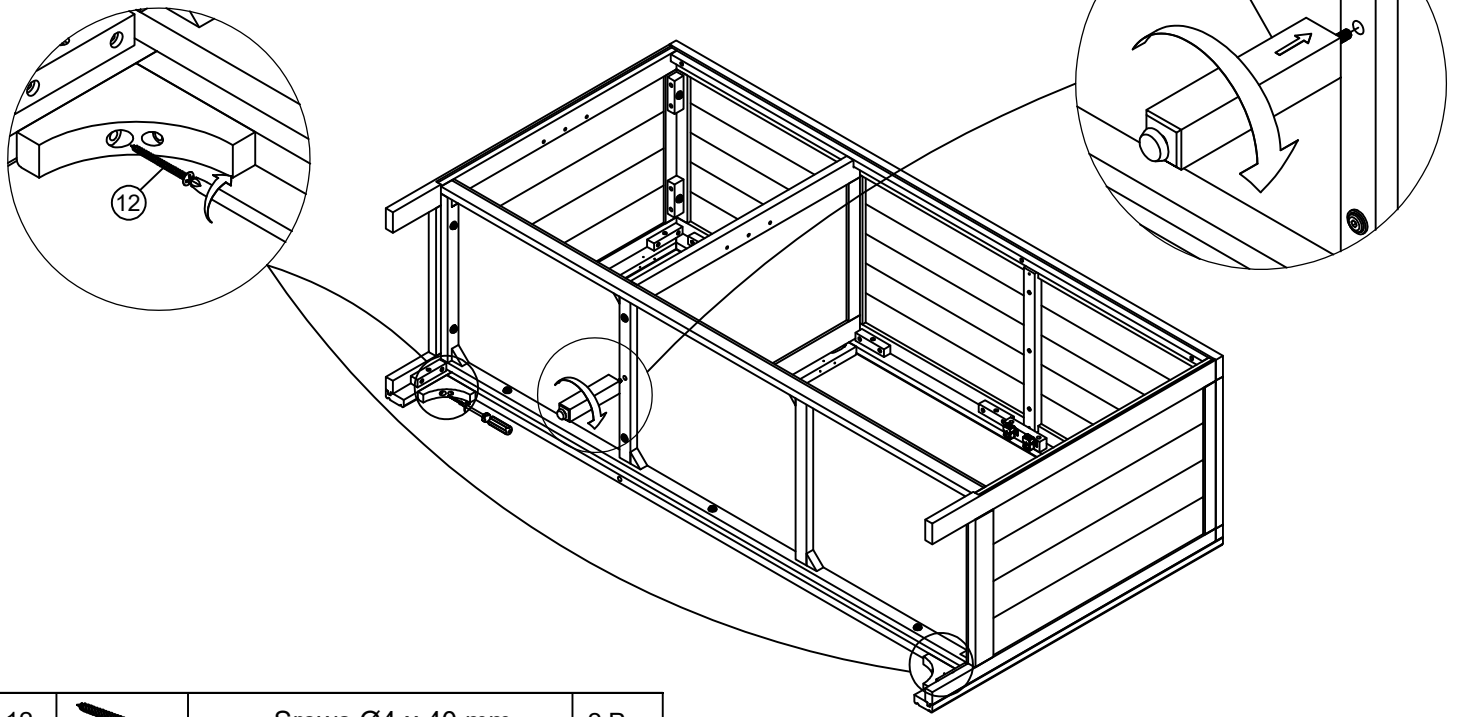

12		Screws $\text{Ø}4 \times 40 \text{ mm}$	2 Pcs
----	---	---	-------

STEP 9

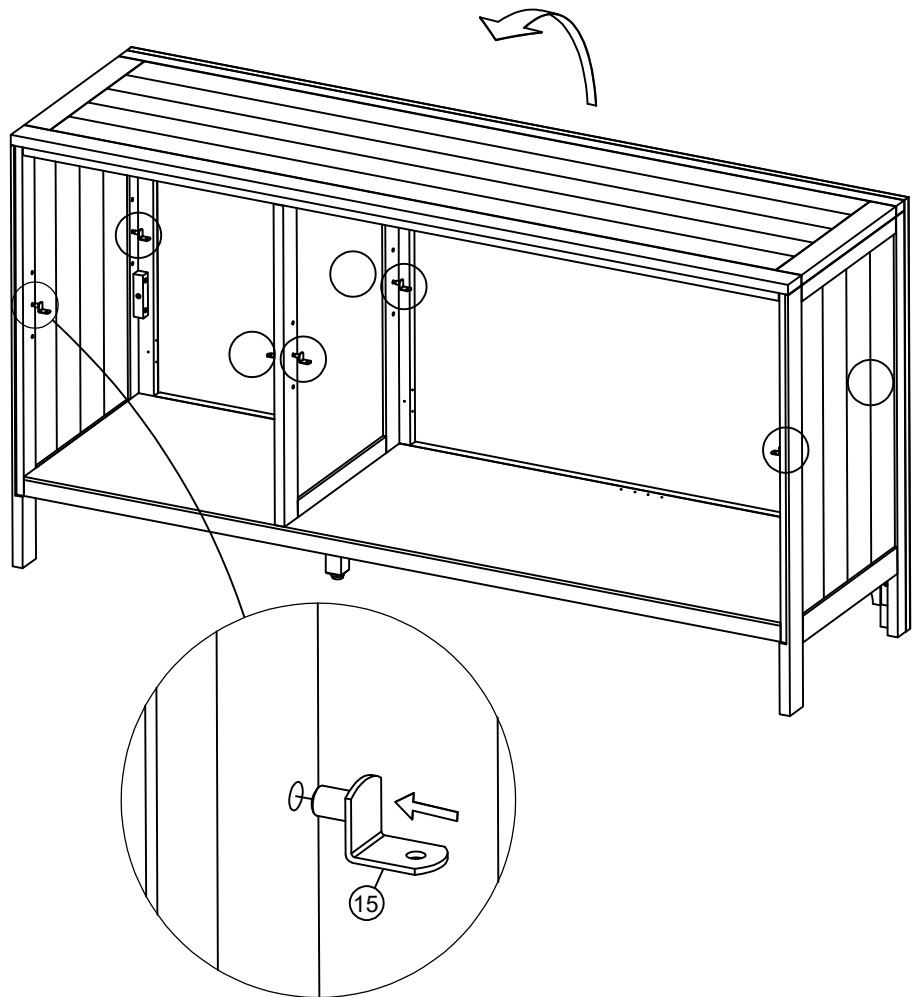

15		Shelf Pins $\text{Ø}5.8 \text{ mm}$	8 Pcs
----	---	-------------------------------------	-------

STEP 10

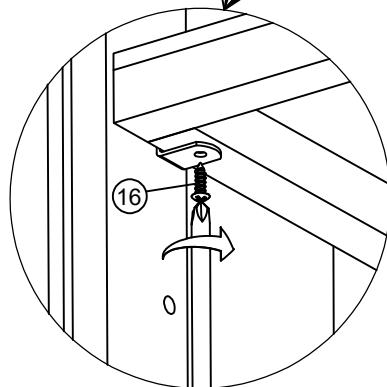
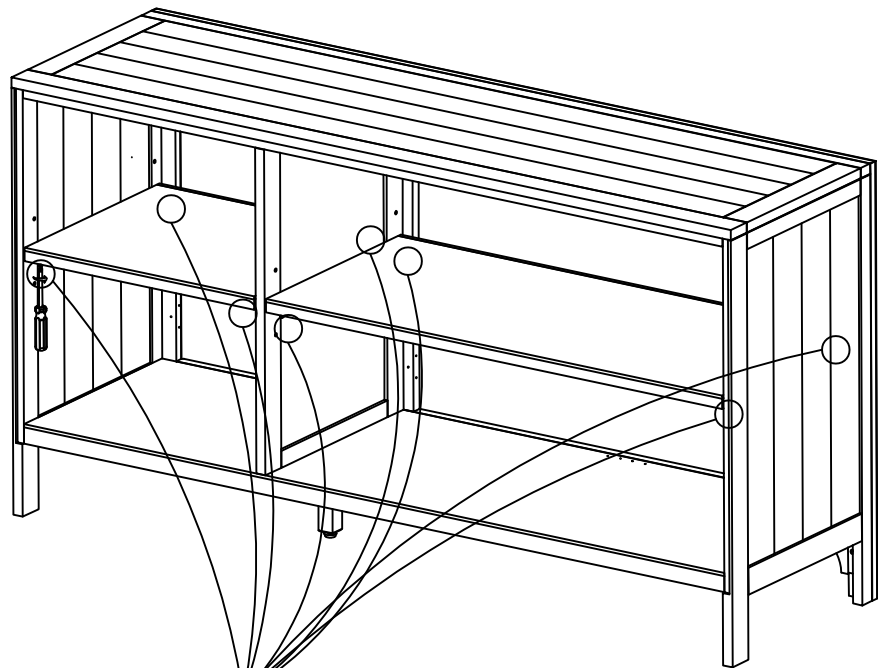
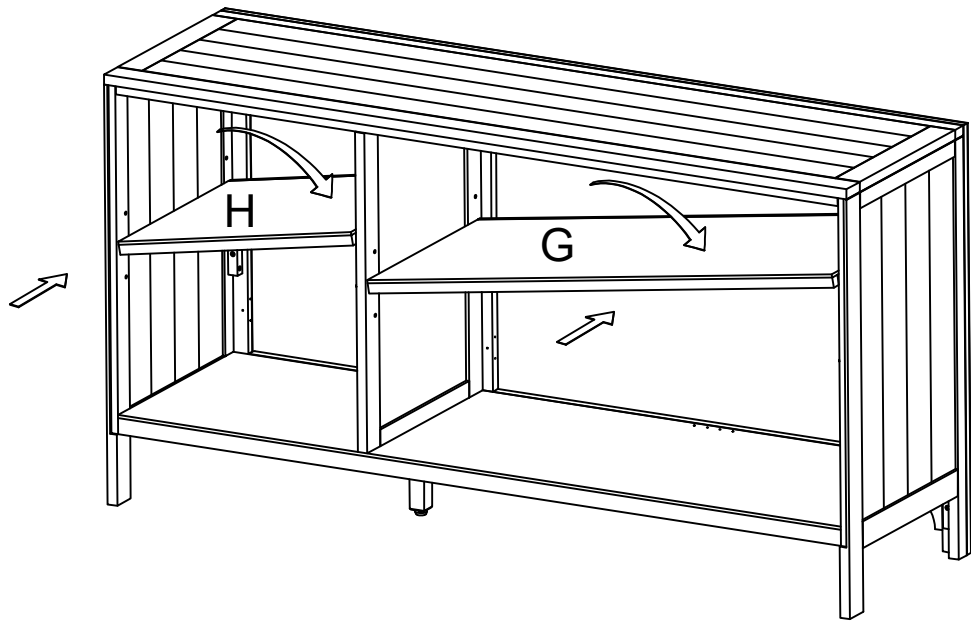

STEP 11

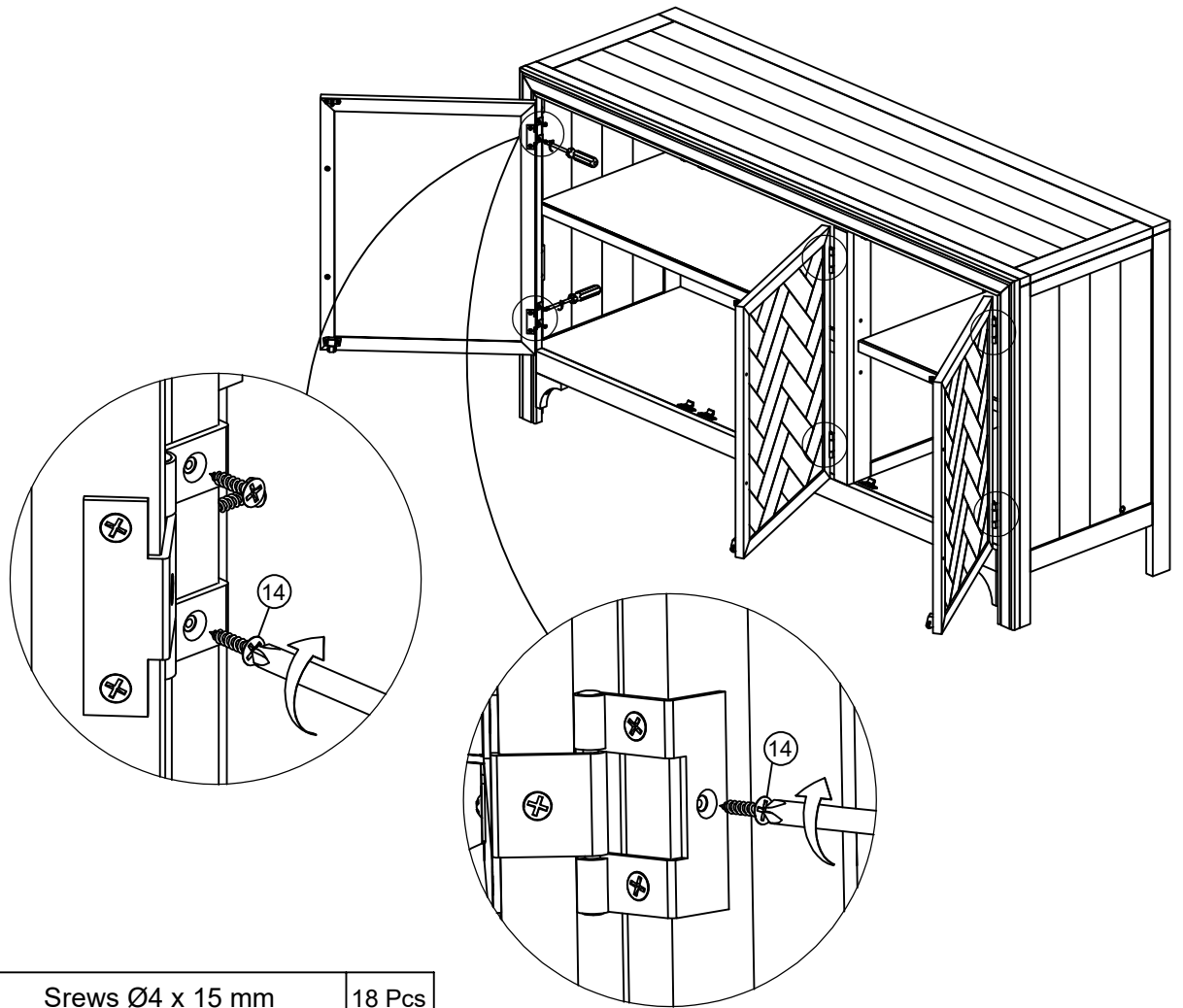

14



Srews Ø4 x 15 mm

18 Pcs

STEP 12

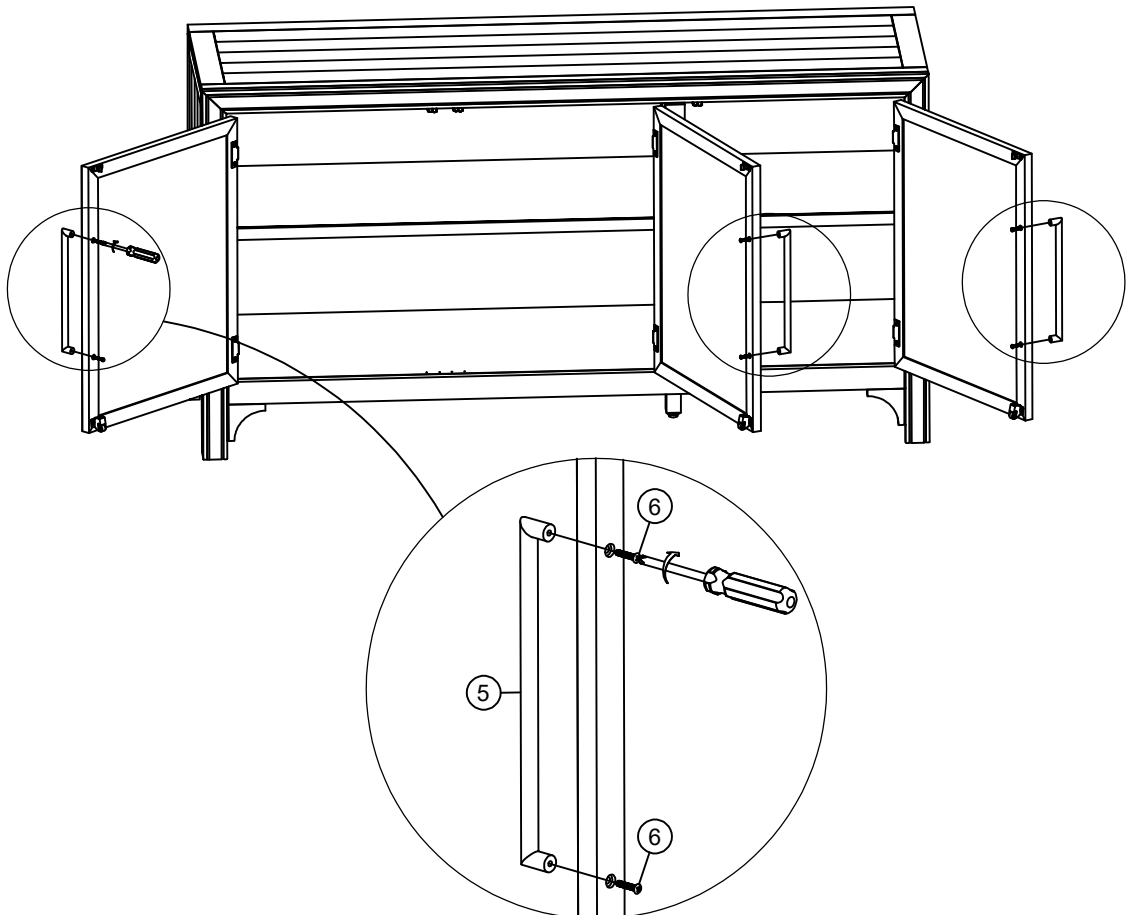

5

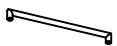

Handles

3 Pcs

6



Bulon Ø4 x 25mm

6 Pcs

STEP 13

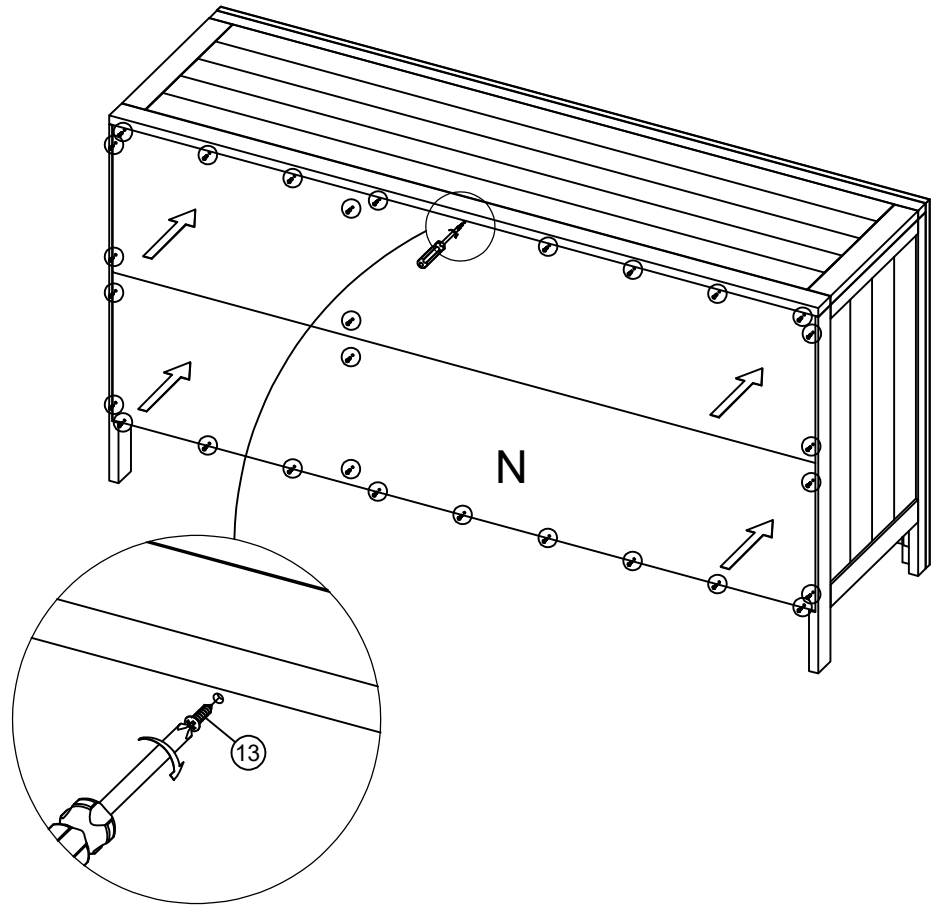

13



Srews $\text{\O}4 \times 15 \text{ mm}$

30 Pcs

STEP 14

