

# ASSEMBLY INSTRUCTIONS

SKU NO. : WF312987

DESCRIPTION : CONSOLE TABLE 4 DRAWERS

## IMPORTANT NOTE

**\*\*PLACE ALL PARTS ON A CLEAN AND SMOOTH SURFACE SUCH AS A RUG OR CARPET TO AVOID THE PARTS FROM BEING SCRATCHED**

**\*\*BEFORE YOU BEGIN, KINDLY FOLLOW THE ASSEMBLY INSTRUCTIONS STEP BY STEP**

**\*\*DO NOT TIGHTEN ALL SCREWS AND BOLTS UNTIL THE CABINET IS FULLY SET-UP**

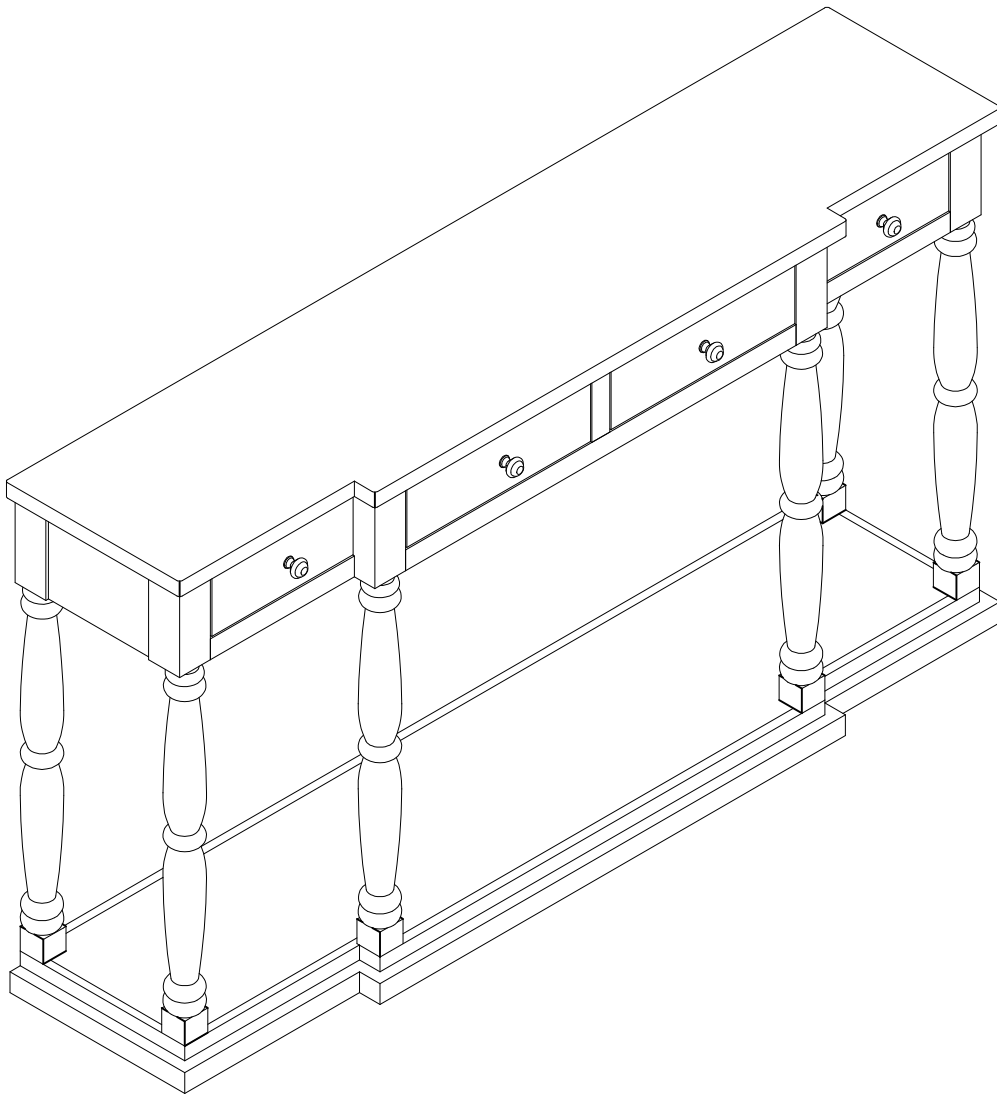





**PLEASE DO NOT RETURN PRODUCT TO THE STORE**

# ASSEMBLY INSTRUCTIONS

SKU NO. : WF312987

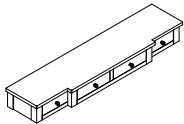
DESCRIPTION : CONSOLE TABLE 4 DRAWERS

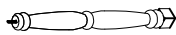
## CARTONS ONLY ONE / HARDWARE LIST

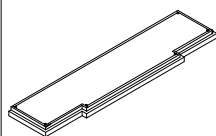
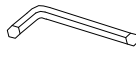
PART LISTS				HARDWARE LIST			
NO	DESCRIPTION	SKETCH	Q'TY	NO	DESCRIPTION	SKETCH	Q'TY
A	TOP TABLE		1 PC	1	BOLT Ø1/4*50mm		6 PCS
				2	WASHER Ø1/4*19mm		6 PCS
B	LEGS		6 PCS	3	SPRING WASHER Ø1/4"*11mm		6 PCS
C	TABLE BASE		1 PC	4	ALLEN KEY M4*60mm		1 PC

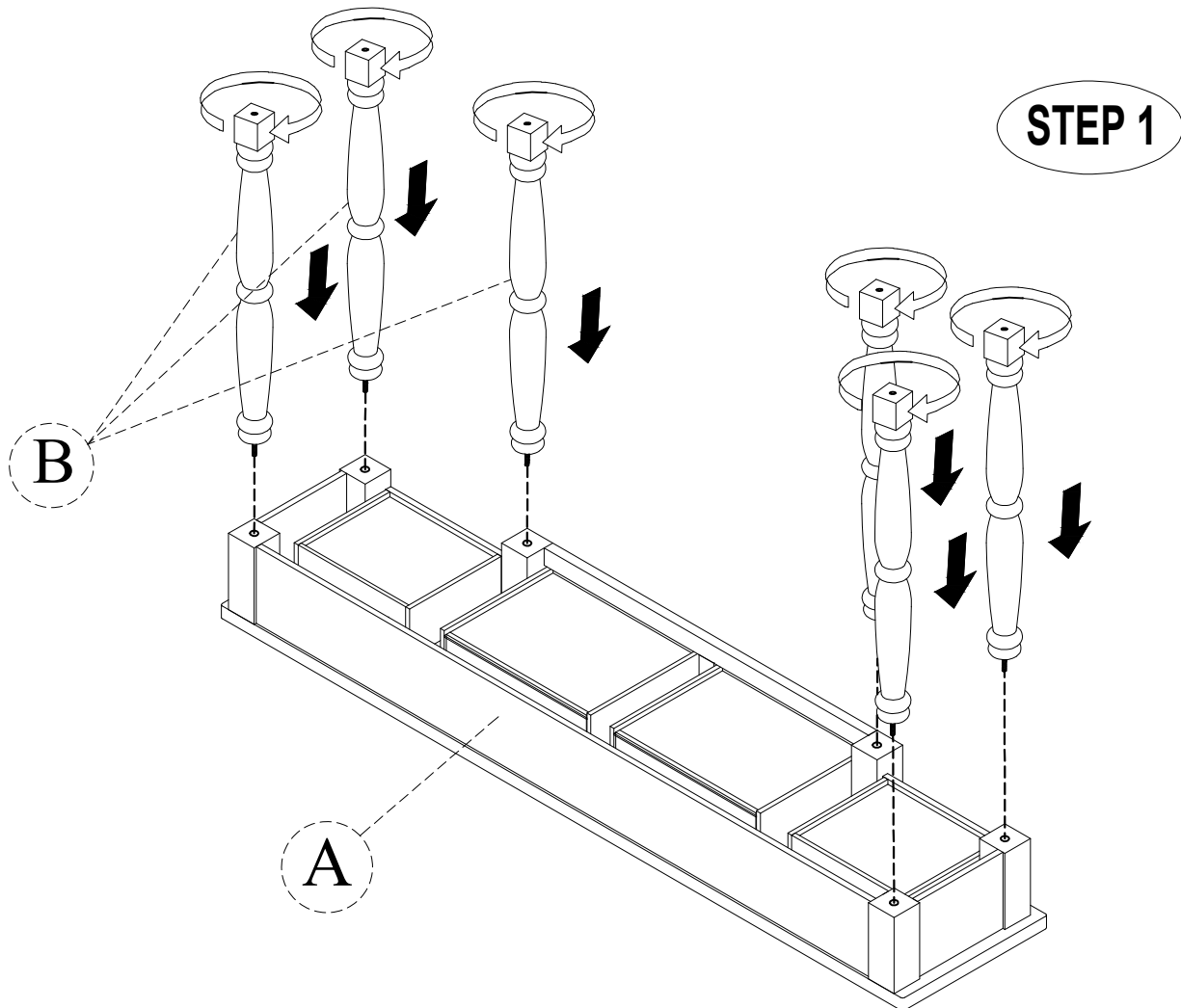

# ASSEMBLY INSTRUCTIONS

SKU NO. : WF312987

DESCRIPTION : CONSOLE TABLE 4 DRAWERS

**STEP 2**

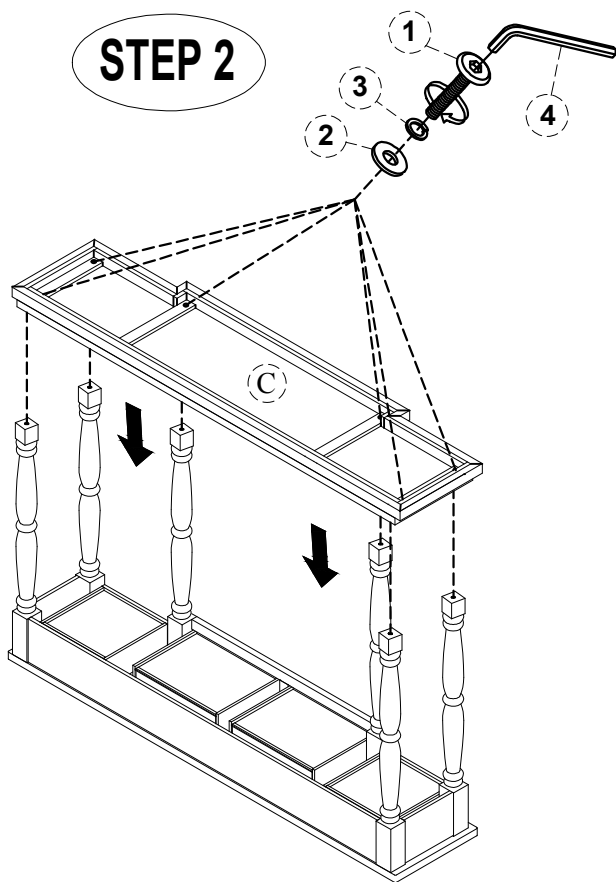

**STEP 3**

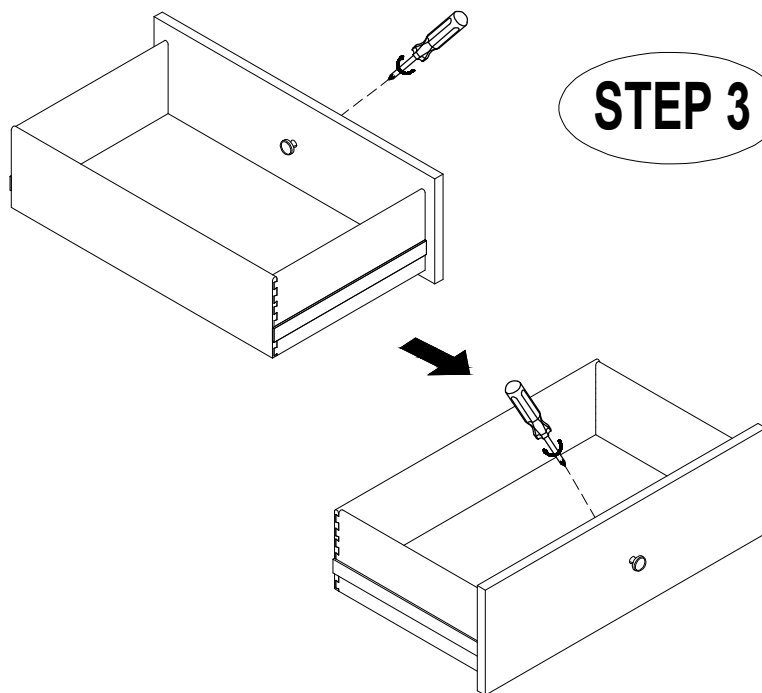

**COMPLETE**

