

7078B/7078B-1/7078B-2

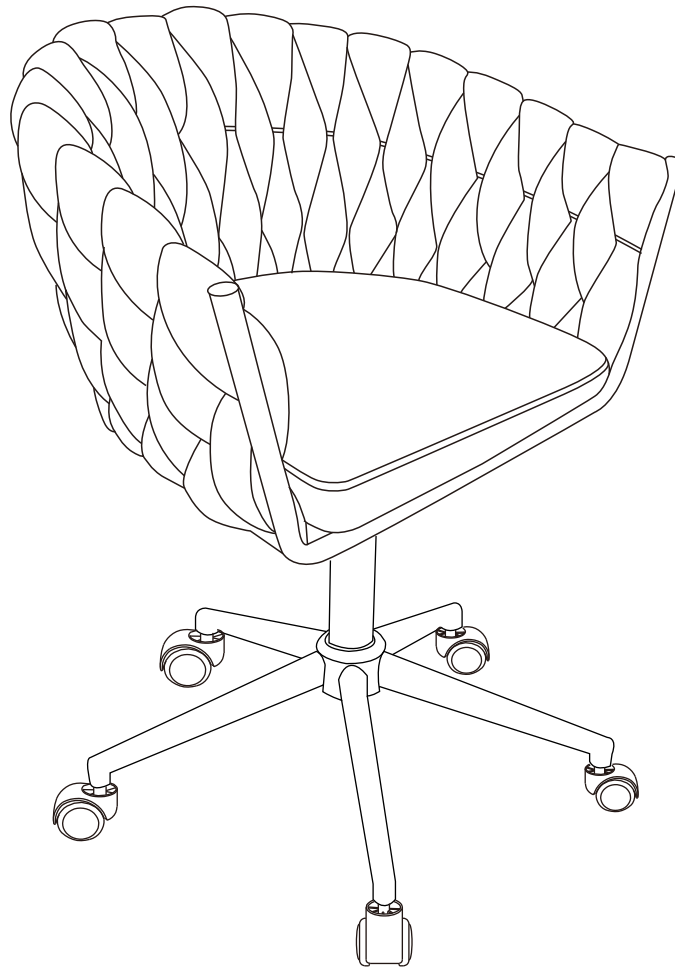

As this item contains many parts, please read the installation instruction carefully before installation . Please use tools properly and carefully. If you have any questions about the product and installation, please contact us.

admin@ajyshoming.com

Our professional after-sales team will serve you online all day.

Before You Start

- ✓ Read through each step carefully and follow the proper order
 - ✓ Separate and count all your parts and hardware
 - ✓ Give yourself enough room for the assembly process
 - ✓ Have the following tools: Allen Wrench
 - ✓ Caution: If using a power drill or power screwdriver for screwing, please be aware of to slow down and stop when screw is tight. Failure to do so may result in stripping the screw. (Assembly speed can be increased by using electric screwdriver)
- 

Helpful Hints

PEOPLE NEEDED FOR ASSEMBLY: 1-2

- Open your item in the area you plan to keep it to avoid excessive heavy lifting.
- Identify, sort and count the parts before attempting assembly.
- Do NOT use harsh chemicals or abrasive cleaners on this item.
- Never push, pull, or drag your furniture.



Part List

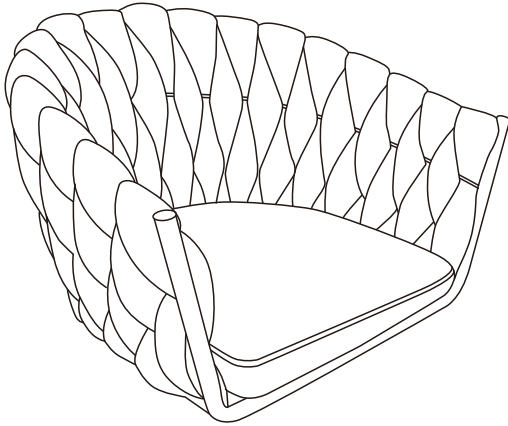

Ⓐ SEAT
QTY:1

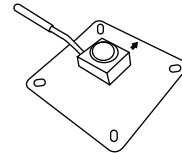

Ⓑ MECHANISM
QTY:1

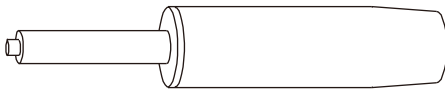

Ⓒ GAS LIFT
QTY:1

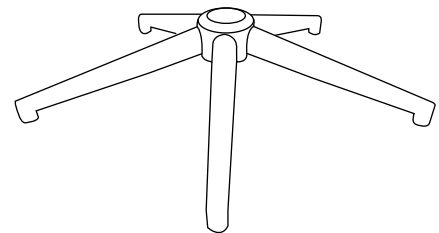

Ⓓ BASE
QTY:1



Ⓔ CASTER
QTY:5

Part List

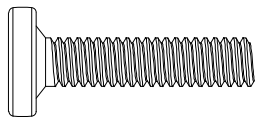

M6X16mm

①

X4

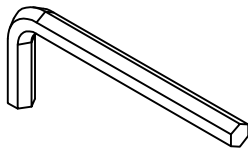

②

X1

STEP 1

Press the casters(E) in to the holes at the end of each leg of the base(D).
Insert the bottom end of the gas lift(C) into the center hole of the base(D).

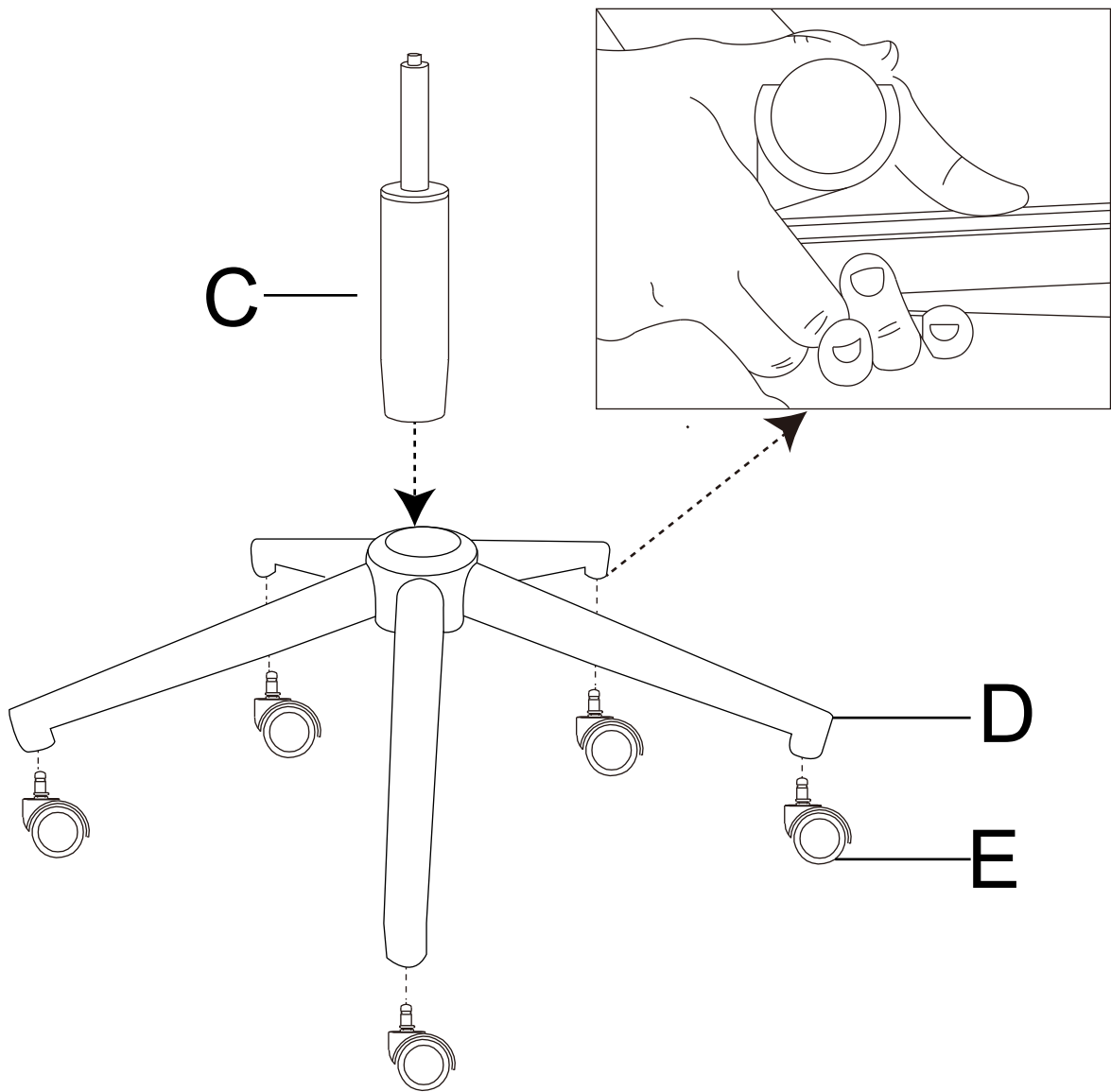

Attach mechanism(B) to the seat(A) with bolts (1) and Allen wrench(2). Don't screw 100% until all of them are right in the holes so that you can adjust slightly during the process of assembly.

STEP2

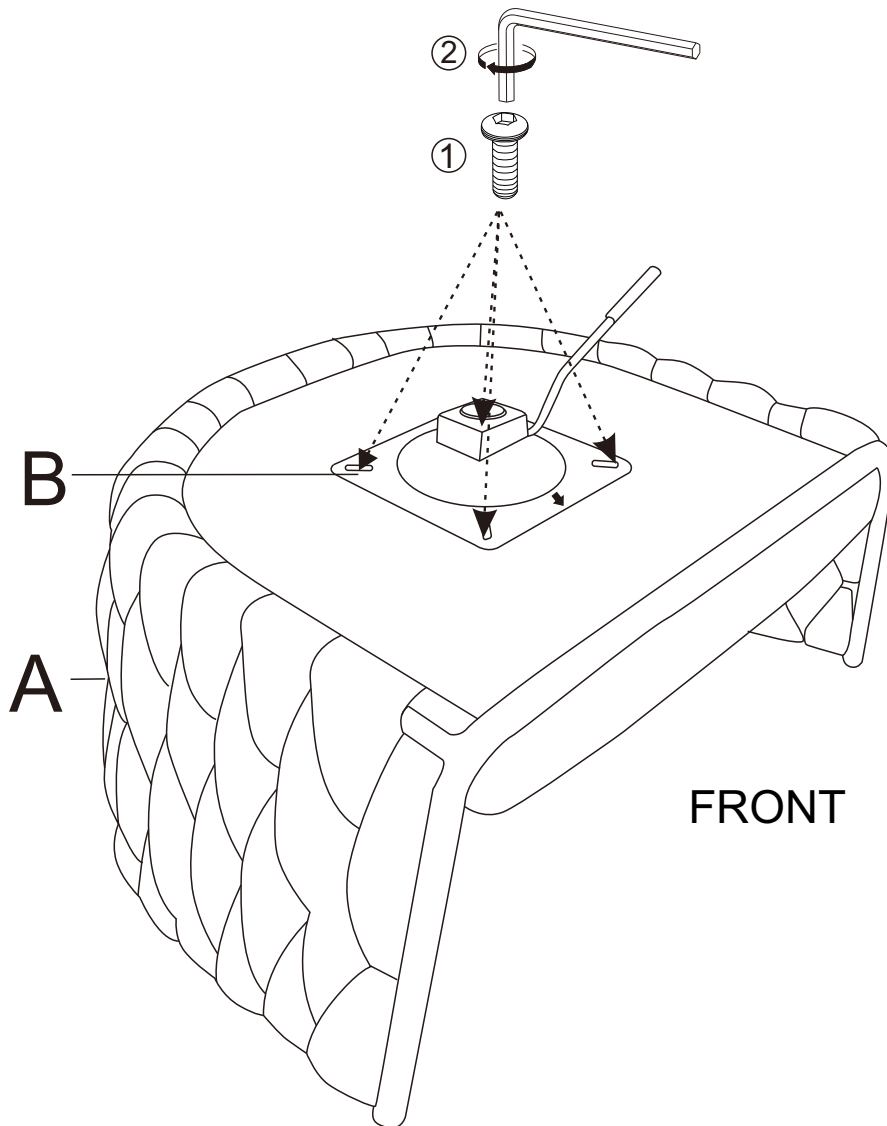
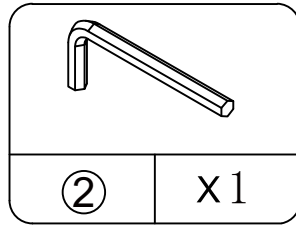
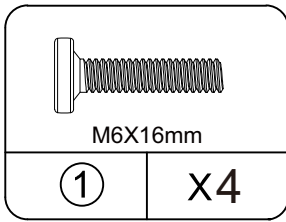

STEP 3 Now turn the assembled seat upright and locate the center hole of the mechanism over the gas lift. Push down firmly until the connection is secure.

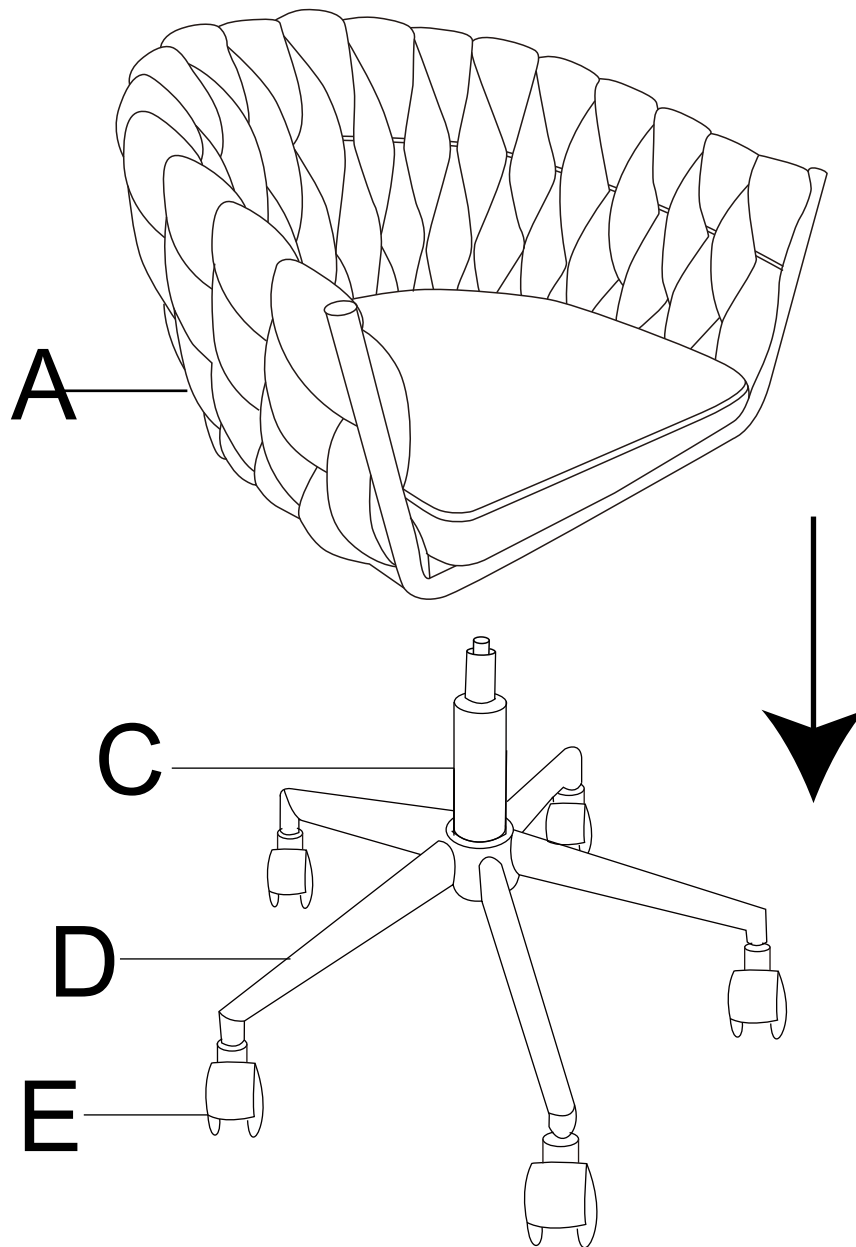

STEP4

Assembly completed.

