

ASSEMBLY INSTRUCTION

SKU CODE: (WF531768-WF531769)

This set is included 2 boxes if don't receive full 2 boxes please contact our customer service team



! SAFETY WARNINGS !

1. This bed is designed for use only mattress (es) meeting the following specifications on the upper bunk







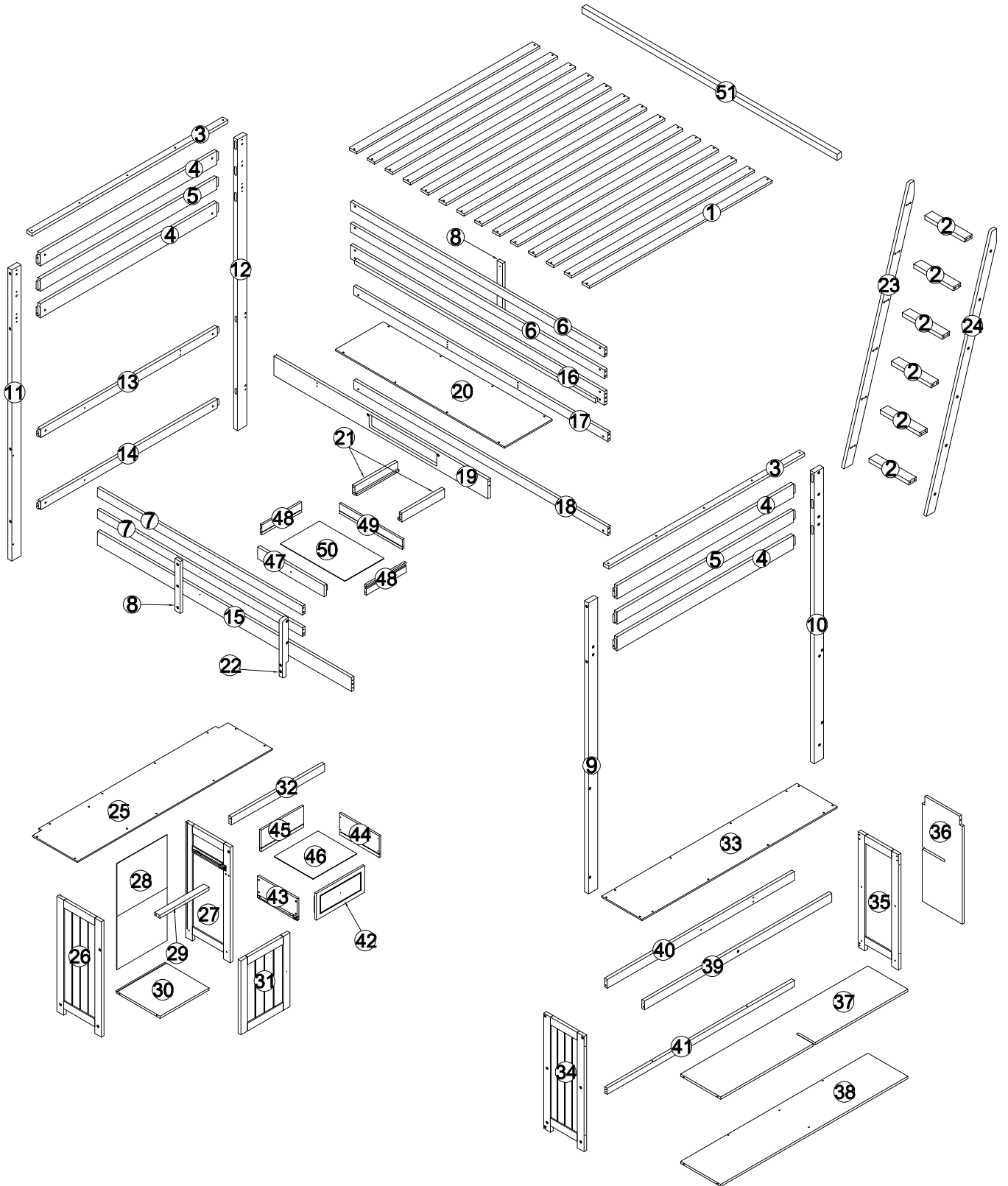

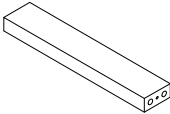
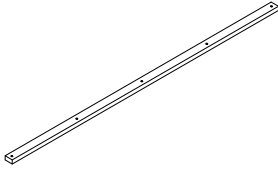
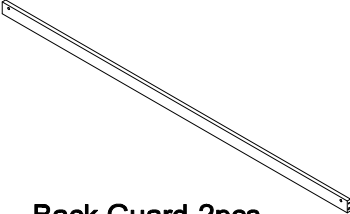
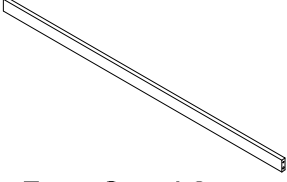

Upper bed Bed Type	Length	Width	Thickness
Full Standard	74" - 75"	53 1/2"	6" max

2. Replacement parts, including additional guardrails, maybe obtained from any of our (GIGACLOUD TECHNOLOGY (USA) INC. 18961 ARENTH AVENUE CITY OF INDUSTRY, CA, 91748) dealers
3. Follow the information on the warnings appearing on the upper bunk bed end structure and on the carton. Do not remove warning label from bed
4. Always use the recommended size mattresses or mattress supports, or both, to help prevent the likelihood of entrapment or falls.
5. Surface of mattress must be at least 5" (127mm) below the upper edge of guardrails
6. Do not allow children under 6 years of age to use the upper bunk.
7. Periodically check and ensure that the guardrail, ladder, and other components are in their proper position, free from damage, and that all connectors are tight.
8. Do not allow horseplay on or under the bed and prohibit jumping on the bed.
9. Always use the ladder for entering and leaving the upper bunk
10. Do not use substitute part. Contact the manufacture or dealer for replacement part
11. Use of a night light may provide added safety precaution for a child using the upper bunk..
12. Always use guardrails on both long sides of the upper bunk. If the bunk bed will be placed next to the wall, the guardrail that runs the full length of the bed should be placed against the wall to prevent entrapment between the bed and wall.
13. The use of water or sleep flotation mattresses is prohibited
14. STRANGULATION HAZARD - Never attach or hang items to any part of the bunk bed that are not designed for use with the bed; for example, but not limited to, hook, belts and jump ropes
15. Keep these instruction for future reference
16. Prohibit more than one person on upper bunk
17. We recommend assembling your bunk bed on the shipping carton to protect your floor or carpet
18. Be certain all staples are out of the box before beginning assembly on the shipping carton.

ASSEMBLY INSTRUCTION

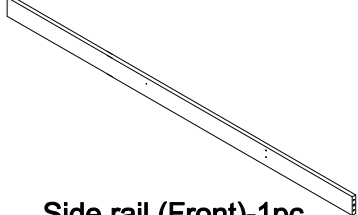
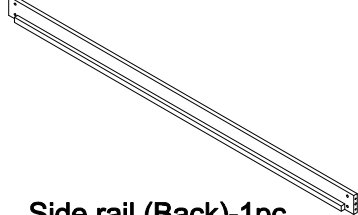
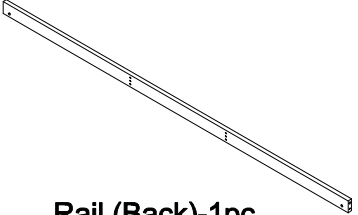
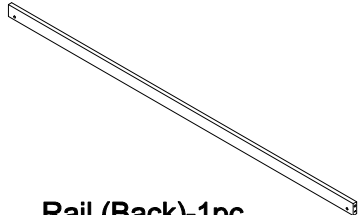
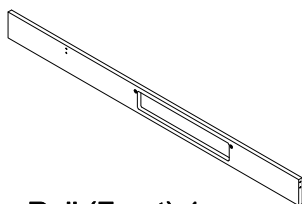
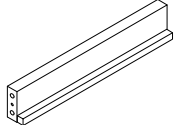

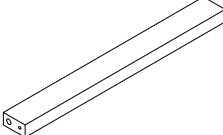
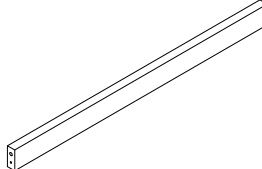
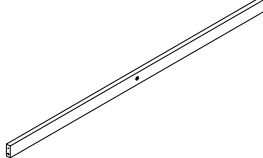

Part List (Box 1-WF531768)

<p>2</p>  <p>Step Ladder-6pcs</p>	<p>3</p>  <p>Top Rails-2pcs</p>	<p>6</p>  <p>Back Guard-2pcs</p>
<p>7</p>  <p>Front Guard-2pcs</p>	<p>8</p>  <p>Rails-2pcs</p>	<p>9</p>  <p>Leg-1pc</p>
<p>10</p>  <p>Leg-1pc</p>	<p>11</p>  <p>Leg-1pc</p>	<p>12</p>  <p>Leg-1pc</p>
<p>15</p>  <p>Side rail (Front)-1pc</p>	<p>16</p>  <p>Side rail (Back)-1pc</p>	<p>17</p>  <p>Rail (Back)-1pc</p>
<p>18</p>  <p>Rail (Back)-1pc</p>	<p>19</p>  <p>Rail (Front)-1pc</p>	<p>21</p>  <p>Rails-2pcs</p>
<p>22</p>  <p>Handle-1pc</p>	<p>23</p>  <p>Side Ladder-1pc</p>	<p>24</p>  <p>Side Ladder-1pc</p>
<p>29</p>  <p>Rail Cabinet-1pc</p>	<p>32</p>  <p>Rail Cabinet-1pc</p>	<p>39</p>  <p>Wood Bar (shelf)-1pc</p>

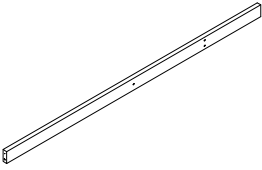
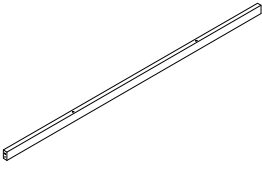
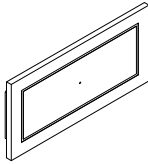
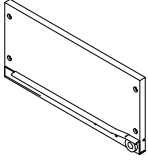
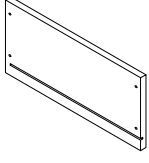
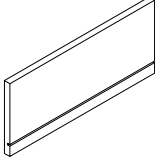
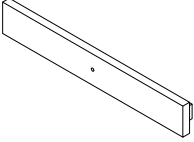
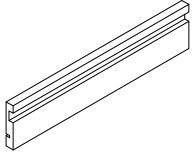
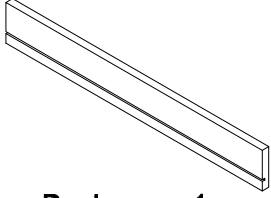
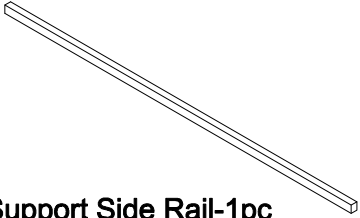



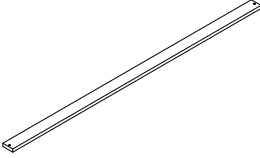
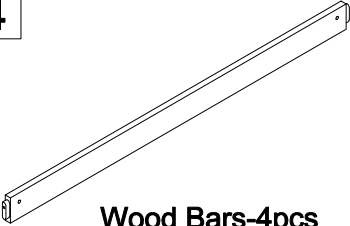
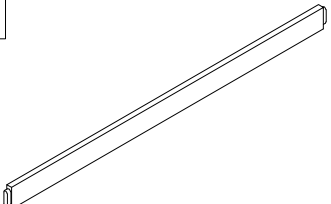
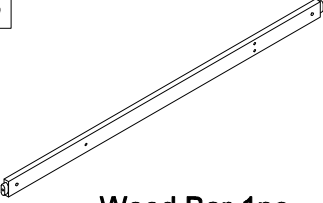

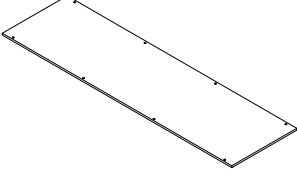
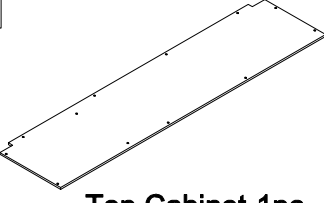
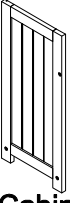
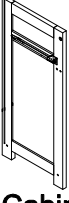
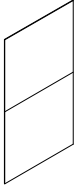
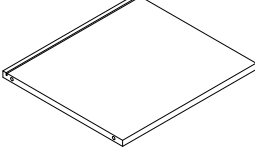
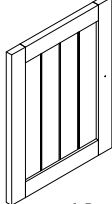
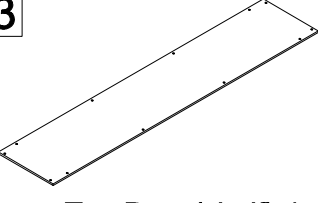
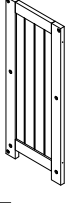
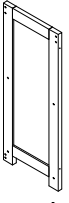
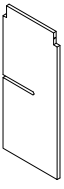
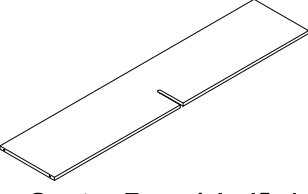
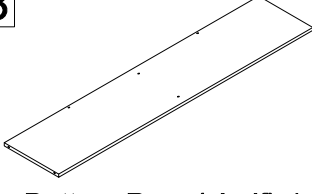
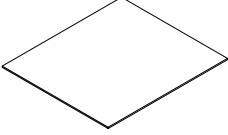
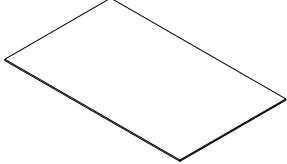

Part List (Box 1-WF531768)

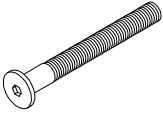
40  Wood Bar (shelf)-1pc	41  Wood Bar (shelf)-1pc	42  Drawer-Front pane-1pc
43  Drawer-Side pane-1pc	44  Drawer-Side pane-1pc	45  Drawer-Back pane-1pc
47  Drawer-Front pane-1pc	48  Drawer-Side panes-2pcs	49  Drawer-Back pane-1pc
51  Support Side Rail-1pc		

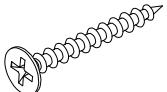
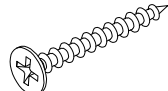
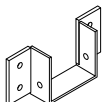
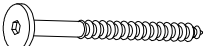
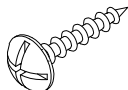
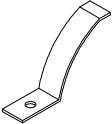
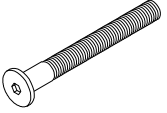
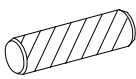
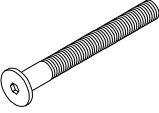
Part List & Hardware List (Box 2-WF531769)

<p>1</p>  <p>Slats-14pcs</p>	<p>4</p>  <p>Wood Bars-4pcs</p>	<p>5</p>  <p>Wood Bars-2pcs</p>
<p>13</p>  <p>Wood Bar-1pc</p>	<p>14</p>  <p>Wood Bar-1pc</p>	<p>20</p>  <p>Top Table-1pc</p>
<p>25</p>  <p>Top Cabinet-1pc</p>	<p>26</p>  <p>Side Cabinet-1pc</p>	<p>27</p>  <p>Side Cabinet-1pc</p>
<p>28</p>  <p>Back Cabinet-1pc</p>	<p>30</p>  <p>Bottom Cabinet-1pc</p>	<p>31</p>  <p>Door Frame (Cabinet)-1pc</p>
<p>33</p>  <p>Top Pane(shelf)-1pc</p>	<p>34</p>  <p>Side Frame(shelf)-1pc</p>	<p>35</p>  <p>Side Frame(shelf)-1pc</p>
<p>36</p>  <p>Center Pane(shelf)-1pc</p>	<p>37</p>  <p>Center Pane(shelf)-1pc</p>	<p>38</p>  <p>Bottom Pane(shelf)-1pc</p>
<p>46</p>  <p>Drawer-Bottom pane-1pc</p>	<p>50</p>  <p>Drawer-Bottom pane-1pc</p>	

Hardware List(Box 2-WF531769)

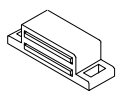
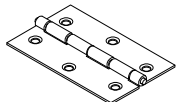
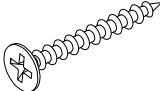
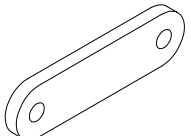
<p>A</p>  <p>Screws 1/4" x110 12pcs</p>	<p>B</p>  <p>Ø1/4" x 13 mm Horizontal-Hole bolts 48pcs</p>	<p>C</p>  <p>M4 x 30 mm Wood Screws 50pcs</p>
<p>D</p>  <p>M4 x 20 mm Wood Screws 46pcs</p>	<p>E</p>  <p>Steel Bracket 2pc</p>	<p>F</p>  <p>Screws 1/4" x30 8pcs</p>
<p>G</p>  <p>M4 x 15 mm Wood Screws 4pcs</p>	<p>H</p>  <p>Stop Drawer(Plastic) 2pcs</p>	<p>K</p>  <p>Screws 1/4" x80 18pcs</p>
<p>L</p>  <p>Ø10 x 40 mm Wood dowel 56pcs</p>	<p>M</p>  <p>Screws 1/4" x70 6pcs</p>	<p>N</p>  <p>Ø1/4" x 35 mm Hex-Head bolts 18pcs</p>
<p>P</p>  <p>Ø1/4" x 15 mm Canopy head though -2pcs</p>	<p>Q</p>  <p>Screws 1/4" x50 18pcs</p>	<p>R</p>  <p>Screws 1/4" x60 6pcs</p>
<p>S</p>  <p>Ø1/6" x 25 mm Hex-Head bolts 3pcs</p>	<p>T</p>  <p>Handle Wood 3pcs</p>	<p>U</p>  <p>Door Catches(45x17x13) 1pc</p>
<p>X</p>  <p>Leaf hinge 2pcs</p>	<p>Y</p>  <p>M3 x 12 mm Wood Screws 16pcs</p>	<p>Z</p>  <p>Magnet Inhaler -1pc</p>

Hardware List(Box 2-WF531769)

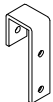
O  Bracket 2pcs	W  Allen Key 1pc	V  Screws 1/4" x60 12pcs
--	---	---

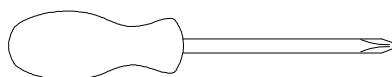

Assembly Tools Required (Not Included)

STEP 1:

-Using HW #A,#B to connect 11,12 Legs with 4(x2),5,13 and 14 Wood Bars

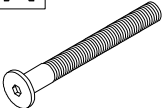

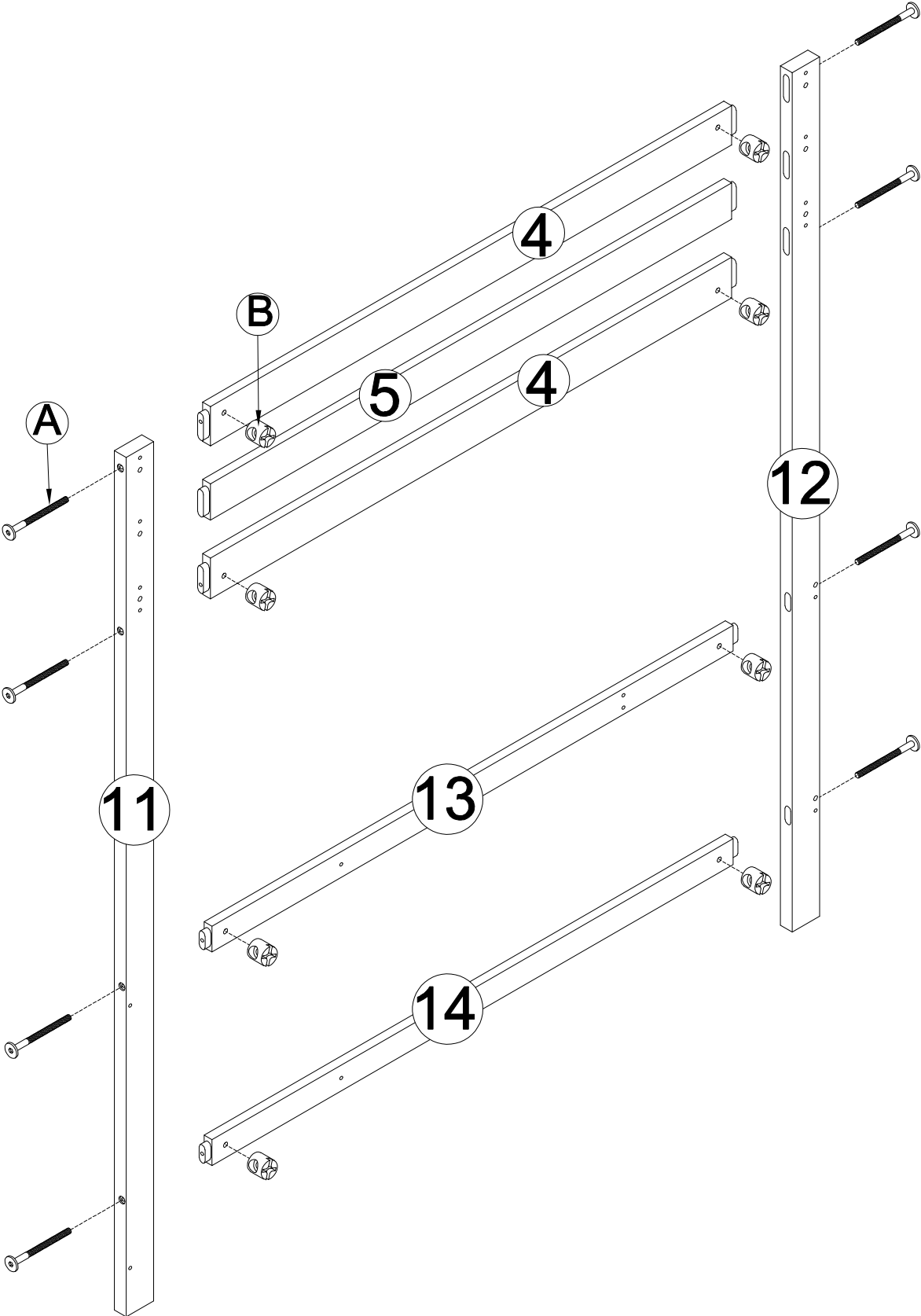
B		A	
	8pcs		8pcs



STEP 2:

-Using HW #C to connect 3 Top Rail with Frame
(Completed in step 1)

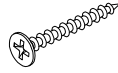
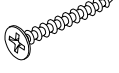
-Using HW #D to connect Steel Bracket E with Frame
(Completed in step 1)

D 	C 
4pcs	5pcs
E 	
1pc	

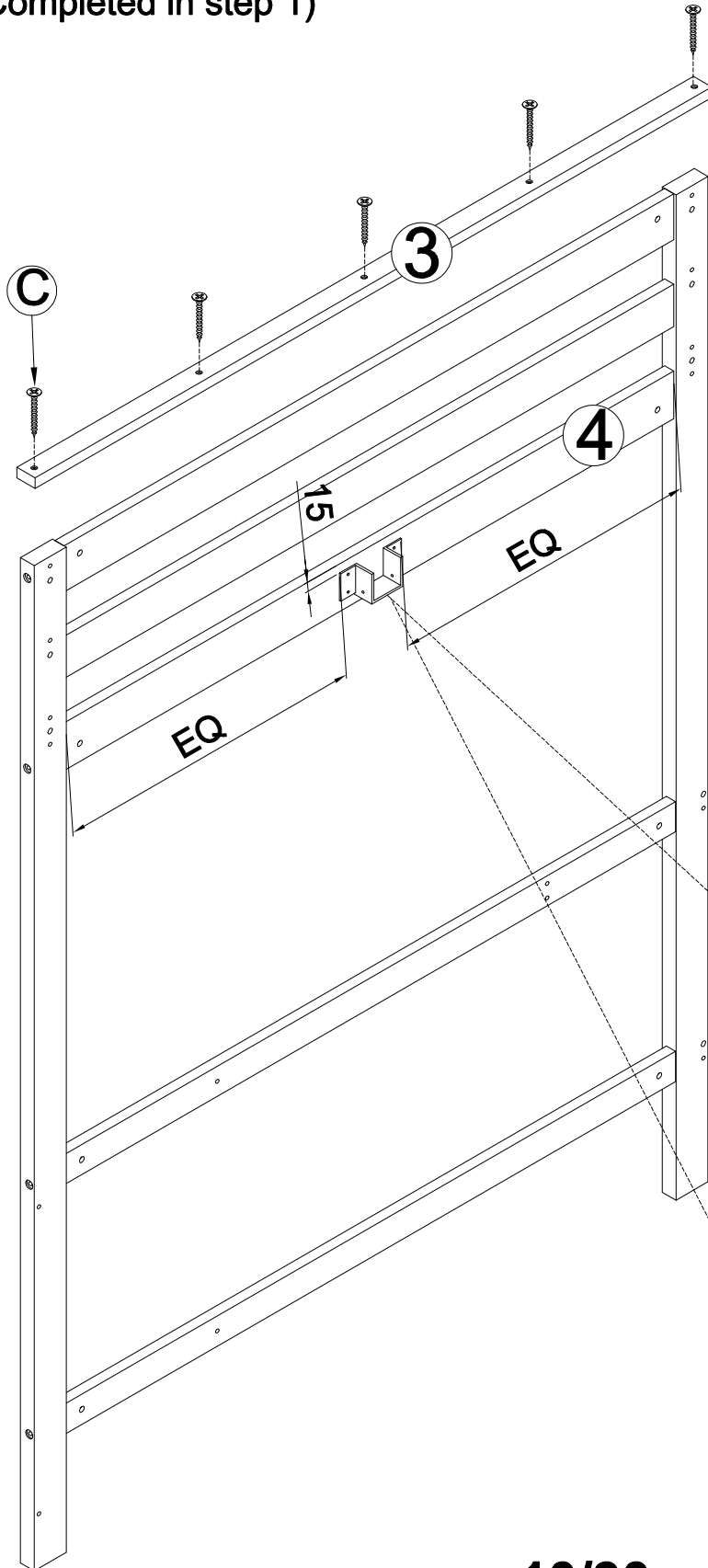

EQ:equal

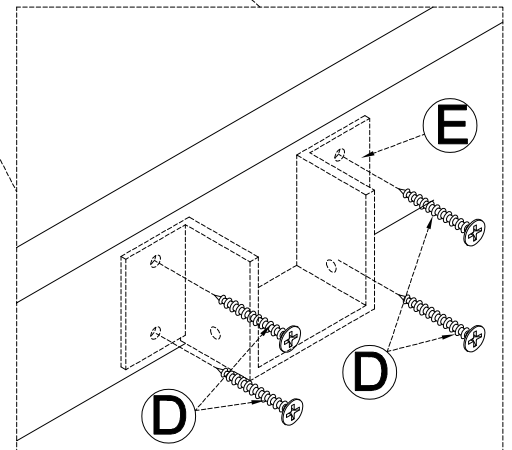

STEP 3:

-Using HW #A,#B to connect 9,10 Legs with 4(x2),5 Wood Bars

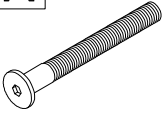

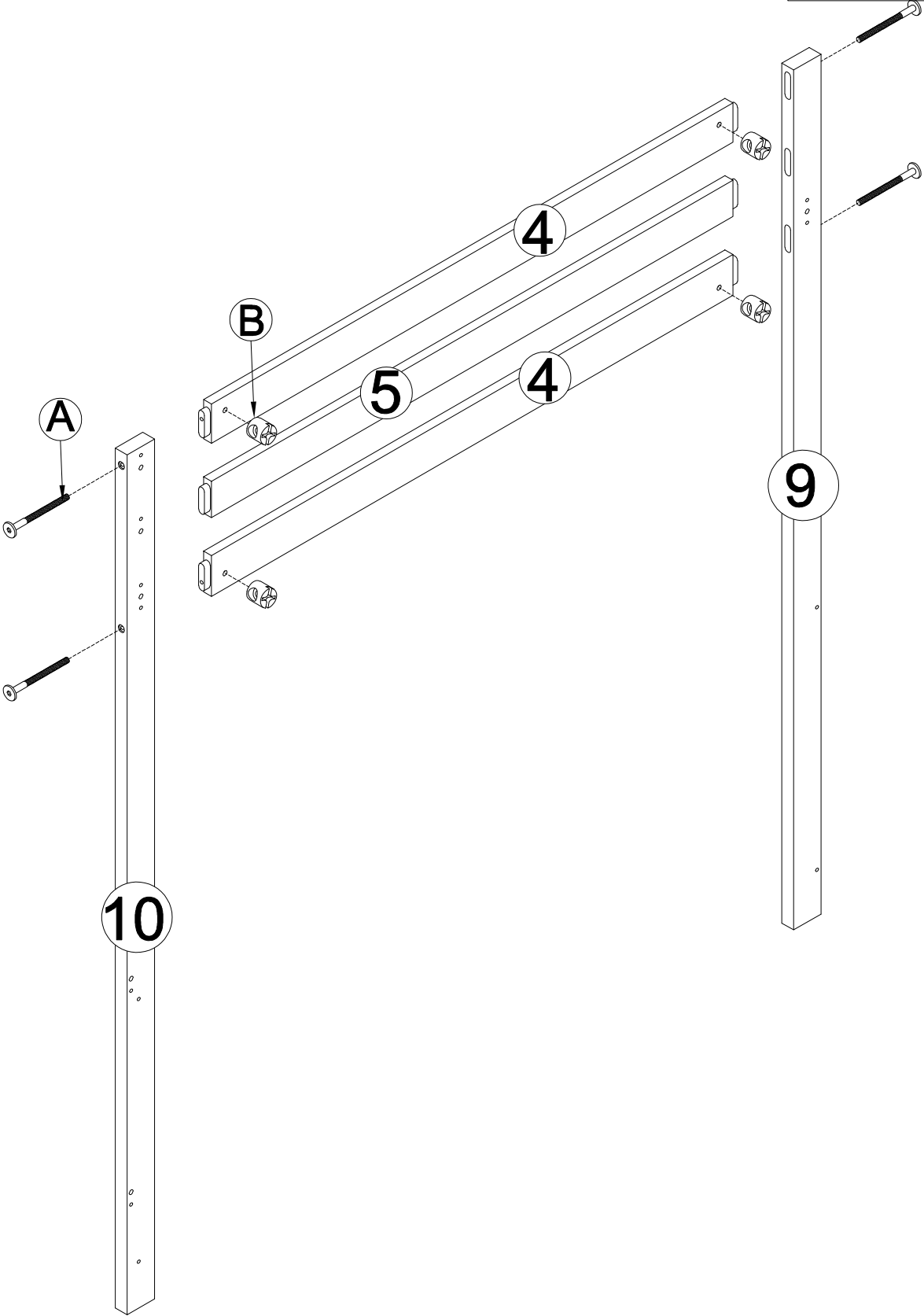
B 	A 
4pcs	4pcs



STEP 4:

-Using HW #C to connect 3 Top Rail with Frame
(Completed in step 3)

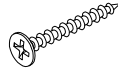
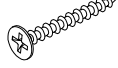
-Using HW #D to connect Steel Bracket E with Frame
(Completed in step 3)

D 	C 
4pcs	5pcs
E 	
1pc	

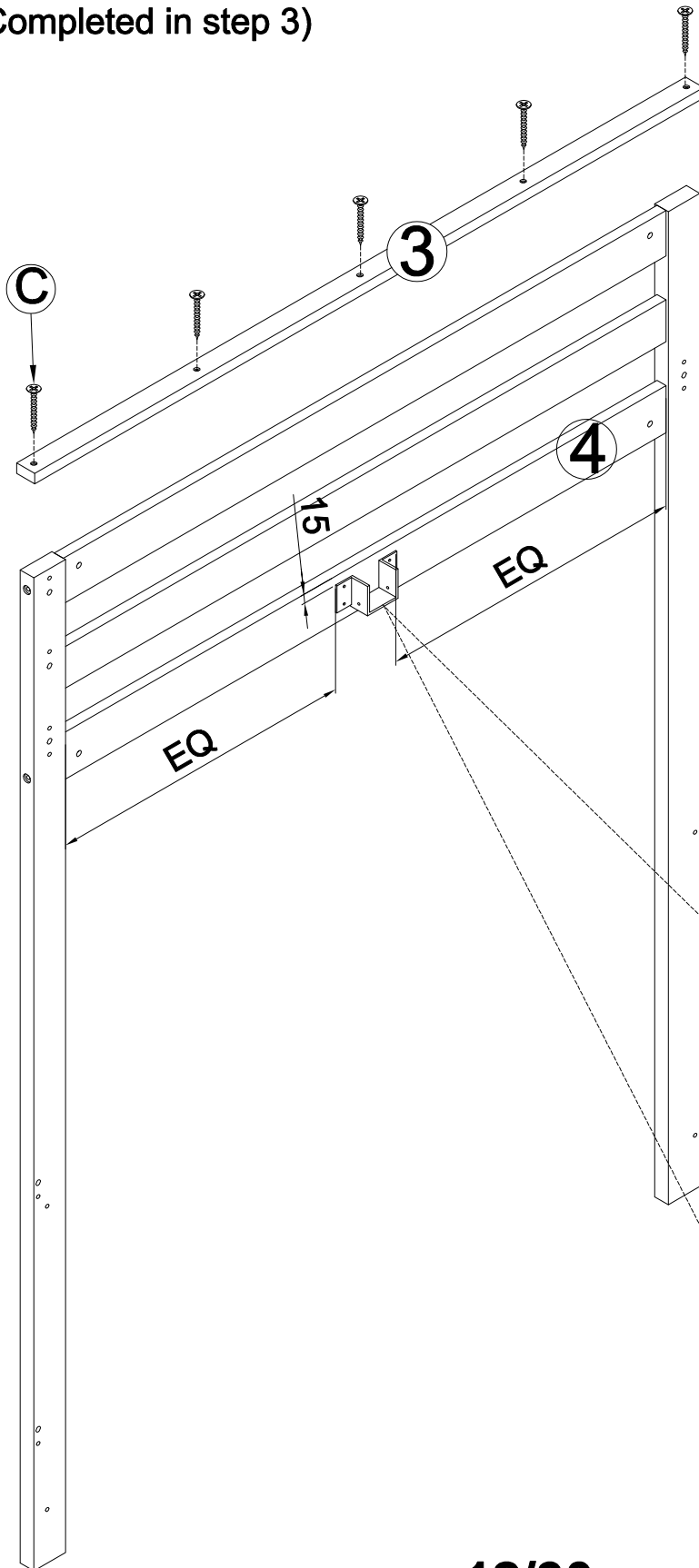

EQ:equal

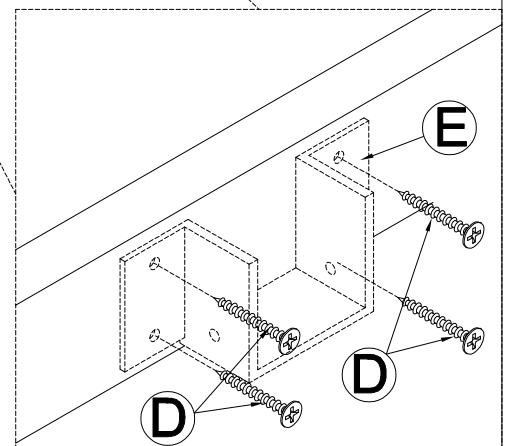

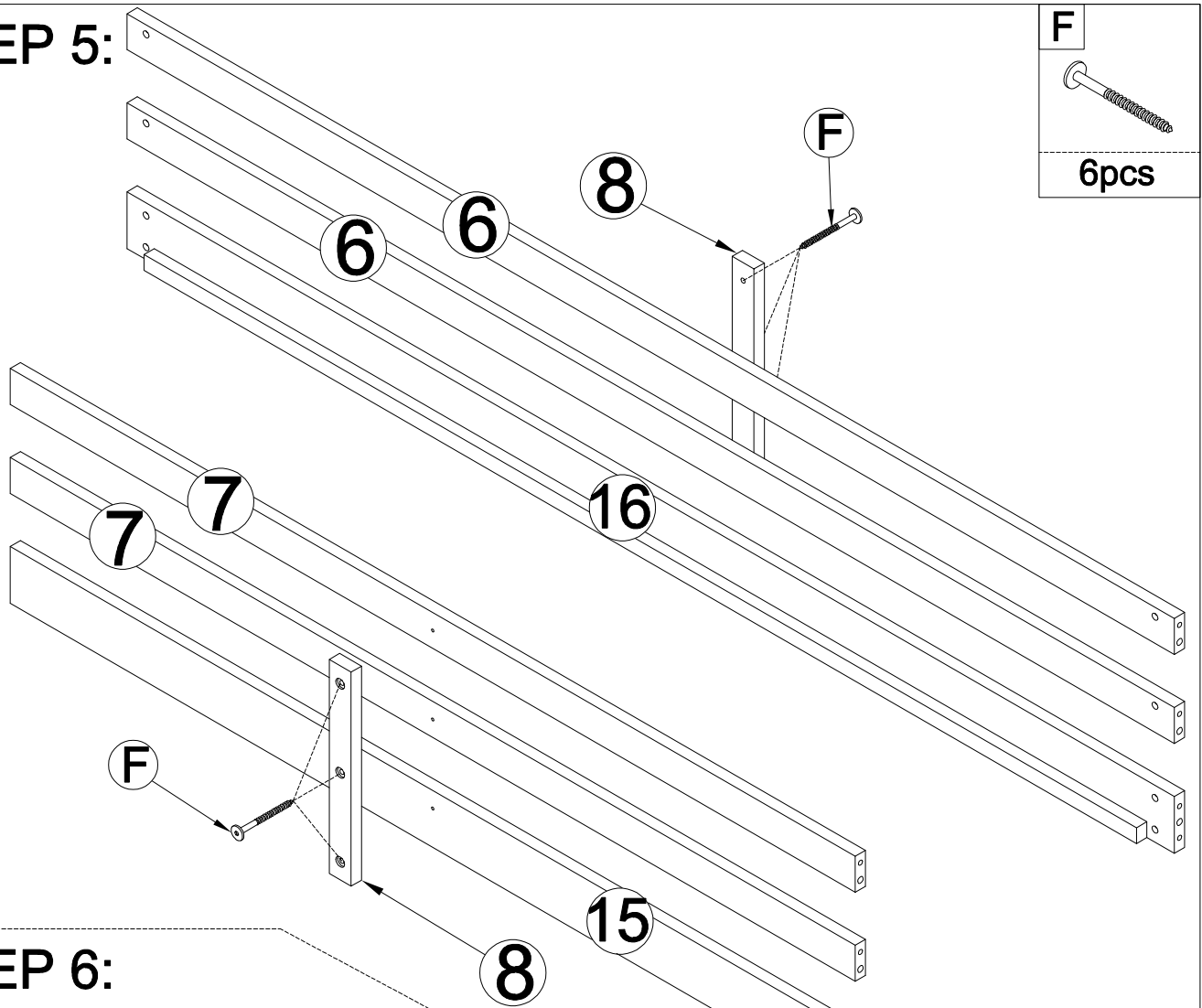

STEP 5:

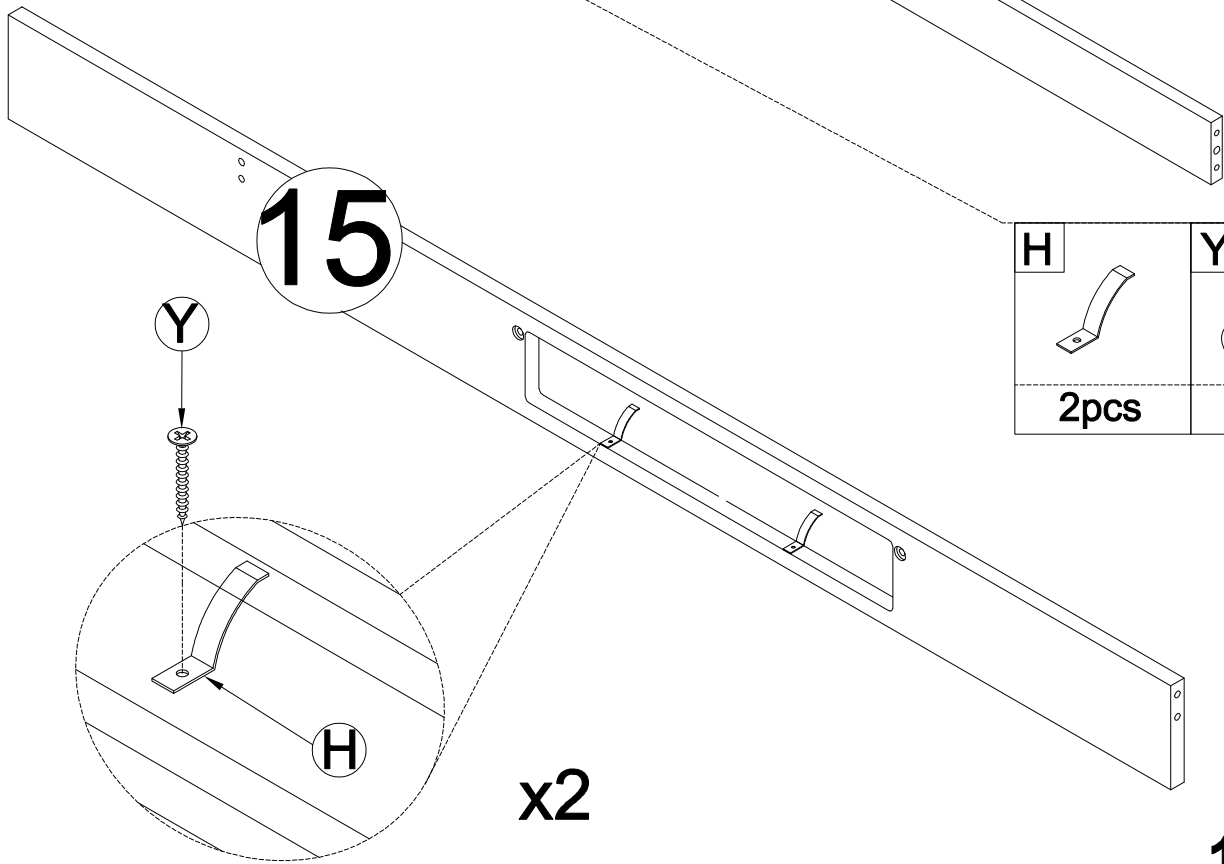

F

6pcs

STEP 6:

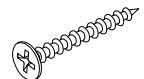

H	Y
	
2pcs	2pcs

STEP 7:



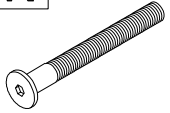
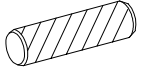

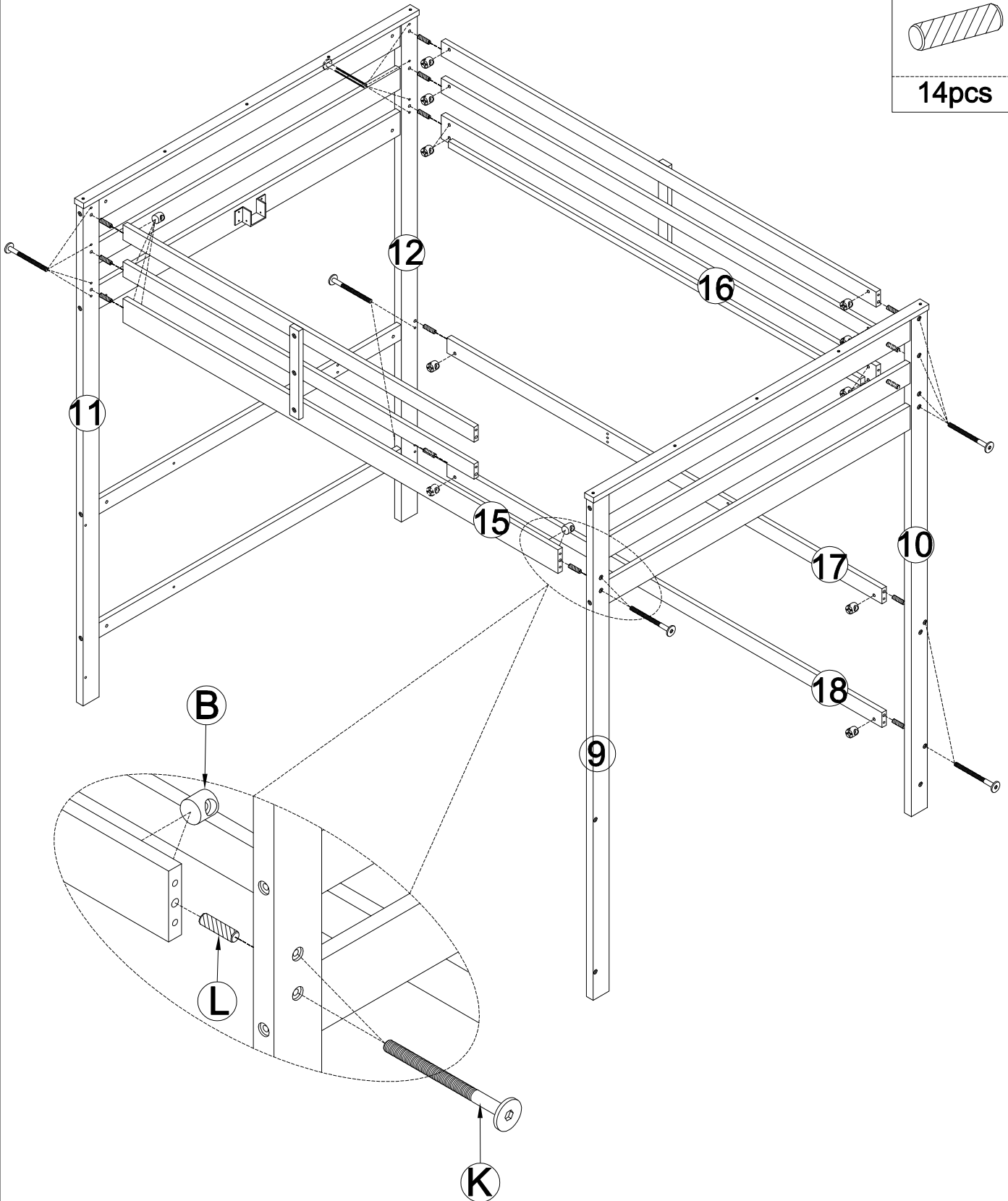
-Using HW #B,#K and Dowel L to connect Frames (completed in step 2,4) with Frame(Completed in step 5) and 17,18 Rails

B 	K 
18pcs	18pcs
	L 
	14pcs



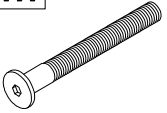

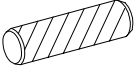
STEP 8:

-Using HW #B,#M,#N,#P and Dowel L to connect Frames (completed in step 7) with 22 Rail

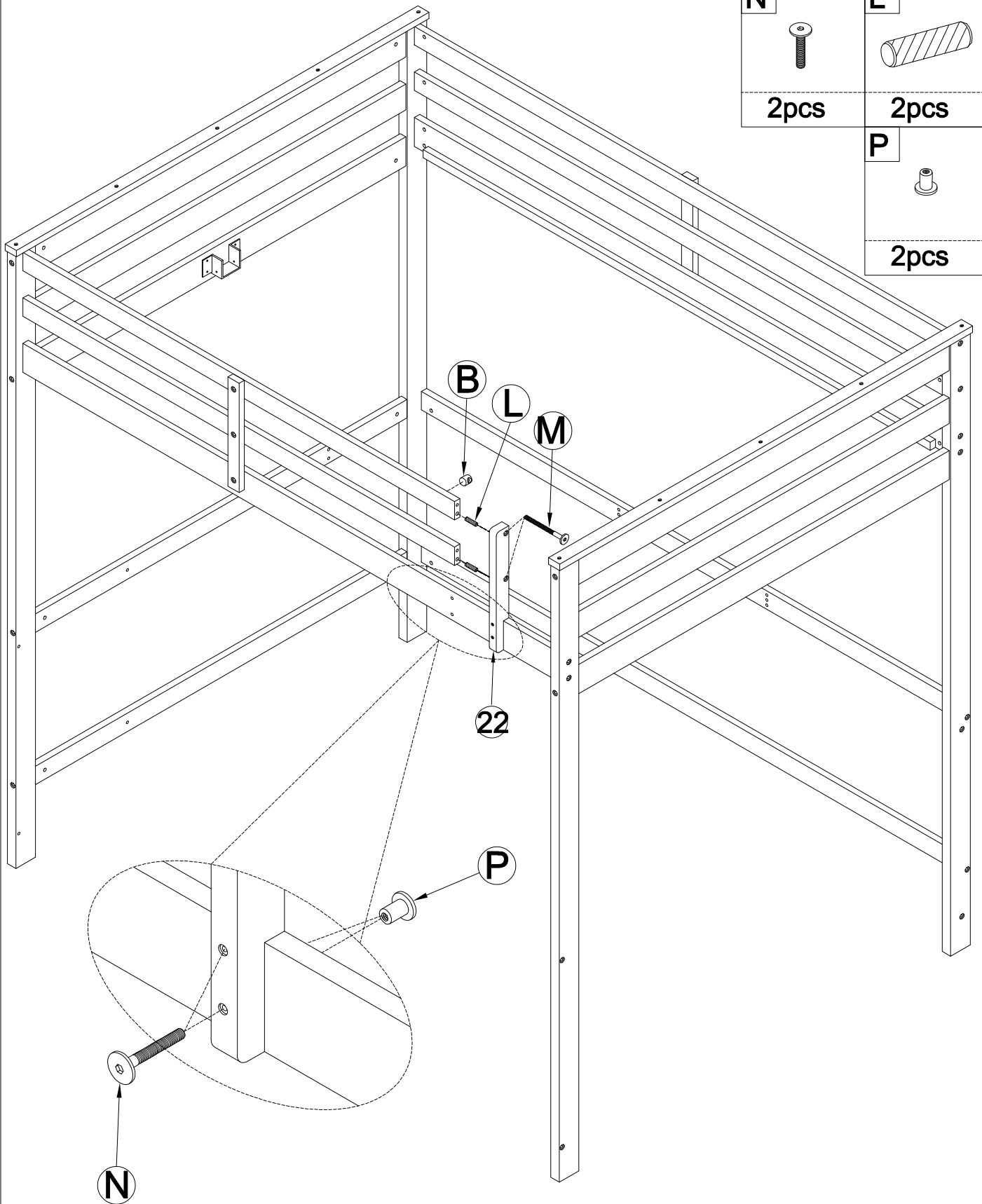

B 	M 
2pcs	2pcs
N 	L 
2pcs	2pcs
	P 
	2pcs

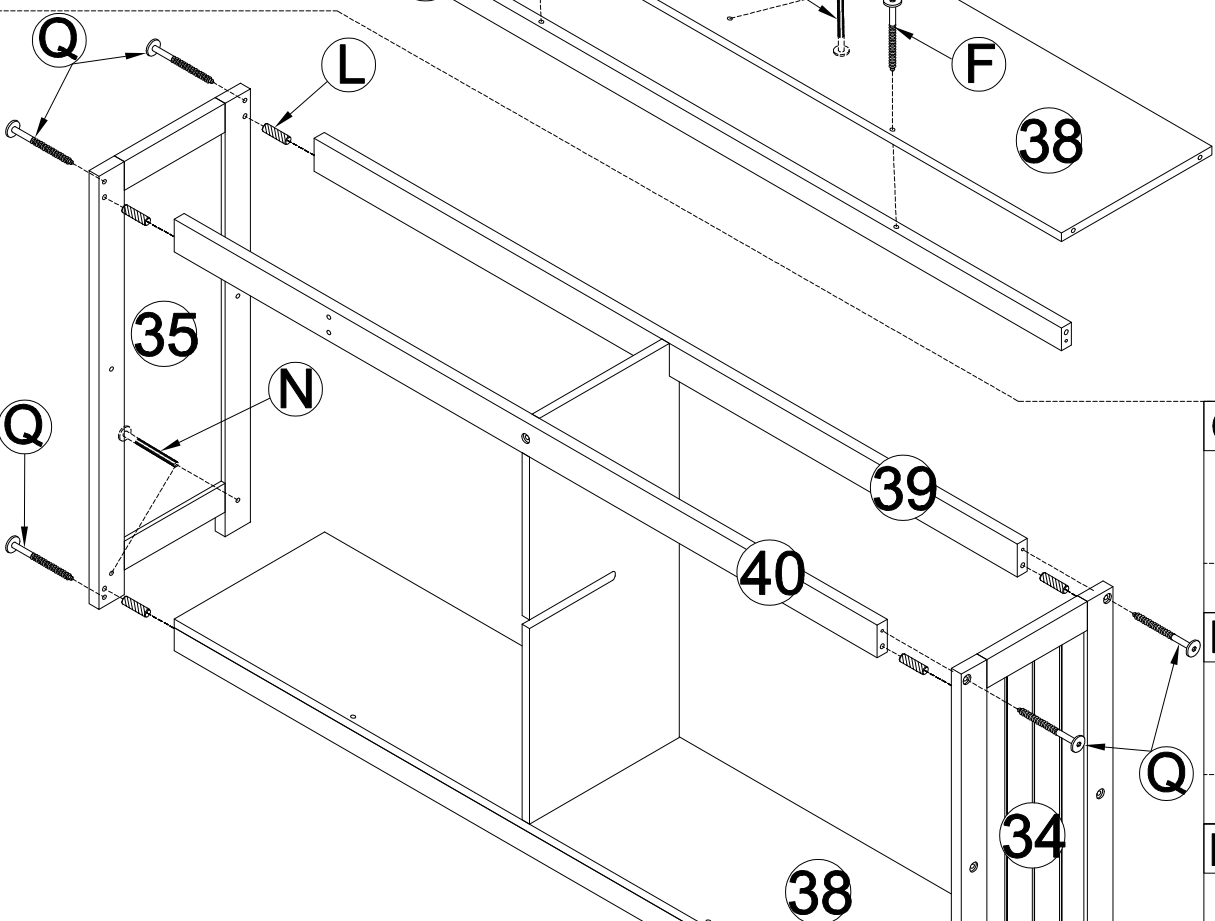
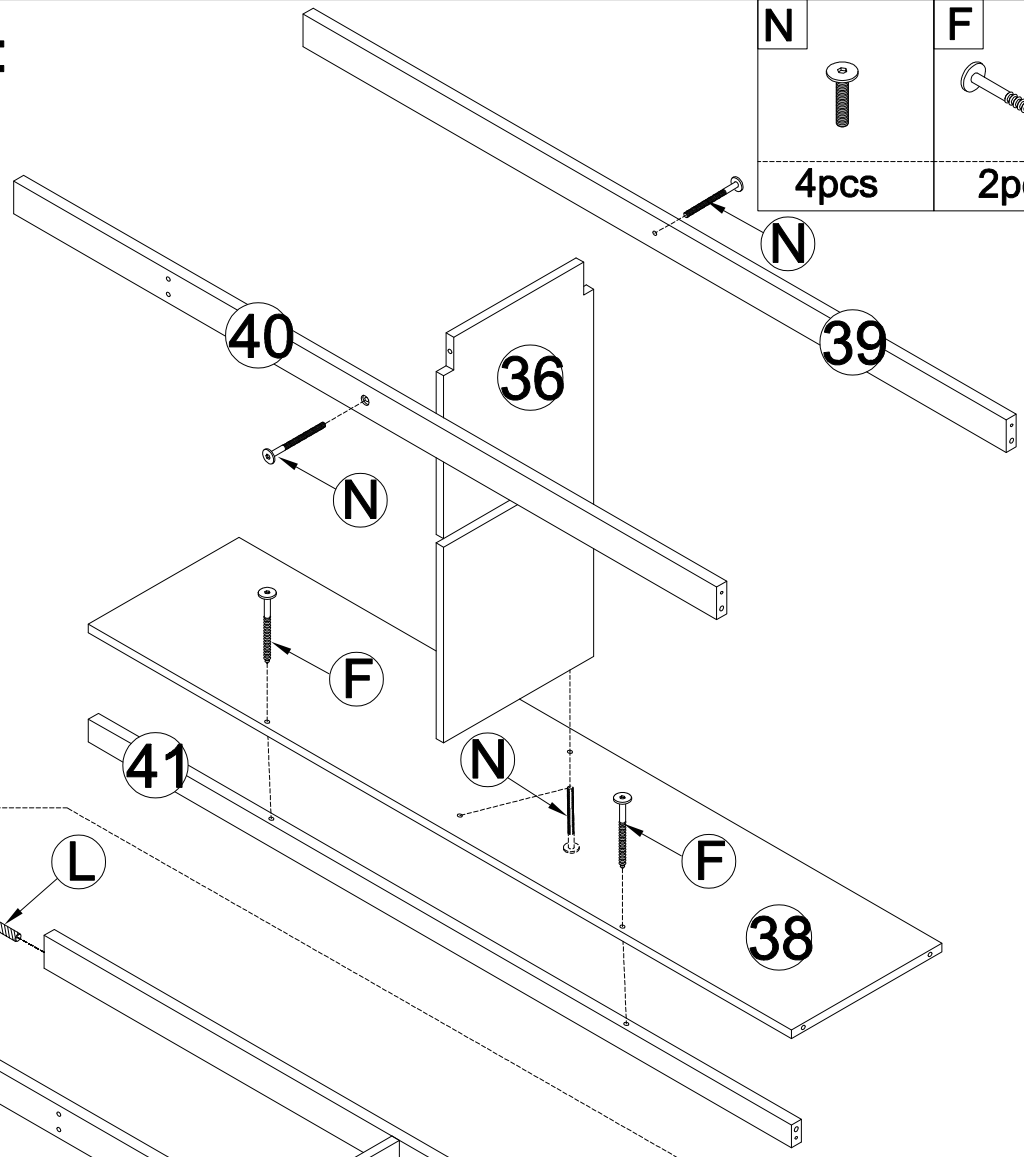

STEP 9-1:

N	F
	
4pcs	2pcs

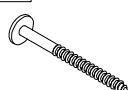
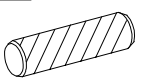

Q	
6pcs	
L	
6pcs	
N	
4pcs	

STEP 9-2:

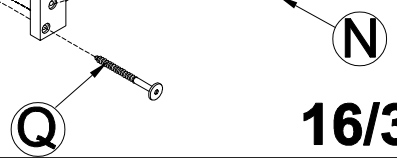

STEP 9-3:

N



4pcs

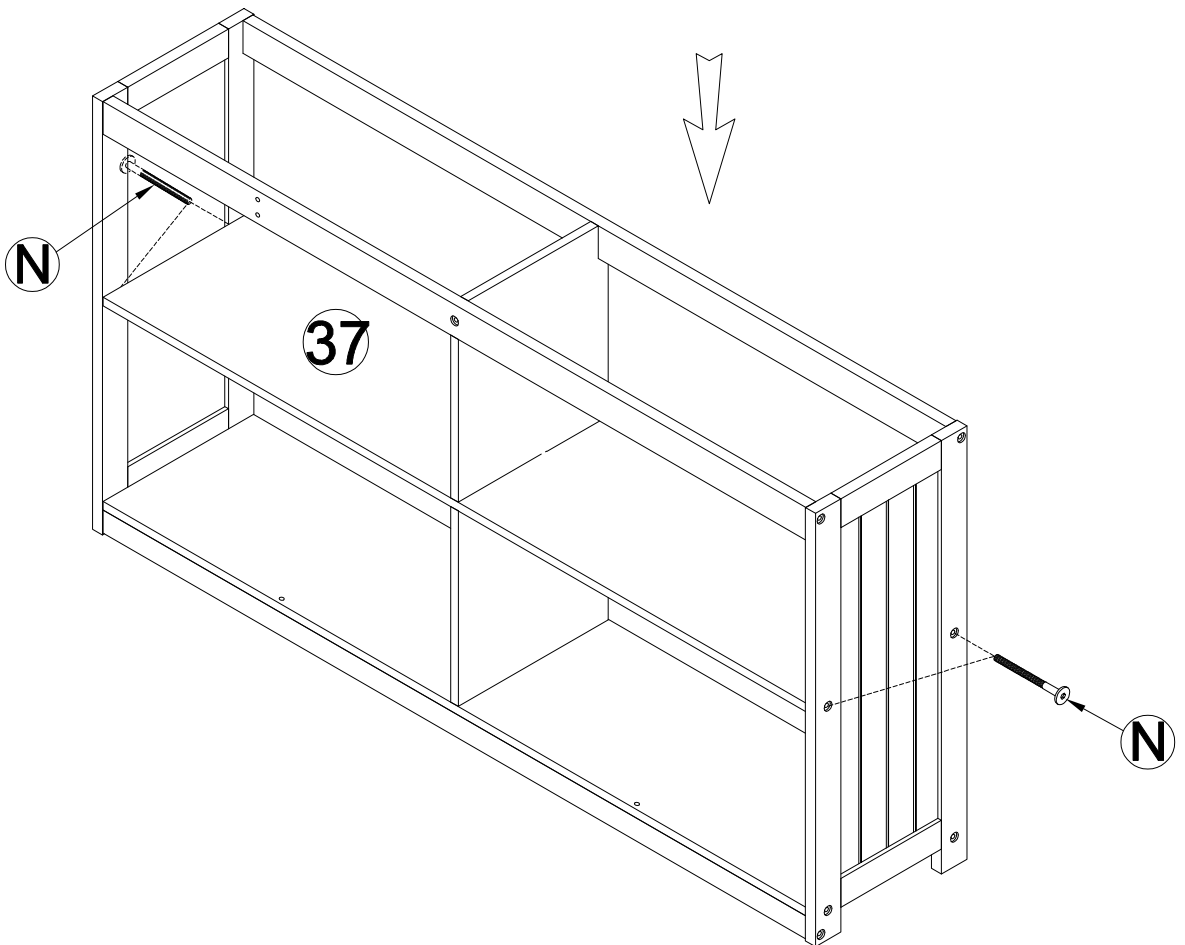
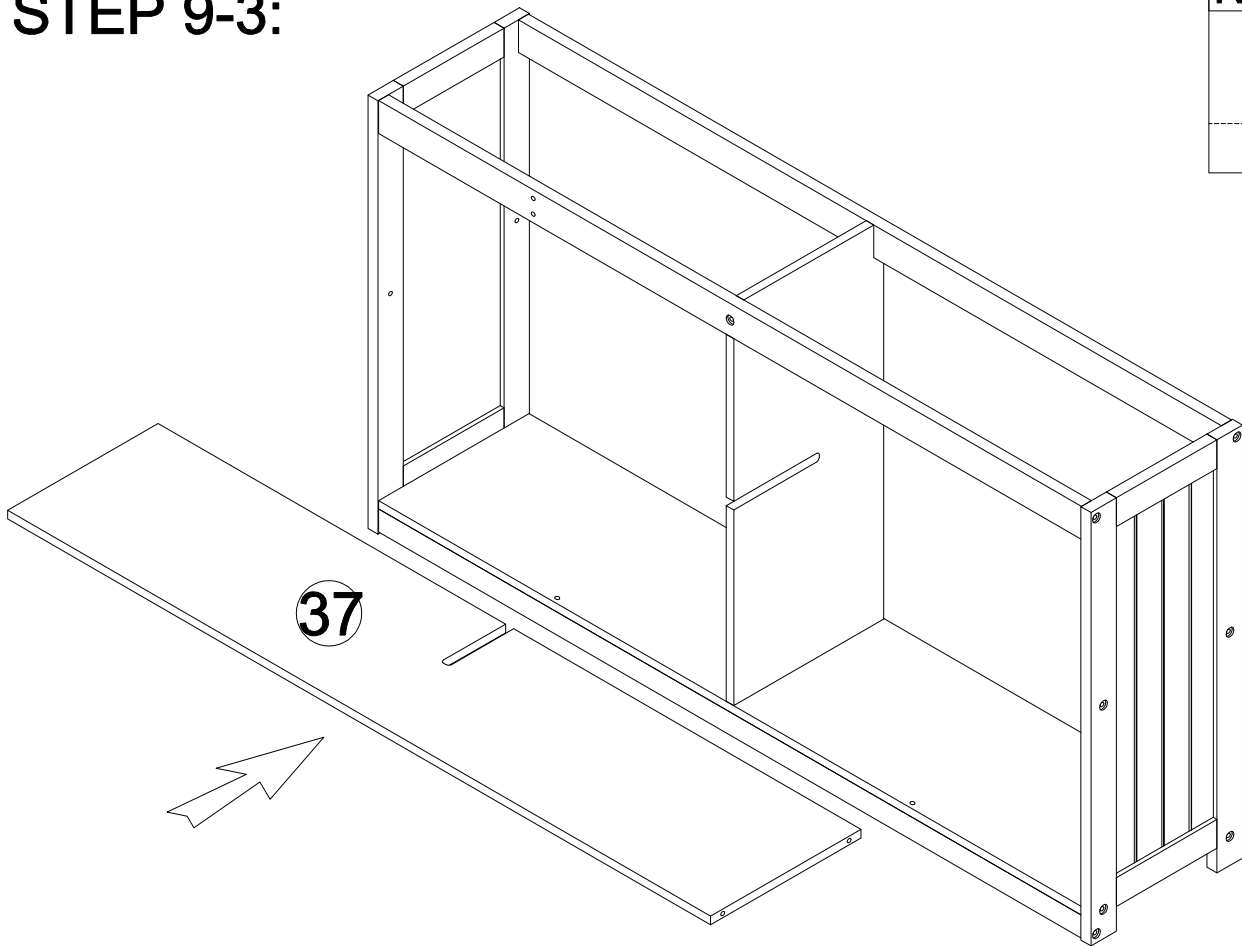

STEP 10-1:

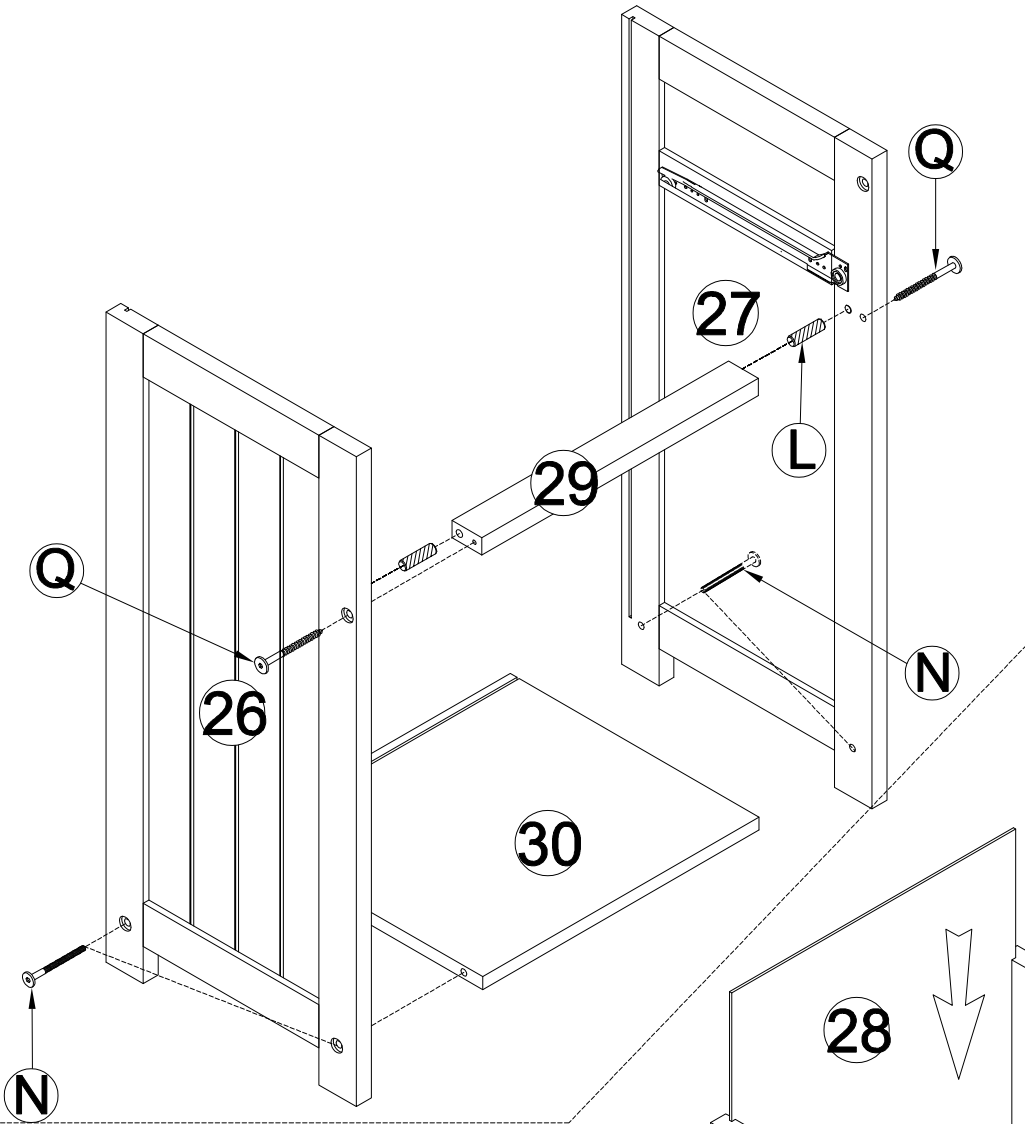

- | | |
|---|------|
| N | |
| | 4pcs |
| Q | |
| | 2pcs |
| L | |
| | 2pcs |

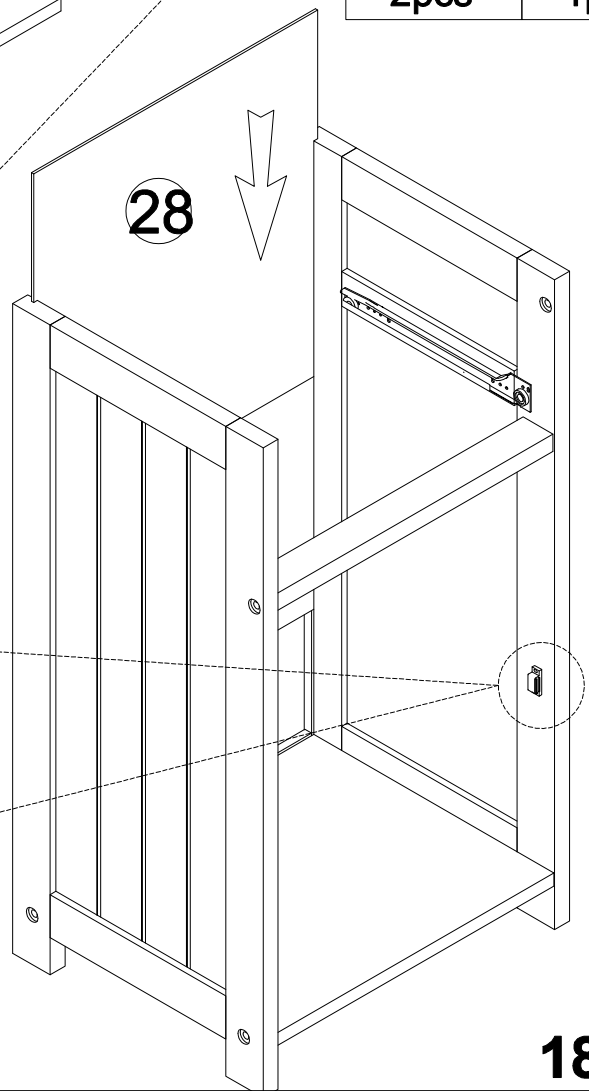
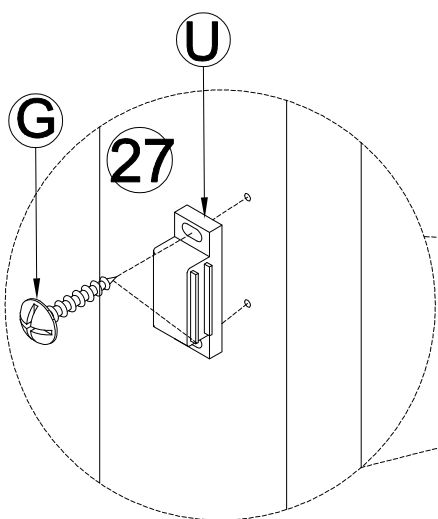

- | | | | |
|---|------|---|-----|
| G | | U | |
| | 2pcs | | 1pc |

STEP 10-2



STEP 11:

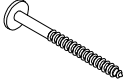

-Using HW #Q,#R to connect Frames (completed in step 10-2 ,step 9-3) with Frame(Completed in step 8) and 17,18 Rails

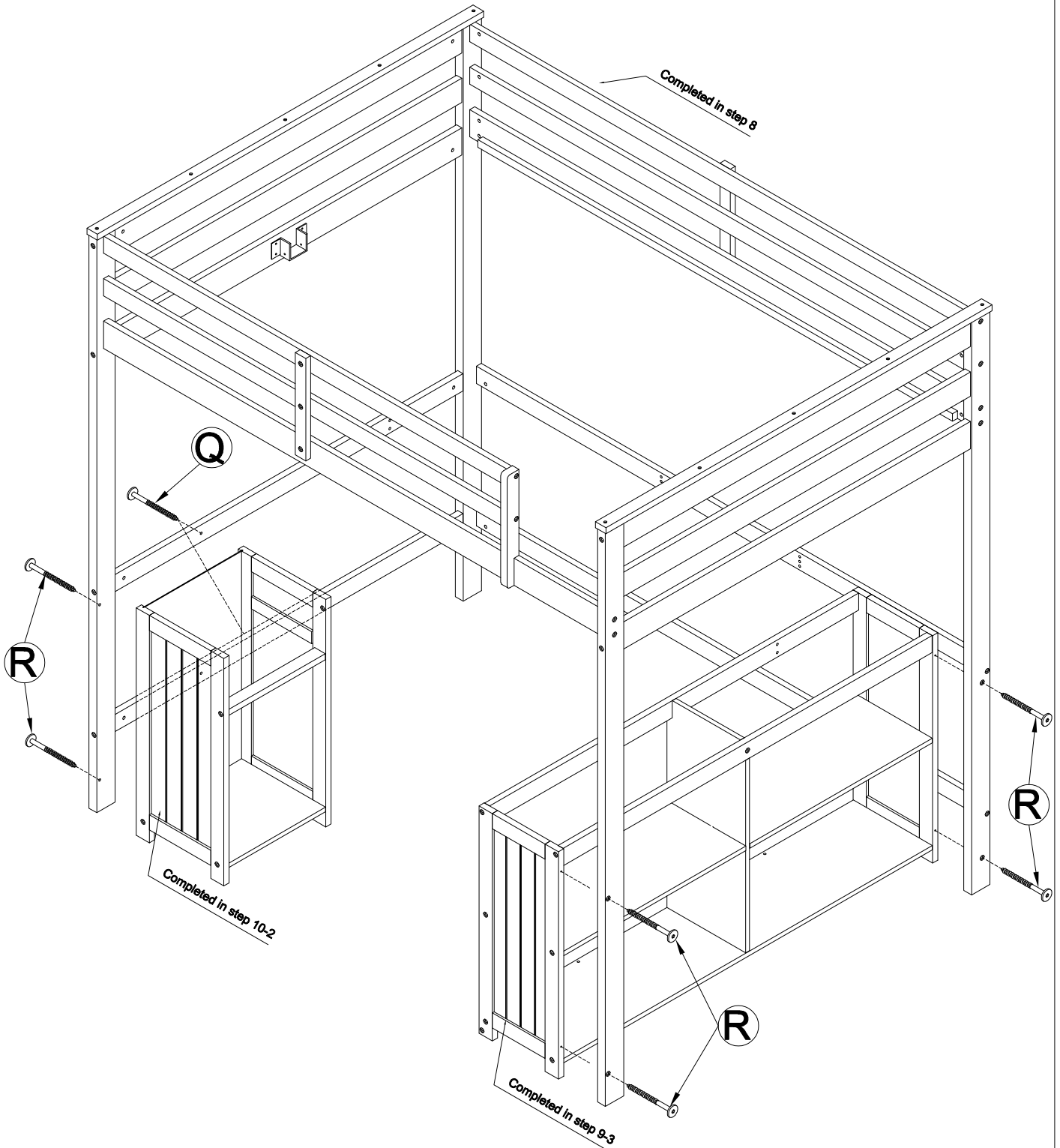
R	
6pcs	
Q	
2pcs	

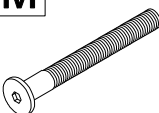
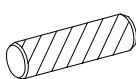
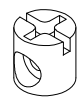

STEP 12:

Detail 2(x2)

M 	L 
4pcs	8pcs
B 	Q 
4pcs	4pcs

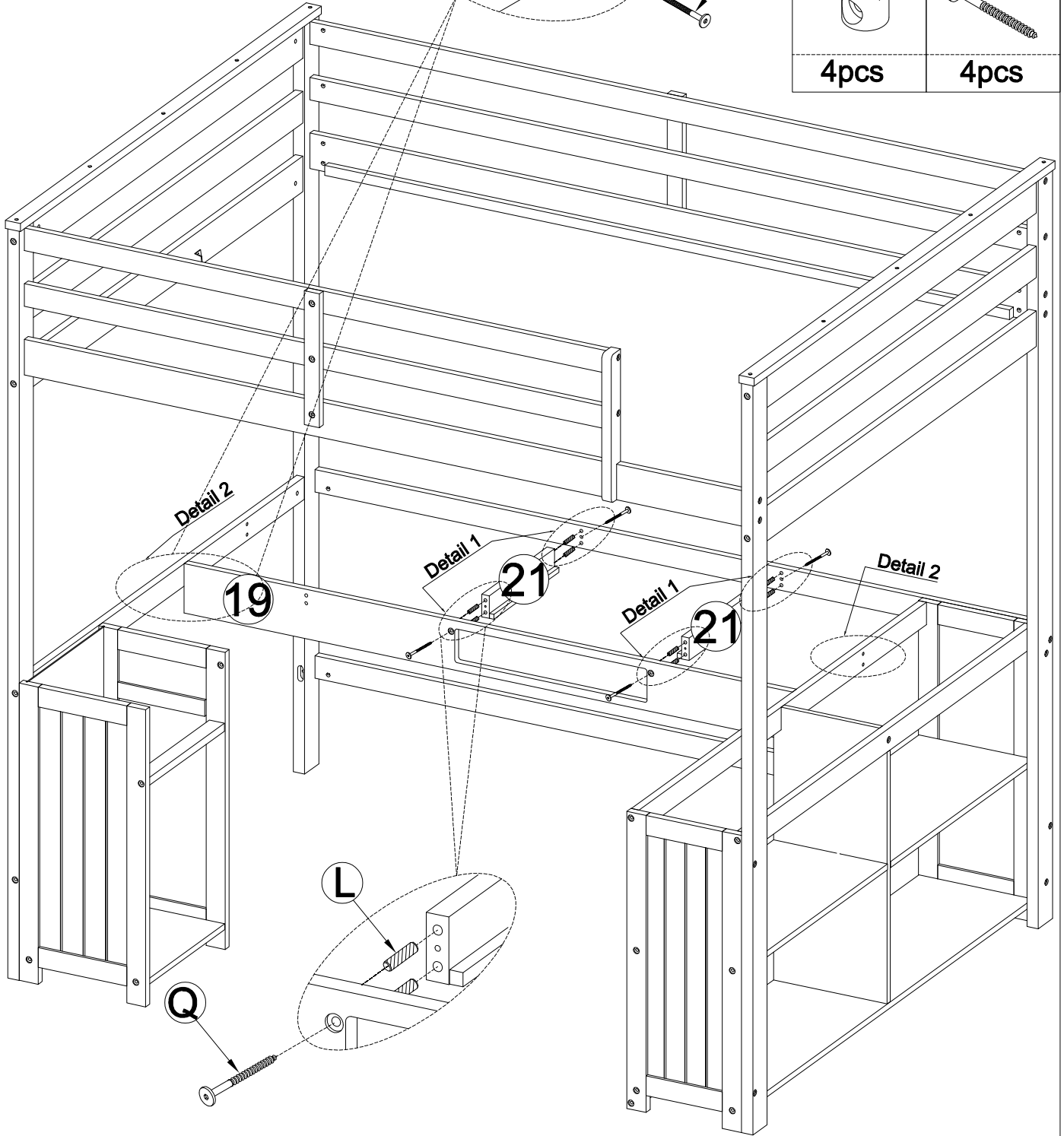

Detail 1(x4)

STEP 13:

Q

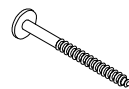

4pcs

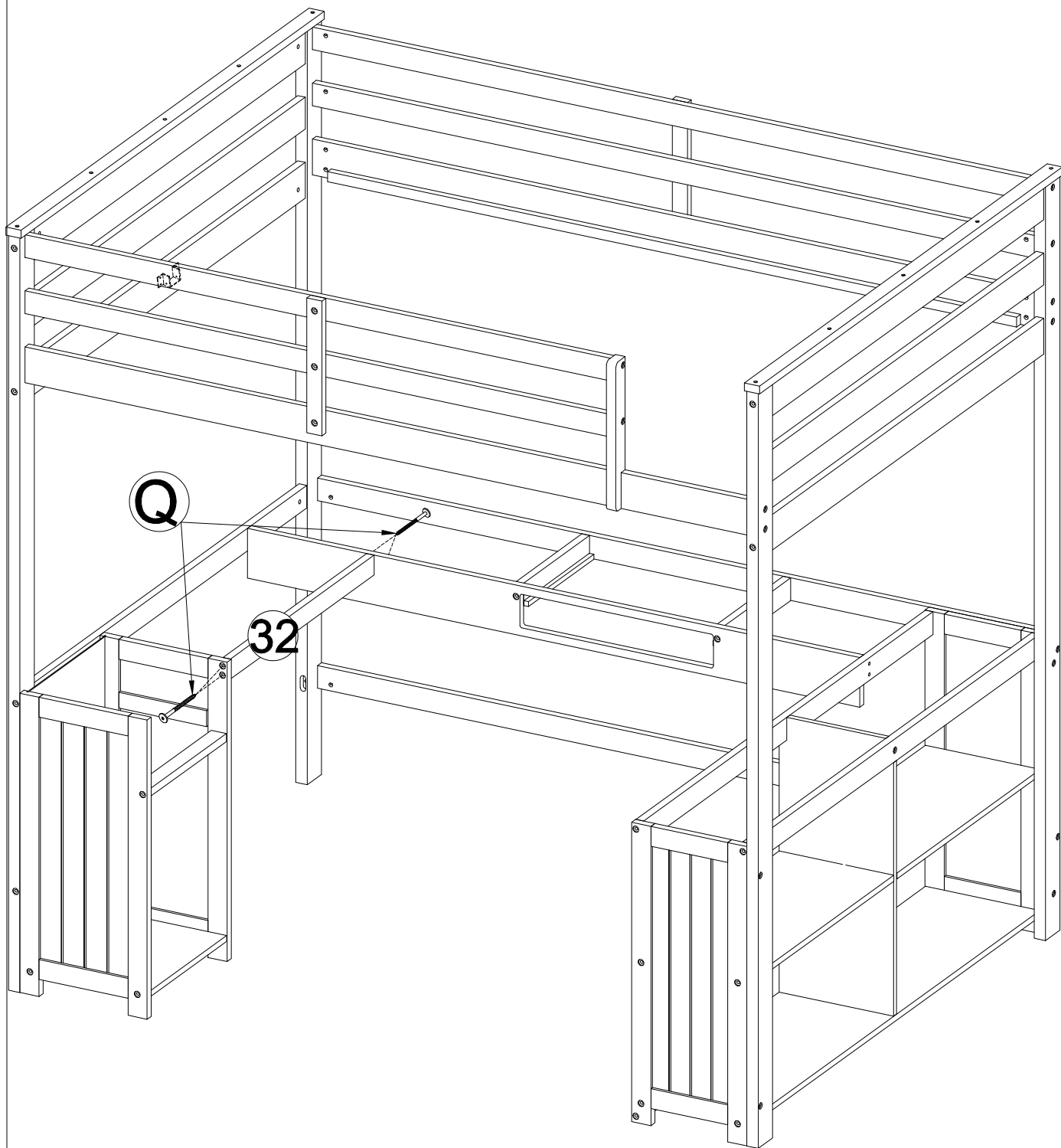

STEP 14:

D

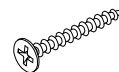

32pcs

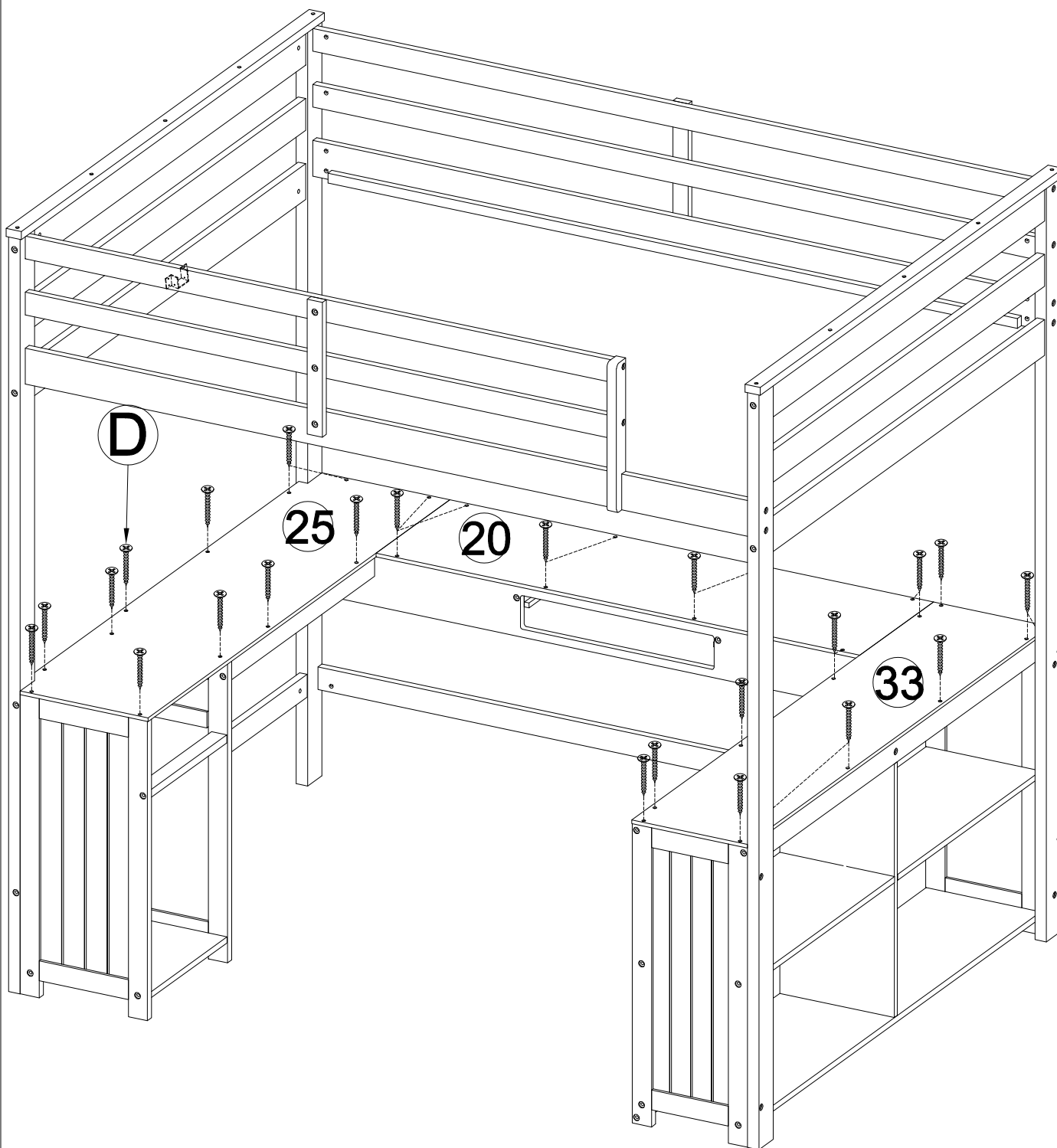

STEP 15-1:

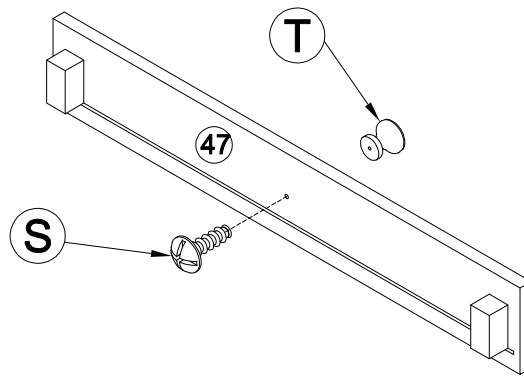

T	S
1pc	1pc

STEP 15-2:

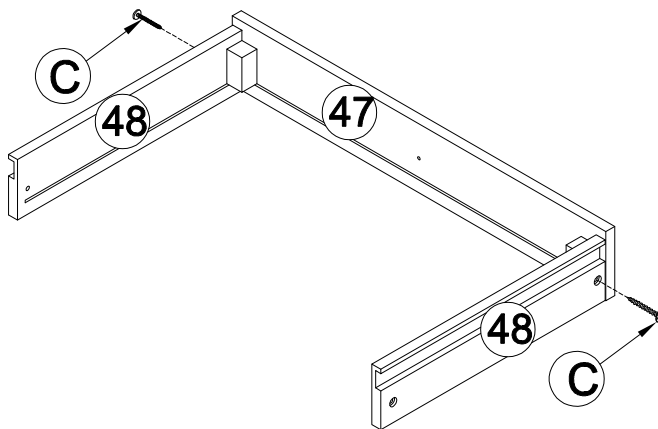

C	
2pcs	

STEP 15-3:

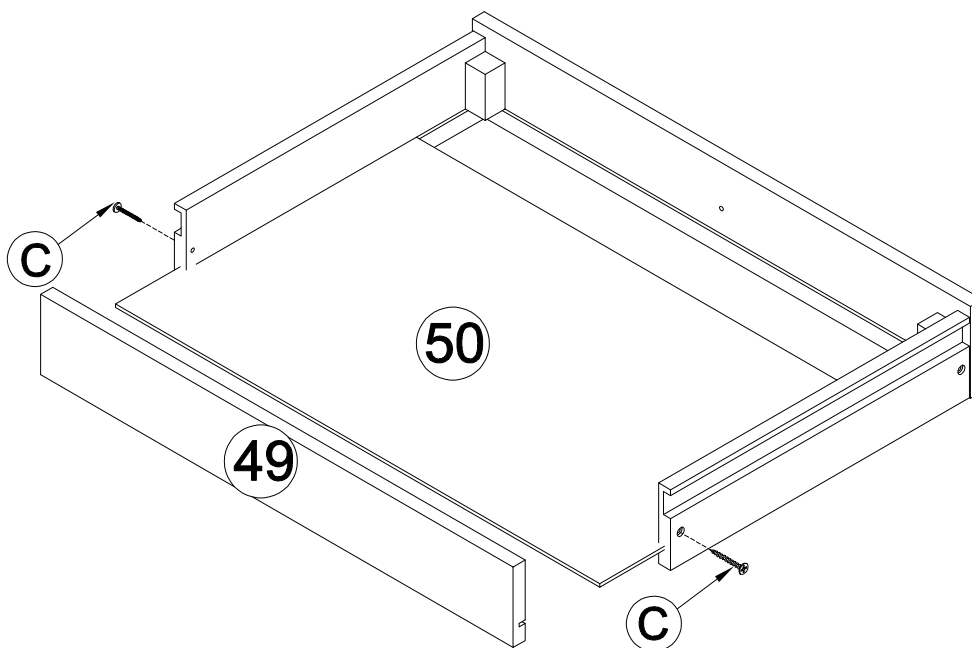

C	
2pcs	

STEP 16-1:

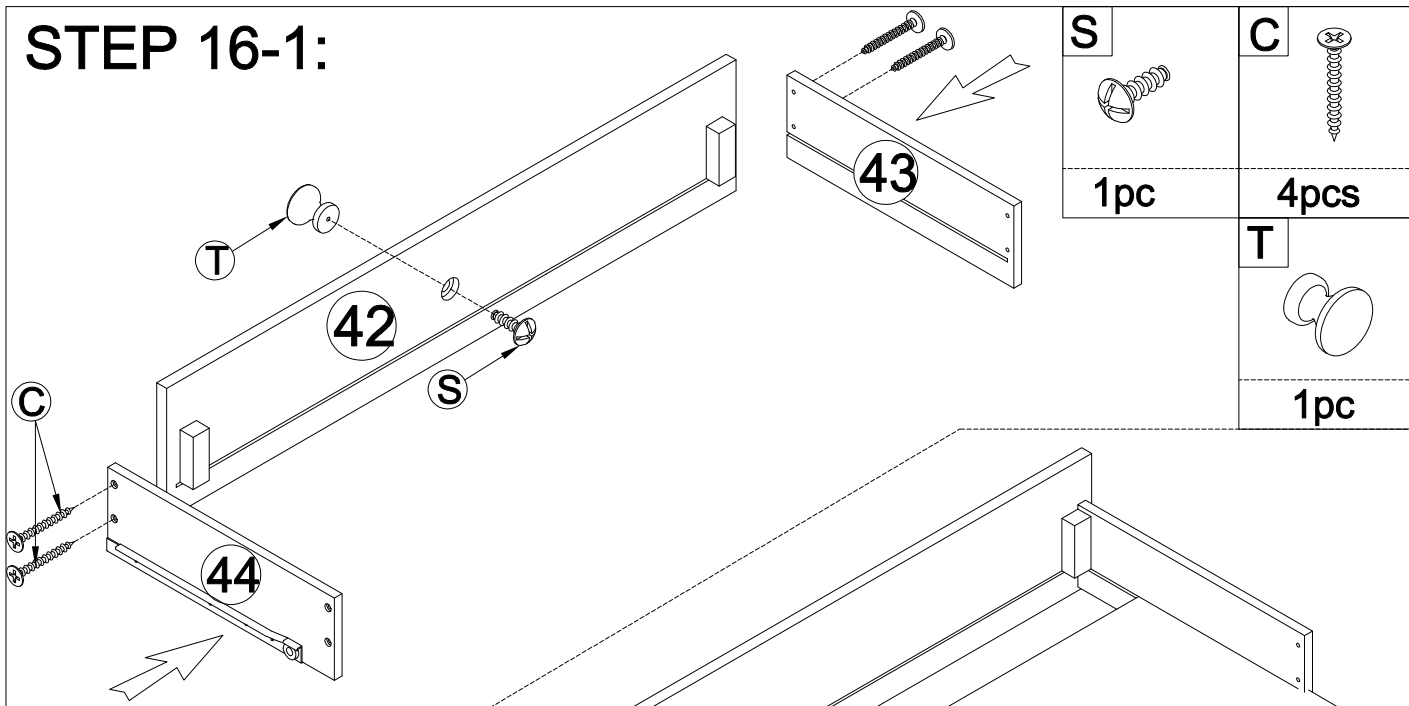

STEP 16-2:

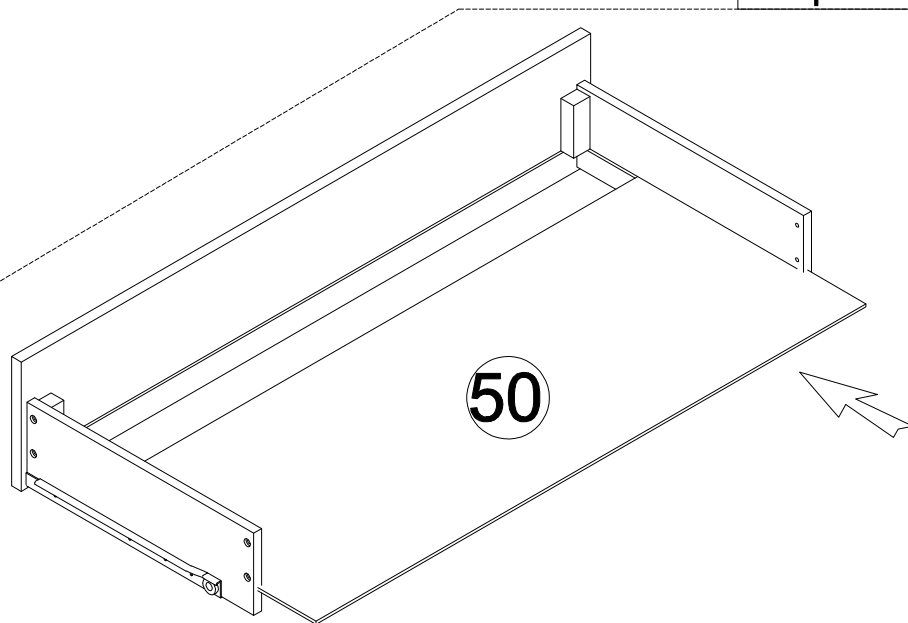

STEP 16-3:

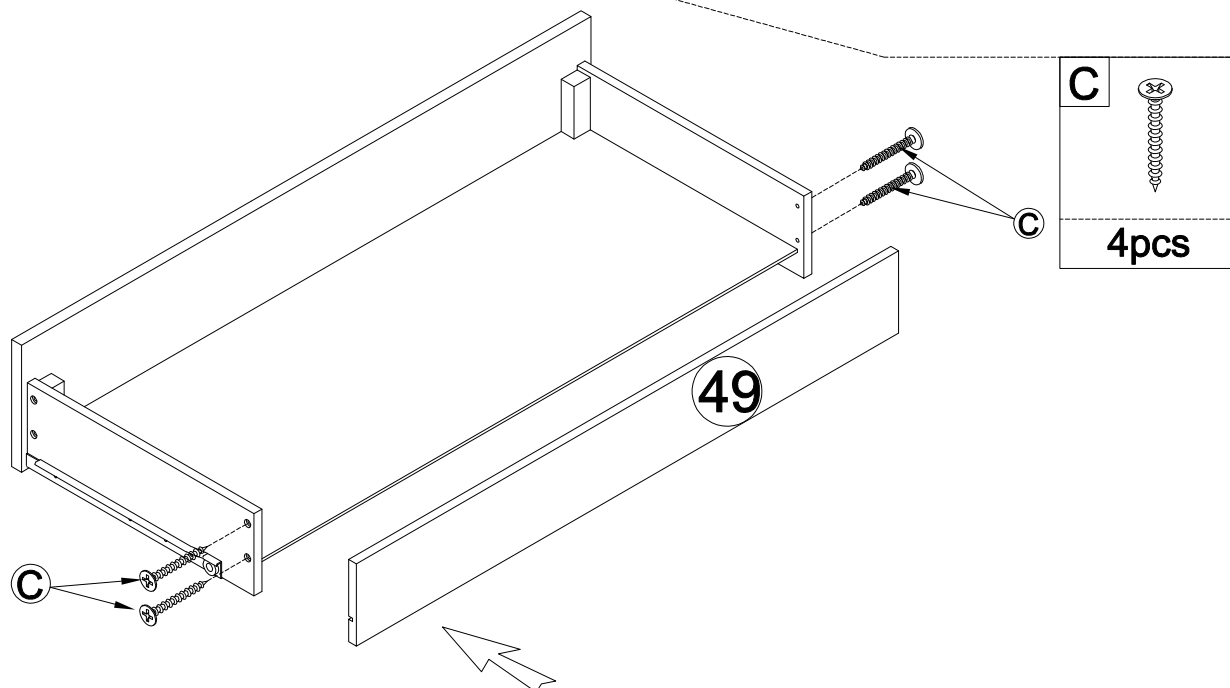

STEP 17:

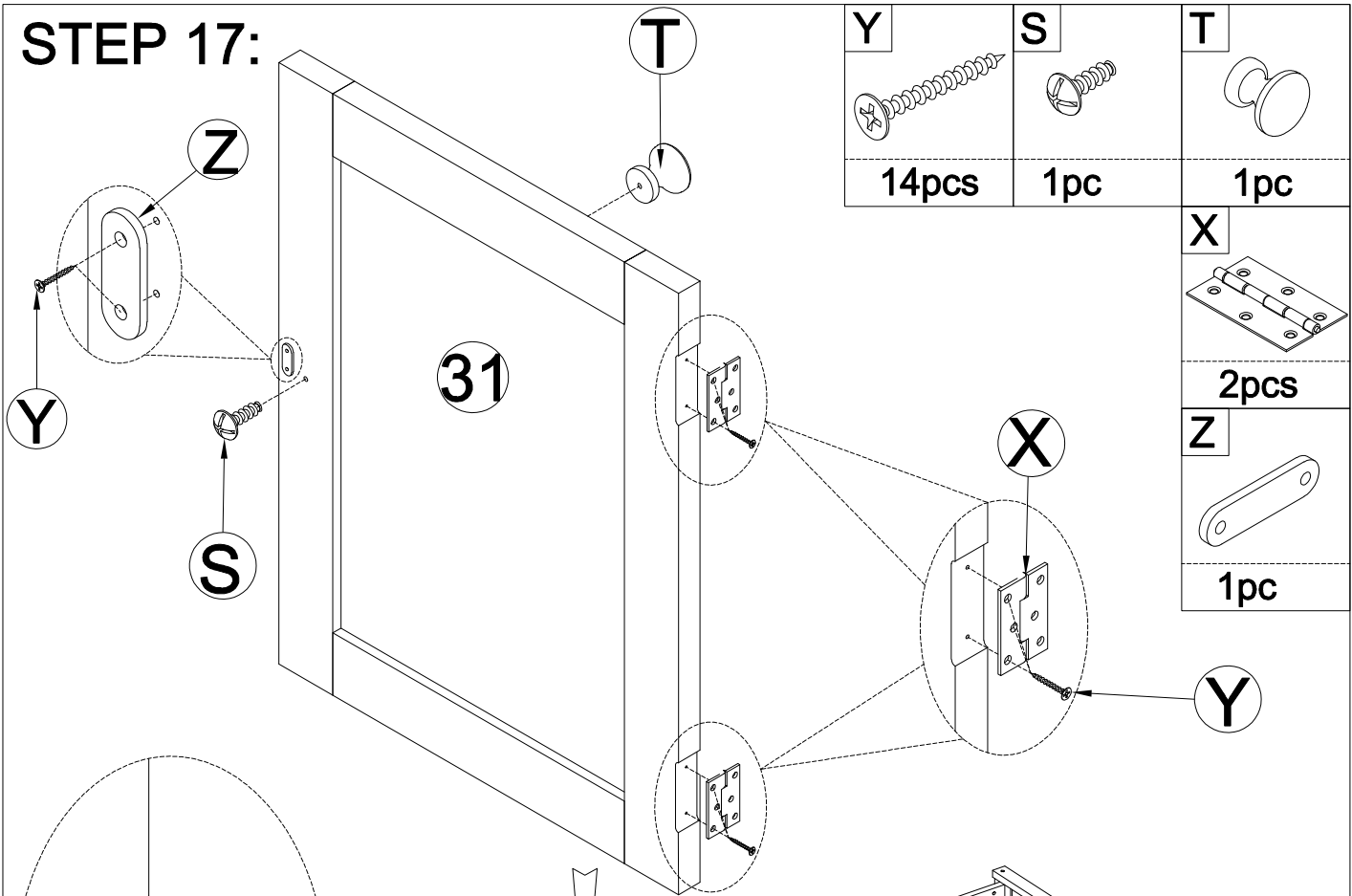

Y		S		T	
	14pcs		1pc		1pc

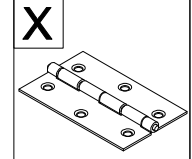

2pcs

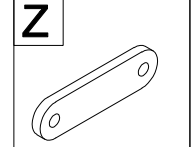

1pc

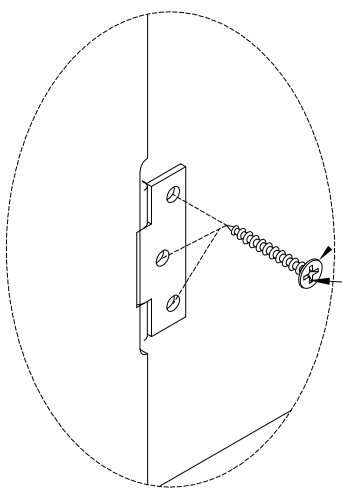

Detail 3(x2)

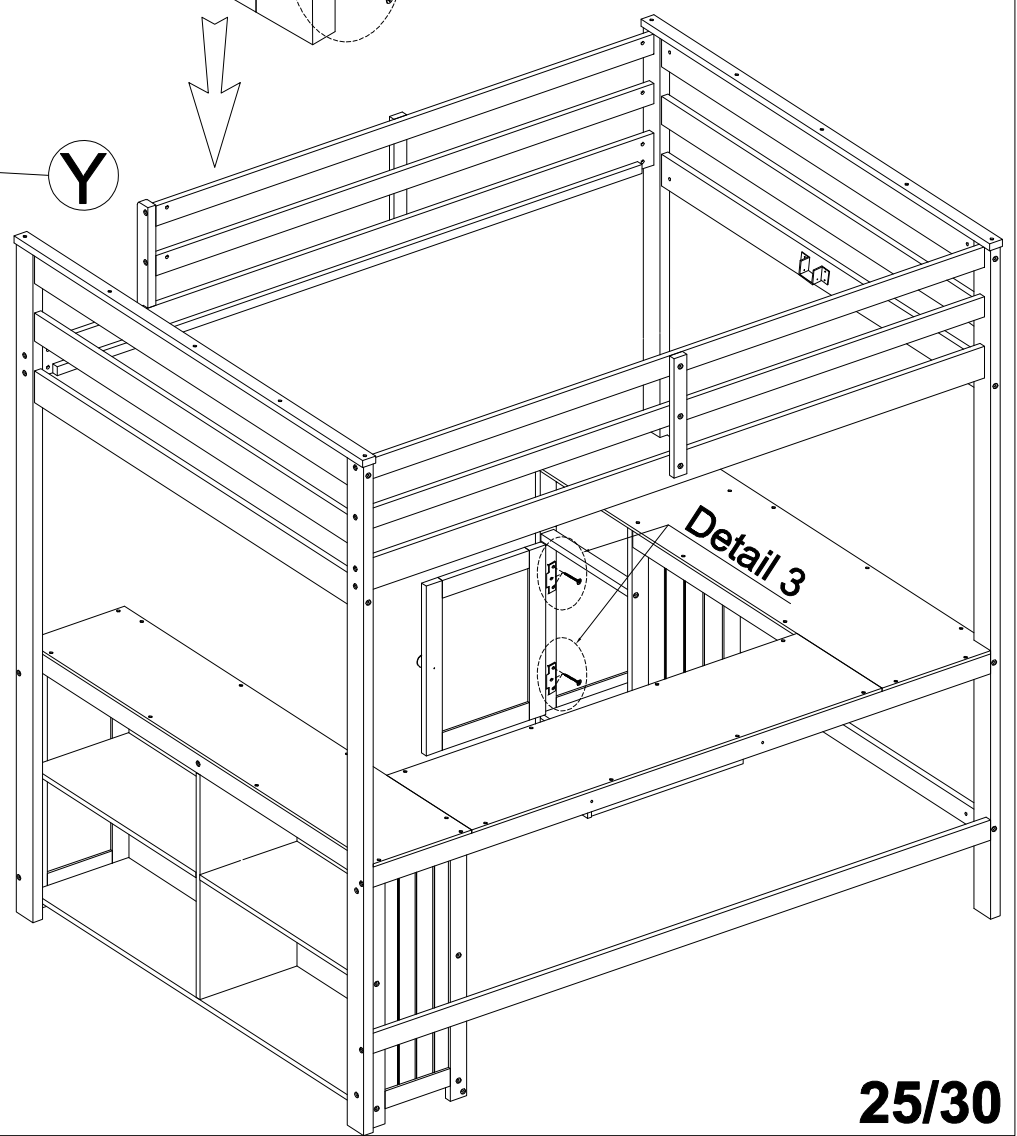



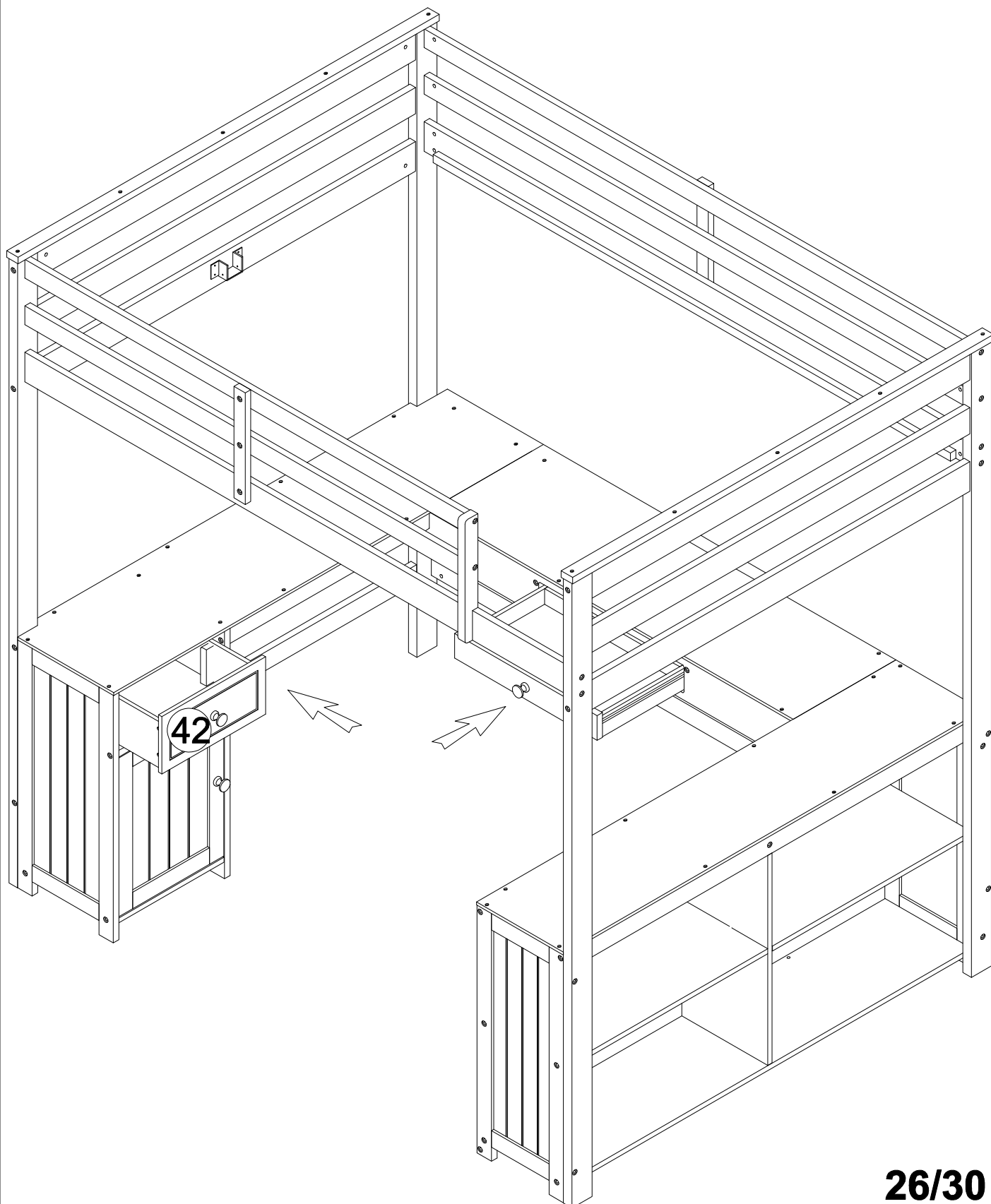

STEP 18: Push 2 drawer into it position

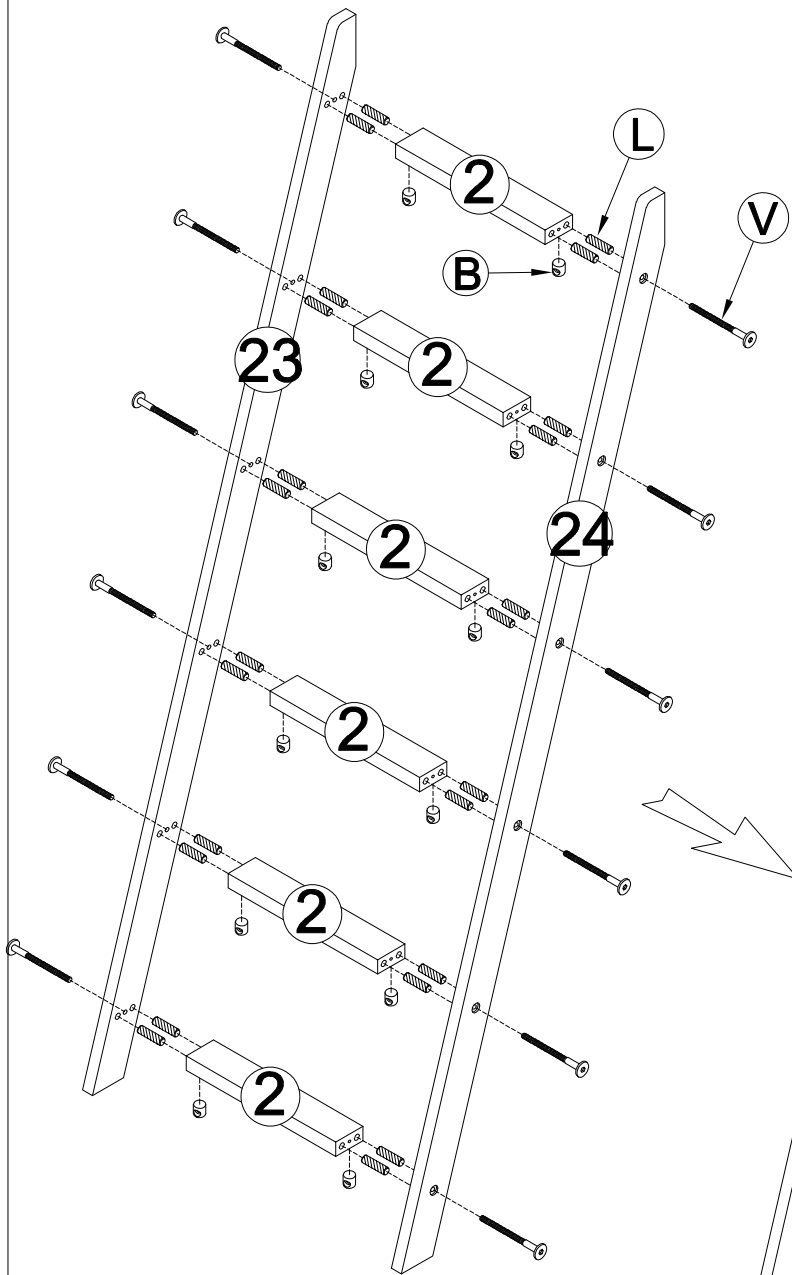

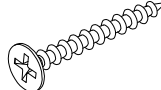
STEP 19:

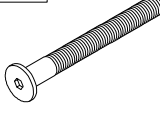

D 	O 	L 
4pcs	2pcs	24pcs
B 	V 	
12pcs	12pcs	

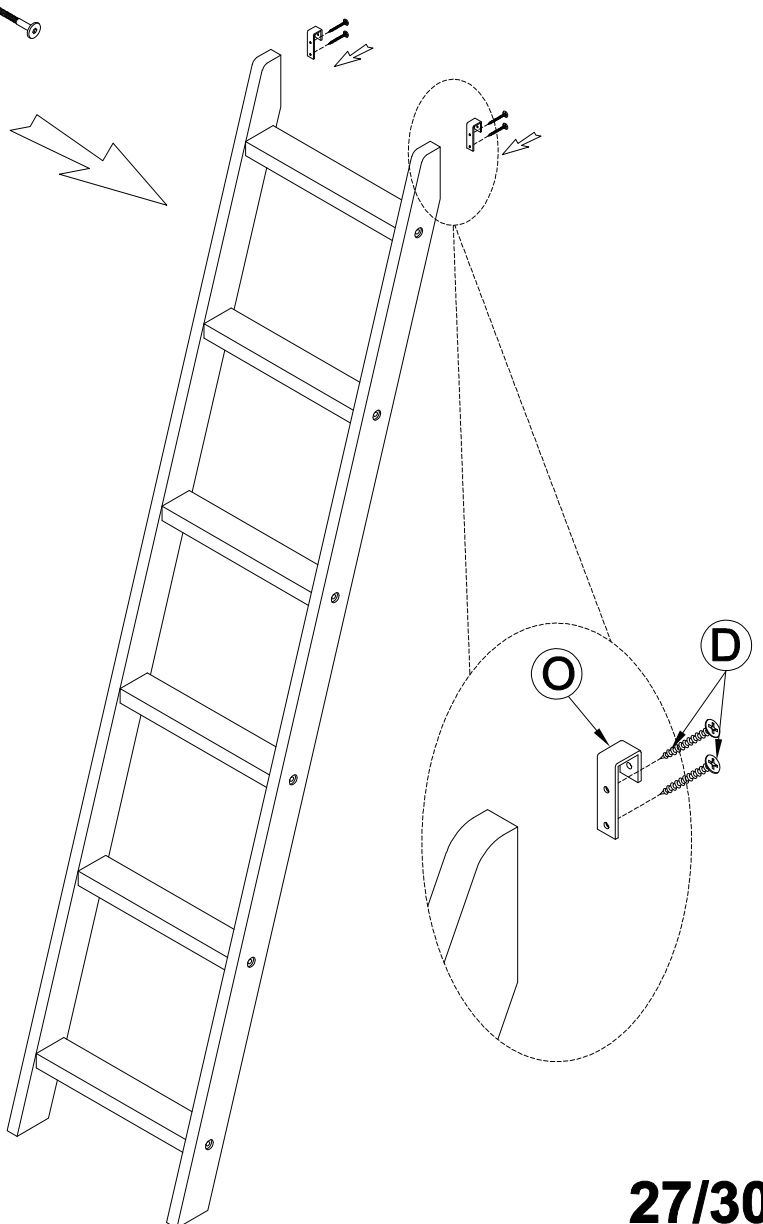

STEP 20:

D

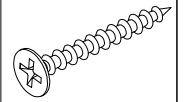

2pcs

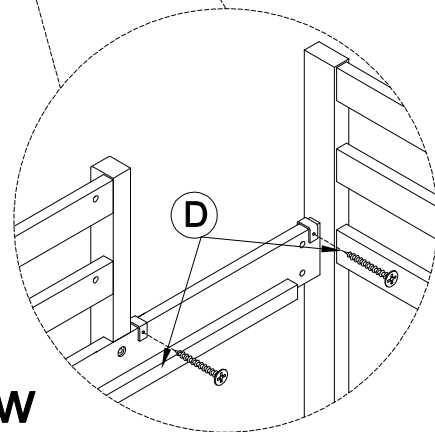
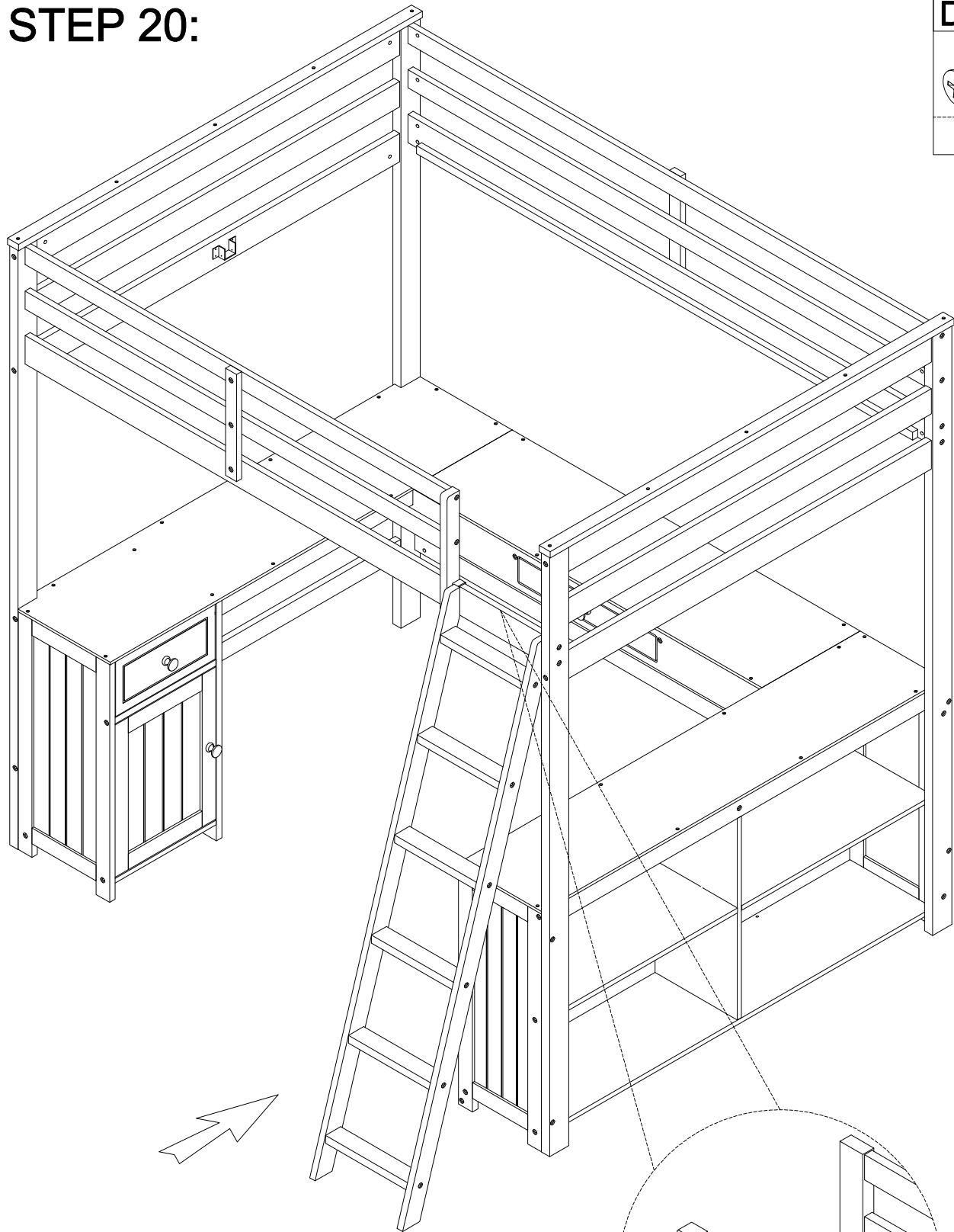

Inside View

STEP 21:

- Put Support 51 into its position and use HW #G connect with bed
- Assembly 14 slats (1) using HW #C.
- Look at detail view

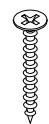
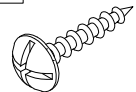
C	
28pcs	
G	
2pcs	

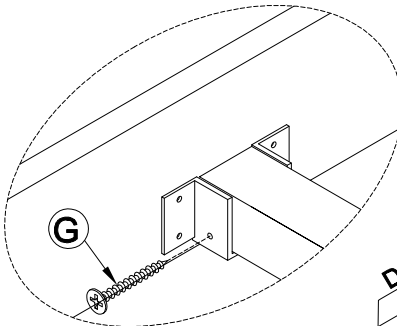

Detail 4(x2)

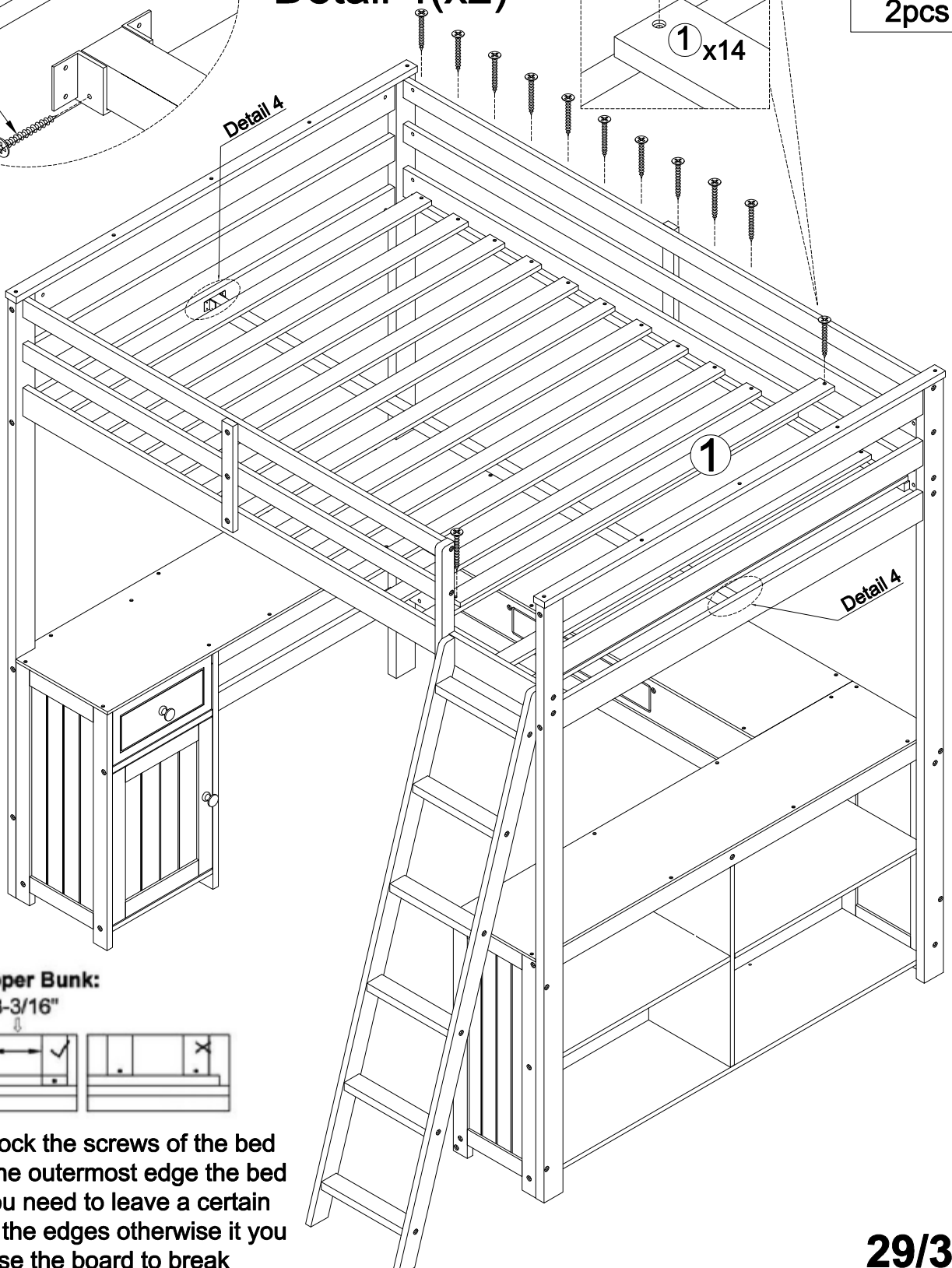
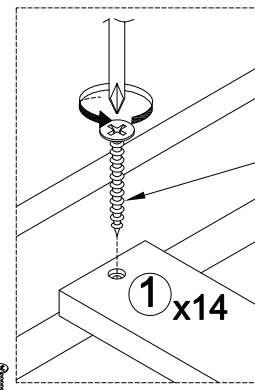

For Upper Bunk:
3-3/16"

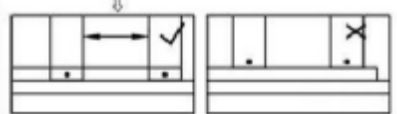

Do not lock the screws of the bed slats to the outermost edge the bed slats, you need to leave a certain space at the edges otherwise it you cause the board to break

CONGRATULATION. YOU HAVE COMPLETED THE BED

