

ASSEMBLY INSTRUCTIONS

FULL LOFT BED WITH SHELF AND CLOSET

LIT LOFT COMPLET AVEC ÉTAGÈRE ET PLACARD

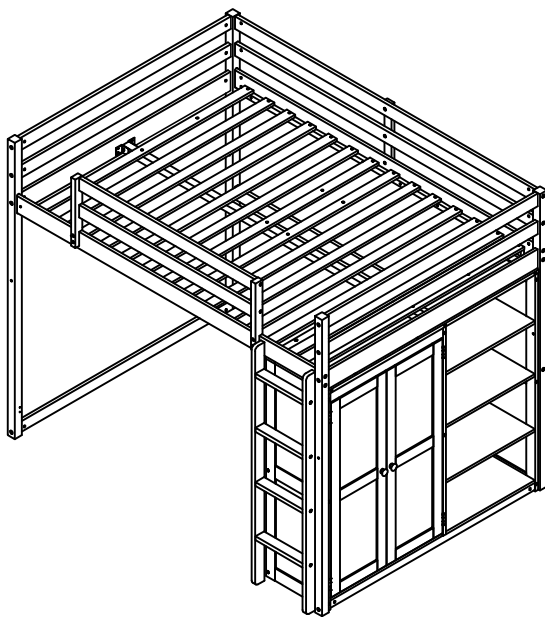

OR

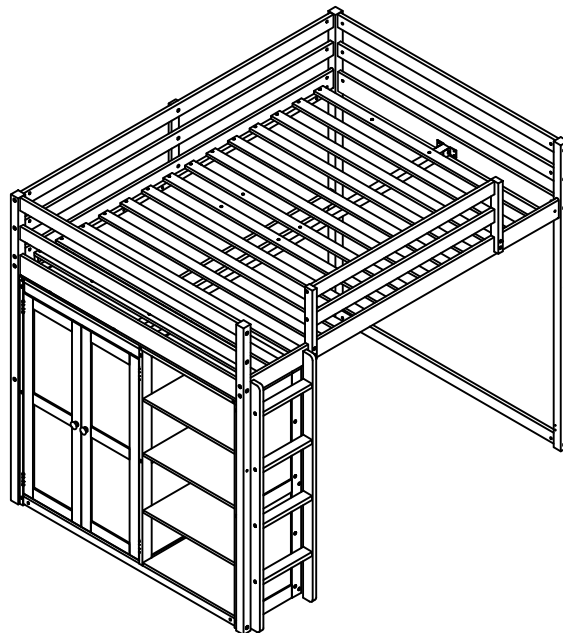

N709P180413/N709P180414

SAFETY WARNINGS AND GENERAL NOTES:

Follow the information on the warnings on the bunk bed end structure and on the carton. Do not remove the warning label from the bed. Always use the recommended size mattress on mattress support, or both, to help prevent the likelihood of entrapment or falls.

The top surface of the mattress must be at least 5*inch (127mm) below the upper edge of the guardrail.

Do not allow children under 6 years of age to use the upper bunk.

Periodically check and ensure the guardrail, ladder and other components are in their proper position, free from damage, and all connectors are tight.

Do not allow horseplay on or under beds.

Always prohibit jumping on the bed.

Prohibit more than one person on upper bunk.

Always use the ladder for entering and leaving the upper bunk.

Do not use substitute parts. Contact the manufacturer or dealer for replacement parts.

Use of a night-light may provide added safety precaution for a child using the upper bunk.

Always use guardrails on both long sides of the upper bunk.

If the bunk bed will be placed next to a wall, the guardrail that runs the full length of the bed should be placed against the wall to prevent entrapment between the bed and the wall.

The use of water or sleep flotation mattresses is prohibited.

STRANGULATION HAZARD-Never attach or hang items to any part of the bunk bed that are not designed for use with the bed.

Keep these instructions for future reference.

We recommend assembling your bunk bed on the shipping carton to protect your floor or carpet.

Be certain all staples are out of the box before beginning assembly on the shipping carton.

THIS BED IS DESIGNED TO USE A FULL MATTRESSES 54" WIDE X 74"-75" LONG WITH THE TOTAL THICKNESS NOT EXCEEDING 6" FOR UPPER BUNK, SURFACE OF MATTRESS MUST BE AT LEAST 5" (127MM) BELOW THE UPPER EDGE OF GUARDRAILS.

Replacement Parts:

Replacement Parts, including additional guardrails, may be obtained from any of our (GIGACLOUD TECHNOLOGY (USA) INC. 4388 SHIRLEY AVE, EL MONTE, CA 91731) dealers.

AVERTISSEMENTS DE SÉCURITÉ ET REMARQUES GÉNÉRALES :

Suivez les informations sur les avertissements figurant sur la structure d'extrémité du lit superposé et sur le carton. Ne retirez pas l'étiquette d'avertissement du lit. Utilisez toujours le matelas de taille recommandée sur le support de matelas, ou les deux, pour éviter tout risque de coincement ou de chute.

La surface supérieure du matelas doit être à au moins 5*poûces (127 mm) sous le bord supérieur du garde-corps.

Ne laissez pas les enfants de moins de 6 ans utiliser le lit supérieur.

Vérifiez périodiquement et assurez-vous que le garde-corps, l'échelle et les autres composants sont dans leur bonne position, exempts de dommages et que tous les connecteurs sont bien serrés.

Ne permettez pas les chahuts sur ou sous les lits.

Interdisez toujours de sauter sur le lit.

Interdire plus d'une personne sur la couchette supérieure.

Utilisez toujours l'échelle pour entrer et sortir du lit supérieur.

N'utilisez pas de pièces de rechange. Contactez le fabricant ou le revendeur pour obtenir des pièces de rechange.

L'utilisation d'une veilleuse peut fournir une précaution supplémentaire en matière de sécurité pour un enfant utilisant le lit supérieur.

Utilisez toujours des garde-corps sur les deux côtés longs du lit supérieur.

Si le lit superposé doit être placé à côté d'un mur, le garde-corps qui s'étend sur toute la longueur du lit doit être placé contre le mur pour éviter tout coincement entre le lit et le mur.

L'utilisation de matelas flottants à eau ou de sommeil est interdite.

RISQUE D'ÉTRANGULATION - N'attachez ou ne suspendez jamais d'objets à une partie du lit superposé qui ne sont pas conçus pour être utilisés avec le lit.

Conservez ces instructions pour référence future.

Nous vous recommandons d'assembler votre lit superposé sur le carton d'expédition pour protéger votre sol ou votre tapis.

Assurez-vous que toutes les agrafes sont sorties de la boîte avant de commencer l'assemblage sur le carton d'expédition.

CE LIT EST CONÇU POUR UTILISER UN MATELAS COMPLET DE 54" DE LARGE X 74" - 75" DE LONG AVEC L'ÉPAISSEUR TOTALE NE DÉPASSANT PAS 6" POUR LE COUCHE SUPÉRIEUR, LA SURFACE DU MATELAS DOIT ÊTRE AU MOINS 5" (127 MM) EN DESSOUS DU BORD SUPÉRIEUR DES GARDE-CORPS.

Pièces de rechange :

Les pièces de rechange, y compris les garde-corps supplémentaires, peuvent être obtenues auprès de l'un de nos revendeurs (GIGACLOUD TECHNOLOGY (USA) INC. 4388 SHIRLEY AVE, EL MONTE, CA 91731).

Detail View



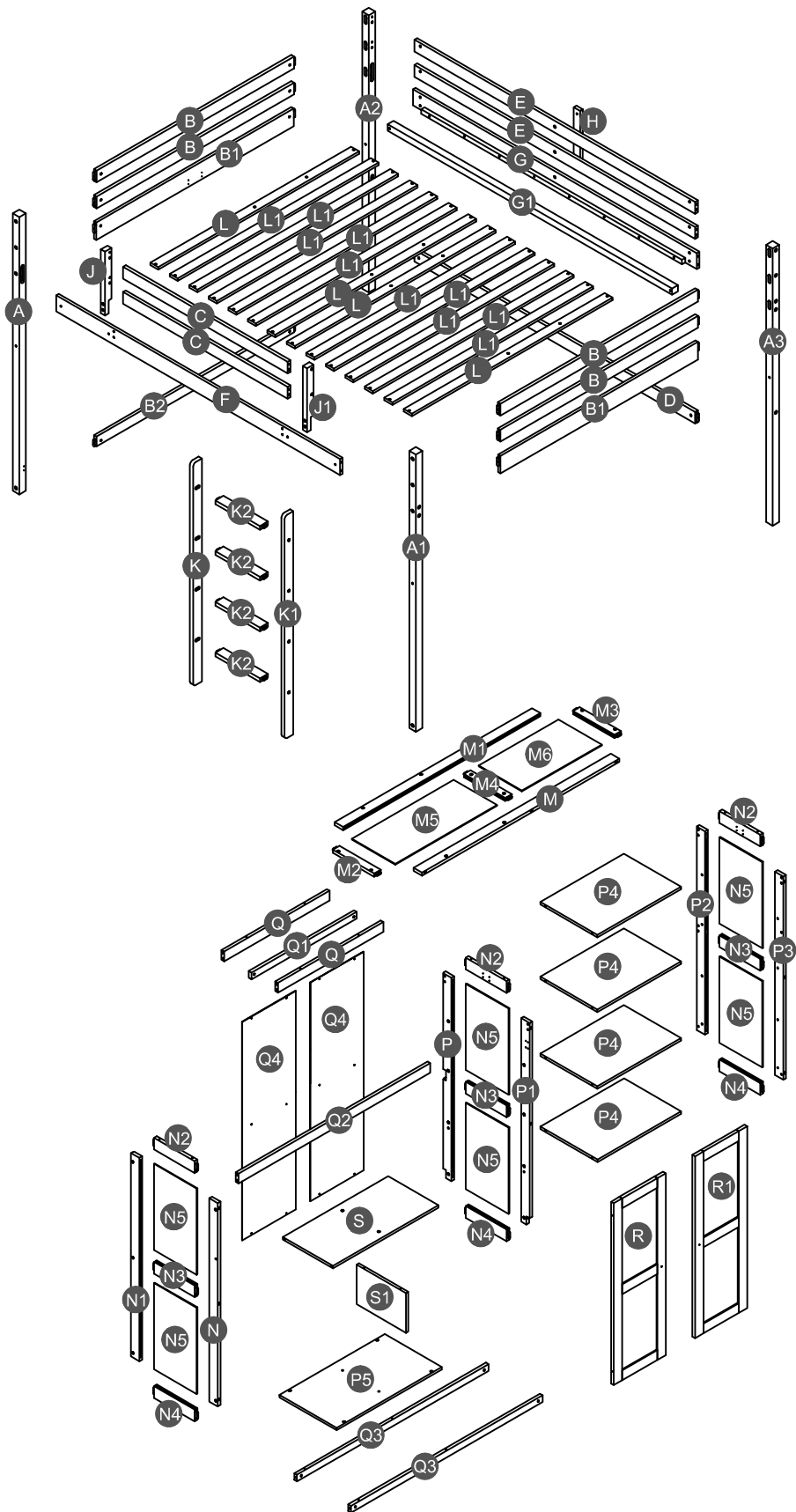







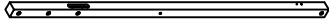
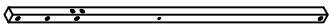
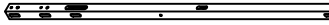
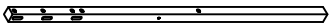
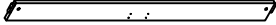



Vue Détaillée

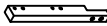
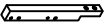
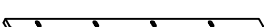

Part List

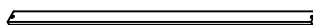
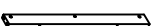
Liste des Pièces











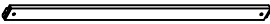

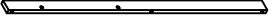



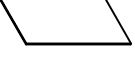
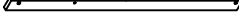

N709P180413

<p>A</p>  <p>Leg (Left Front) - 1pc Pied (Avant gauche)</p>	<p>A1</p>  <p>Leg (Right Front) - 1pc Pied (Avant droit)</p>	<p>A2</p>  <p>Leg (Left Back) - 1pc Pied (Arrière gauche)</p>
<p>A3</p>  <p>Leg (Right Back) - 1pc Pied (Arrière droit)</p>	<p>B1</p>  <p>Divider horizontal bar HB/FB -2pcs Barre horizontale de séparation HB/FB</p>	<p>C</p>  <p>Short guard rail (Front) - 2pcs Garde-corps court (Avant)</p>
<p>D</p>  <p>Lower horizontal bar (Back) - 1pc Barre horizontale inférieure (arrière)</p>	<p>E</p>  <p>Long guard rail (Back) - 2pcs Garde-corps long (Arrière)</p>	<p>F</p>  <p>Side rail (Front) - 1pc Rail latéral (Avant)</p>
<p>G</p>  <p>Side rail (Back) - 1pc Rail latéral (Arrière)</p>	<p>G1</p>  <p>Lower support slat - 1pc Latte de support inférieure</p>	<p>J</p>  <p>Vertical guard rail (Left) - 1pc Garde-corps vertical (Gauche)</p>
<p>J1</p>  <p>Vertical guard rail (Right) - 1pc Garde-corps vertical (Droite)</p>	<p>K</p>  <p>Ladder (left) - 1pc Échelle (gauche)</p>	<p>K1</p>  <p>Ladder (right) - 1pc Échelle (droite)</p>
<p>K2</p>  <p>Step ladder - 4pcs Escabeau</p>	<p>L</p>  <p>Slats - 4pcs Latte</p>	<p>L1</p>  <p>Slats - 10pcs Latte</p>
<p>Q</p>  <p>Upper horizontal bar - 2pcs Barre horizontale supérieure</p>	<p>Q3</p>  <p>Lower horizontal bar - 2pcs Barre horizontale inférieure</p>	<p>S</p>  <p>Shelf panel (Left) - 1pc Panneau d'étagère (gauche)</p>
<p>S1</p>  <p>Divider panel (Left) - 1pc Panneau d'étagère (gauche)</p>		

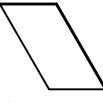
Part List

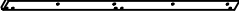
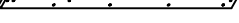
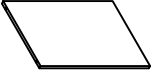

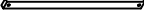
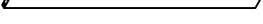
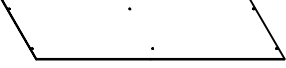

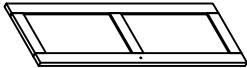



Liste des Pièces

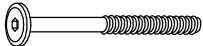



N709P180414 + Hardware inside/Matériel à l'intérieur

<p>B</p>  <p>Upper horizontal bar HB/FB - 4pcs Barre horizontale supérieure HB/FB</p>	<p>B2</p>  <p>Lower horizontal bar HB - 1pc Barre horizontale inférieure HB</p>	<p>H</p>  <p>Vertical guard rail (Back) - 1pc Garde-corps vertical (Arrière)</p>
<p>M</p>  <p>Upper horizontal bar (Front) - 1pc Barre horizontale supérieure (avant)</p>	<p>M1</p>  <p>Upper horizontal bar (Back) - 1pc Barre horizontale supérieure (Arrière)</p>	<p>M2</p>  <p>Upper horizontal bar (Left) - 1pc Barre horizontale supérieure (gauche)</p>
<p>M3</p>  <p>Upper horizontal bar (Right) - 1pc Barre horizontale supérieure (droite)</p>	<p>M4</p>  <p>Upper horizontal bar (Divider)- 1pc Barre horizontale supérieure (Diviseur)</p>	<p>M5</p>  <p>Upper panel (Left) - 1pc Panneau supérieur (gauche)</p>
<p>M6</p>  <p>Upper panel (Right) - 1pc Panneau supérieur (droite)</p>	<p>N</p>  <p>Vertical bar (Left Front) - 1pc Barre verticale (Avant gauche)</p>	<p>N1</p>  <p>Vertical bar (Left Back) - 1pc Barre verticale (Arrière gauche)</p>
<p>N2</p>  <p>Upper horizontal bar - 3pcs Barre horizontale supérieure</p>	<p>N3</p>  <p>Divider horizontal bar - 3pcs Barre horizontale de séparation</p>	<p>N4</p>  <p>Lower horizontal bar - 3pcs Barre horizontale inférieure</p>
<p>N5</p>  <p>Side panel - 6pcs Barre horizontale supérieure</p>	<p>P</p>  <p>Divider vertical bar (Back) - 1pc Barre verticale de séparation (arrière)</p>	<p>P1</p>  <p>Divider vertical bar (Front) - 1pc Barre verticale de séparation (avant)</p>
<p>P2</p>  <p>Vertical bar (Right Back) - 1pc Barre verticale (Arrière droit)</p>	<p>P3</p>  <p>Vertical bar (Right Front) - 1pc Barre verticale (Avant droit)</p>	<p>P4</p>  <p>Shelf panel (Right) - 1pc Panneau d'étagère (droite)</p>
<p>P5</p>  <p>Bottom panel (Left) - 1pc Panneau inférieur (gauche)</p>	<p>Q1</p>  <p>Hanging bar - 1pc Barre suspendue</p>	<p>Q2</p>  <p>Divider horizontal bar (Back) - 1pc Barre horizontale de séparation (arrière)</p>
<p>Q4</p>  <p>Back panel - 2pcs Panneau arrière</p>	<p>R</p>  <p>Door (Left) - 1pc Porte (gauche)</p>	<p>R1</p>  <p>Door (Right) - 1pc Porte (droite)</p>

Hardware List N709P180414

Liste des Accessoires

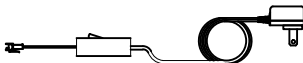
<p>1</p>  <p>Ø10*40mm</p> <p>Wood dowel (8pcs) Cheville en bois</p>	<p>2</p>  <p>Ø8*30mm</p> <p>Wood dowel (11pcs) Cheville en bois</p>	<p>3</p>  <p>(Ø15)1/4"*100mm</p> <p>Hex-Head bolts (16pcs) Boulons à tête hexagonale</p>
<p>4</p>  <p>(Ø15)1/4"*80mm</p> <p>Hex-Head bolts (18pcs) Boulons à tête hexagonale</p>	<p>5</p>  <p>(Ø12)1/4"*60mm</p> <p>Hex-Head bolts (34pcs) Boulons à tête hexagonale</p>	<p>6</p>  <p>(Ø12)1/4"*40mm</p> <p>Hex-Head bolts (4pcs) Boulons à tête hexagonale</p>
<p>7</p>  <p>(Ø12)1/4"*35mm</p> <p>Hex-Head bolts (4pcs) Boulons à tête hexagonale</p>	<p>8</p>  <p>(Ø12)1/4"*30mm</p> <p>Hex-Head bolts (3pcs) Boulons à tête hexagonale</p>	<p>9</p>  <p>(Ø12)1/4"*15mm</p> <p>Hex-Head bolts (2pcs) Boulons à tête hexagonale</p>
<p>10</p>  <p>1/4"*15 (9.5mm)</p> <p>Horizontal-Hole bolts(66pcs) Boulons à trou horizontal</p>	<p>11</p>  <p>(Ø12)1/4"*65mm</p> <p>Hex-Head bolts (21pcs) Boulons à tête hexagonale</p>	<p>12</p>  <p>(Ø12)1/4"*50mm</p> <p>Hex-Head bolts (3pcs) Boulons à tête hexagonale</p>
<p>13</p>  <p>(Ø12)1/4"*40mm</p> <p>Hex-Head bolts (18pcs) Boulons à tête hexagonale</p>	<p>14</p>  <p>Ø4*30mm</p> <p>Wood screws (34pcs) Vis</p>	<p>15</p>  <p>Ø3.5*15mm</p> <p>Wood screws (12pcs) Vis</p>
<p>16</p>  <p>Ø3.5*15mm</p> <p>Wood screws (53pcs) Vis</p>	<p>17</p>  <p>(Ø13)1/4"*14mm</p> <p>Connect bolt (4pcs) Connecter le boulon</p>	<p>18</p>  <p>Ø38*31mm</p> <p>Pine Knob (2pcs) Bouton en pin</p>
<p>19</p>  <p>3/16"*25mm</p> <p>Ph zinc(Knob) (2pcs) Ph zinc (bouton)</p>	<p>20</p>  <p>70*37*28mm (135°)</p> <p>Door hinge (4pcs) Charnière de porte</p>	<p>21</p>  <p>42*12*1mm</p> <p>Metal magnet (2pcs) Aimant en métal</p>
<p>22</p>  <p>63*40*30*1.2mm</p> <p>Metal bracket (2pcs) Support métallique</p>	<p>23</p>  <p>120*41*21mm</p> <p>Stopper door (1pc) Butée de porte</p>	<p>24</p>  <p>116*40*27mm</p> <p>Metal bracket (2pcs) Support métallique</p>

25  50*24*24*2mm	26  L1900mm	27  L3000mm
Metal bracket (1pc) Support métallique	Led light (1pc) Lumière LED	Adapter and wire strip (1pc) Adaptateur et barrette de fil
28  22*10*6mm	29  (1/4")4.5*58mm	
Clamp plastic (1pc) Pince en plastique	Allen key (2pcs) Clé Allen	

ASSEMBLY TOOLS REQUIRED (NOT INCLUDED)

OUTILS D'ASSEMBLAGE REQUIS (NON INCLUS)

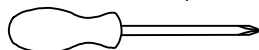

(Phillip head screwdriver)



PLEASE BE CAREFUL DO NOT DAMAGE THE HOLE POSITION WHEN YOU USE POWER TOOLS !

NE PAS UTILISEZ DES OUTILS ÉLECTRIQUES POUR ASSEMBLER CE PRODUIT !

STEP 1:
ÉTAPE

TYPE 1
TAPER

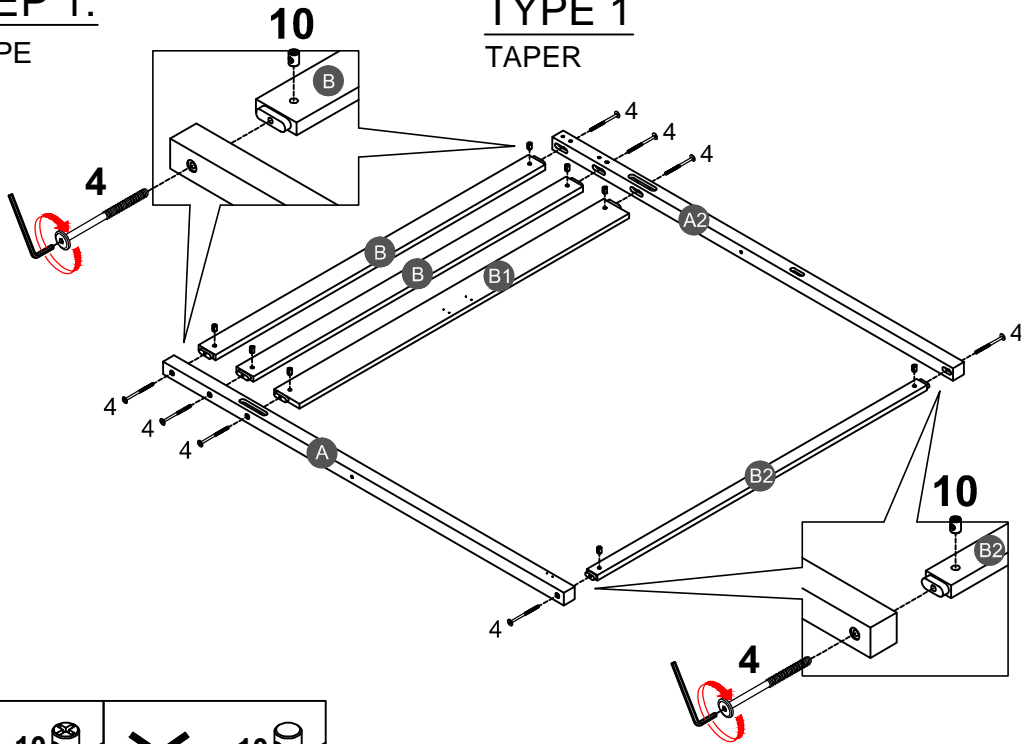

4	
	8PCS
10	
	8PCS

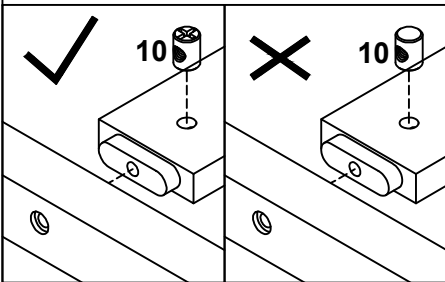

Note: Part 10 will face up with the "x" mark on it, otherwise it cannot be tightened

Remarque: La pièce 10 sera face vers le haut avec la marque "x", sinon elle ne peut pas être serrée.

STEP 2:
ÉTAPE

TYPE 1
TAPER

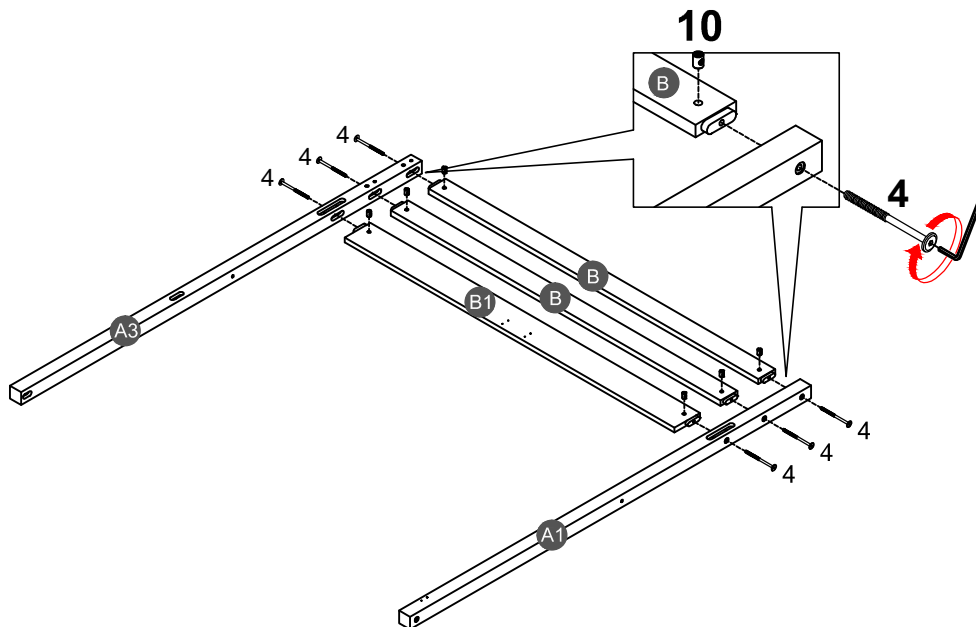



4	
	6PCS
10	
	6PCS

STEP 3:
ÉTAPE

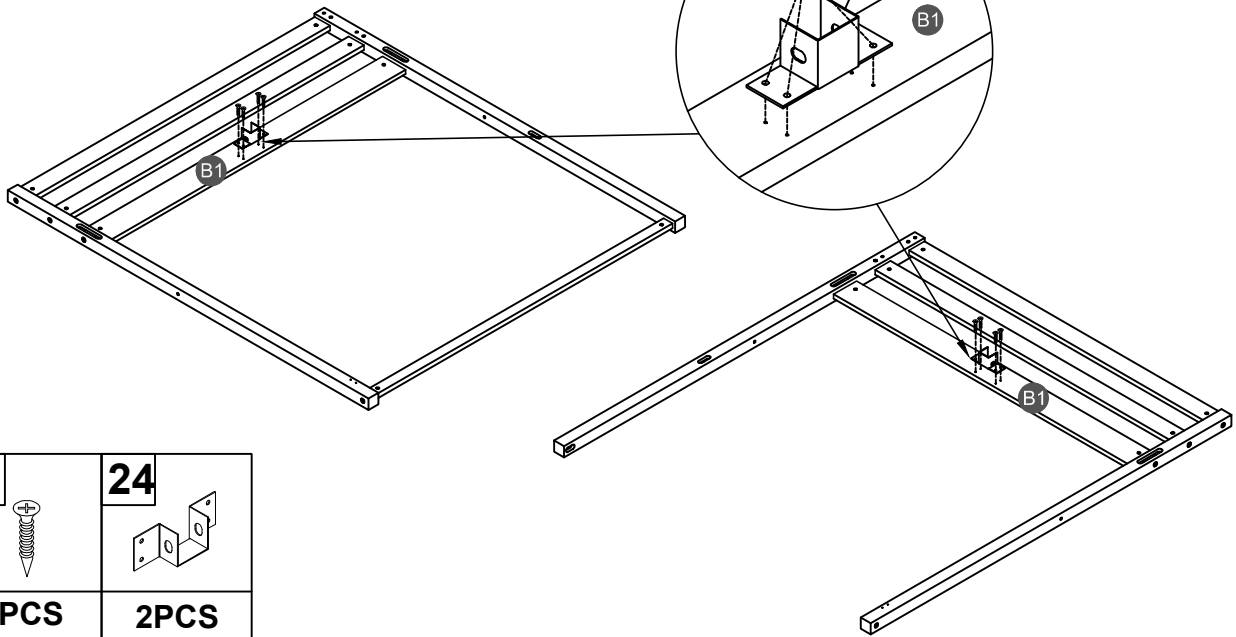
TYPE 1
TAPER





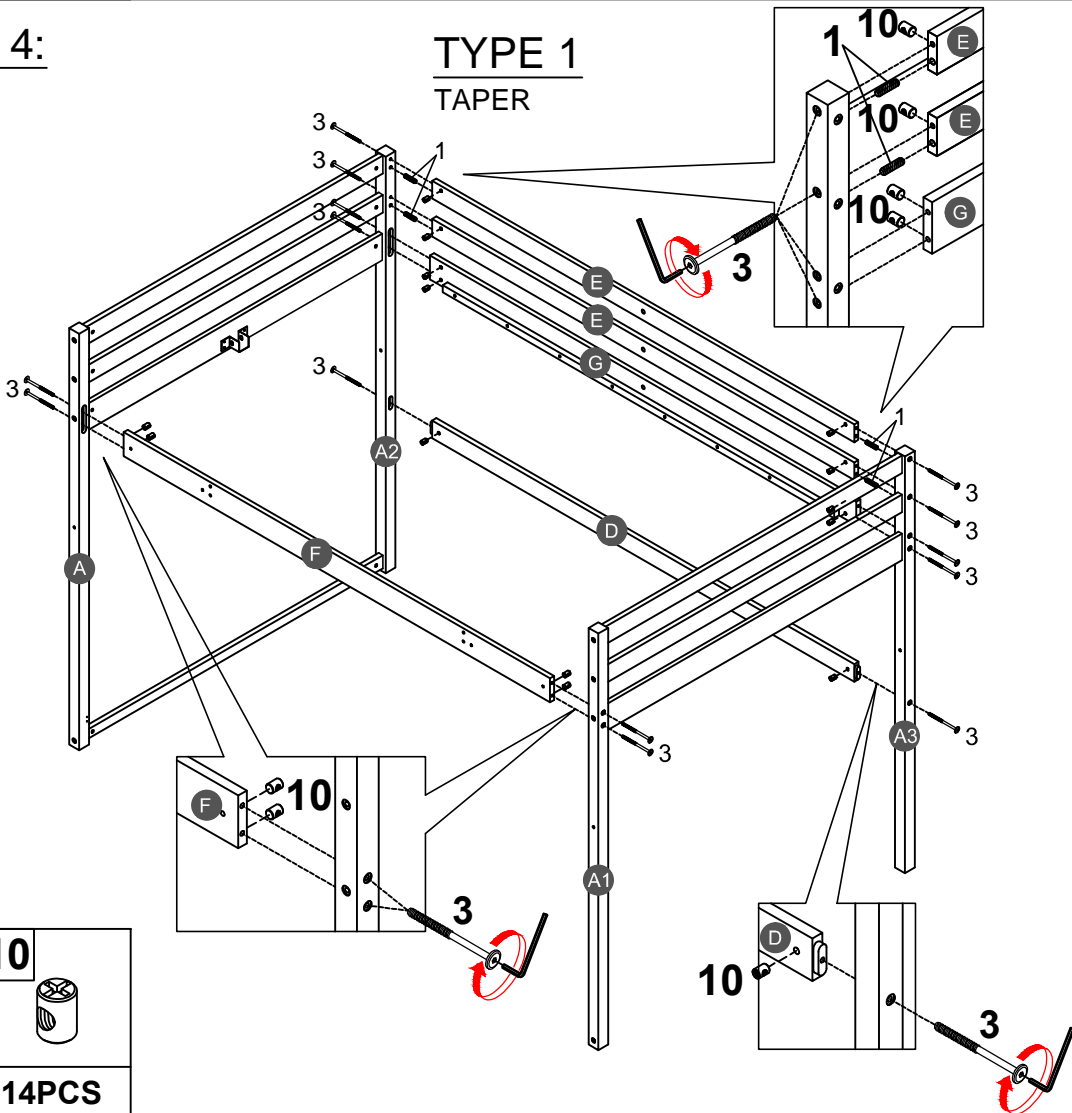

16 	24 
8PCS	2PCS

STEP 4:
ÉTAPE

TYPE 1
TAPER



1 	10 
4PCS	14PCS
3 	10 
14PCS	14PCS

STEP 5:
ÉTAPE

TYPE 1
TAPER

8



3PCS

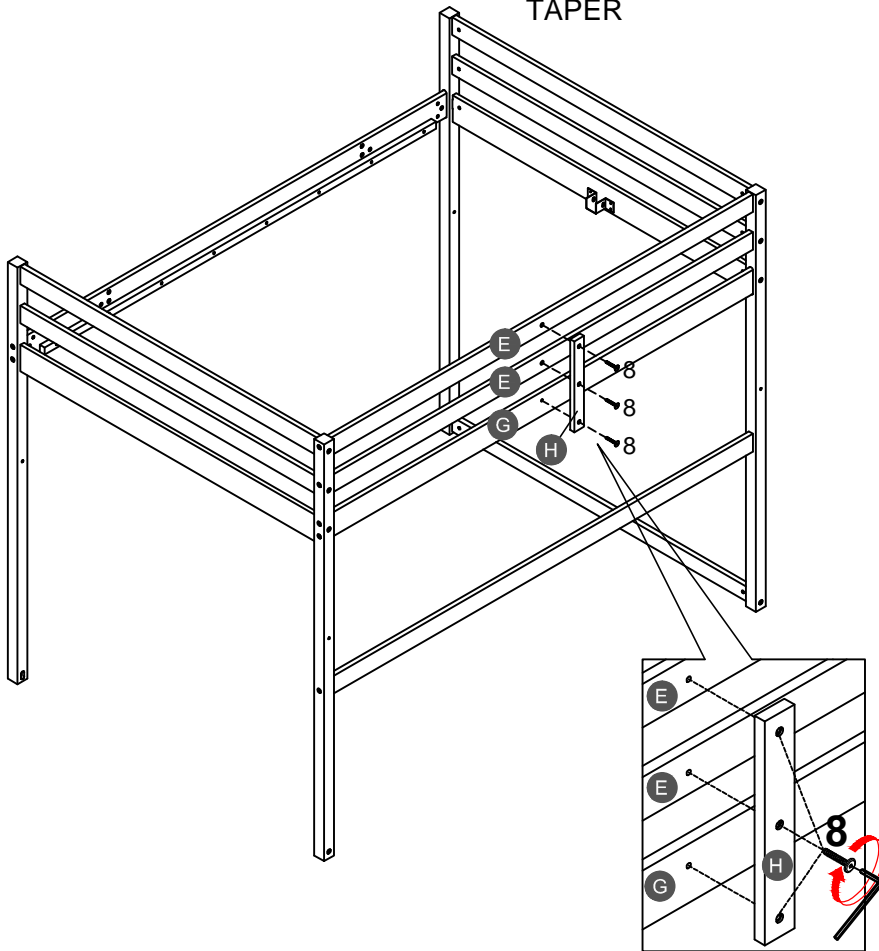

STEP 6:
ÉTAPE

TYPE 1
TAPER

1



4PCS

4

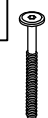

4PCS

10



4PCS

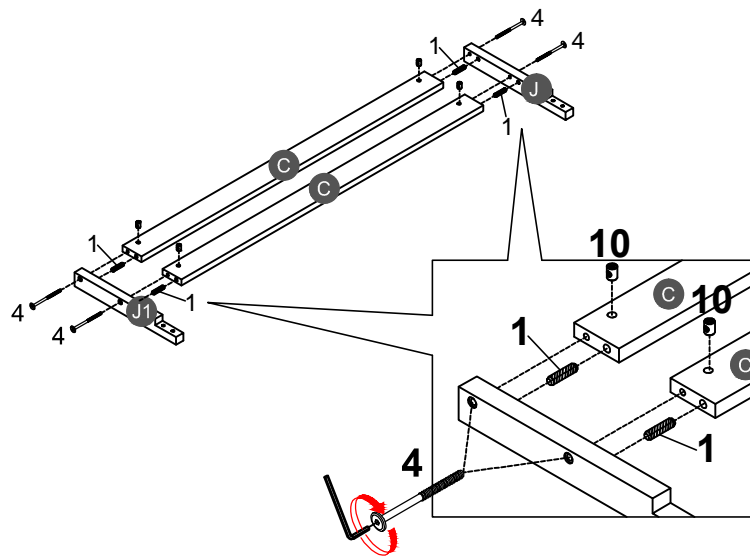

STEP 7:

ÉTAPE

TYPE 1

TAPER

7



4PCS

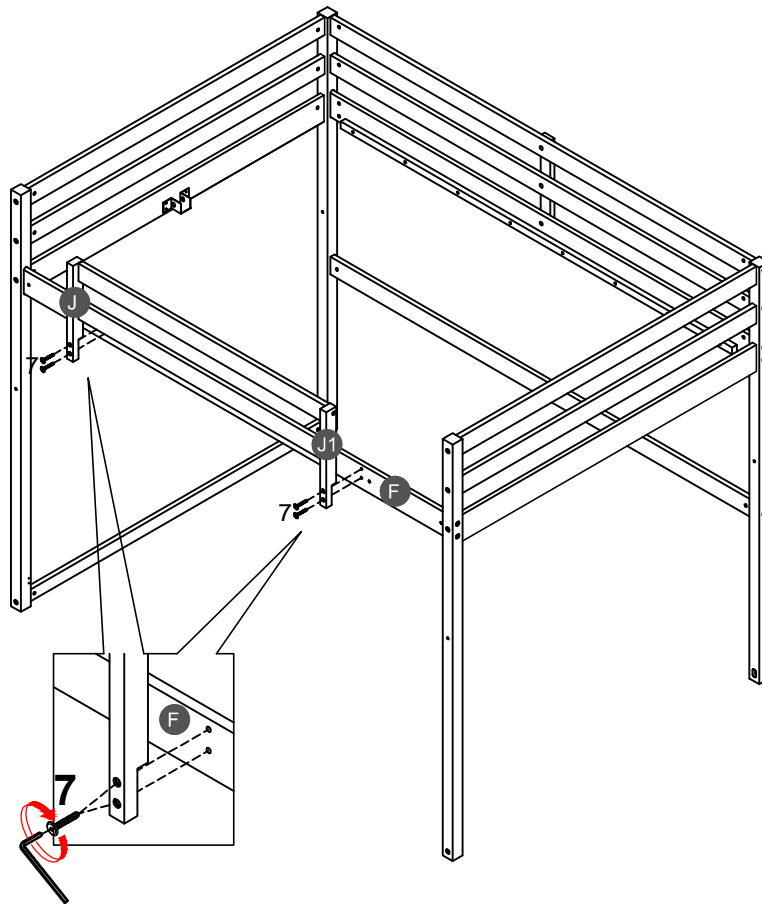

STEP 8:

ÉTAPE

TYPE 1

TAPER

5	10	16	25
8PCS	8PCS	2PCS	1PC

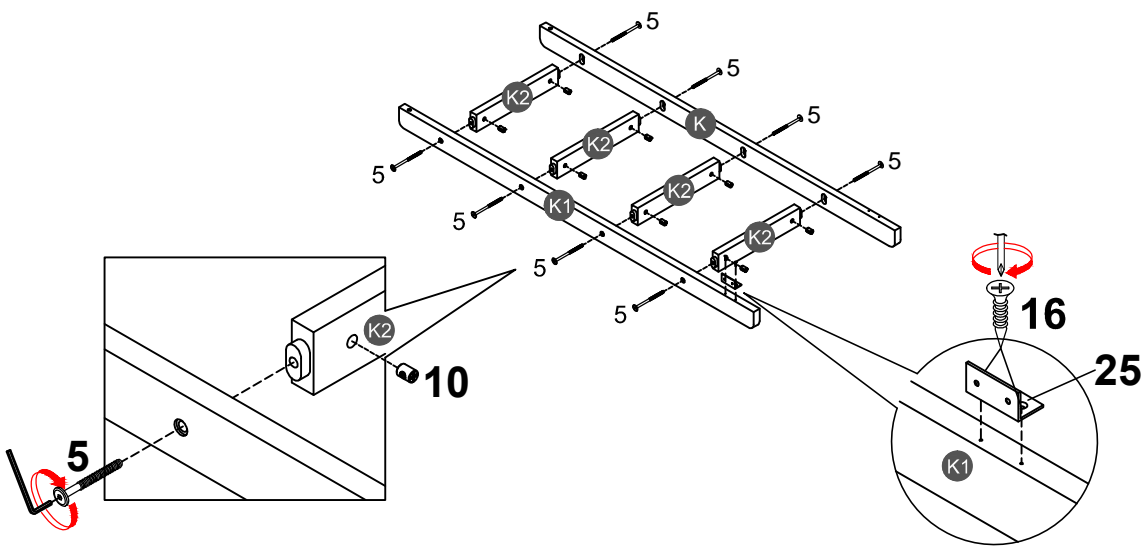

STEP 9:
ÉTAPE

TYPE 1
TAPER

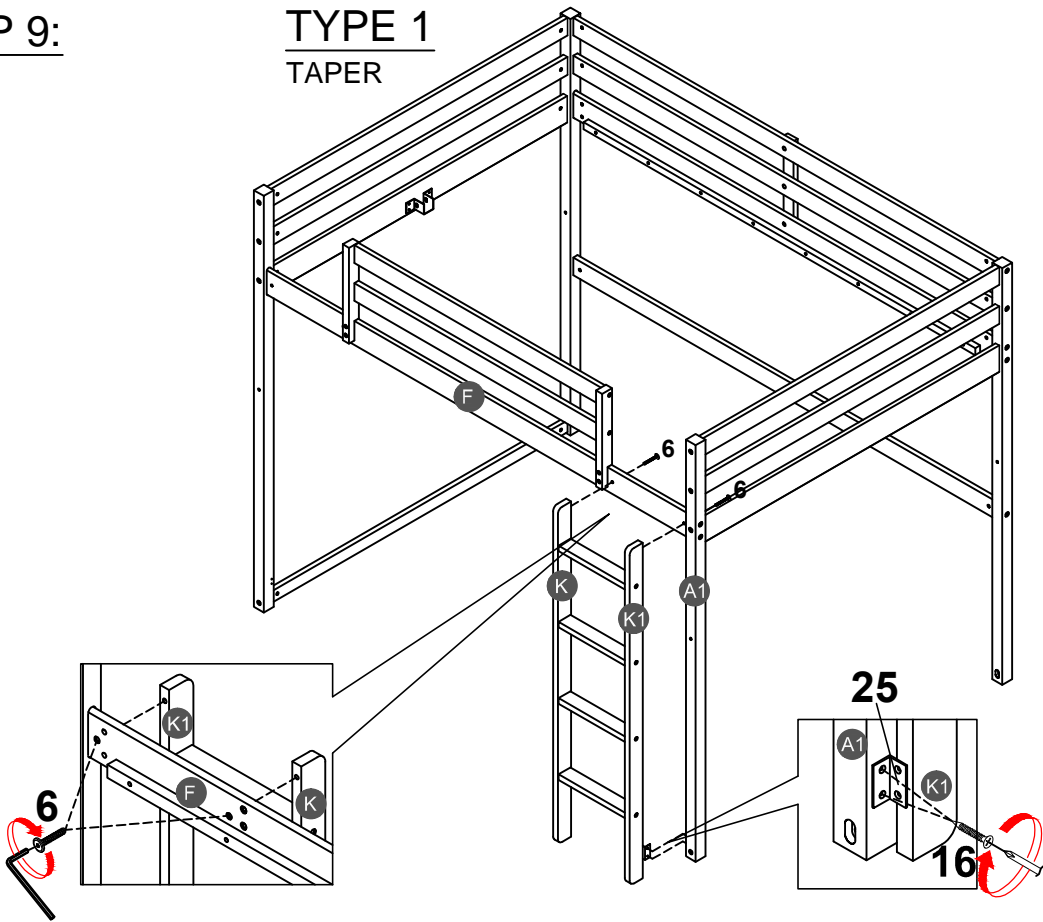

6



2PCS

16



2PCS

STEP 10:
ÉTAPE

TYPE 1
TAPER

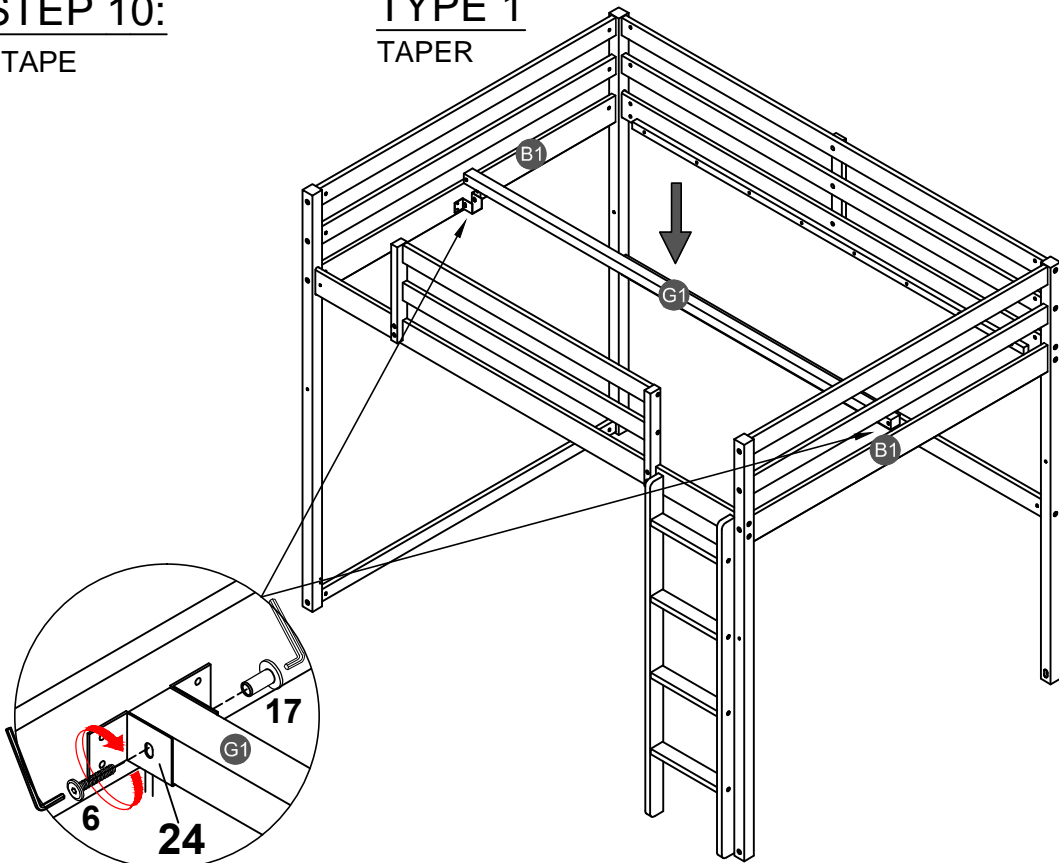

6



2PCS

17





2PCS

STEP 11:

ÉTAPE

TYPE 1

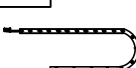
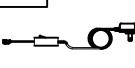
TAPER

16 	26 	27 	28 
1PC	1PC	1PC	1PC

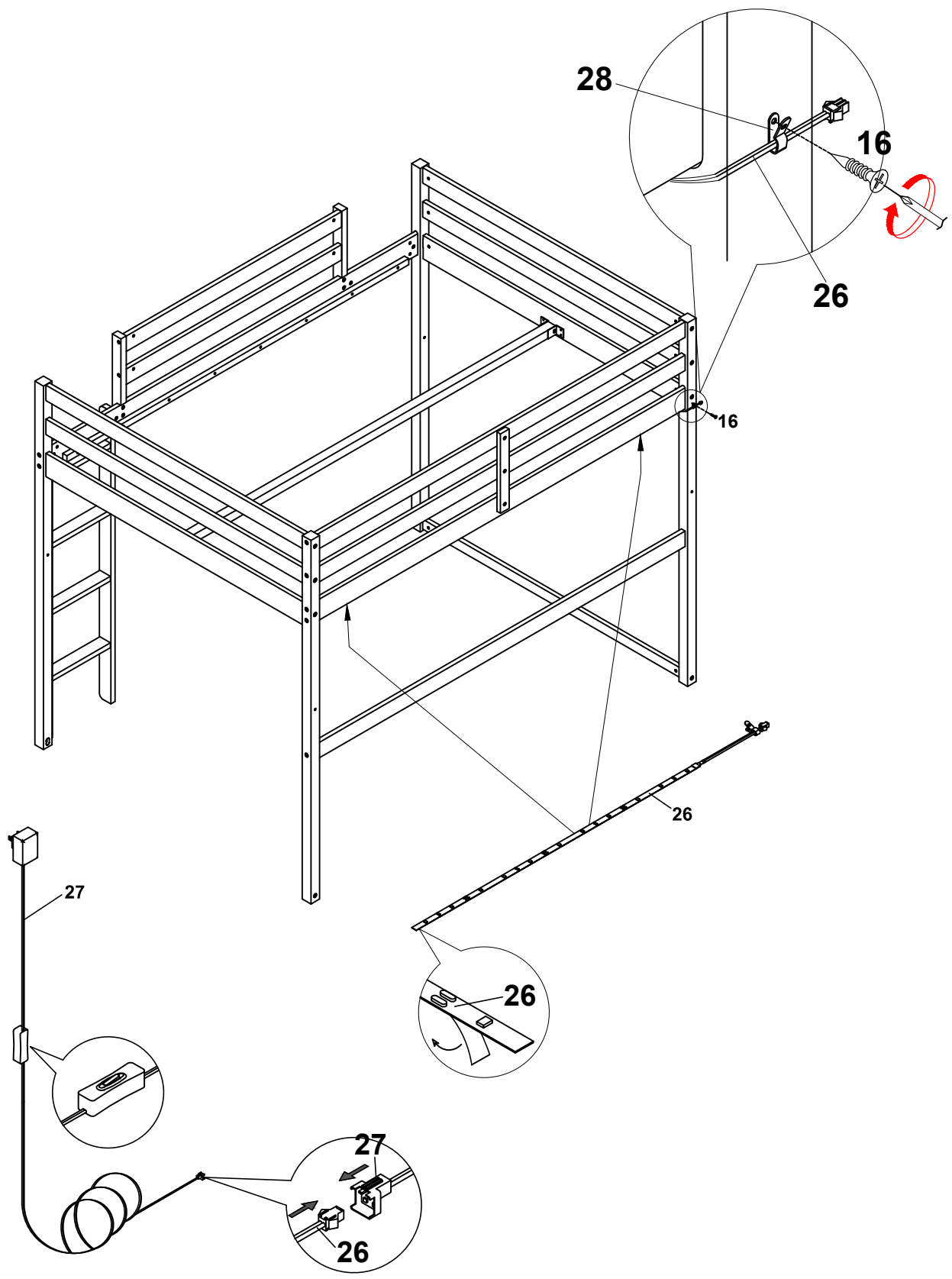

STEP 12:

ÉTAPE

TYPE 1

TAPER

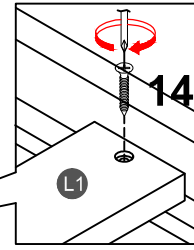

14



32PCS

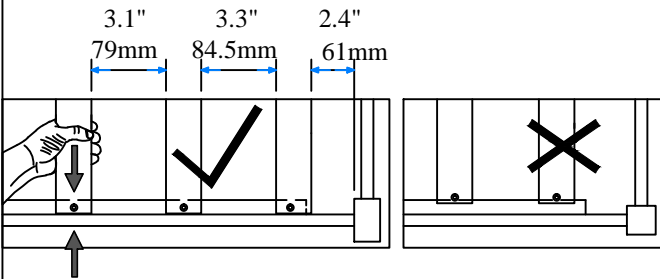
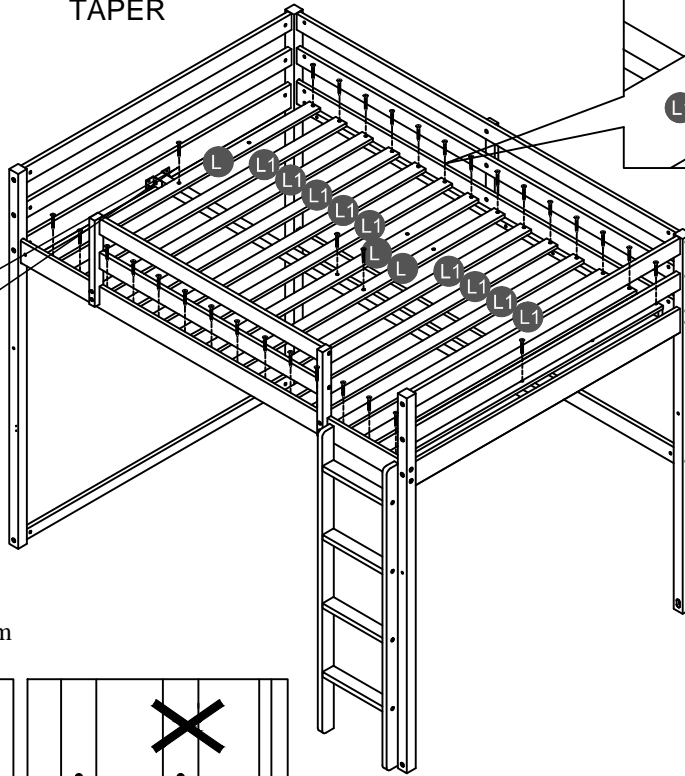
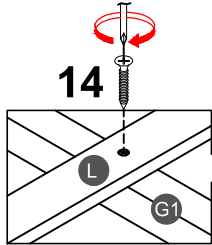

NOTE: Please make sure the bed slats close to the side rail before locking the screws to avoid breakage. This step is required for both the left and right sides. Moreover, please do not lock the screws of the bed slats at the outermost edge to avoid damaging.

Remarque: Assurez-vous Les lattes du lit fermer du rail latéral avant de verrouiller les vis pour éviter la casse. Cette étape est requise pour tous les deux côtés gauche et droit. De plus, ne verrouillez pas les vis des lattes de lit sur le bord le plus extérieur pour éviter d'endommager.

STEP 13:

ÉTAPE

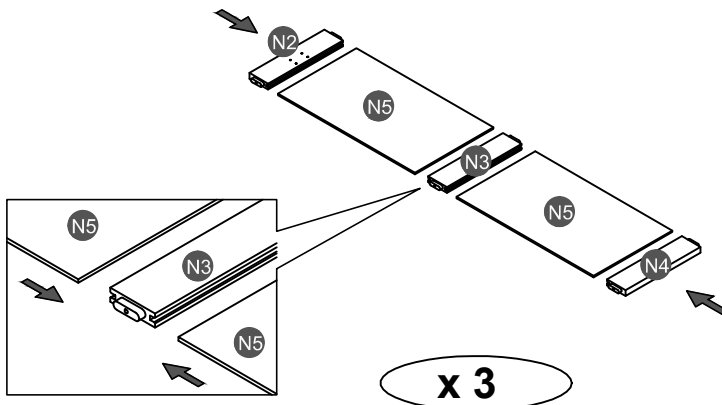

STEP 14:

ÉTAPE

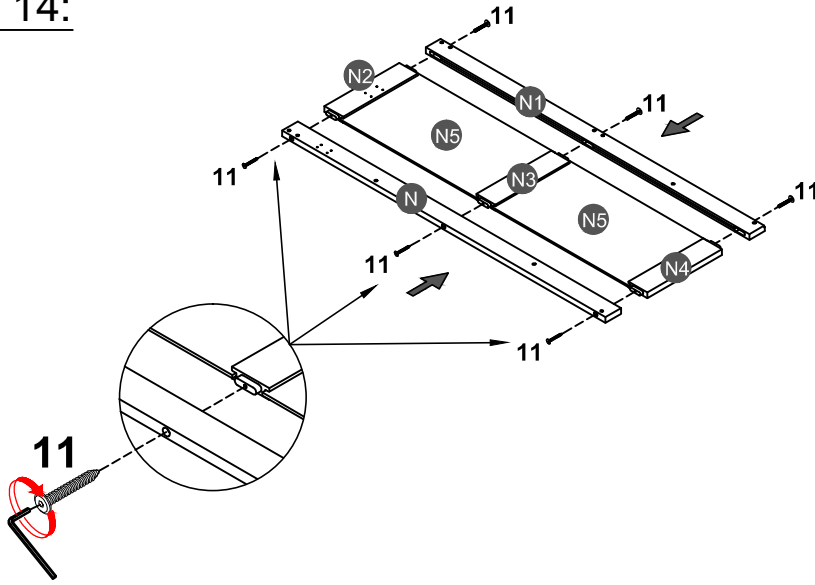

11



6PCS

STEP 15:

ÉTAPE

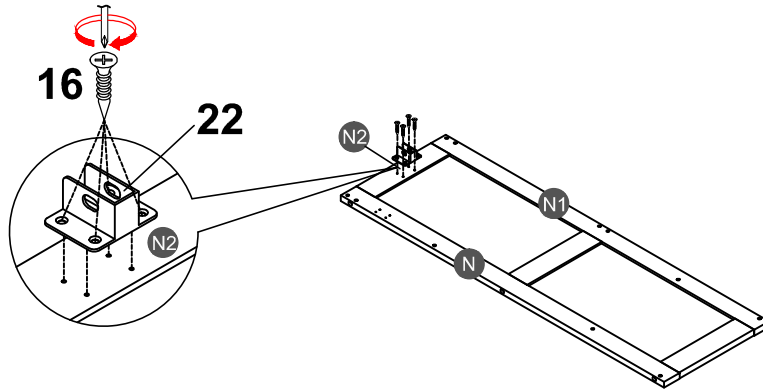

16



4PCS

22



1PC

STEP 16:

ÉTAPE

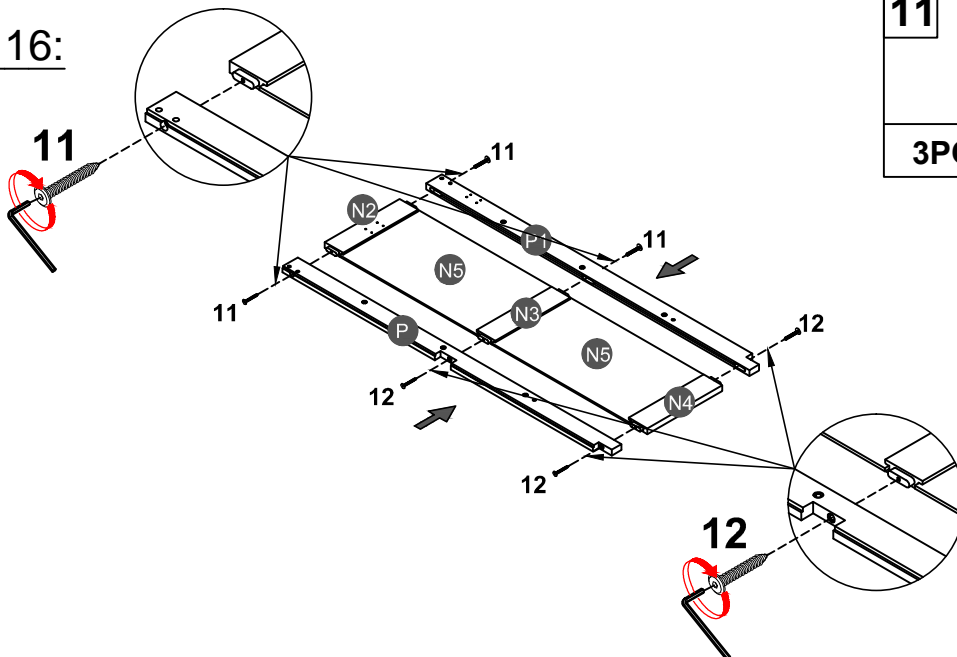

11



3PCS



12



3PCS

STEP 17:

ÉTAPE

16		22	
4PCS		1PC	

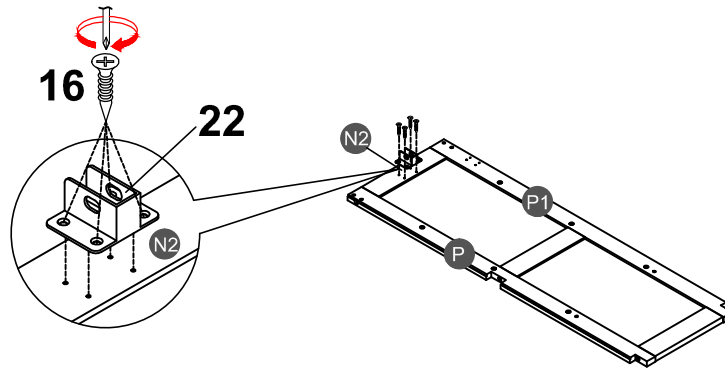

STEP 18:

ÉTAPE

11	
6PCS	

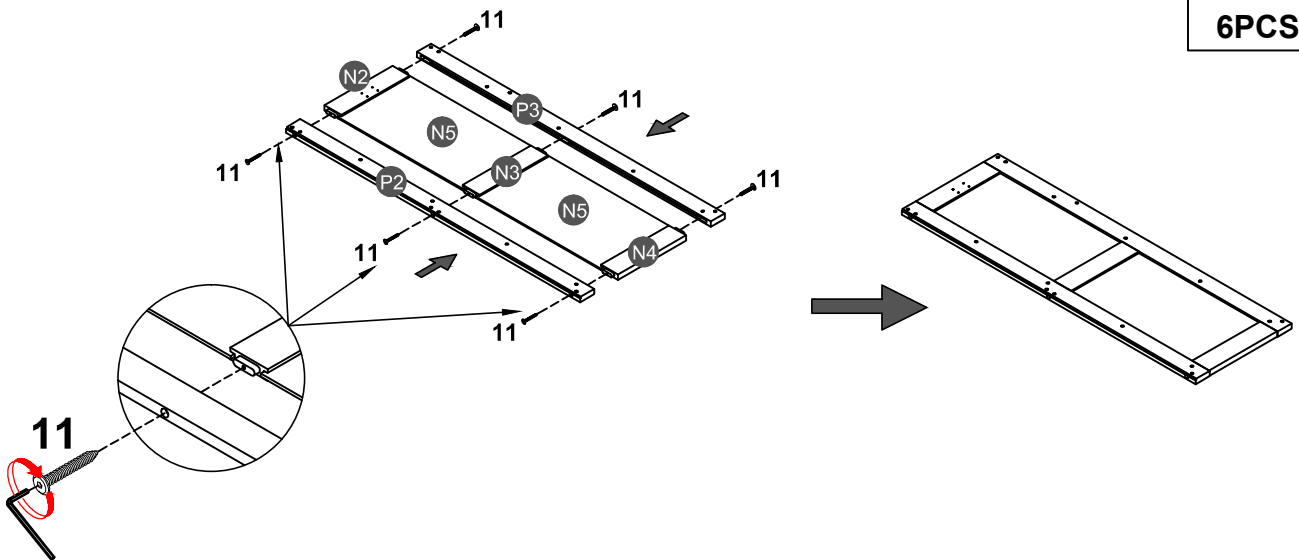

STEP 19:

ÉTAPE

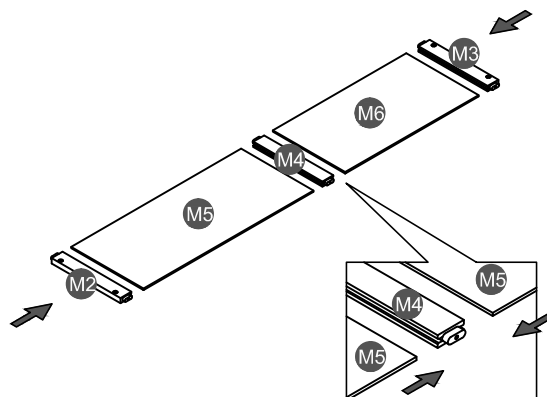

STEP 20:

ÉTAPE

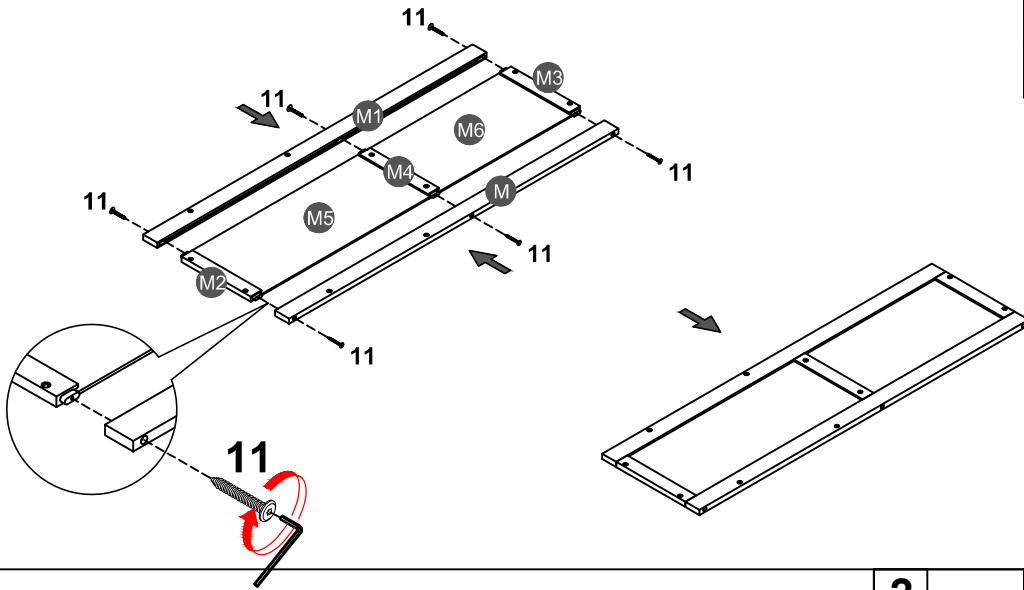



11	
6PCS	

STEP 21:

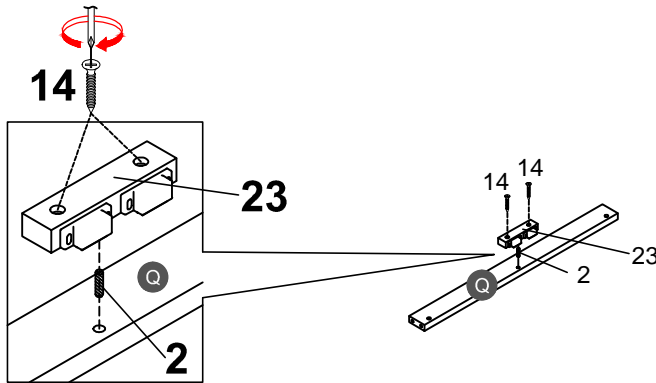
ÉTAPE



2		14	
1PC		2PCS	
		23	
		1PC	

STEP 22:

ÉTAPE

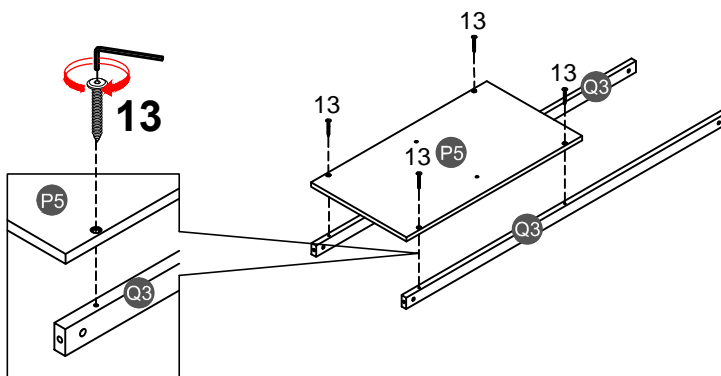

13	
4PCS	

STEP 23:

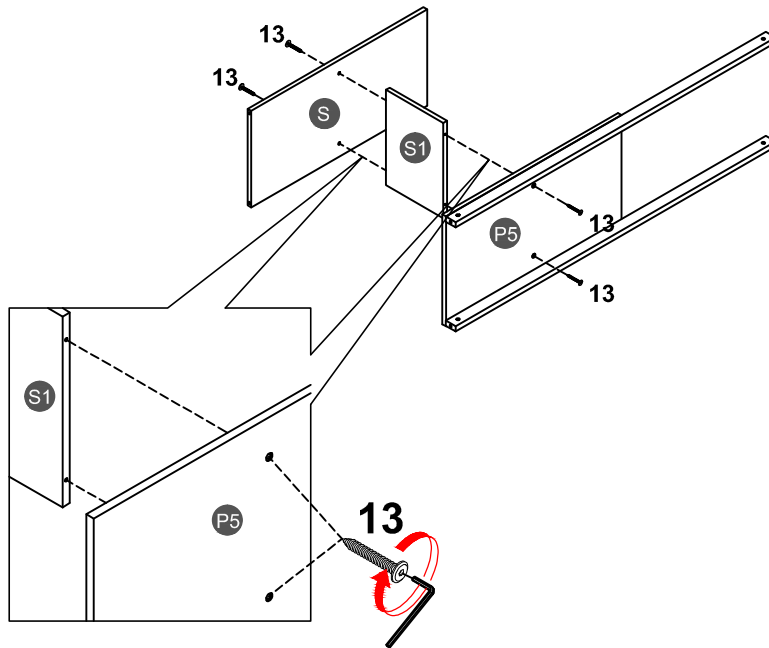

ÉTAPE

13	
4PCS	



STEP 24:

ÉTAPE

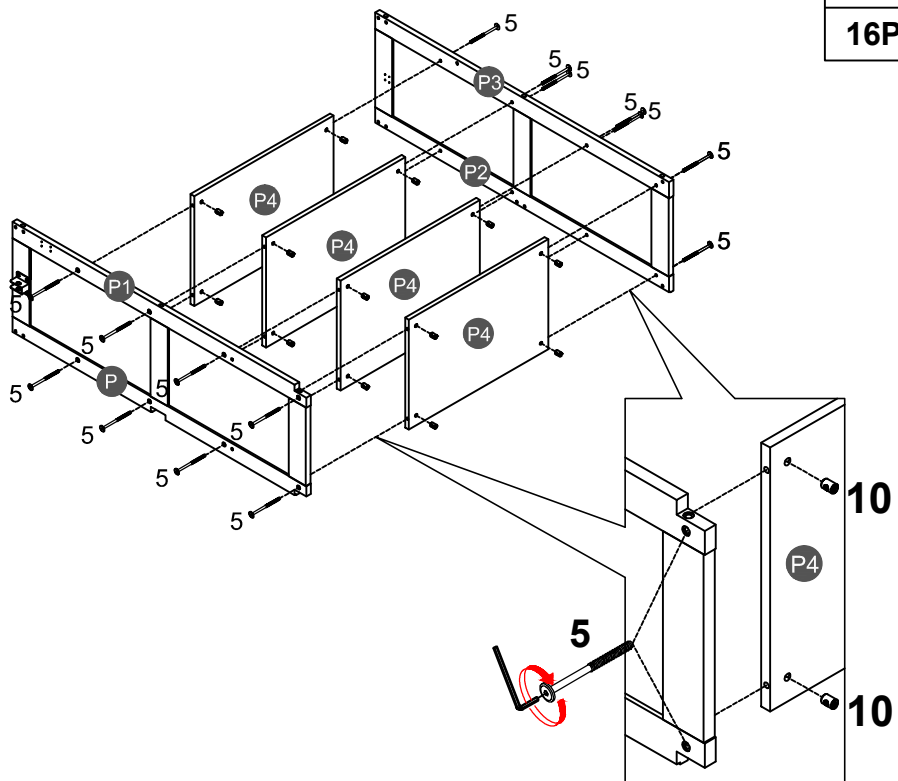

5		10	
16PCS		16PCS	

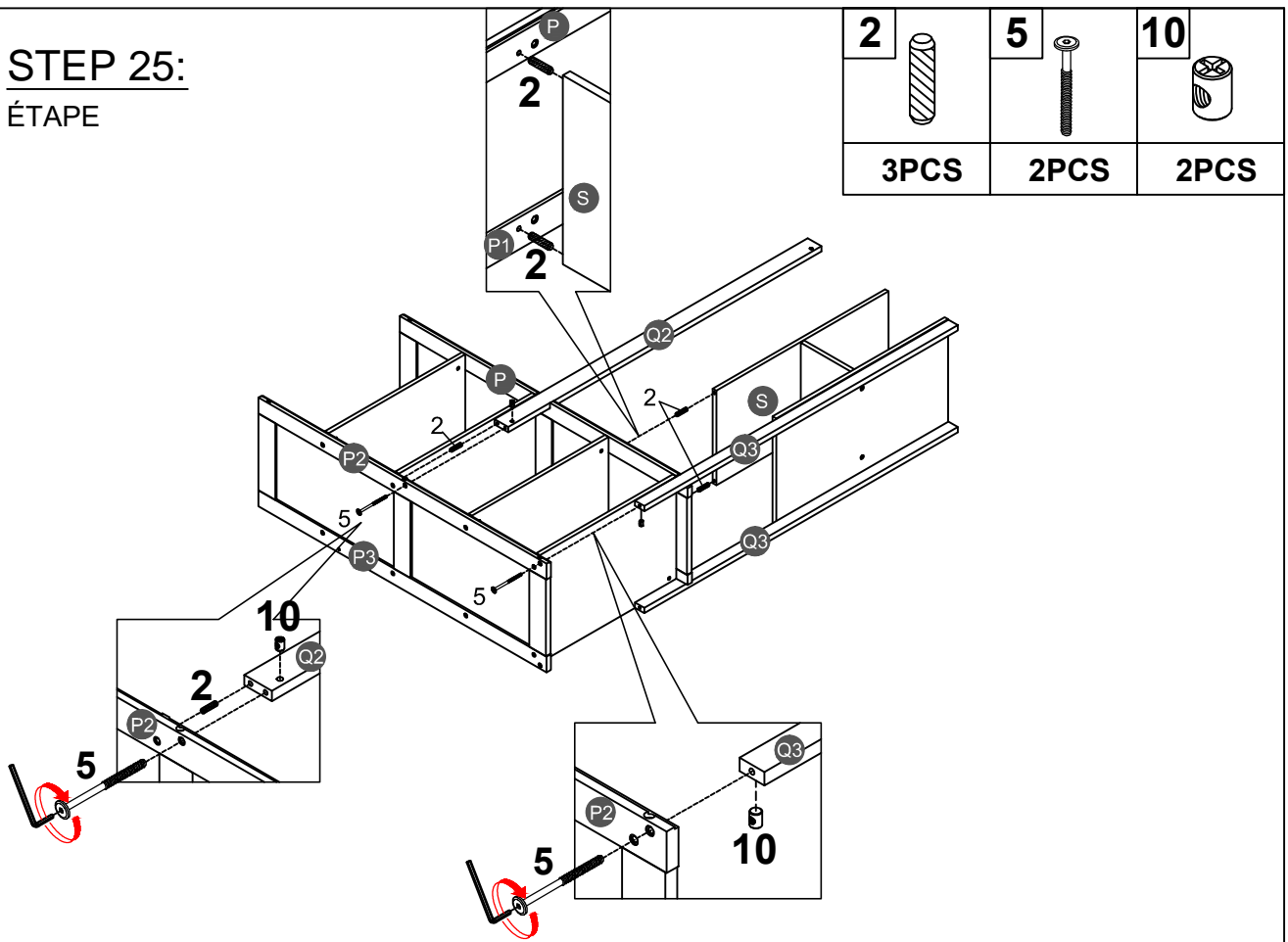

STEP 25:

ÉTAPE





2		5		10	
3PCS		2PCS		2PCS	

STEP 26:

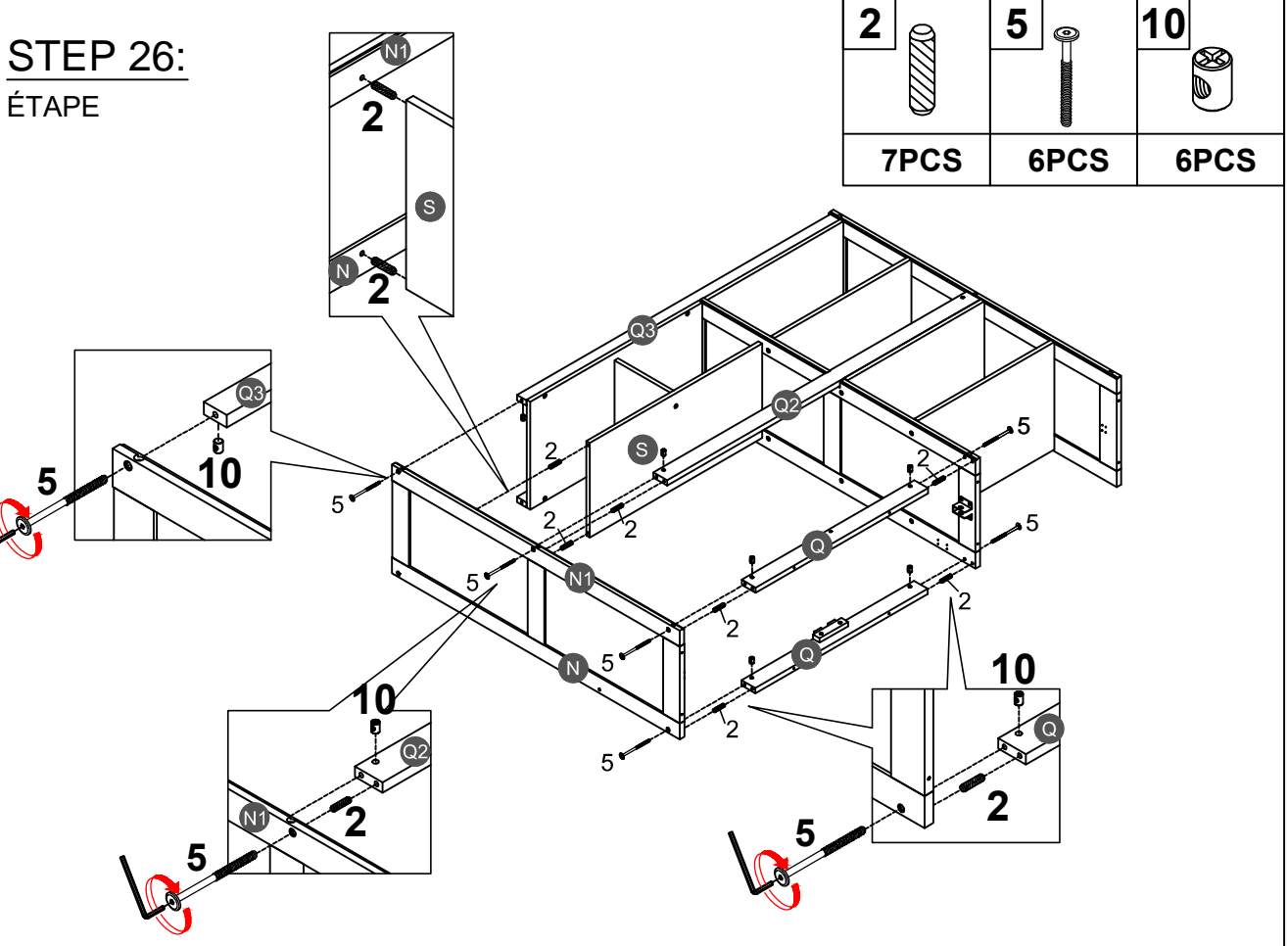
ÉTAPE





2		5		10	
7PCS		6PCS		6PCS	

STEP 27:

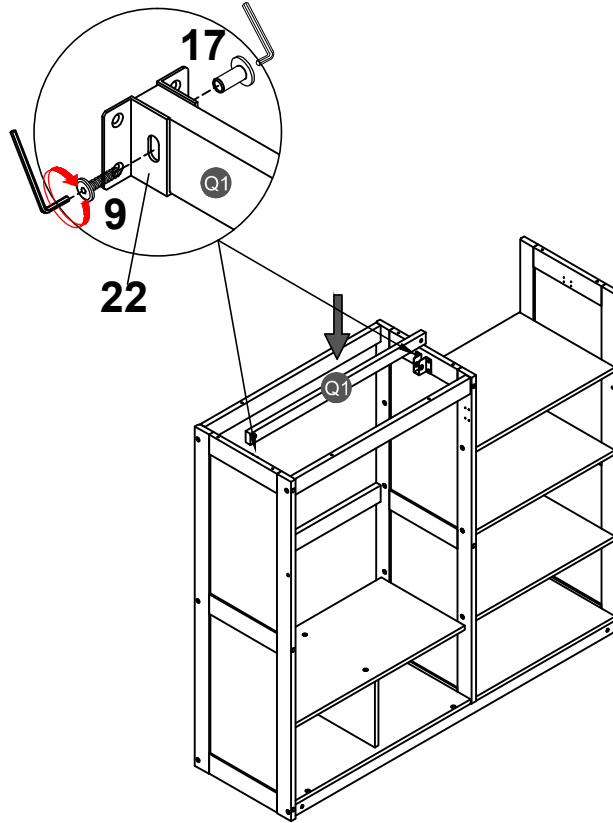
ÉTAPE



9		17	
2PCS		2PCS	

STEP 28:

ÉTAPE

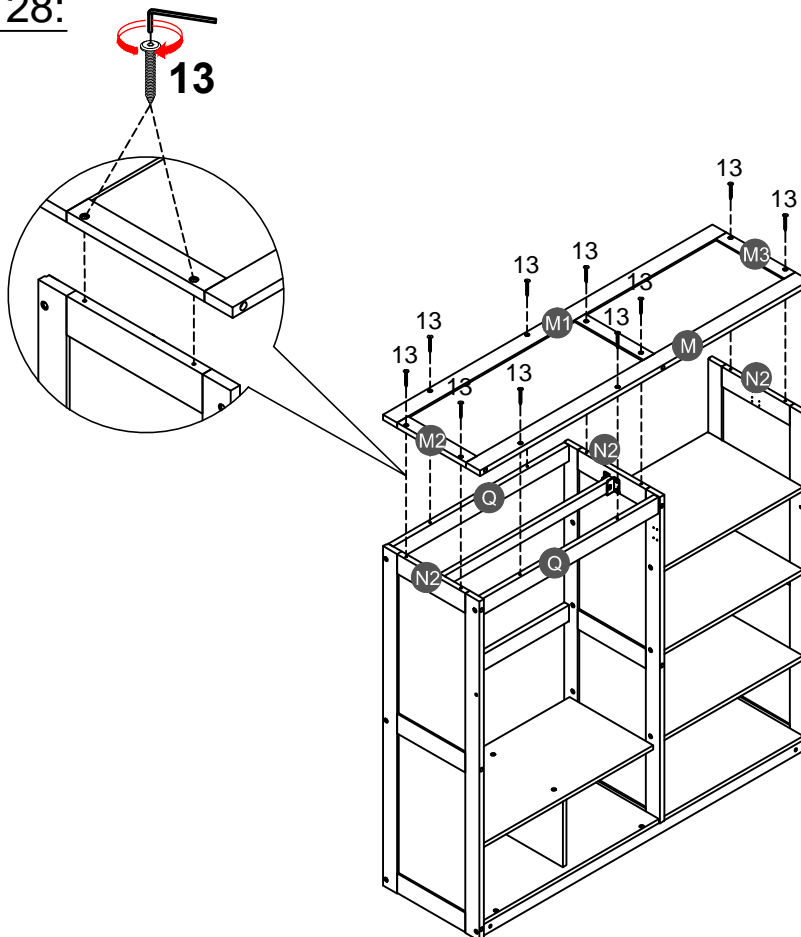



13	
10PCS	

STEP 29:

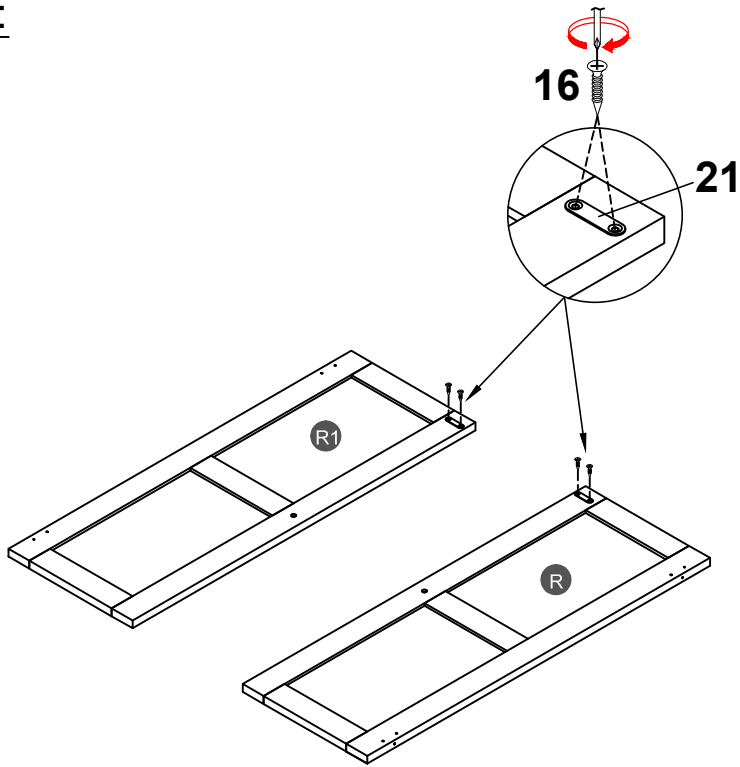
ÉTAPE





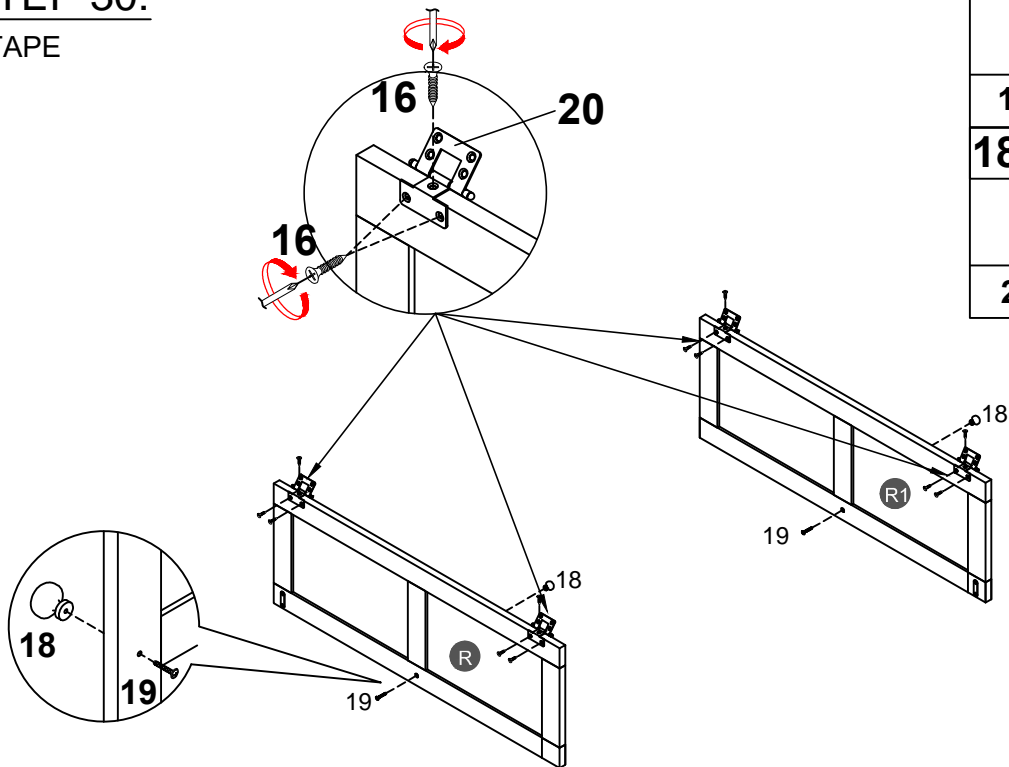

16		21	
4PCS		2PCS	

STEP 30:

ÉTAPE



16		20	
12PCS		4PCS	
18		19	
2PCS		2PCS	

STEP 31:

ÉTAPE

16



16PCS

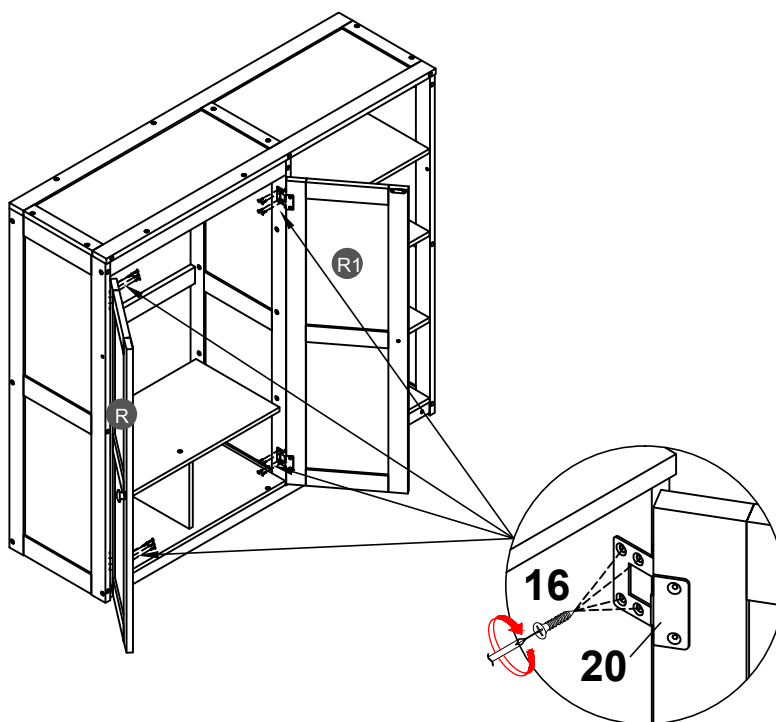

STEP 32:

ÉTAPE

15



12PCS

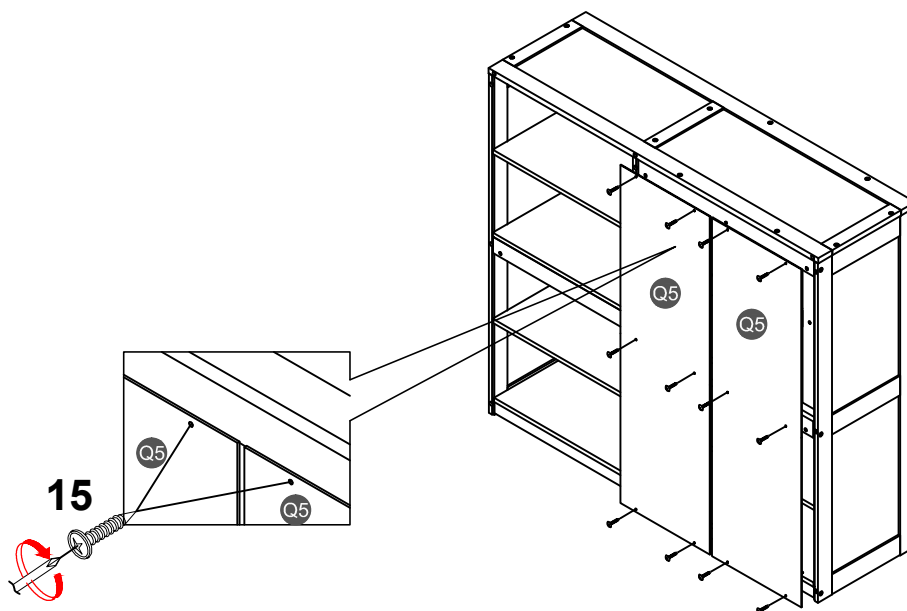

STEP 33:

ÉTAPE

TYPE 1

TAPER

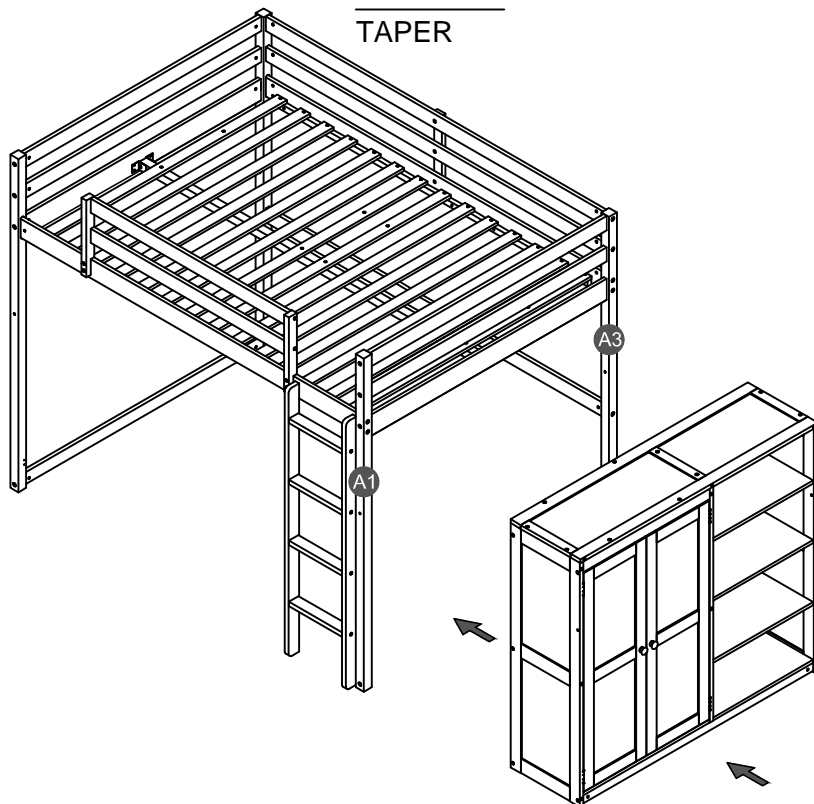

STEP 34:

ÉTAPE

TYPE 1

TAPER

3		5		10	
2PCS		2PCS		2PCS	

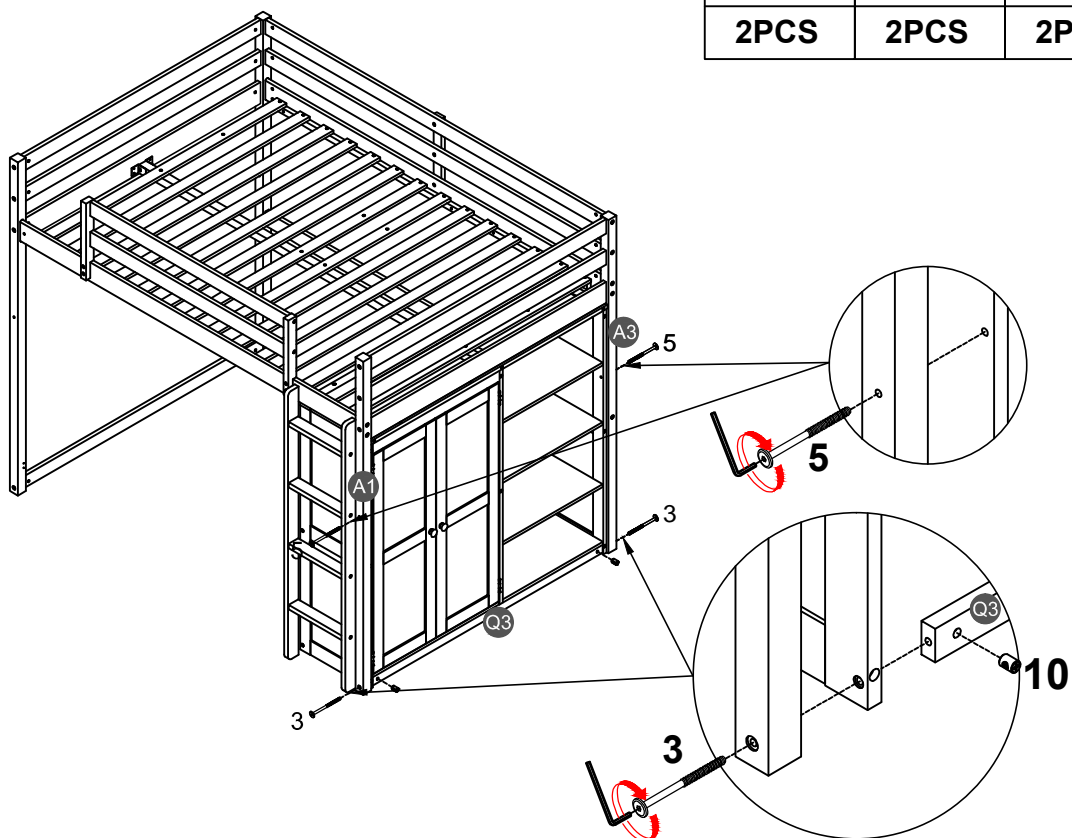

TYPE 1
TAPER

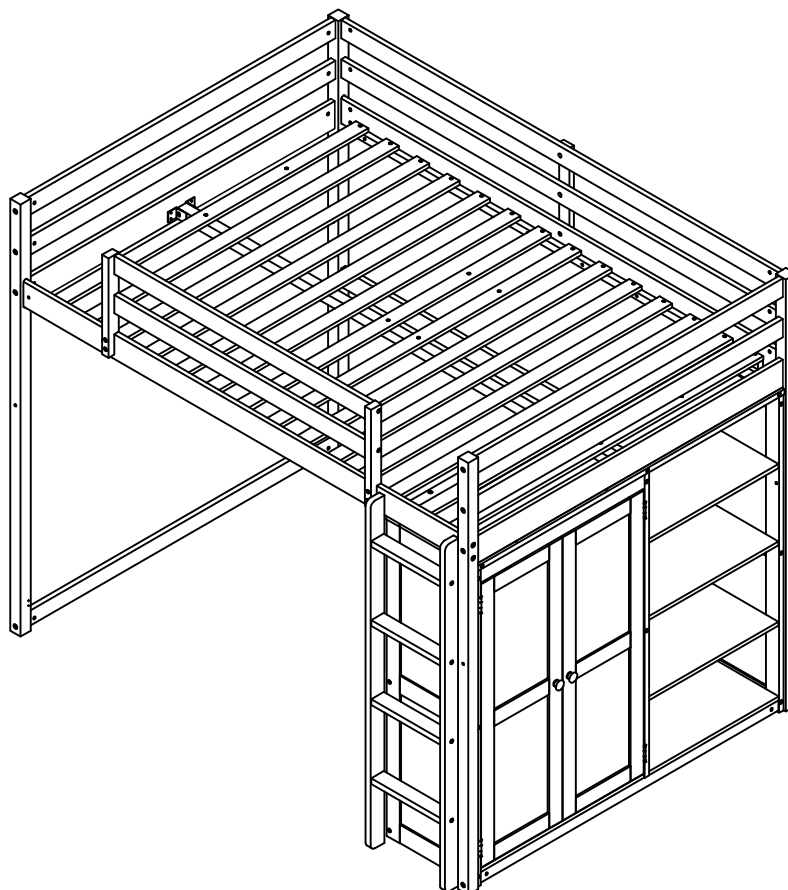

Make sure to tighten all the screws of the bed.

Assurez-vous de serrer toutes les vis des de lit.

STEP 1:
ÉTAPE

TYPE 2
TAPER

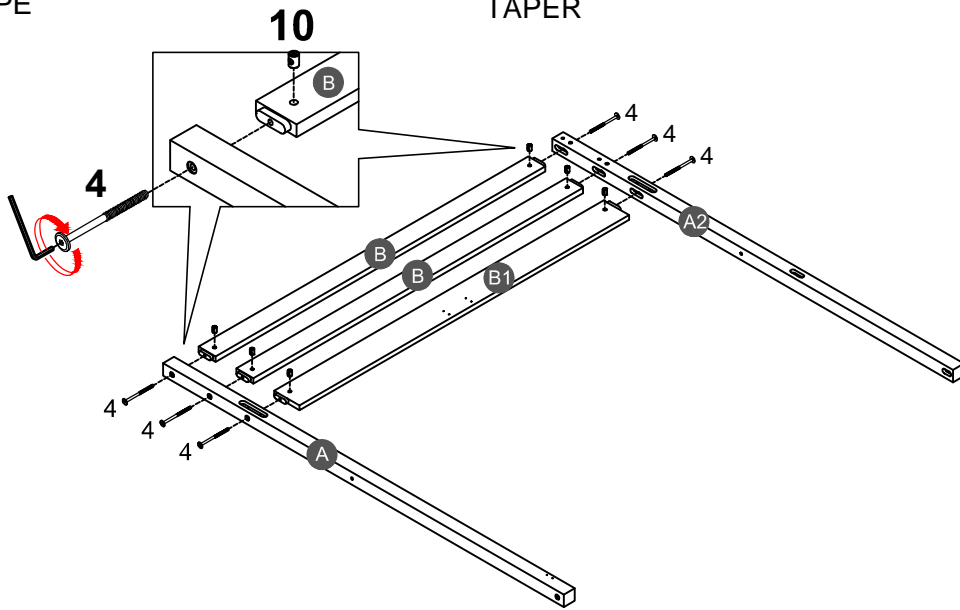

4



6PCS

10



6PCS

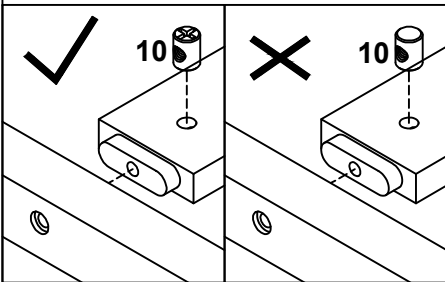

Note: Part 10 will face up with the "x" mark on it, otherwise it cannot be tightened

Remarque: La pièce 10 sera face vers le haut avec la marque "x", sinon elle ne peut pas être serrée.

STEP 2:
ÉTAPE

TYPE 2
TAPER

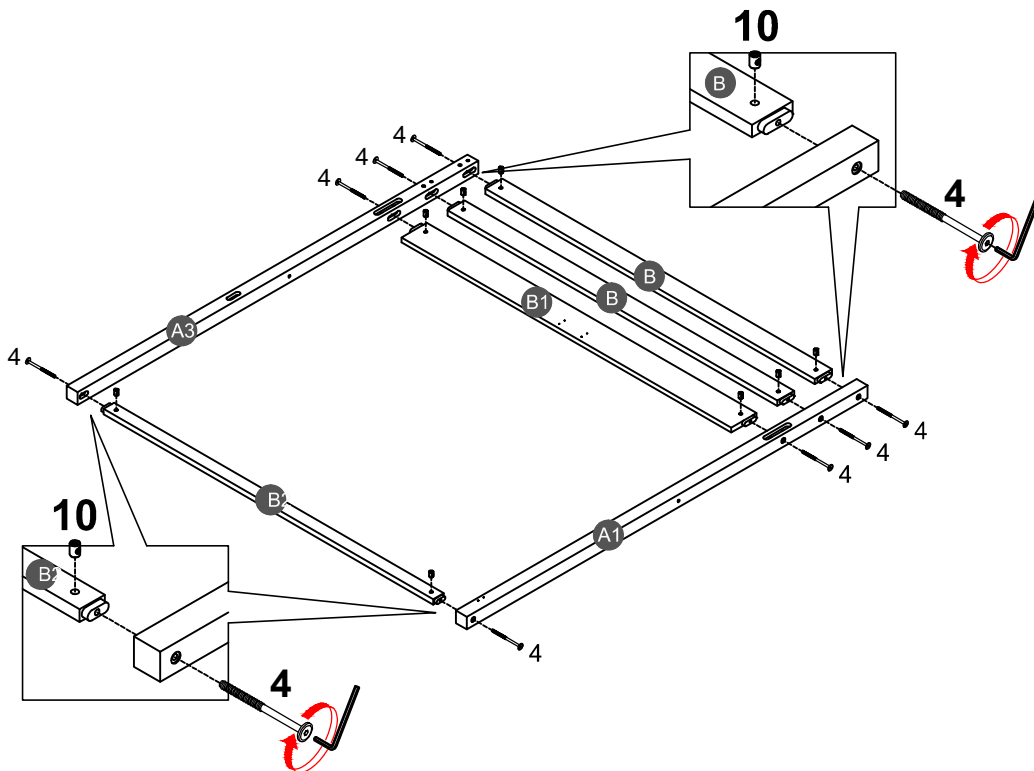

4



8PCS

10





8PCS

STEP 3:
ÉTAPE

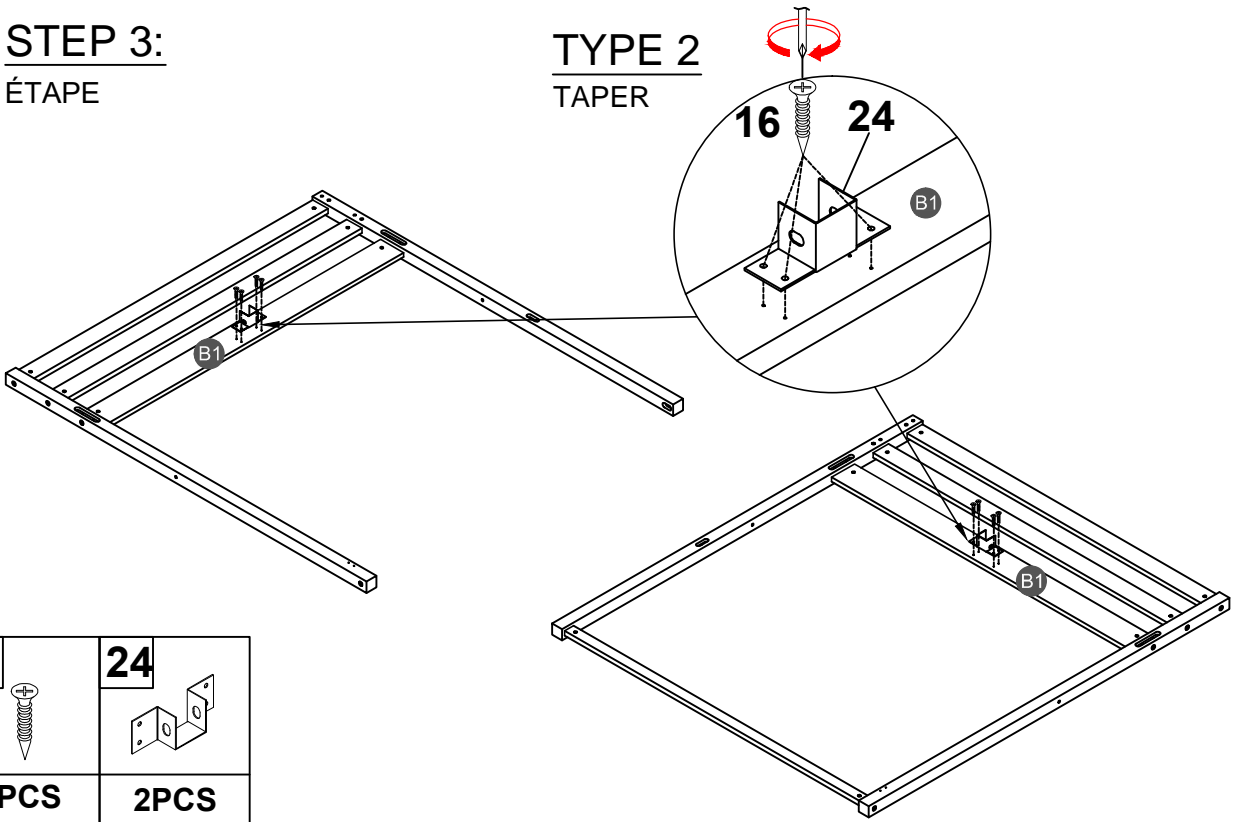
TYPE 2
TAPER





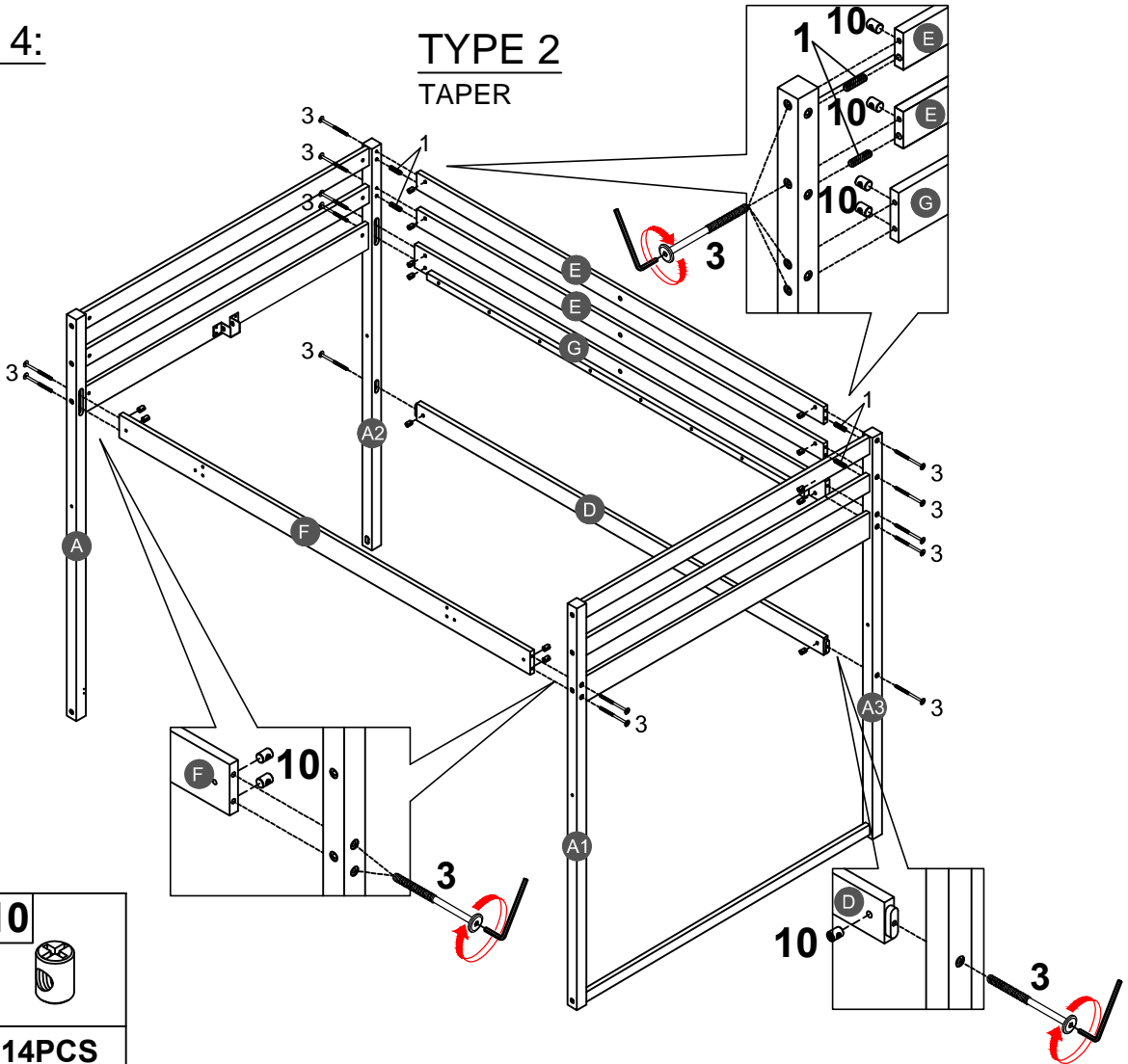

16 	24 
8PCS	2PCS

STEP 4:
ÉTAPE

TYPE 2
TAPER



1 	10 
4PCS	14PCS
3 	10 
14PCS	14PCS

STEP 5:
ÉTAPE

TYPE 2
TAPER

8



3PCS

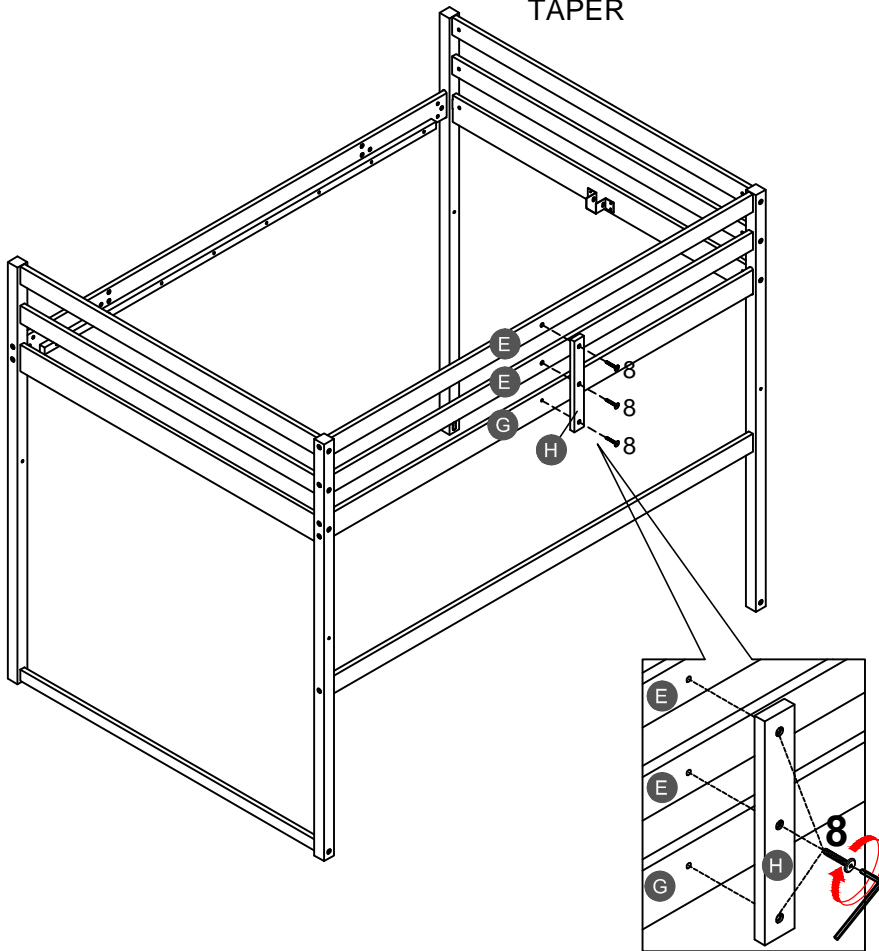

STEP 6:
ÉTAPE

TYPE 2
TAPER

1



4PCS

4

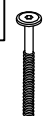

4PCS

10



4PCS

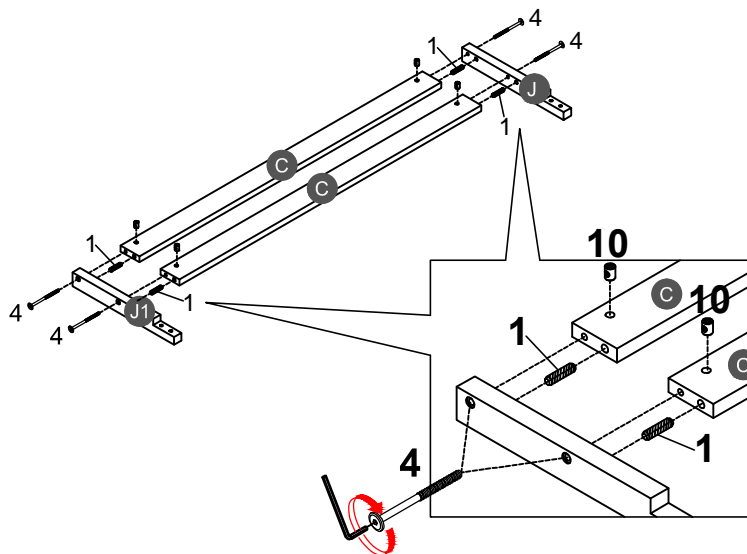

STEP 7:
ÉTAPE

TYPE 2
TAPER

7



4PCS

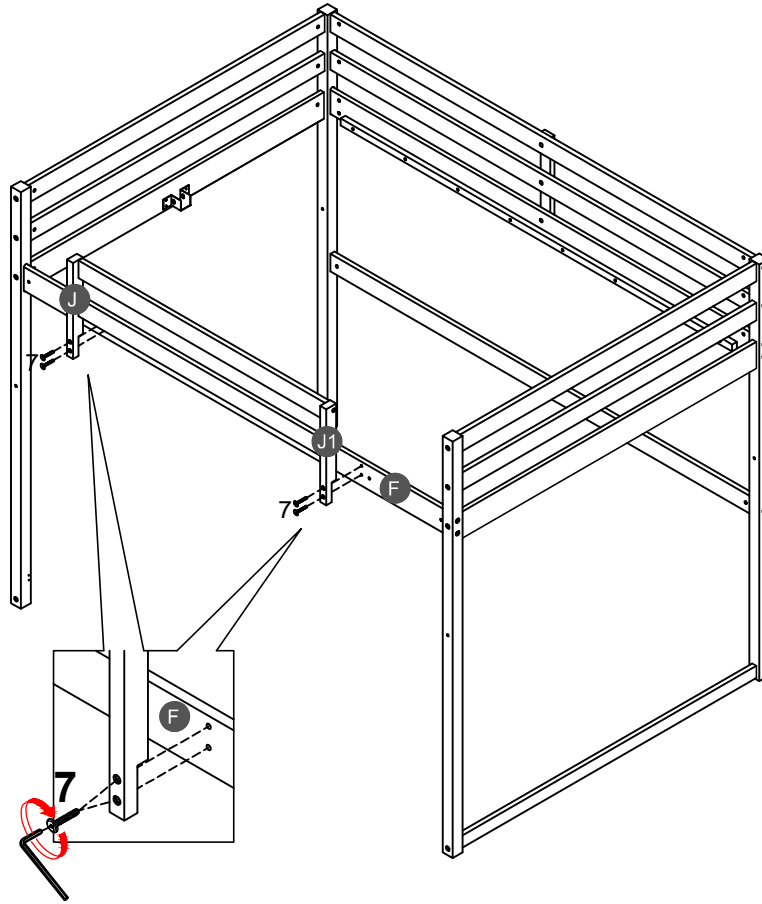

STEP 8:
ÉTAPE

TYPE 2
TAPER

5	10	16	25
8PCS	8PCS	2PCS	1PC

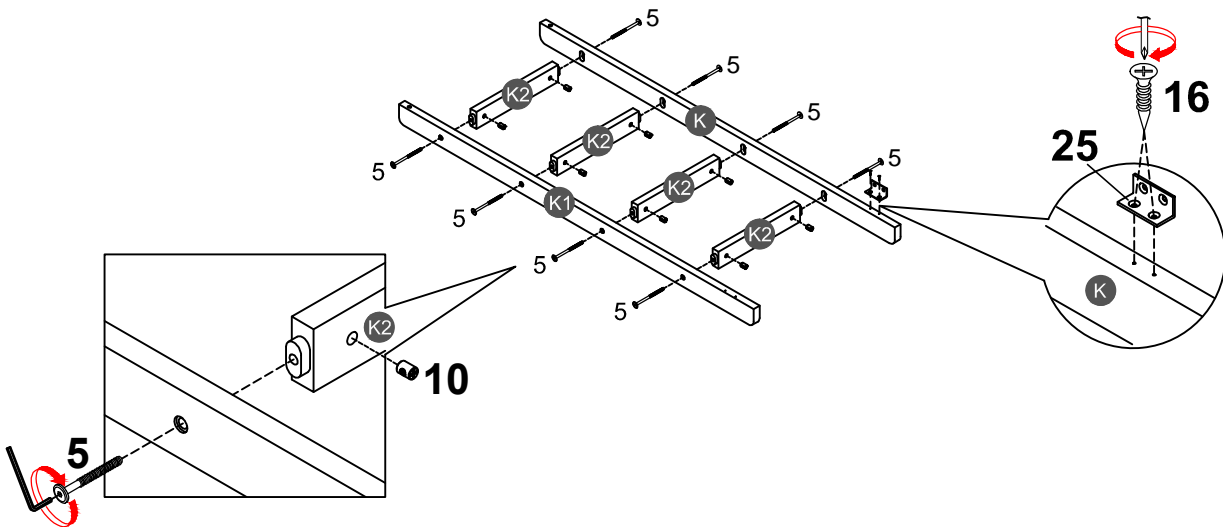

STEP 9:

ÉTAPE

TYPE 2

TAPER

6



2PCS

16



2PCS

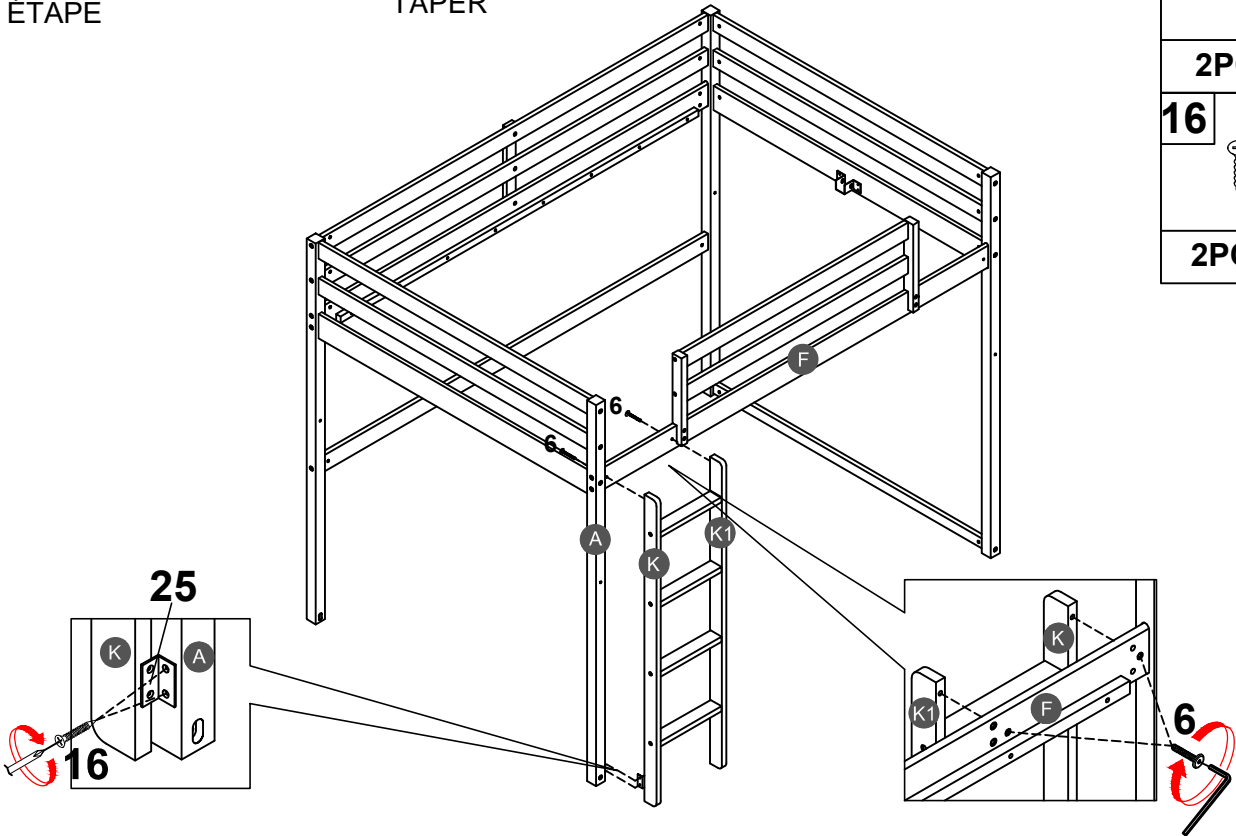

STEP 10:

ÉTAPE

TYPE 2

TAPER

6



2PCS

17



2PCS

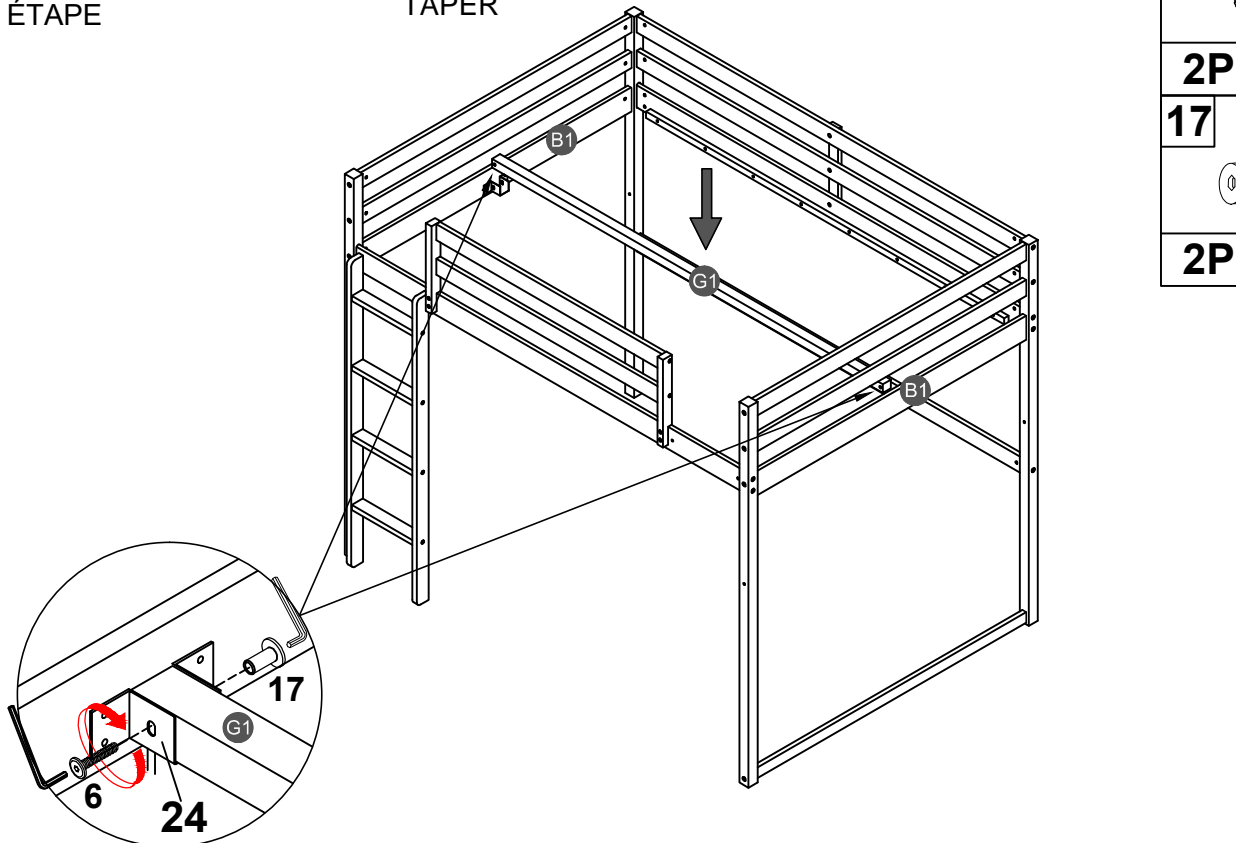



STEP 11:

ÉTAPE

TYPE 2

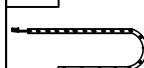
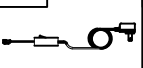
TAPER

16 	26 	27 	28 
1PC	1PC	1PC	1PC

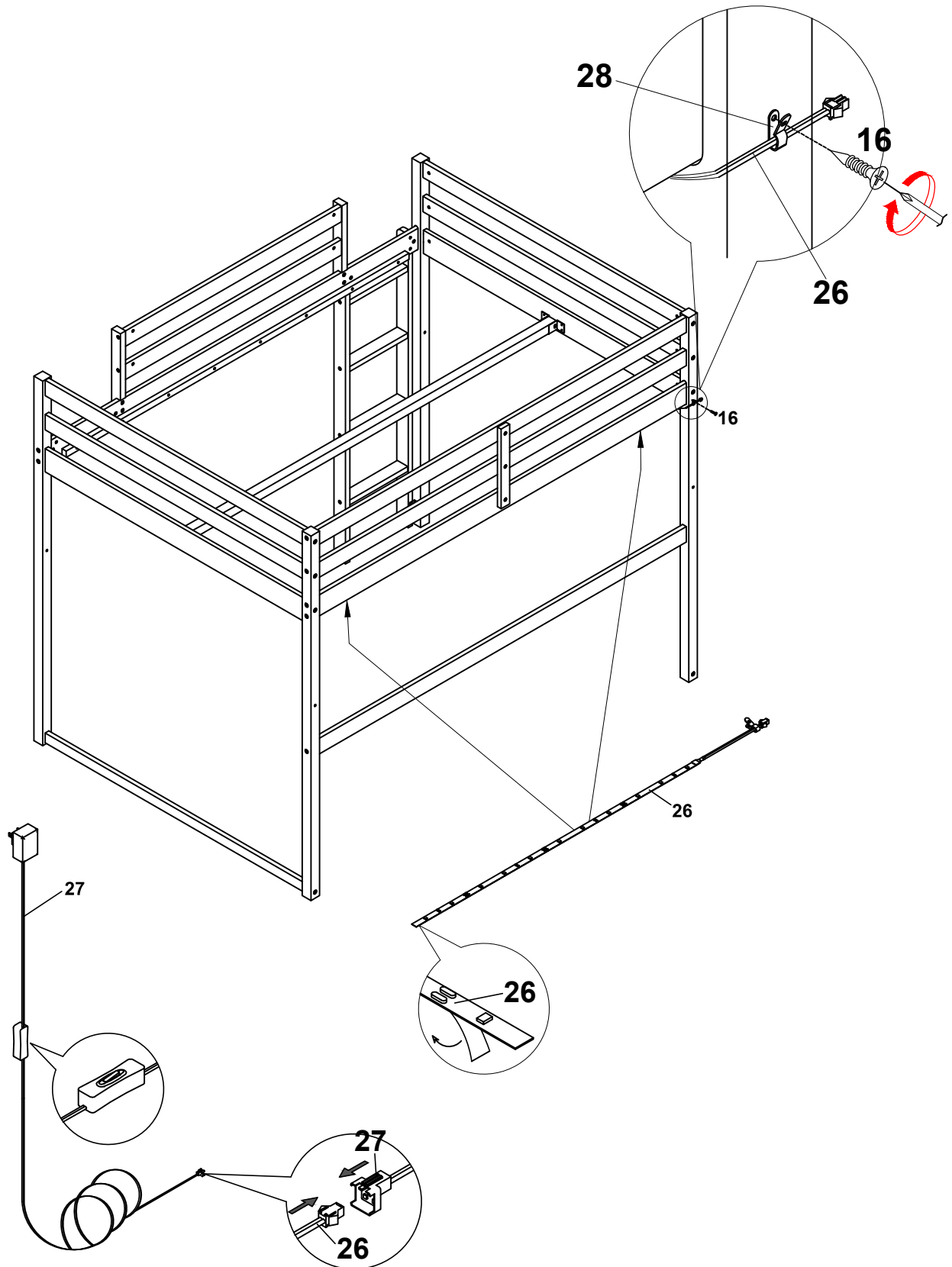

STEP 12:

ÉTAPE

TYPE 2

TAPER

14



32PCS

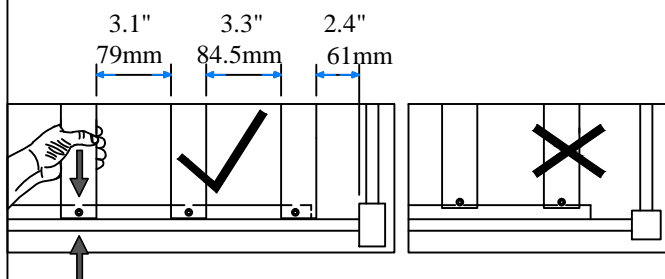
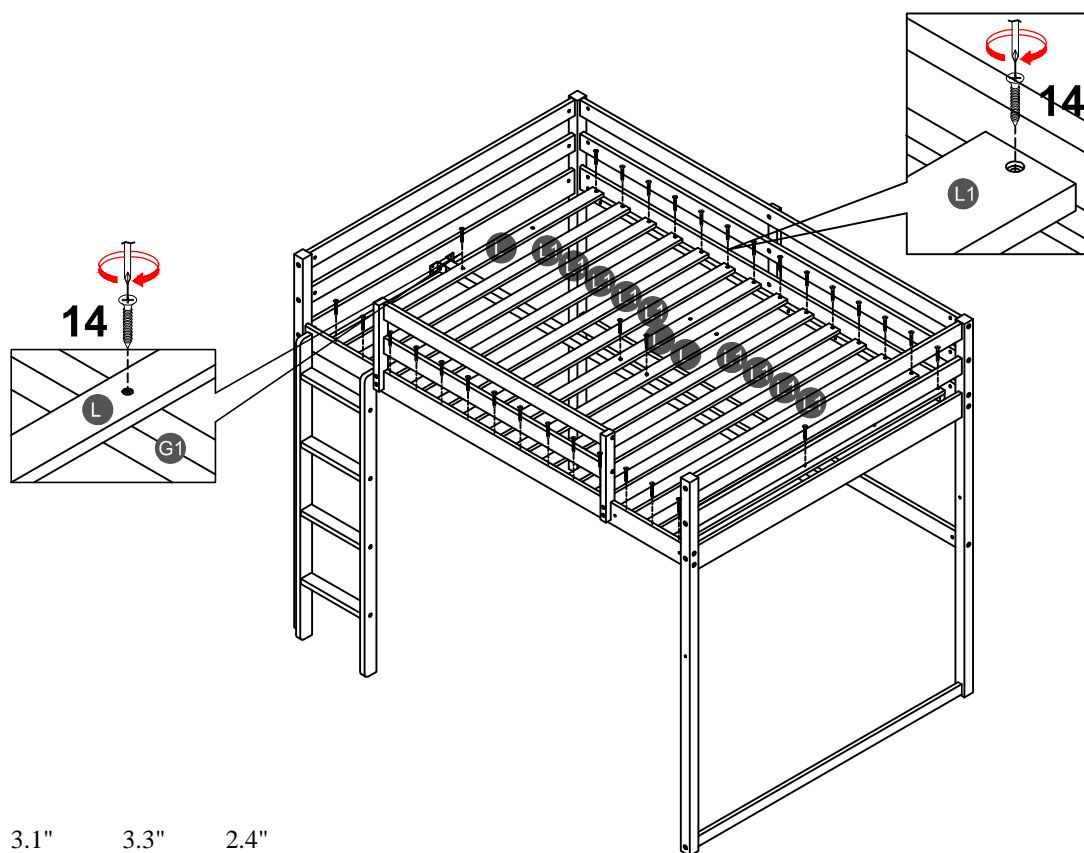

NOTE: Please make sure the bed slats close to the side rail before locking the screws to avoid breakage. This step is required for both the left and right sides. Moreover, please do not lock the screws of the bed slats at the outermost edge to avoid damaging.

Remarque: Assurez-vous Les lattes du lit fermer du rail latéral avant de verrouiller les vis pour éviter la casse. Cette étape est requise pour tous les deux côtés gauche et droit. De plus, ne verrouillez pas les vis des lattes de lit sur le bord le plus extérieur pour éviter d'endommager.

STEP 13:

ÉTAPE

TYPE 2

TAPER

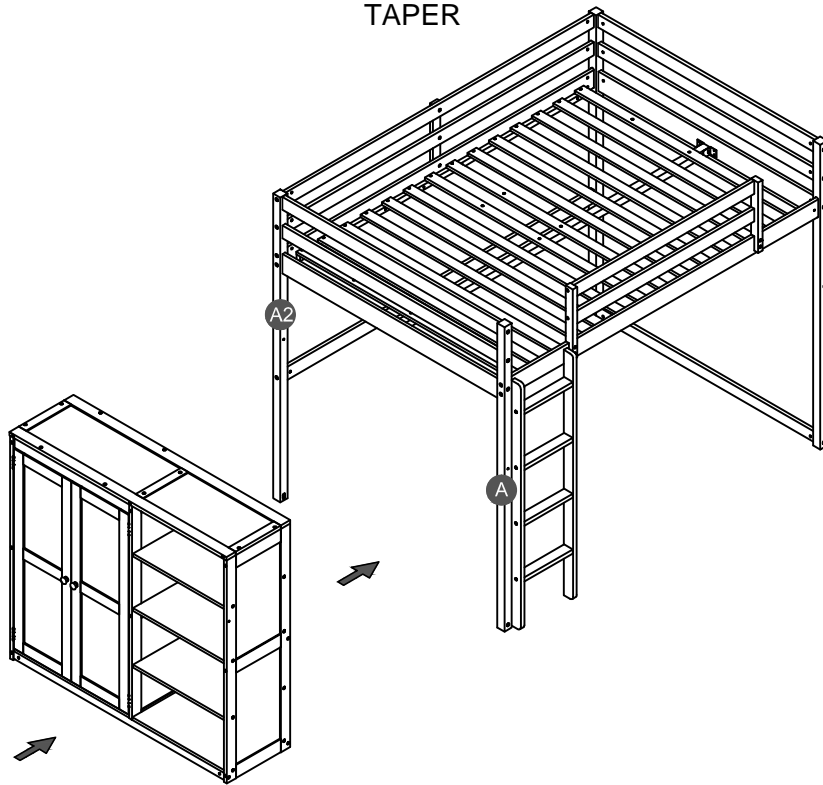

STEP 14:

ÉTAPE

TYPE 2

TAPER

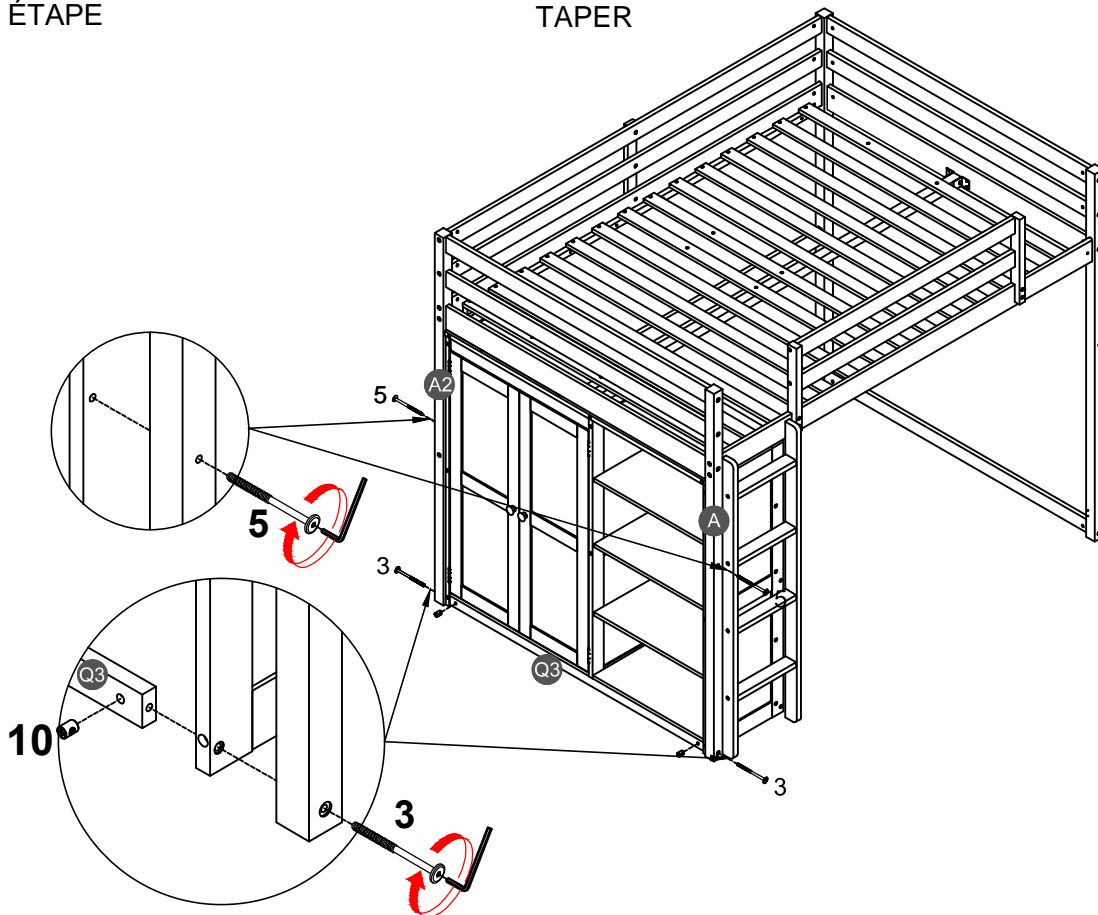

3



2PCS

5



2PCS

10



2PCS

TYPE 2
TAPER

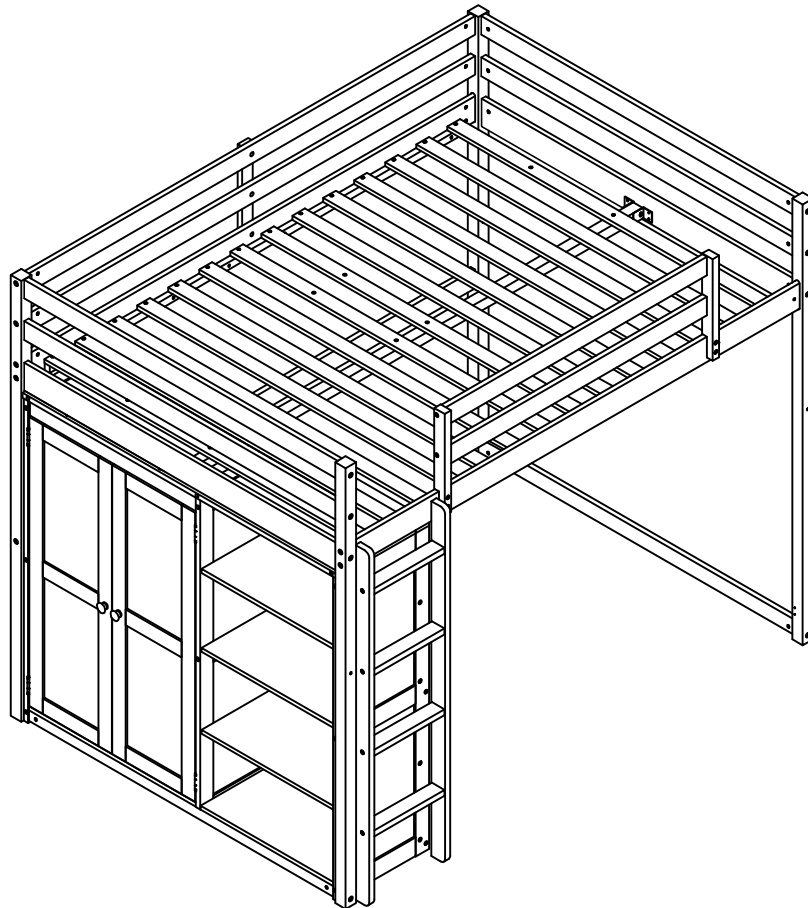

Make sure to tighten all the screws of the bed.

Assurez-vous de serrer toutes les vis des de lit.