

# Assembly Instruction

## Twin House Bed with Trundle Bed

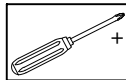

REQUIRED  
ASSEMBLY TOOLS

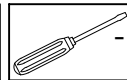

REQUIRED  
ASSEMBLY TOOLS

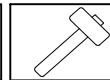

REQUIRED  
ASSEMBLY TOOLS



REQUIRED  
ASSEMBLY TOOLS

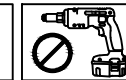

NO POWER  
TOOLS NEEDED



2 PERSON  
ASSEMBLY

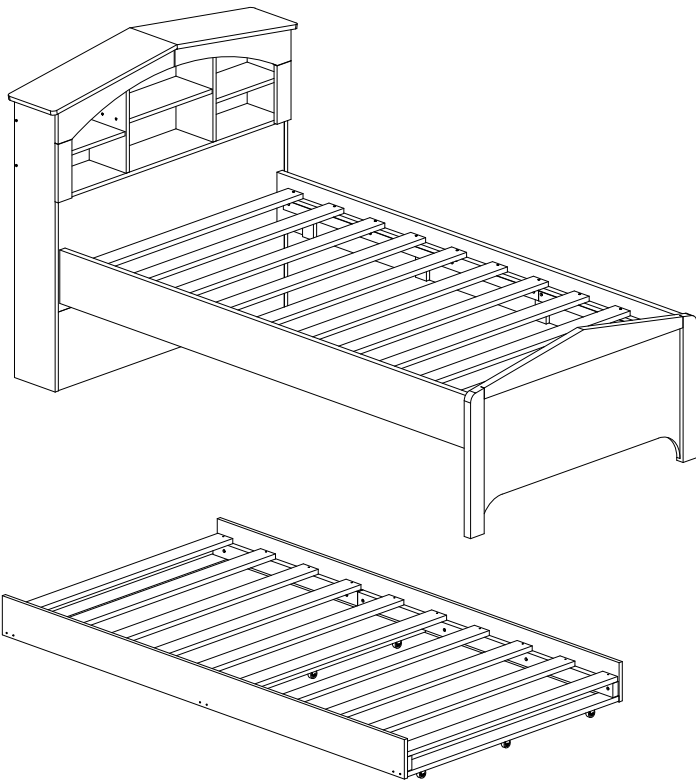

FRONT VIEW

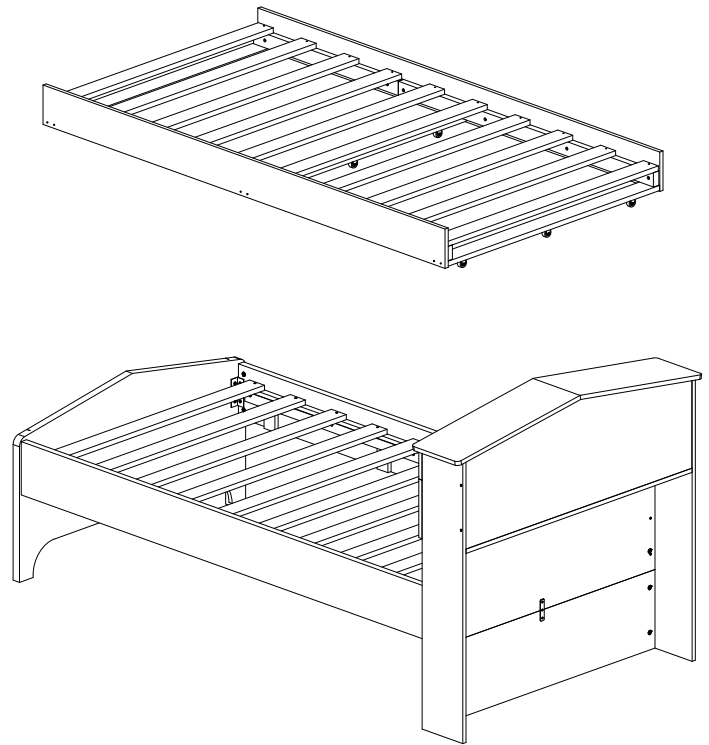

BACK VIEW

**Product Dimensions: Height 43.11" x Width 45.39" x Depth 84.13"**

**WF317091 / WF317092**

# Assembly Instruction

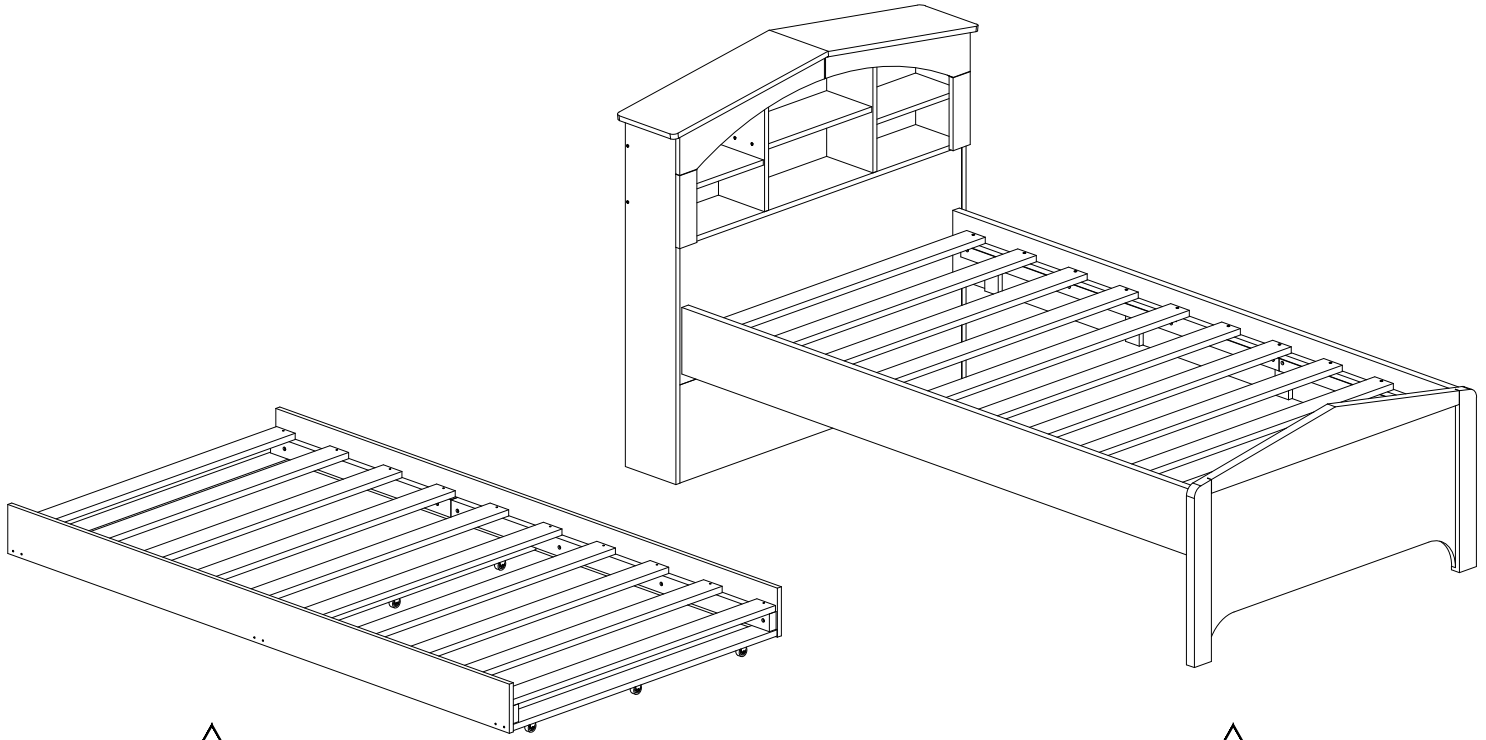

## **SAFETY WARNINGS**











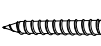
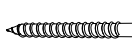

1. This bed is designed for use only mattress(es) meeting the following specifications on the main bed, and trundle:

<b>Bed Type</b>	<b>Length</b>	<b>Width</b>	<b>Thickness</b>
Main Bed	75"	39"	8" max
Trundle	75"	39"	7.6" max

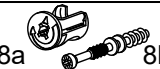
2. Replacement parts, may be obtained from any of our (COMPTREE. INC) dealers
3. Always use the recommended size mattresses or mattress supports, or both, to help prevent the likelihood of entrapment or falls.
4. Do not allow horseplay on or under the bed and prohibit jumping on the bed.
5. Do not use substitute parts. Contact the manufacturer or dealer for replacement parts.
6. The use of water or sleep flotation mattresses is prohibited.
7. **STRANGULATION HAZARD** - Never attach or hang items to any part of the bed that are not designed for use with the bed; for example, but not limited to, hook, belts and jump ropes.
8. Keep these instructions for future reference

# Assembly Instruction

## Hardware List - WF317091

<i>Hardware List</i>			
<i>No.</i>	<i>SHAPE</i>	<i>DESCRIPTION</i>	<i>Qty.</i>
1		<b>6x25mm PVC Dowel</b>	38Pcs
2		<b>M3.5x14mm Screw</b>	20Pcs
3		<b>M4x32mm Screw</b>	40Pcs
4		<b>M6x40mm Screw</b>	25Pcs
5		<b>M6x70mm Screw</b>	4Pcs
6		<b>TP 10#x1/2" Screw</b>	12Pcs
7		<b>15MM Screw Cap</b>	29Pcs
8		<b>15MM Myfix Minifix</b>	30Sets
9		<b>17 MM MiniFix Cap</b>	30Pcs
10		<b>Shelf Support</b>	8Pcs
11		<b>L-Bracket (100mmx30mm) (Black)</b>	2Pcs
12		<b>Straight Bracket</b>	1Pc
13		<b>M4 Allen Key</b>	1Pc
14		<b>Rigid Caster(Ø29,H39mm)</b>	9Pcs

# Assembly Instruction

## Parts List - WF317091

**B** Head Board Front Panel-Up  
1063x393x15mm  
2Pcs

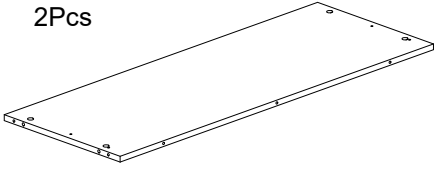

**D** Head Board Stand Panel L  
360x174x15mm  
1Pc

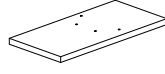

**F** Head Board Stand Panel R  
360x174x15mm  
1Pc

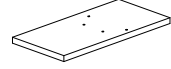

**I** Side Panel L  
1910x190x25mm  
1Pc

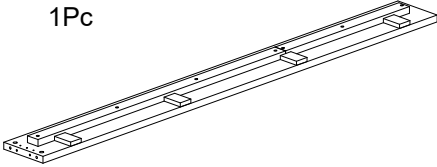

**K** Side Panel R  
1910x190x25mm  
1Pc

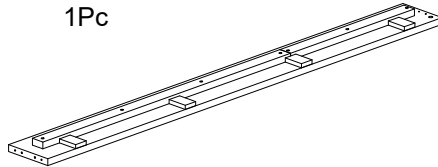

**L2** Head Board Pillar L  
208x65x15mm  
1Pc

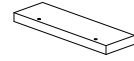

**L3** Head Board Pillar R  
208x65x15mm  
1Pc

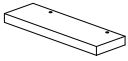

**M** Adjust Panel  
319x170x15mm  
2Pcs

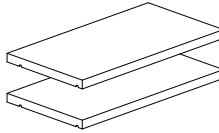

**Q** Trundle Bed Side Panel  
1890x140x15mm  
2Pcs

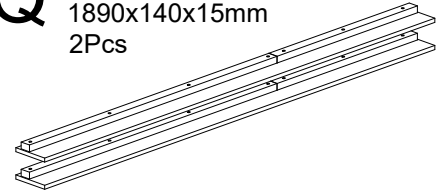

# Assembly Instruction

## Parts List - WF317092

**A** Head Board Side Panel-L  
1000x191x15mm  
1Pc

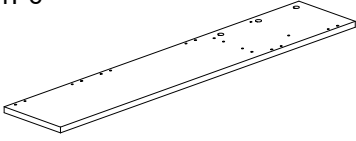

**B1** Head Board Front Panel-Down  
1063x280x15mm  
1Pc

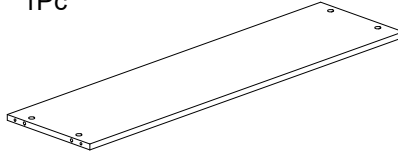

**C** Head Board Partition Panel B  
1063x190x15mm  
1Pc

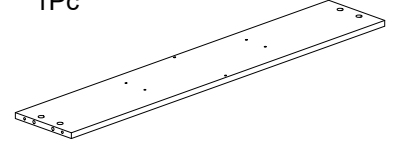

**E** Head Board Partition S  
393x170x15mm  
1Pc

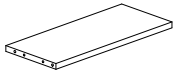

**G** Head Board Back Panel  
1063x391x15mm  
1Pc

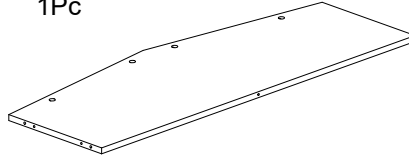

**H** Head Board Side Panel-R  
1000x191x15mm  
1Pc

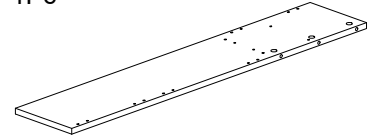

**J** Foot Board Panel  
1063x600x30mm  
1Pc

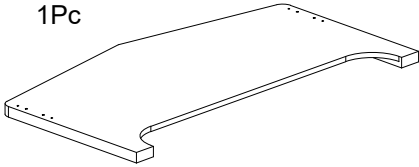

**L** Head Board Front Pillar L  
1095x192x15mm  
1Pc

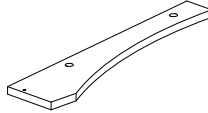

**L1** Head Board Front Pillar L  
1095x192x15mm  
1Pc

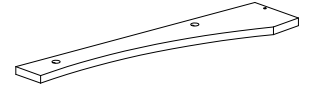

**N** Roof Panel B  
586x222x15mm  
1Pc

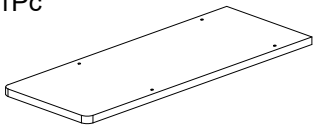

**O** Drawer Panel B  
581x222x15mm  
1Pc

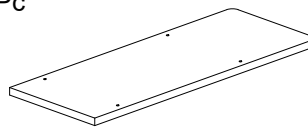

**P** Bed Slat  
991x70x18mm  
20Pcs

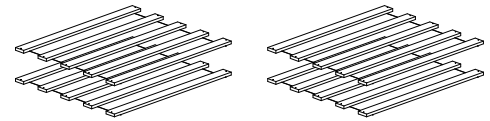

**R** Trundle Bed Support  
995x70x18mm  
3Pcs

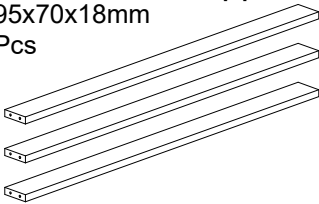

# Assembly Instruction

## The Breakdown

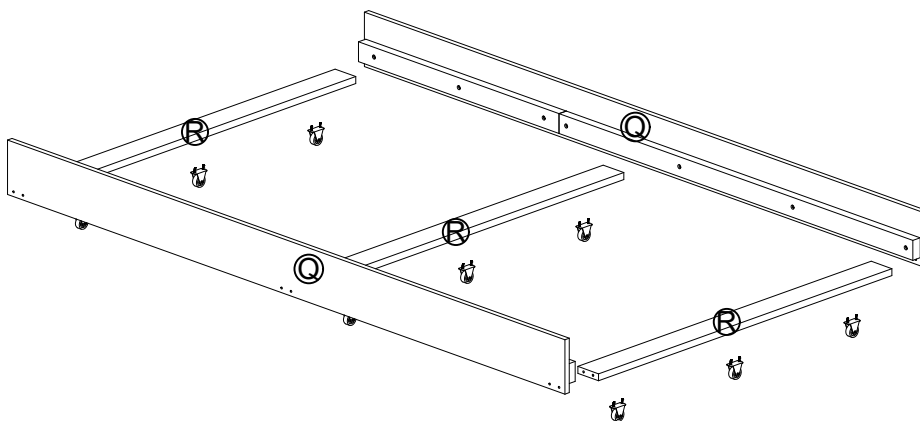
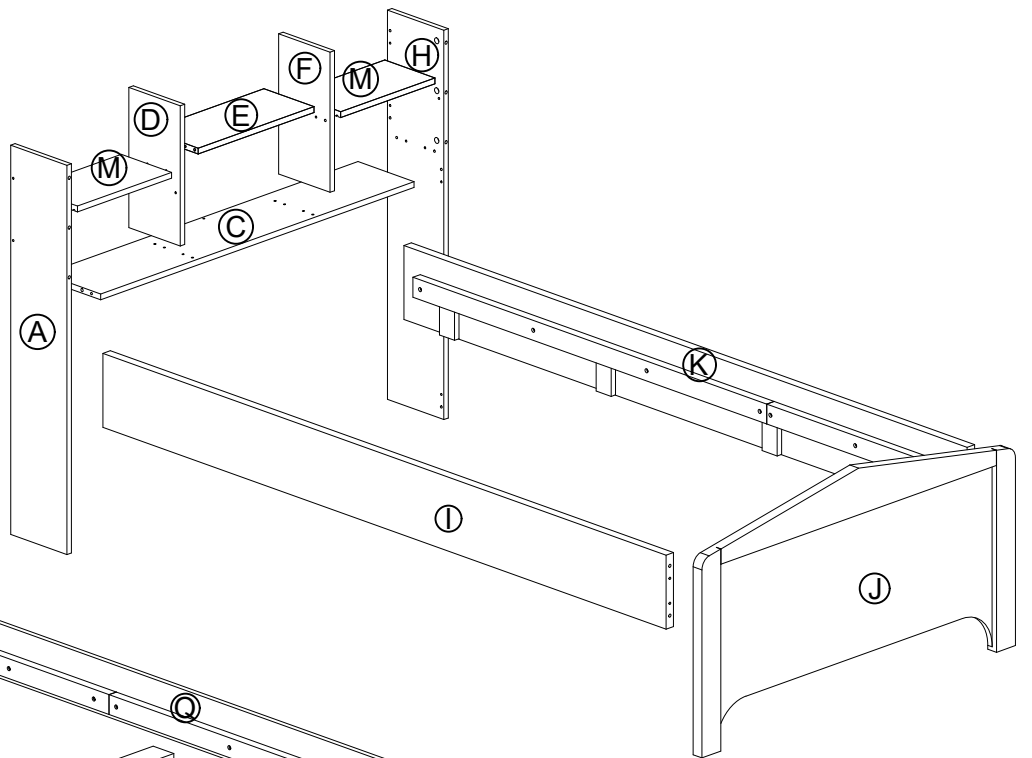
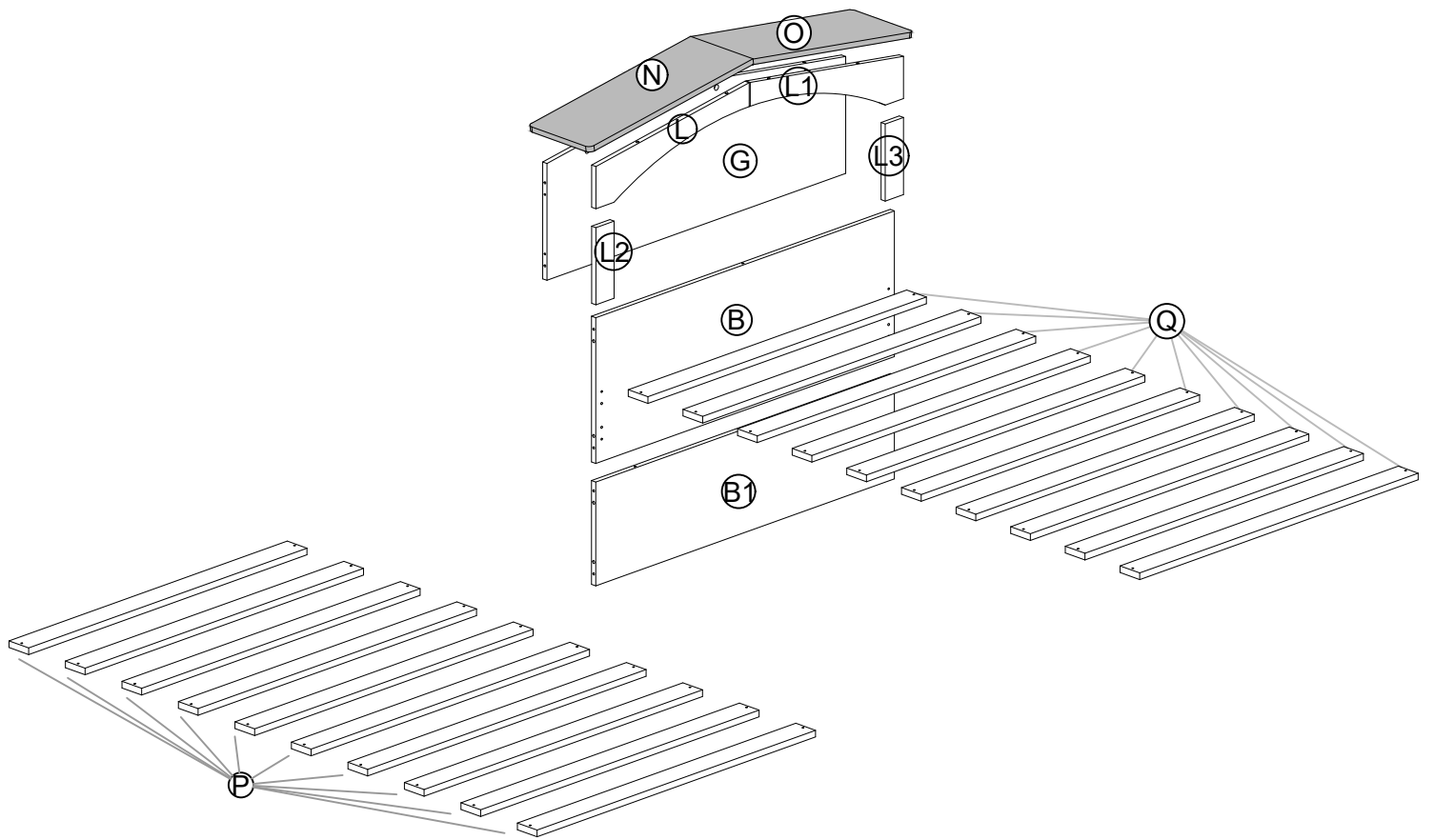

# Assembly Instruction

## Step 1

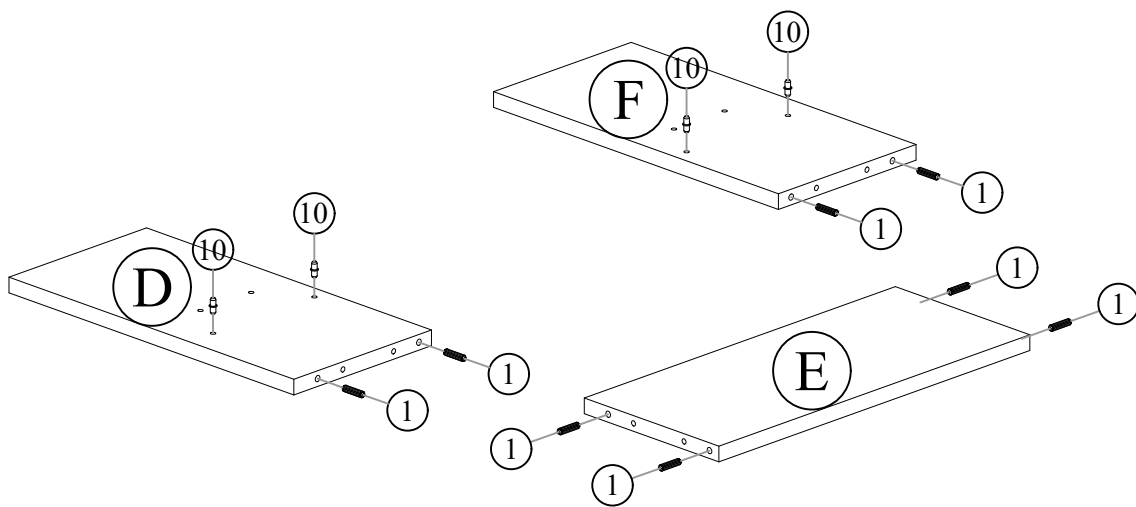

- Install the 6x25mm pvc dowel (1) into Panel (D), (E), and (F) as shown in the diagram.
- Attach the shelf support (10) to Panel (D) and (F) as indicated in the diagram.

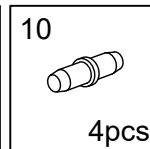
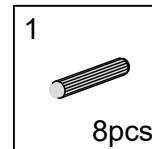

## Step 2

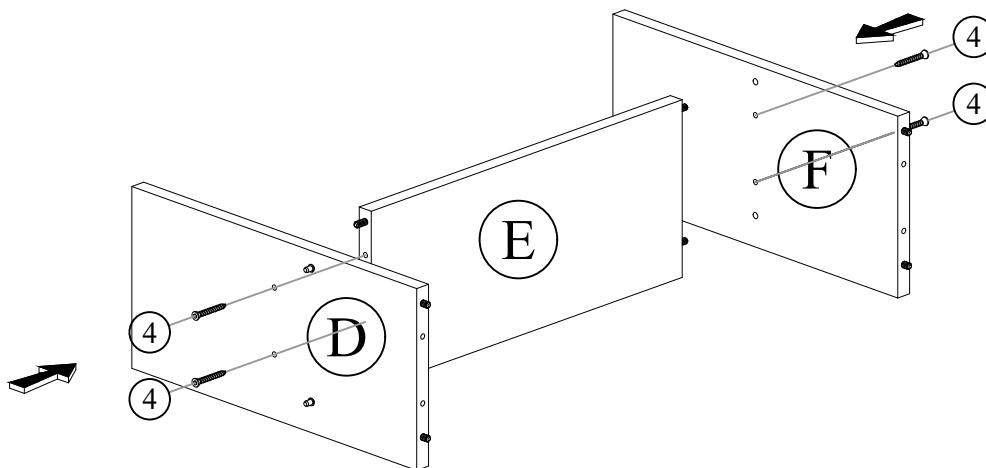

- Start by assembling Panels (D), (E), and (F) as shown in the diagram.
- Use the Allen Key (13) to tighten the M6X40MM Screws (4) securely.

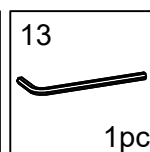
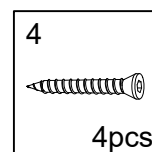

# Assembly Instruction

## Step 3

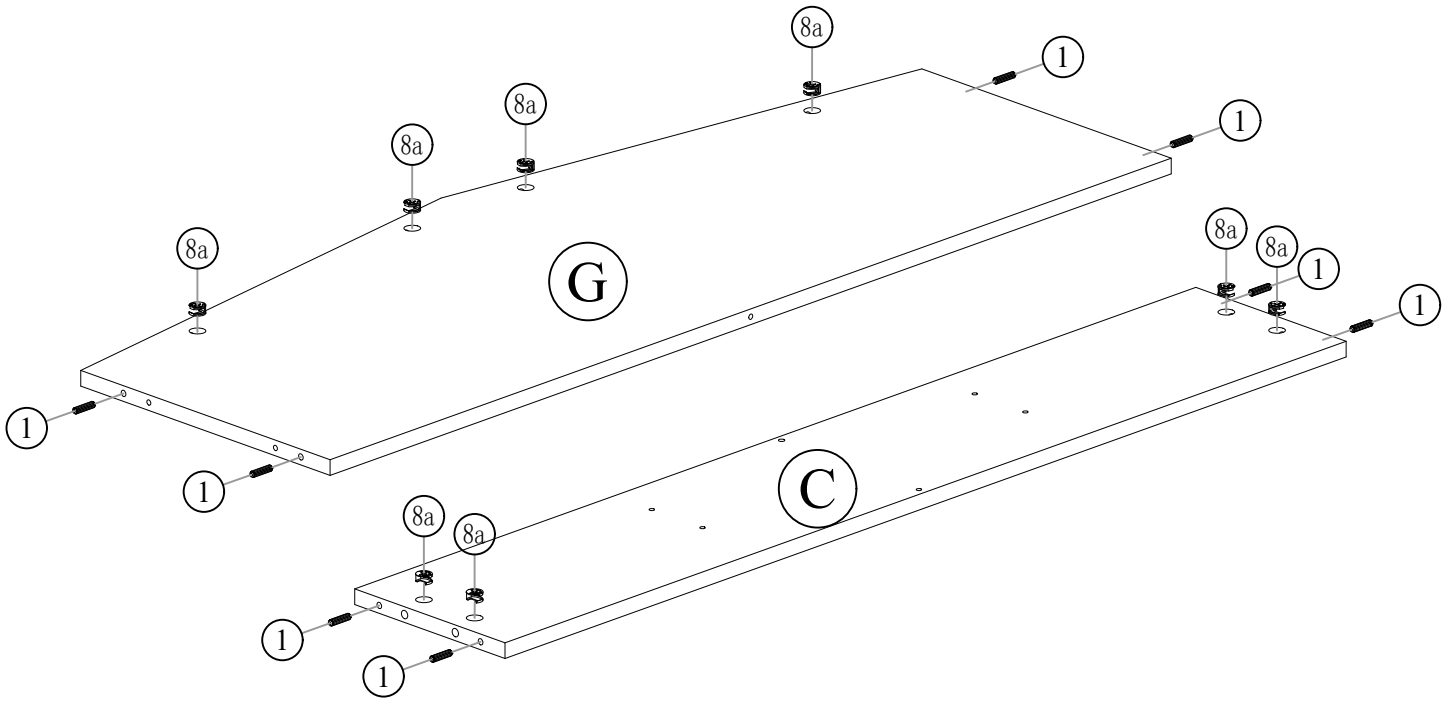

- Install the 6x25mm pvc dowel (1) into Panel (G) and (C) as shown in the diagram.
- Attach the mini fix nuts (8a) to Panel (G) and (C) as indicated in the diagram.

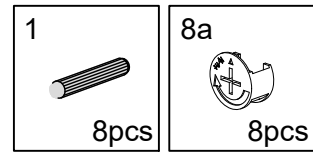

## Step 4

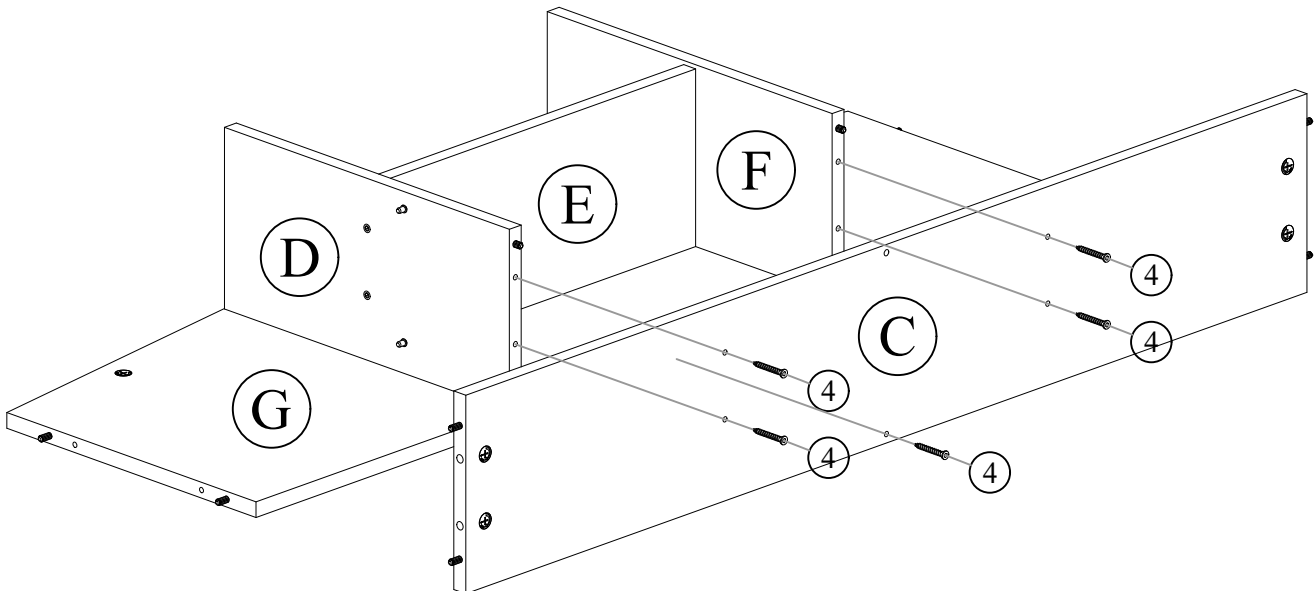

- Put Panels (D), (E) and (F) on Panel (G) and assemble with Panel (C).
- Use the Allen Key (13) to tighten the M6X40MM Screws (4) securely.

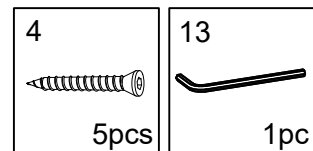
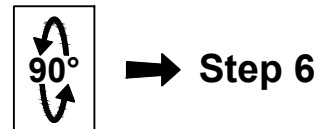



# Assembly Instruction

## Step 5

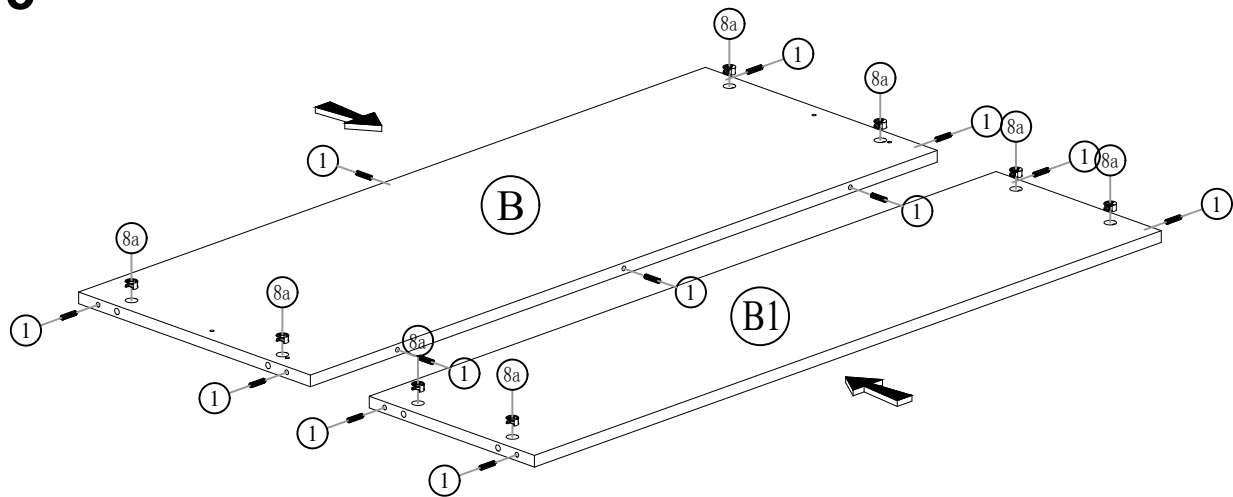

- Install the 6x25mm pvc dowel (1) into Panel (B) and (B1) as shown in the diagram.
- Attach the mini fix nuts (8a) to Panel (B) and (B1) as indicated in the diagram.
- Then connect Panel (B) and (B1) .

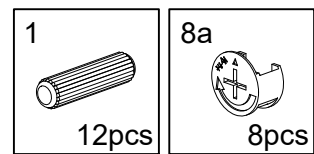

## Step 6

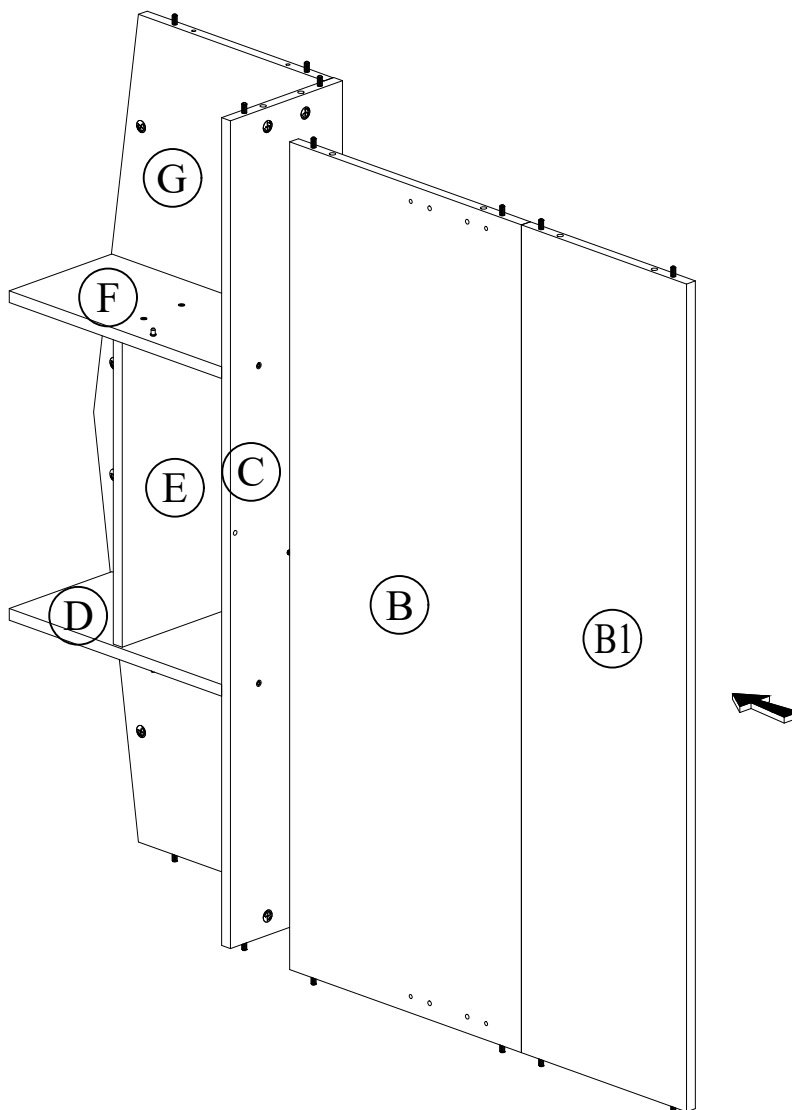

- Start assembling Panels (B) and (C) as shown in the diagram.

# Assembly Instruction

## Step 7

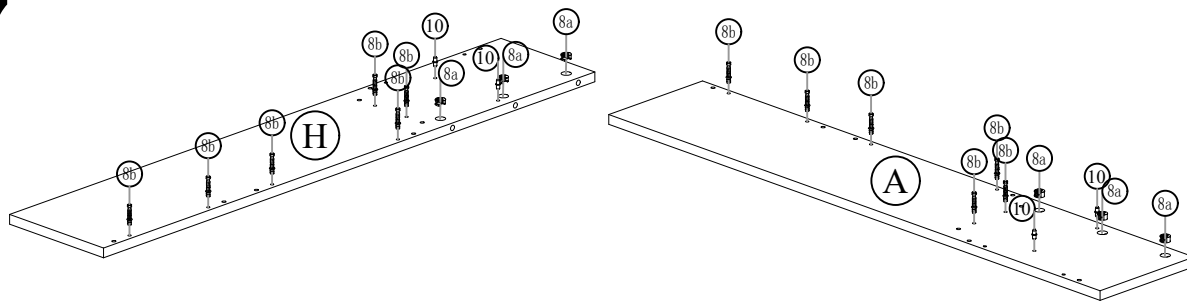

- Attach the shelf support ⑩ to Panel ① and ② as indicated in the diagram.
- Attach the mini fix nuts ⑧a to Panel ① and ② as indicated in the diagram.
- Attach the mini fix screws ⑧b to Panel ① and ② as indicated in the diagram.

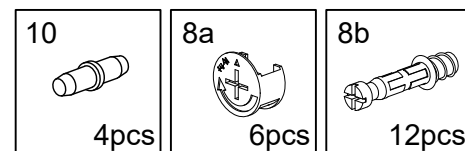

## Step 8

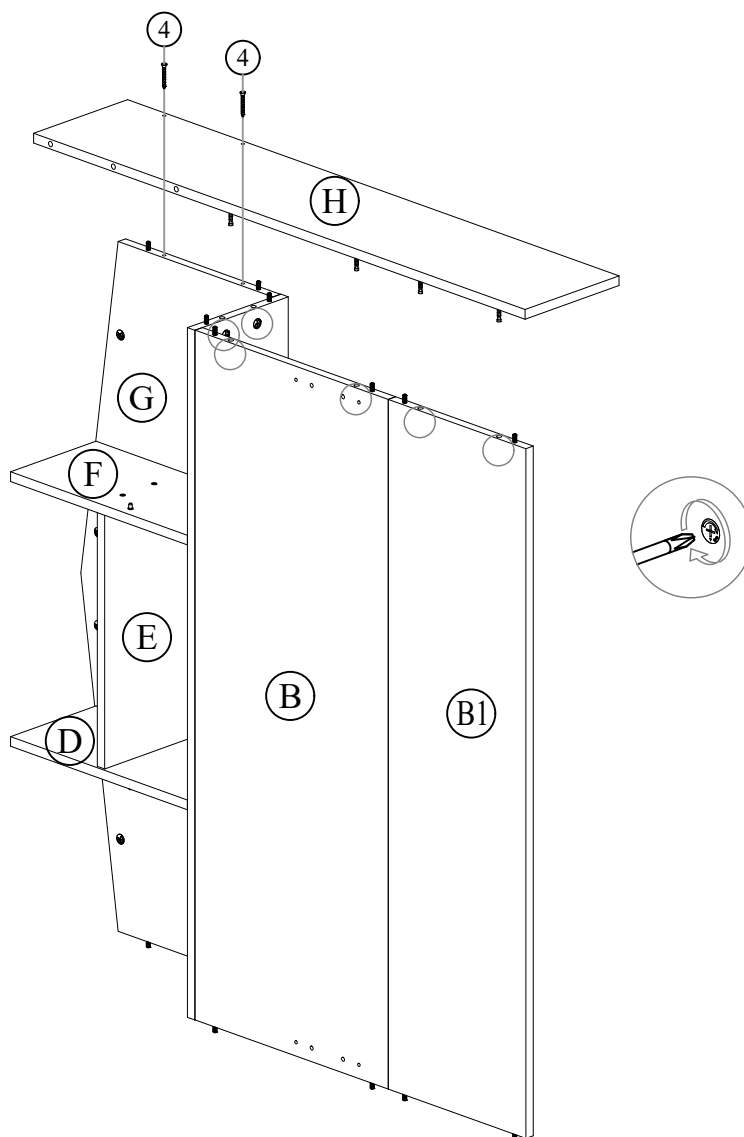

- Use the Allen Key ⑬ to tighten the M6X40MM Screws ④ securely.
- Assemble Panel ②, ③, ④, ⑤ and Panel ⑥ together, then rotate the mini fix nuts to secure the mini fix screws as shown in the diagram.

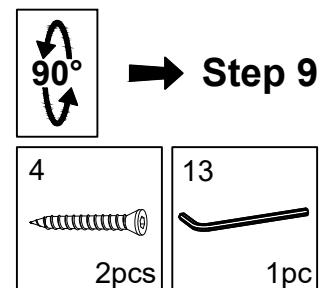

# Assembly Instruction

## Step 9

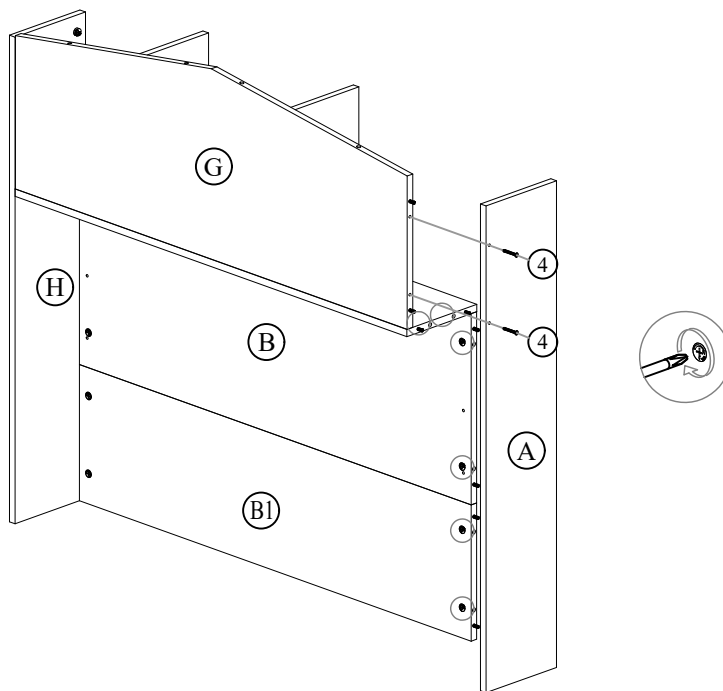

- Use the Allen Key (13) to tighten the M6X40MM Screws (4) securely.
- Assemble Panel (A), (G), (C), (B) and Panel (B1) together, then rotate the mini fix nuts to secure the mini fix screws as shown in the diagram.



➔ Step 10

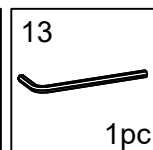
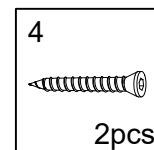

## Step 10

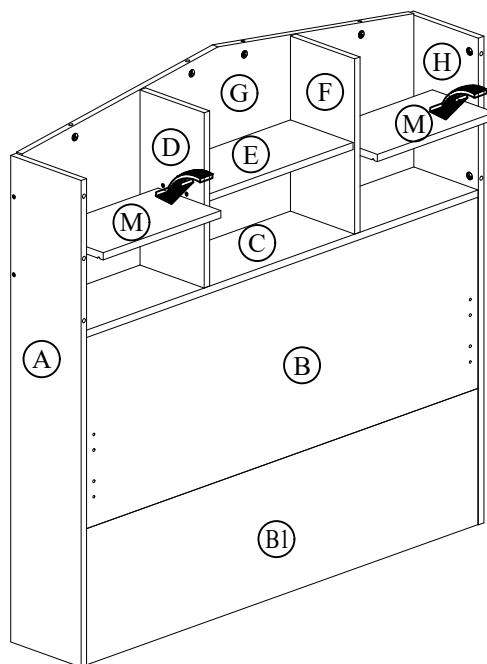

- Put Panel (M) onto attached Shelf Support on Panel (A), (D), (F) and (H)

# Assembly Instruction

## Step 11

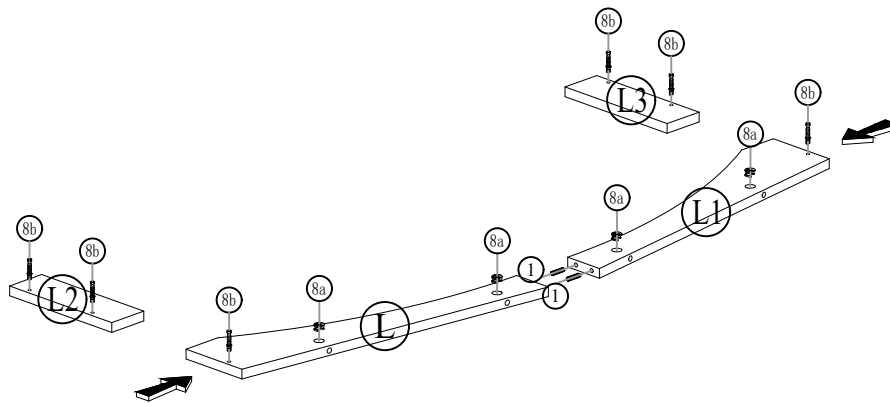

- Attach the mini fix nuts (8a) to Panel (L) and (L1) as indicated in the diagram.
- Attach the mini fix screws (8b) to Panel (L), (L1), (L2) and (L3) as indicated in the diagram.
- Install the 6x25mm pvc dowel (1) into Panel (L1) then connect it to Panel (L).

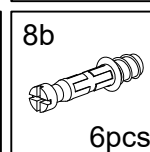
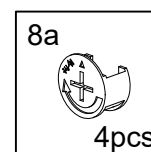
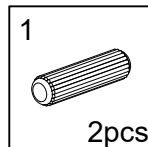

## Step 12

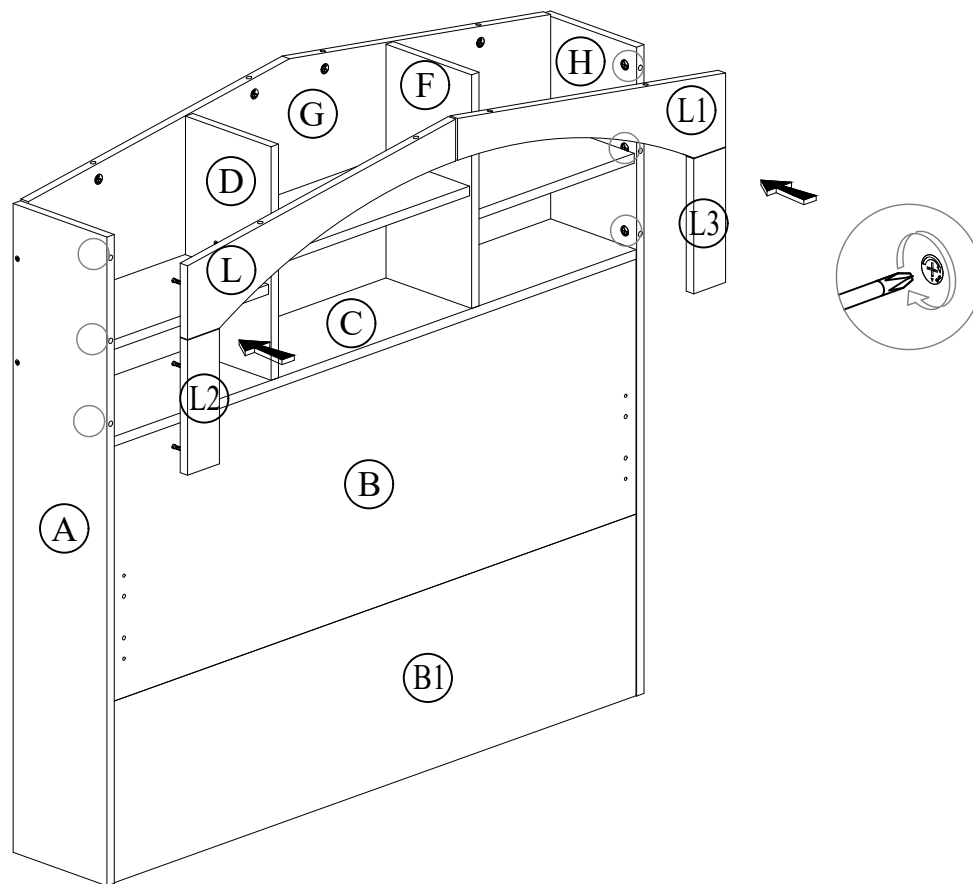

- Assemble Panel (A), (H), (L), (L1), (L2) and Panel (L3) together, then rotate the mini fix nuts to secure the mini fix screws as shown in the diagram.

# Assembly Instruction

## Step 13

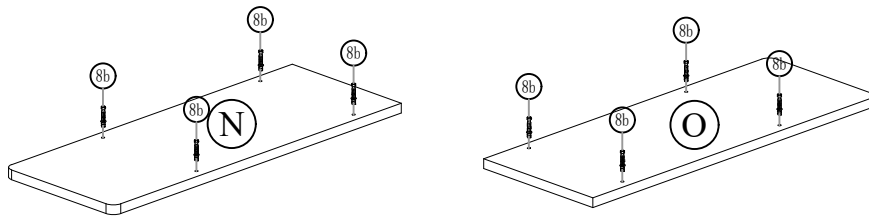

- Attach the mini fix screws (8b) to Panel (N) and (O) as indicated in the diagram.

8b



8pcs

## Step 14

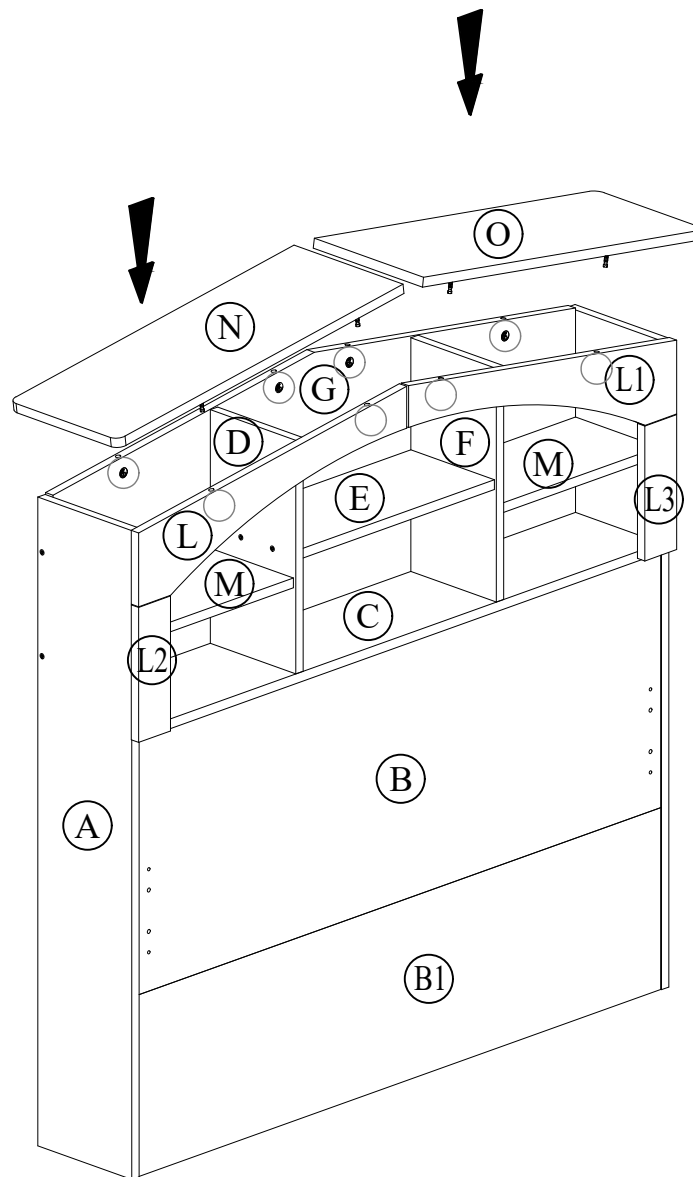

- Assemble Panel (N), (O), (G), (L) and Panel (L1) together, then rotate the mini fix nuts to secure the mini fix screws as shown in the diagram.

# Assembly Instruction

## Step 15

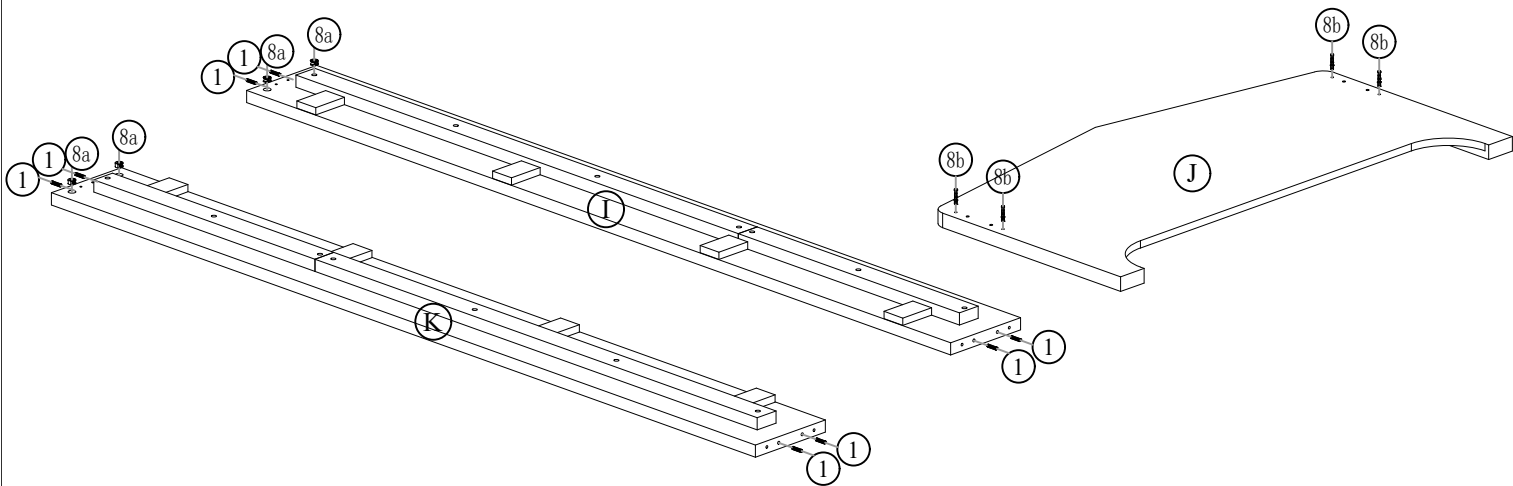

- Install the 6x25mm pvc dowel ① into Panel ③ and ① as shown in the diagram.
- Attach the mini fix nuts ⑧a to Panel ③ and ① as indicated in the diagram.
- Attach the mini fix screws ⑧b to Panel ② as indicated in the diagram.

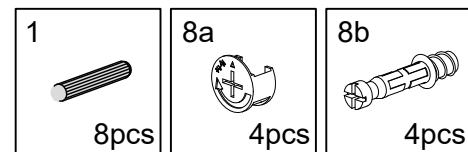

## Step 16

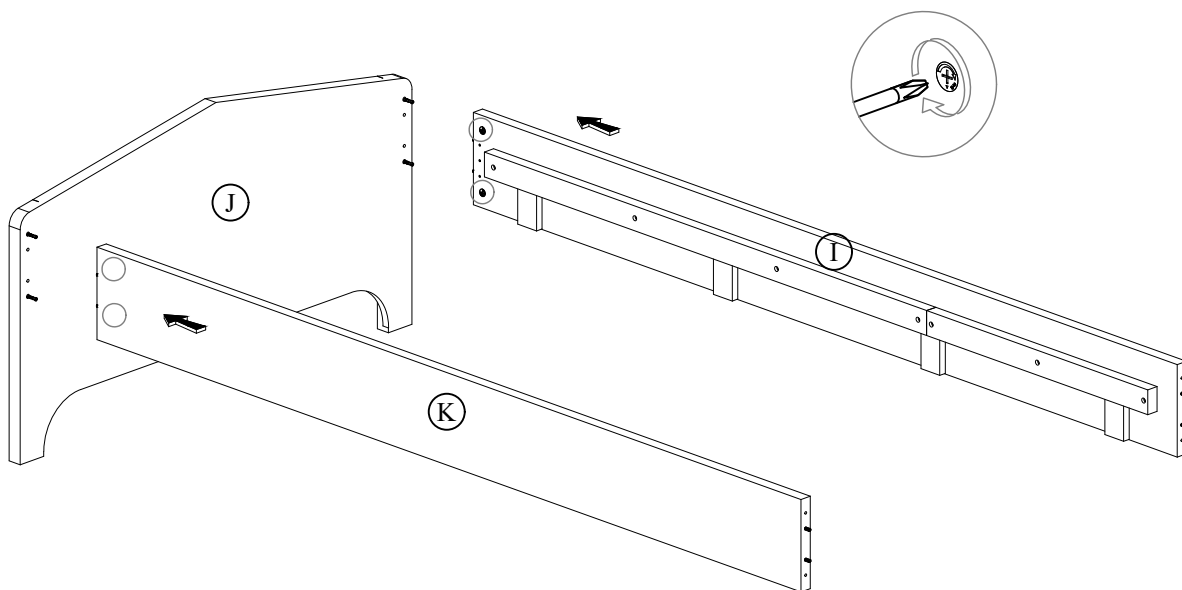

- Assemble Panel ①, ② and Panel ③ together, then rotate the mini fix nuts to secure the mini fix screws as shown in the diagram.

# Assembly Instruction

## Step 17

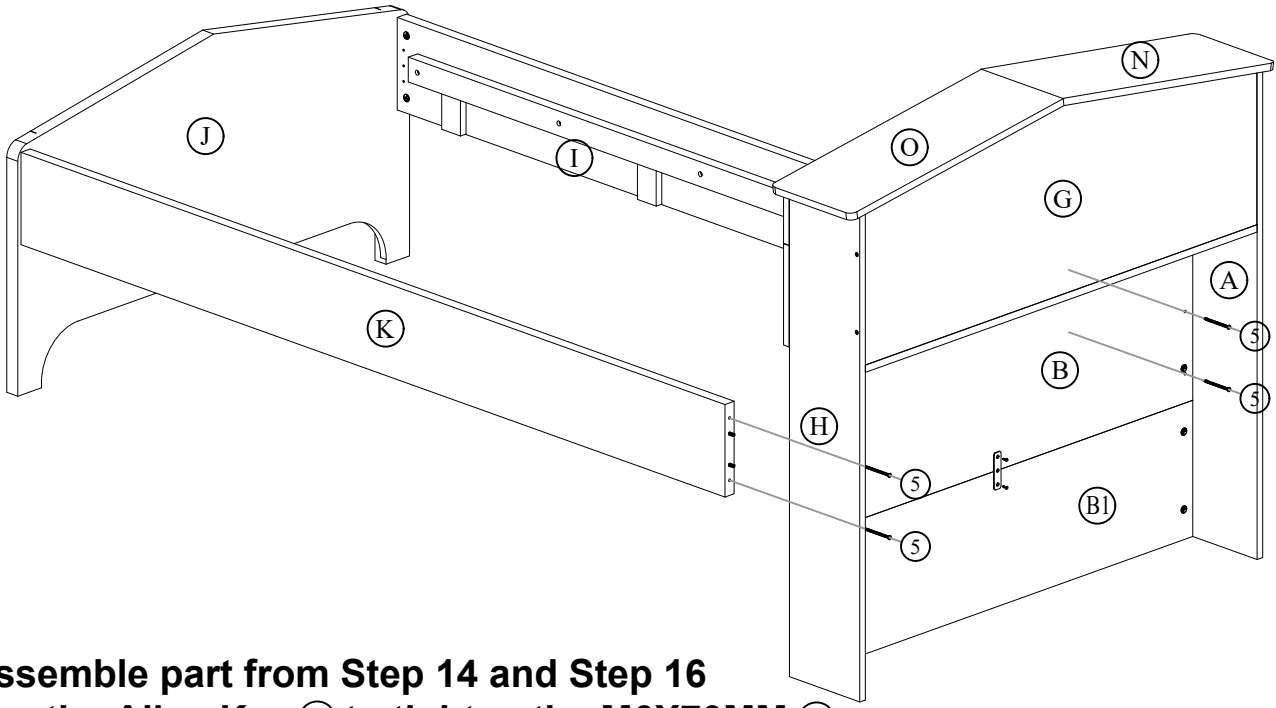

- Assemble part from Step 14 and Step 16
- Use the Allen Key ⑬ to tighten the M6X70MM ⑤ Screws securely.
- Place Metal Plate ⑫ on ② and ③, then use M3.5x14mm screw ② to tighten it.

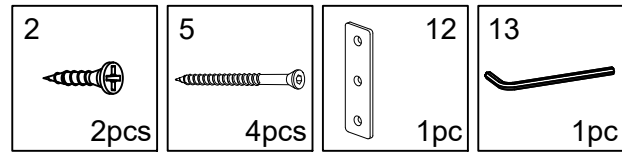
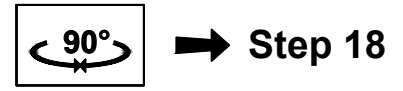

## Step 18

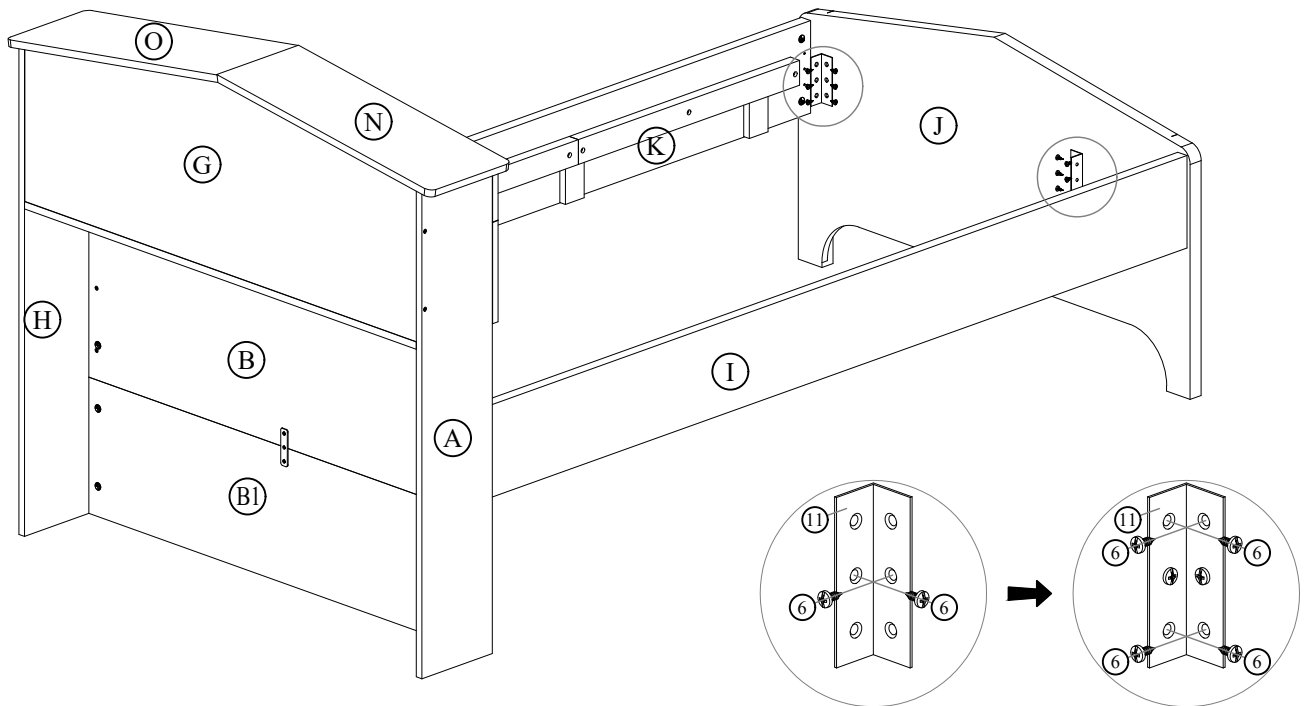

- Install L-Brackets ⑪ on corners between ②, ③ and ④, ⑤. Follow the diagram to install TP10#1/2" Screws ⑥ in the specified sequence.



# Assembly Instruction

## Step 19

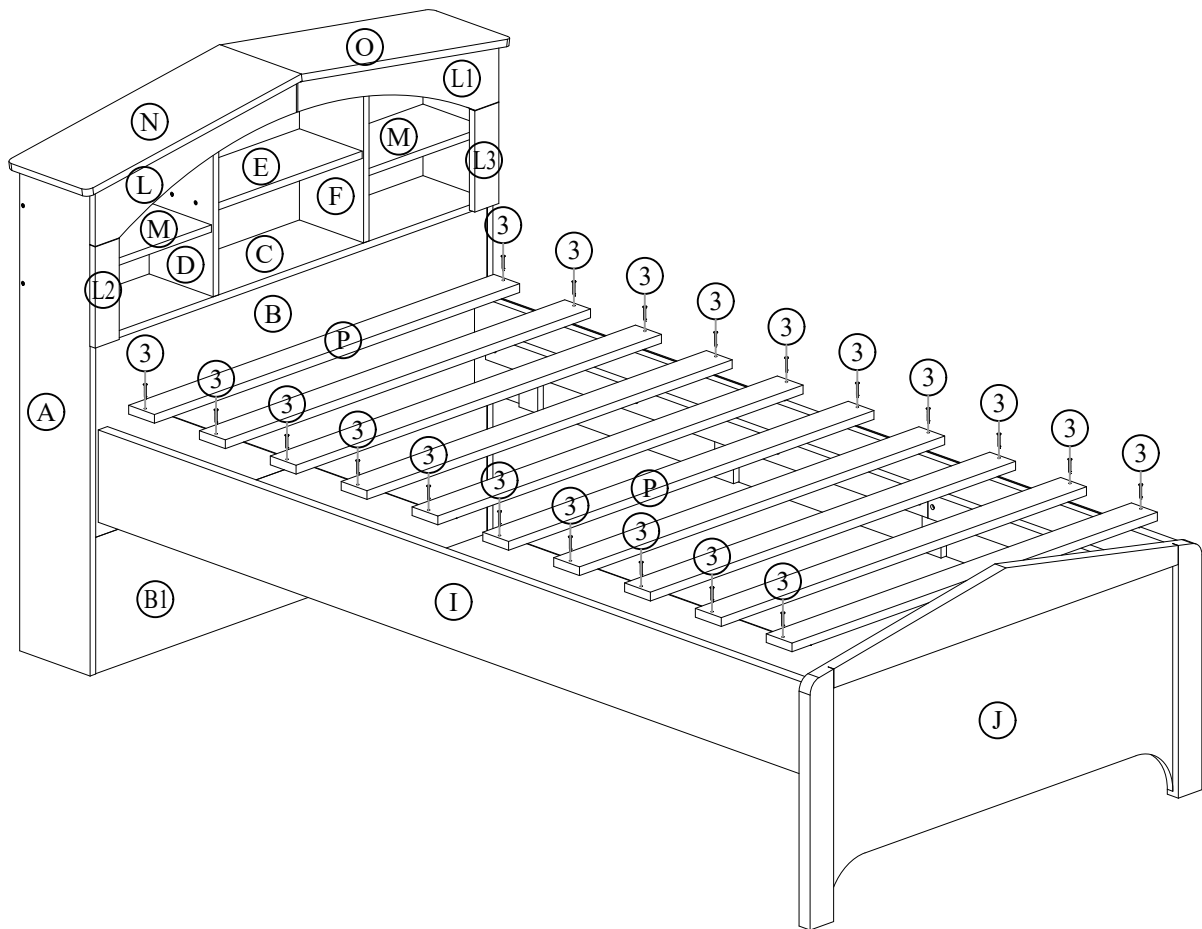

- Secure all Panel (P) using M4x32mm Screws (3) as shown in the diagram.

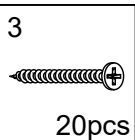

## Step 20

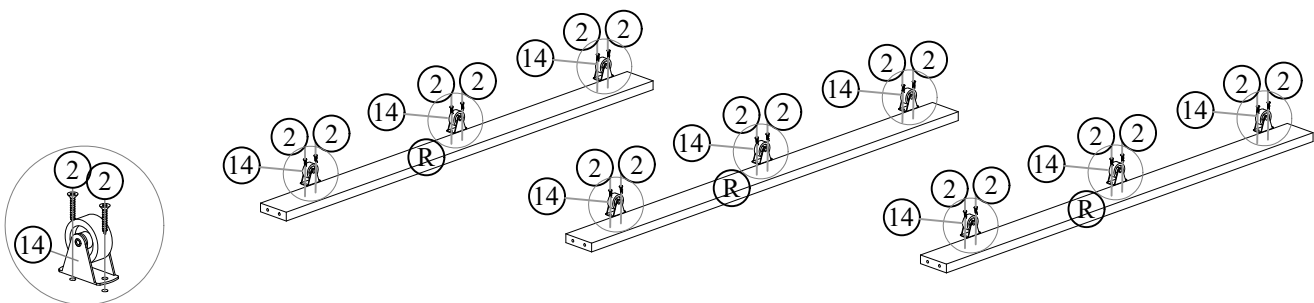

- Align the Rigid Caster (14) at left, center and right of Panel (R) then install using M3.5x14mm (2) Screws, as illustrated.

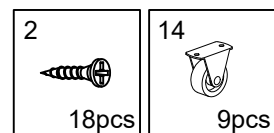



# Assembly Instruction

## Step 21

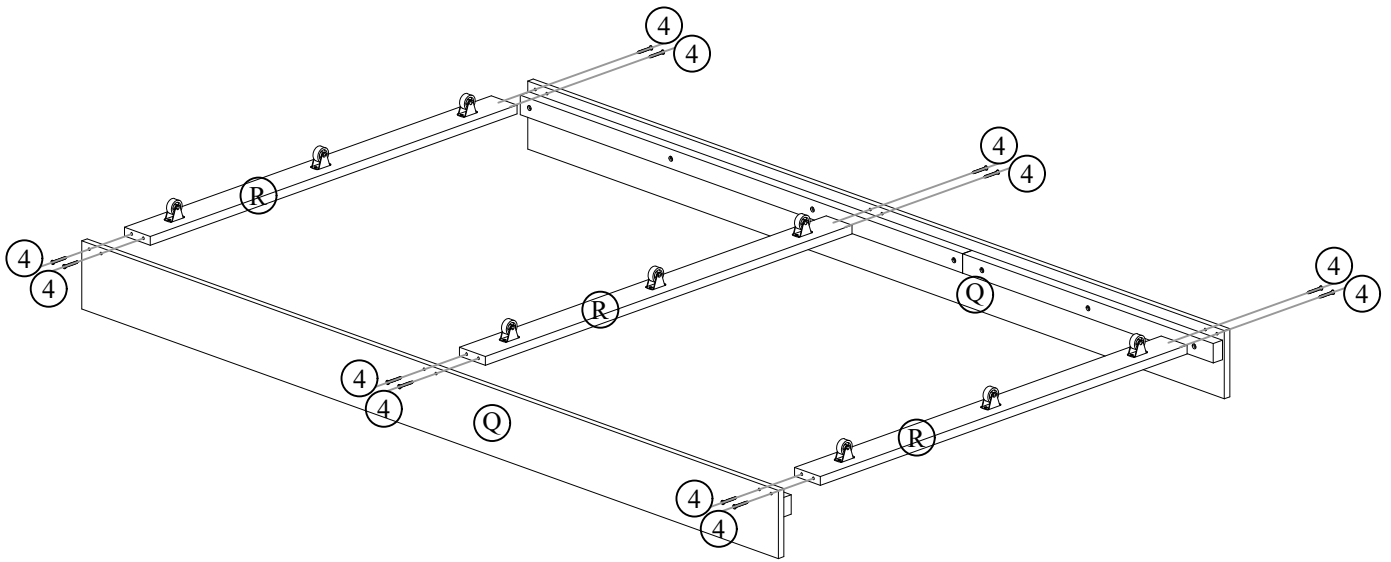

- Secure Panels ④ and ⑤ using M6X40MM ④ screws.
- Then use the Allen Key ⑬ to tighten the M6X40MM ④ Screws securely.

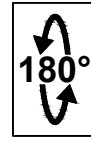

➔ Step 22

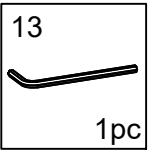
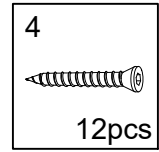

## Step 22

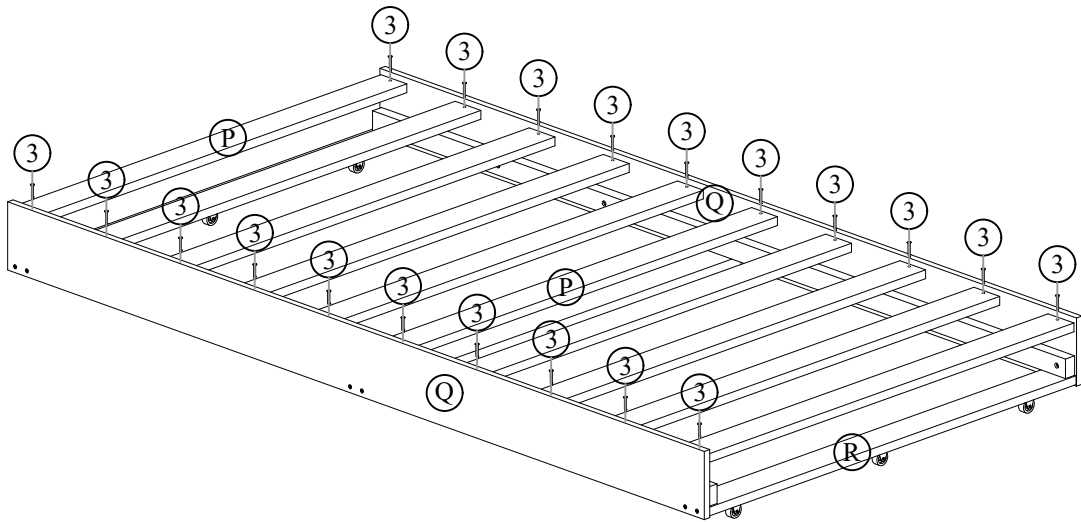

- Secure all Panel ⑥ using M4x32mm Screws ③ as shown in the diagram.

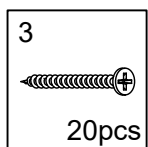

# Assembly Instruction

## Step 23

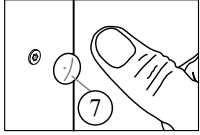

\* Cover all the screw (4) (5)'s head with the pvc cap provided by pushing the cover's stem onto the hole of screw head.

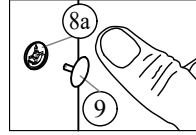

\* Cover all the mini fix (nuts) (8a)'s head with the pvc cap provided by pushing the cover's stem onto the hole mini fix (nuts).

## Complete

