

# ASSEMBLY INSTRUCTIONS

WF 310878/WF 310879

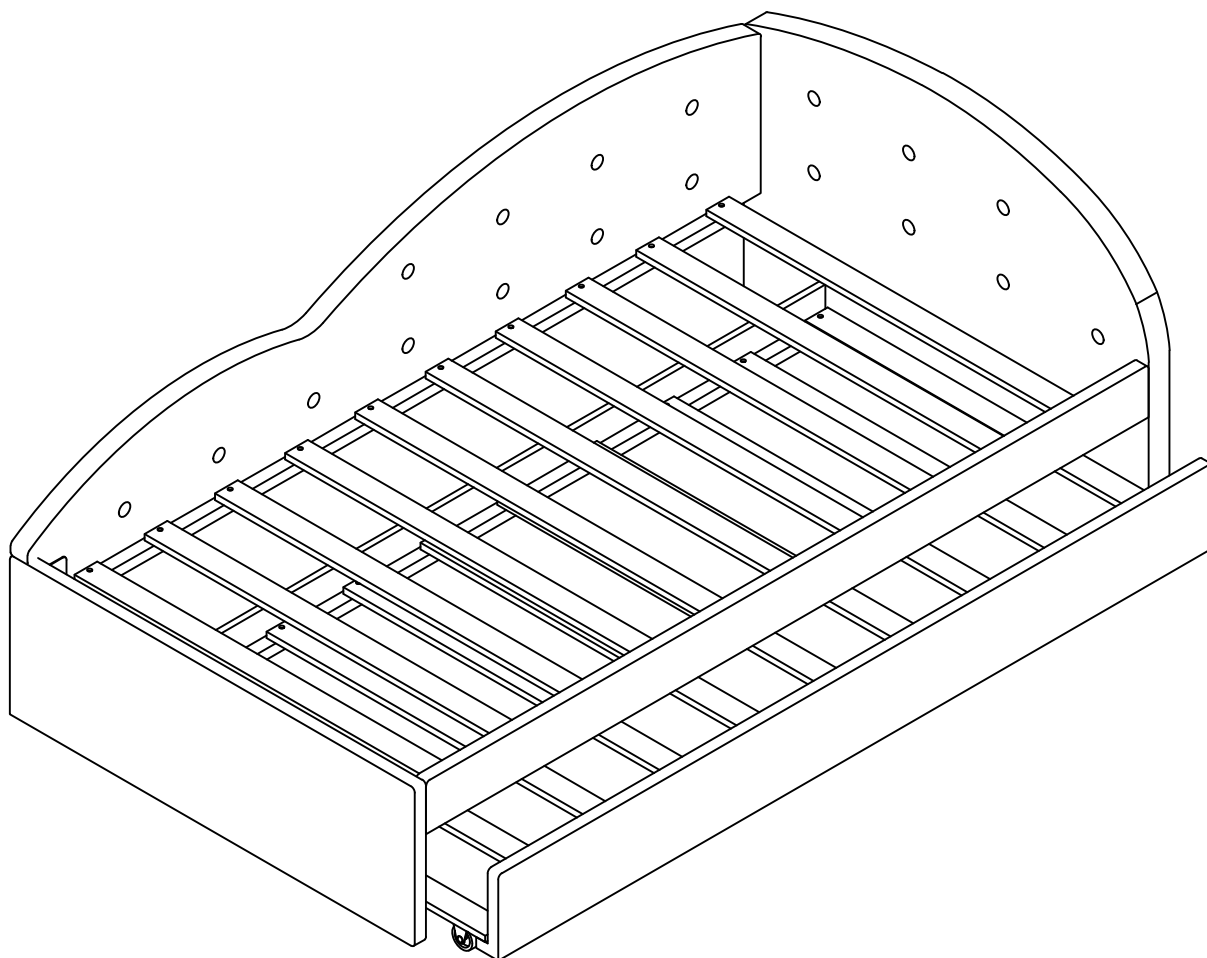

## IMPORTANT NOTE

**\*\*PLACE ALL PARTS ON A CLEAN AND SMOOTH SURFACE SUCH AS A RUG OR CARPET TO AVOID THE PARTS FROM BEING SCRATCHED**

**\*\* BEFORE YOU BEGIN , KINDY FOLLOW THE ASSEMBLY INSTRUCTIONS STEP BY STEP**

**\*\*DO NOT TIGHTEN ALL SCREWS AND BOLTS UNTIL THE BED IS FULLY SET-UP**

# ASSEMBLY INSTRUCTIONS

WF 310878/WF 310879

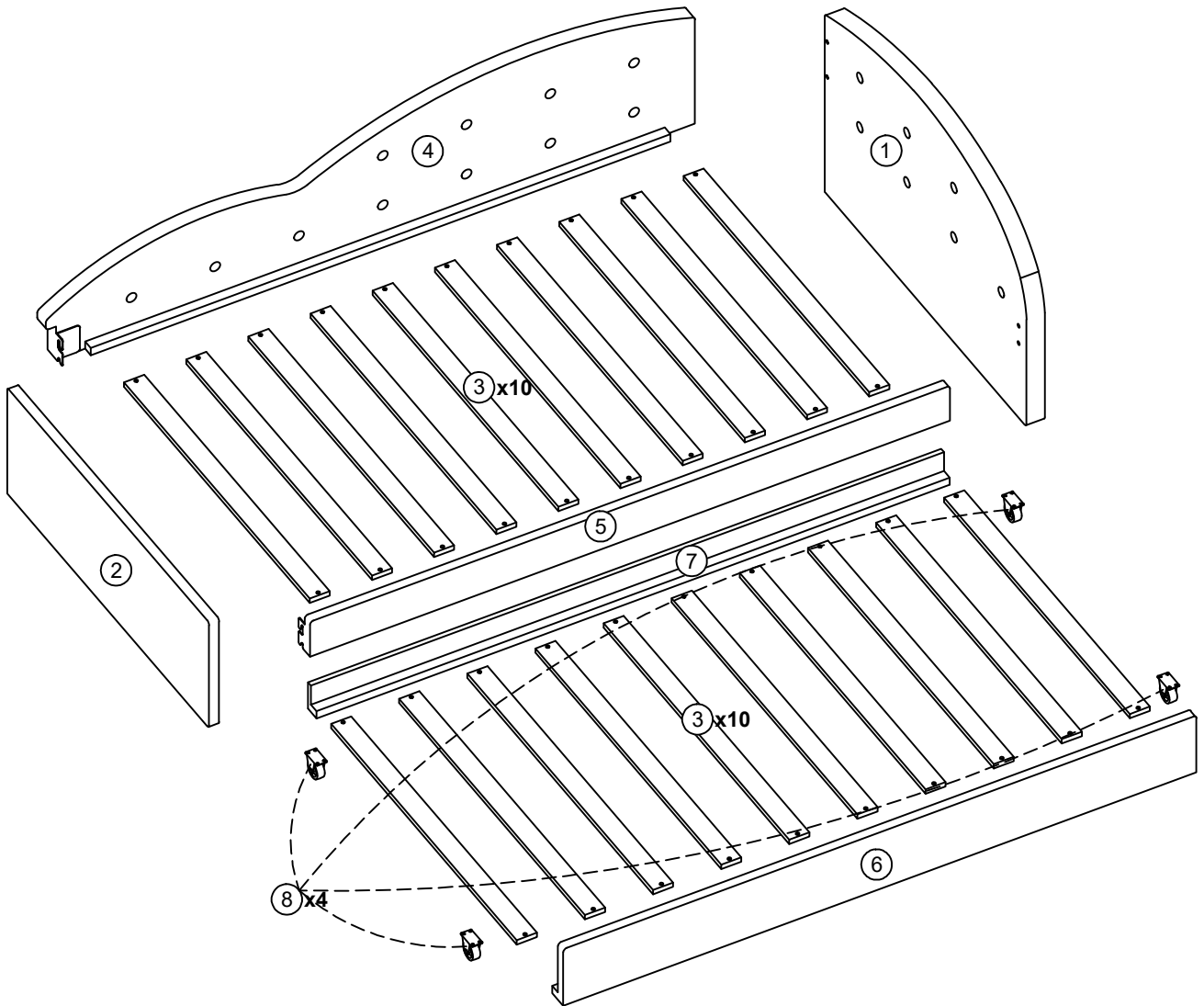

# ASSEMBLY INSTRUCTION

WF 310878/WF 310879

## PART LIST IN: WF 310878

1

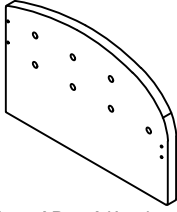

Headboard Panel (1 pc)

2

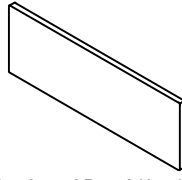

Footboard Panel (1 pc)

3

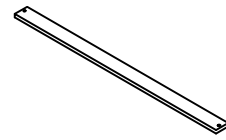

Roll Slat (20 pcs)  
985\*60\*15

## PART LIST BOX 2: WF 310879

4

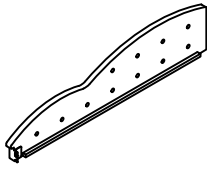

Left Side Rail (1 pc)

5

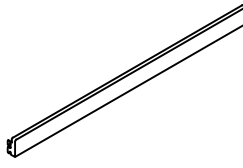

Right Side Rail (1 pc)

6

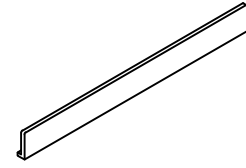

Trundle Front Panel (1 pc)

7

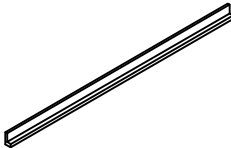

Trundle Back Panel (1 pc)

8







Wheels (4 pcs)  
59x42x66mm

# ASSEMBLY INSTRUCTIONS

WF 310878/WF 310879

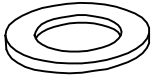
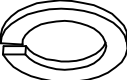
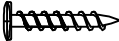
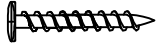
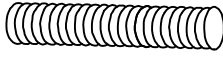

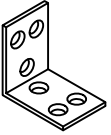

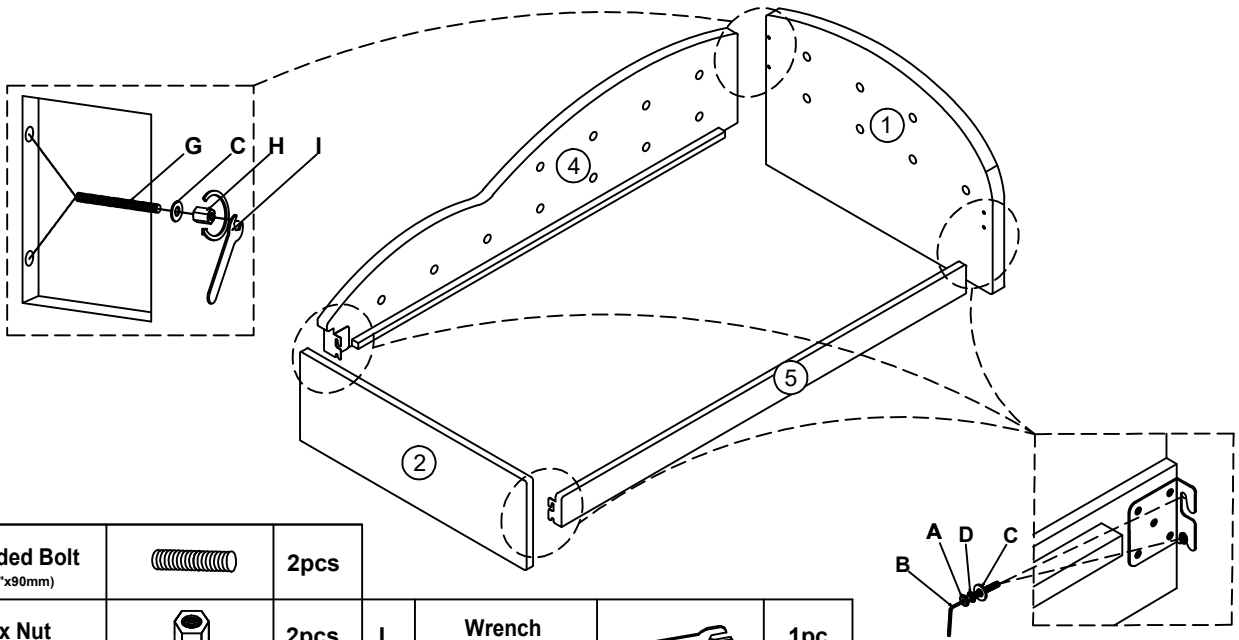

## HARDWARE LIST IN WF 310879

<p><b>A</b></p>  <p><b>Short Bolt (6 pcs)</b> (5/16 "X25mm)</p>	<p><b>B</b></p>  <p><b>Allen Wrench (1 pc)</b> (M4x75mm x32mm)</p>	<p><b>C</b></p>  <p><b>Flat Washer (8 pcs)</b></p>
<p><b>D</b></p>  <p><b>Spring Washer (6 pcs)</b></p>	<p><b>E</b></p>  <p><b>Flat Head Screw (40 pcs)</b> ( m4x15mm)</p>	<p><b>F</b></p>  <p><b>Flat Head Screw (40 pcs)</b> ( m4x30mm)</p>
<p><b>G</b></p>  <p><b>Threaded Bolt (2 pcs)</b> (5/16"X90mm )</p>	<p><b>H</b></p>  <p><b>Hex Nut (2 pcs)</b> (16mmx13mmx13mm)</p>	<p><b>I</b></p>  <p><b>Wrench (1 pc)</b></p>
<p><b>K</b></p>  <p><b>L Bracket (4 pcs)</b> (38mmx38mmx25mmx2mm)</p>		

# ASSEMBLY INSTRUCTIONS

## STEP 1



G	<b>Threaded Bolt</b> (5/16" x 90mm)		2pcs			
H	<b>Hex Nut</b> (16x13x13mm)		2pcs	I	<b>Wrench</b>	 1pc
A	<b>Bolt</b> (5/16" x 25mm)		6pcs	D	<b>Spring Washer</b>	 6pcs
B	<b>Allen Wrench</b> (M4x75mm x32mm)		1pc	C	<b>Flat Washer</b>	 8pcs

## STEP 2

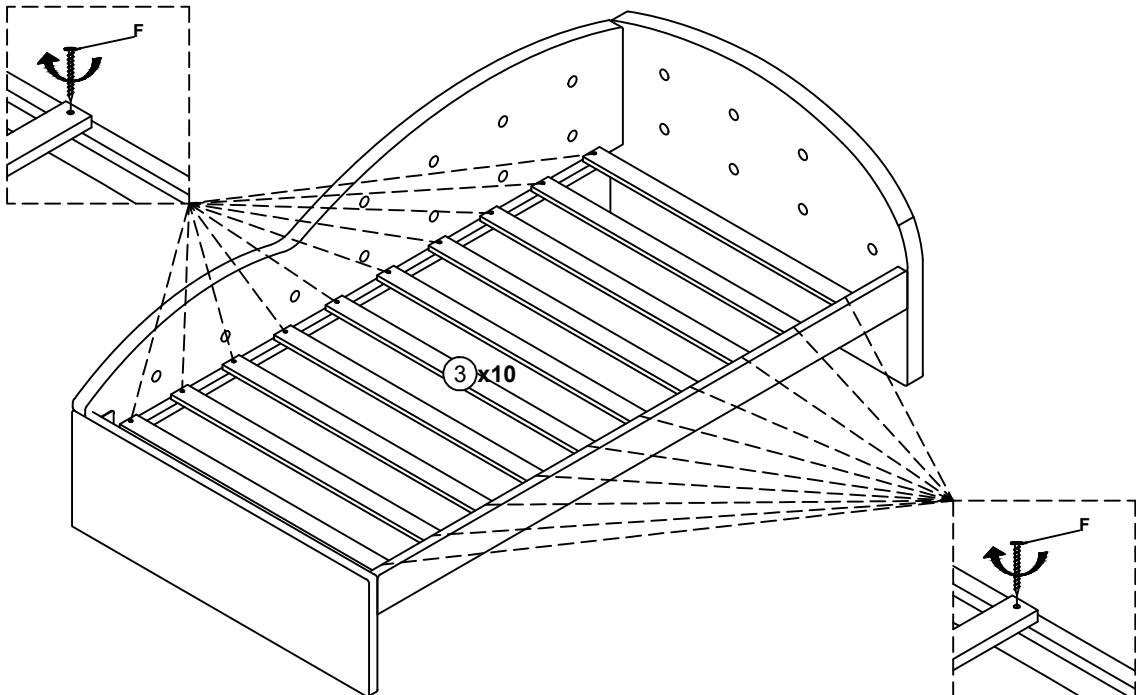

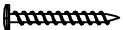

F	<b>Flat Head Screw</b> (m4x30mm)		20pcs
---	-------------------------------------	---	-------

# ASSEMBLY INSTRUCTIONS

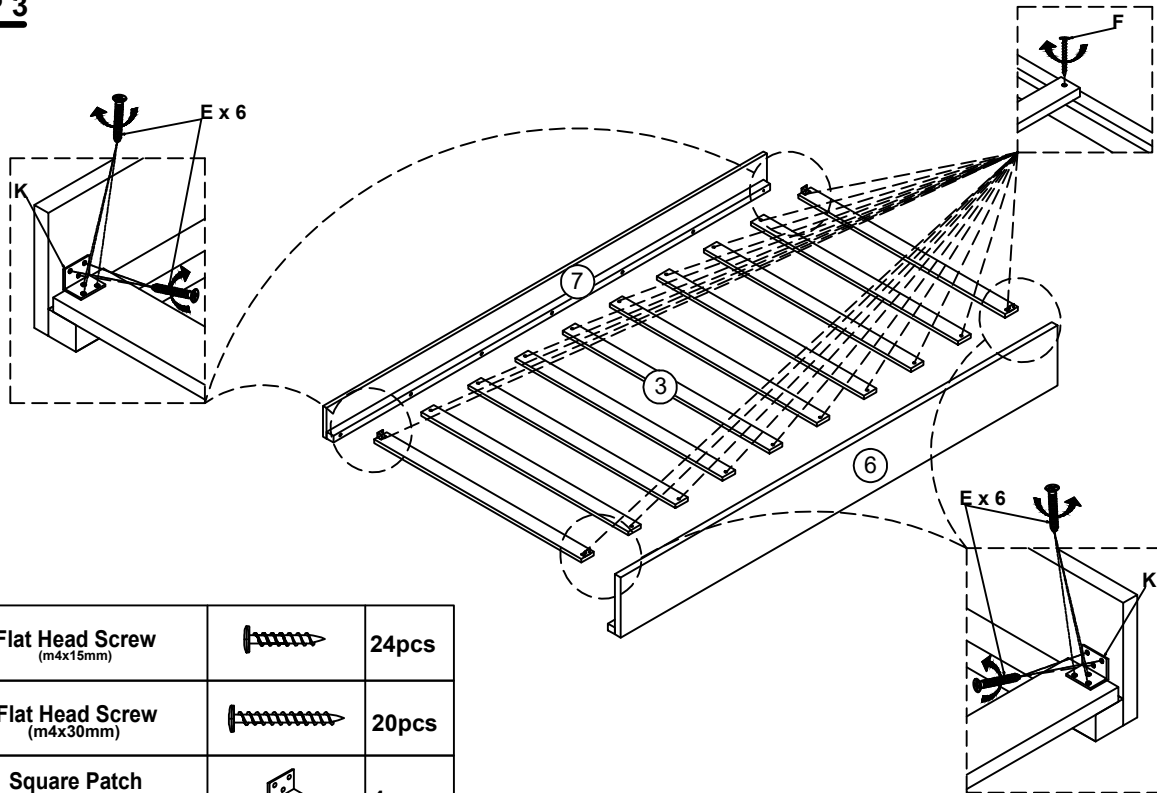
## STEP 3

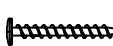

E	Flat Head Screw (m4x15mm)		24pcs
F	Flat Head Screw (m4x30mm)		20pcs
K	Square Patch (38mmx38mmx25mmx2mm)		4pcs

## STEP 4

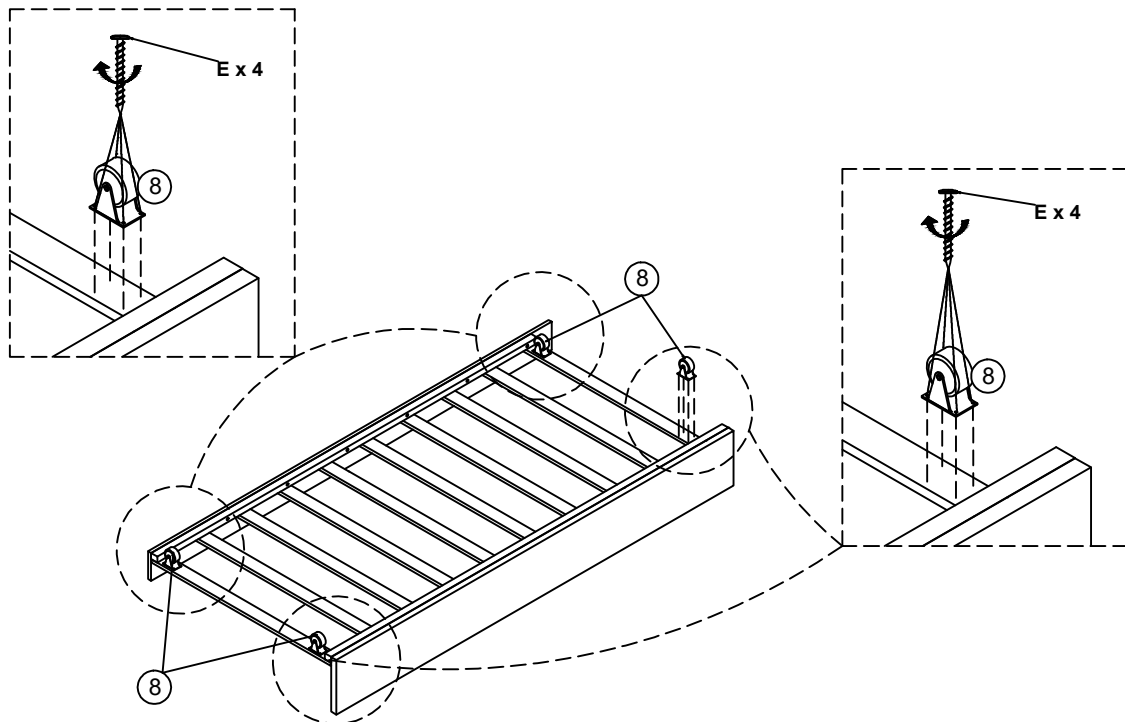

E	Flat Head Screw (m4x15mm)		16pcs
---	------------------------------	---	-------

# ASSEMBLY INSTRUCTIONS

**STEP 5**  
**COMPLETE**

