

ASSEMBLY INSTRUCTIONS

WF 302056/ WF 302057

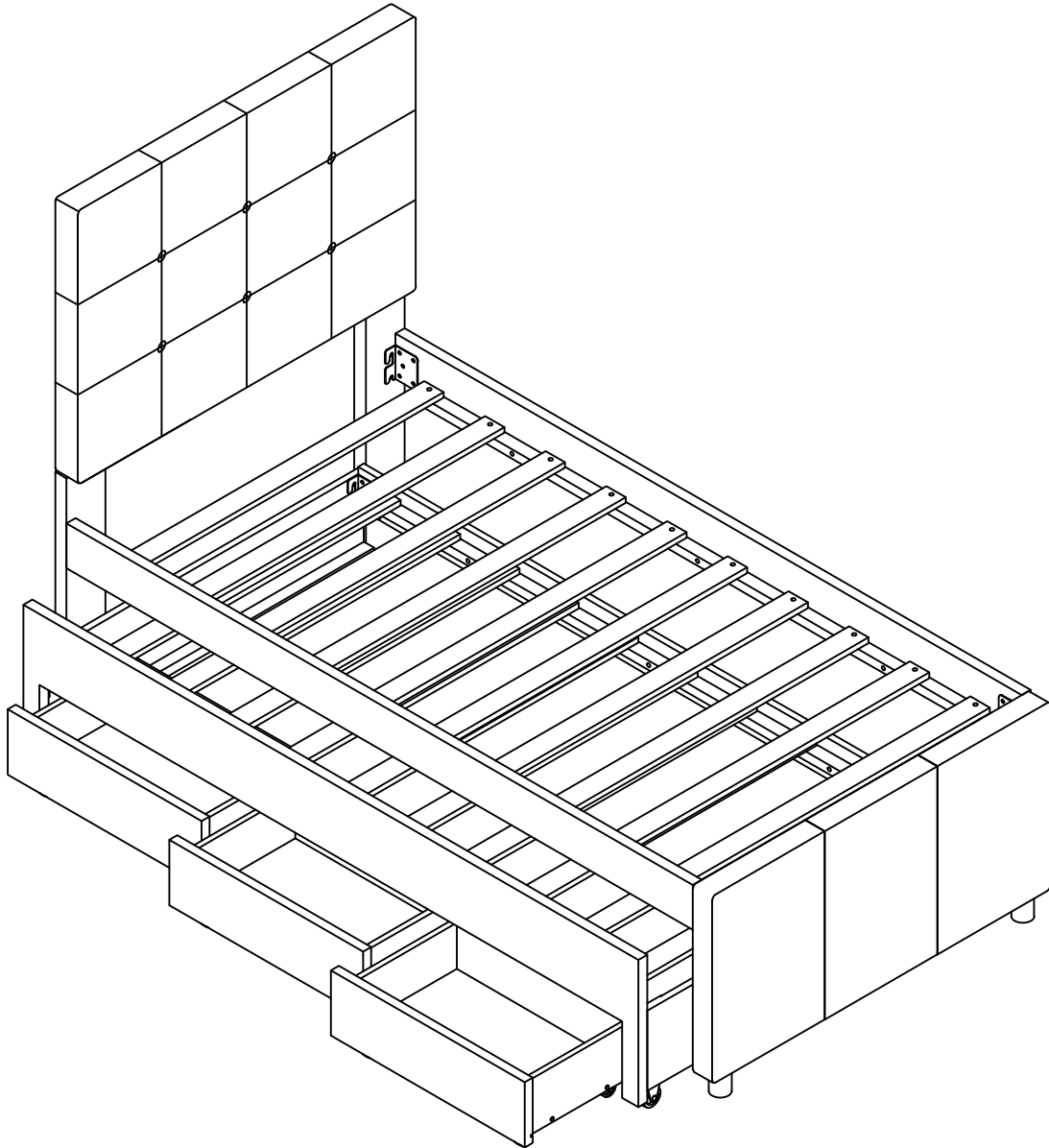

IMPORTANT NOTE

****PLACE ALL PARTS ON A CLEAN AND SMOOTH SURFACE SUCH AS A RUG OR CARPET TO AVOID THE PARTS FROM BEING SCRATCHED**

**** BEFORE YOU BEGIN , KINDY FOLLOW THE ASSEMBLY INSTRUCTIONS STEP BY STEP**

****DO NOT TIGHTEN ALL SCREWS AND BOLTS UNTIL THE BED IS FULLY SET-UP**





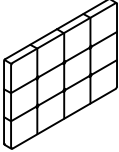
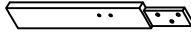
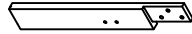
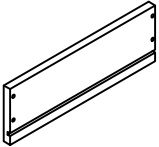
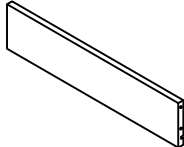
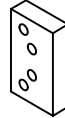
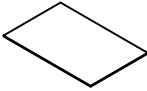
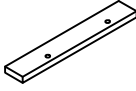
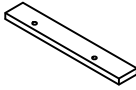
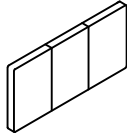
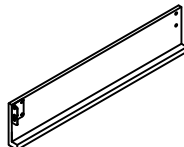
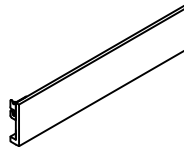
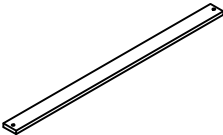

ASSEMBLY INSTRUCTIONS

WF 302056/ WF 302057

PART LIST BOX 1: WF 302056

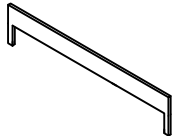
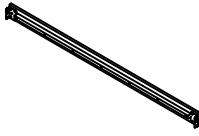
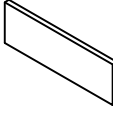
<p>1</p>  <p>Headboard (1 pc)</p>	<p>2</p>  <p>Left Headboard Leg (1 pc)</p>	<p>3</p>  <p>Right Headboard Leg (1 pc)</p>
<p>4</p>  <p>Side Pull Box (6 pcs)</p>	<p>5</p>  <p>Back Panel Pull Box (3 pcs)</p>	<p>6</p>  <p>Stand in Pull Box (6 pcs)</p>
<p>7</p>  <p>Pull Box Bottom Board (3 pcs)</p>	<p>8</p>  <p>Drawer Bottom Rail (3 pcs)</p>	<p>9</p>  <p>Drawer Bottom Rail (3 pcs)</p>
<p>10</p>  <p>Footboard (1 pc)</p>	<p>11</p>  <p>Left Trundle End Panel (1 pc)</p>	<p>12</p>  <p>Right Trundle End Panel (1 pc)</p>
<p>13</p>  <p>Roll Slat (20 pcs) 985*60*15mm</p>		







PART LIST BOX 1: WF 302057

<p>14</p>  <p>Left Lower Rail (1 pc)</p>	<p>15</p>  <p>Right Lower Rail (1pc)</p>	<p>16</p>  <p>Front Panel Trundle (1 pc)</p>
<p>17</p>  <p>Back Panel Trundle (1 pc)</p>	<p>18</p>  <p>Pull Box Bottom Board (3pcs)</p>	<p>19</p>  <p>Leg (2 pcs)</p>
<p>20</p>  <p>(m47x25mmx50mm) Wheels (12pcs)</p>	<p>21</p>  <p>(m59x42mmx66mm) Wheels (4 pcs)</p>	

ASSEMBLY INSTRUCTIONS

WF 302056/ WF 302057

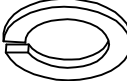
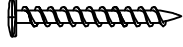
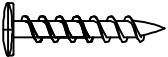
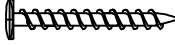
HARDWARE LIST IN WF 302057

A  (Ø 5/16 "X20mm) Short Bolt (16pcs)	B  (Ø 5/16 "X38mm) Long Bolt (6 pcs)	C  (M4x75mm x32mm) Allen Wrench (1 pc)
D  (Ø 5/16 "-RBW) Flat Washer (22 pcs)	E  (Ø 5/16 "-RBW) Spring Washer (22pcs)	F  (m4x30mm-RBW) Flat Head Screw (52 pcs)
G  (m4x20mm-RBW) Flat Head Screw (64 pcs)	H  (m4x38mm-RBW) Flat Head Screw (36 pcs)	I  (Ø10x10mm x10mm) Plastic Button (36pcs)



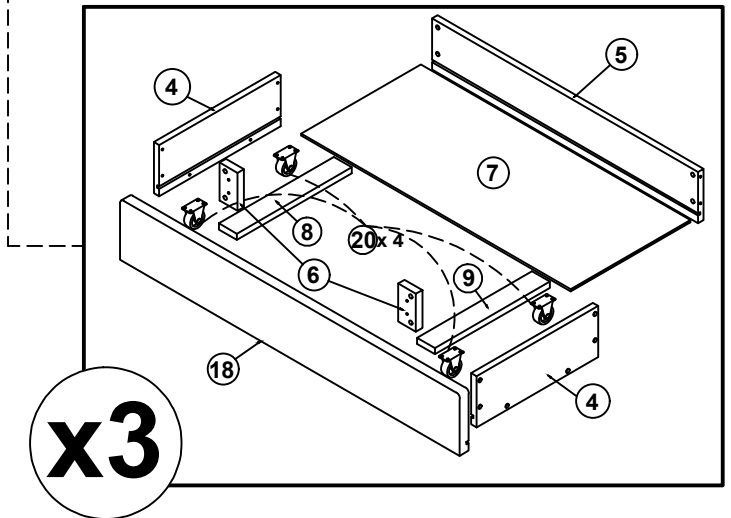
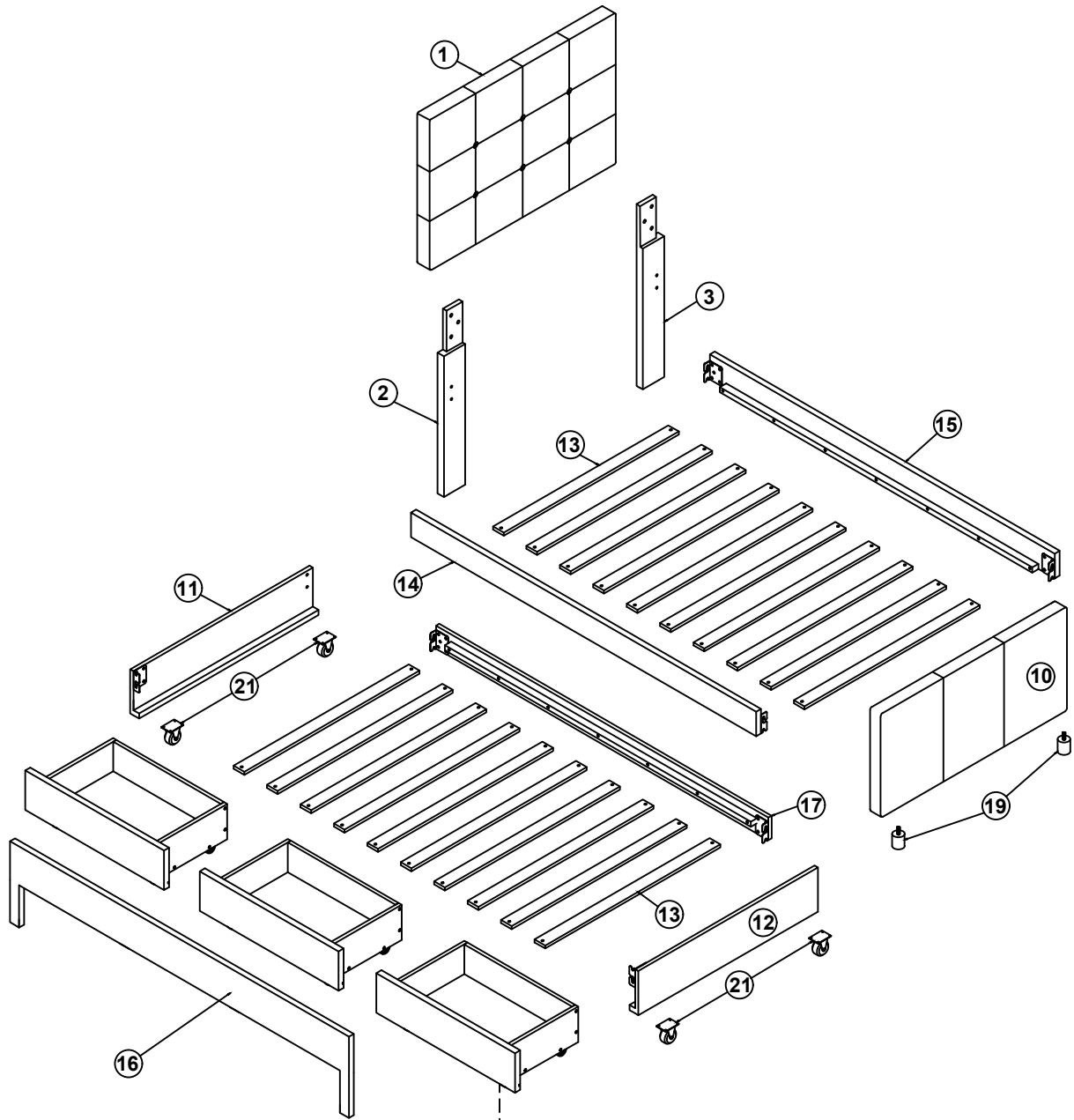

Exploded View

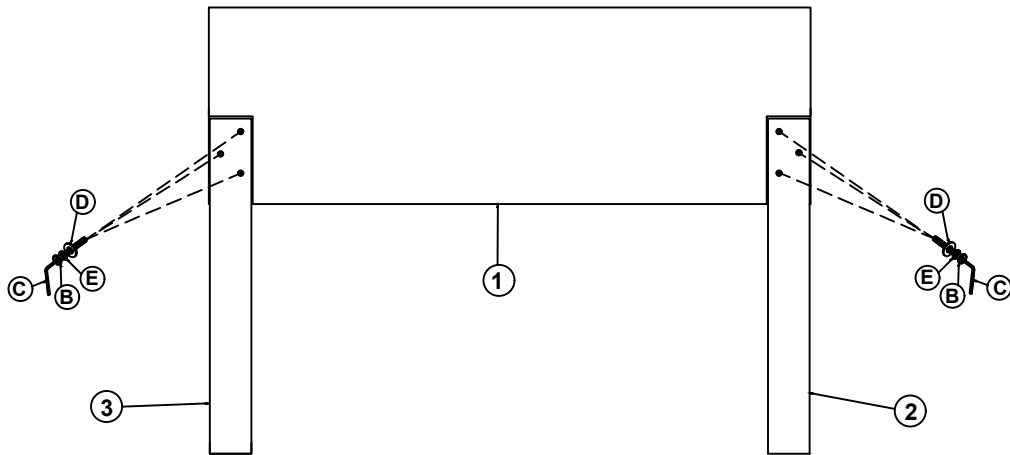

ASSEMBLY INSTRUCTIONS

STEP 1



B	Bolt (Ø 5/16 "X38mm)		6pcs	D	Flat Washer (Ø 5/16 "-RBW)		6pcs
E	Spring Washer (Ø 5/16 "-RBW)		6pcs	C	Allen Wrench (M4x75mm x32mm)		1pc



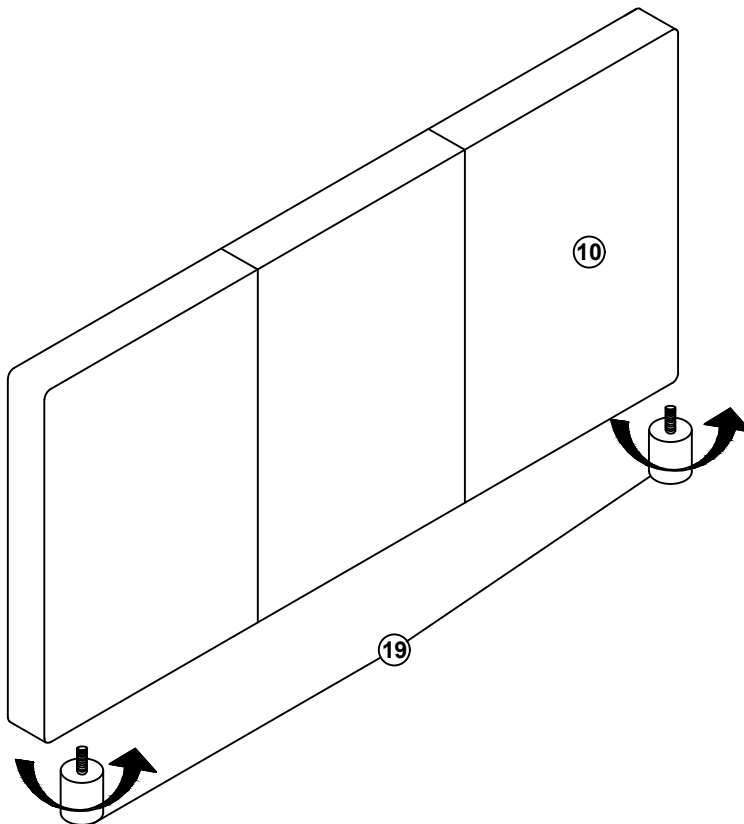

STEP 2

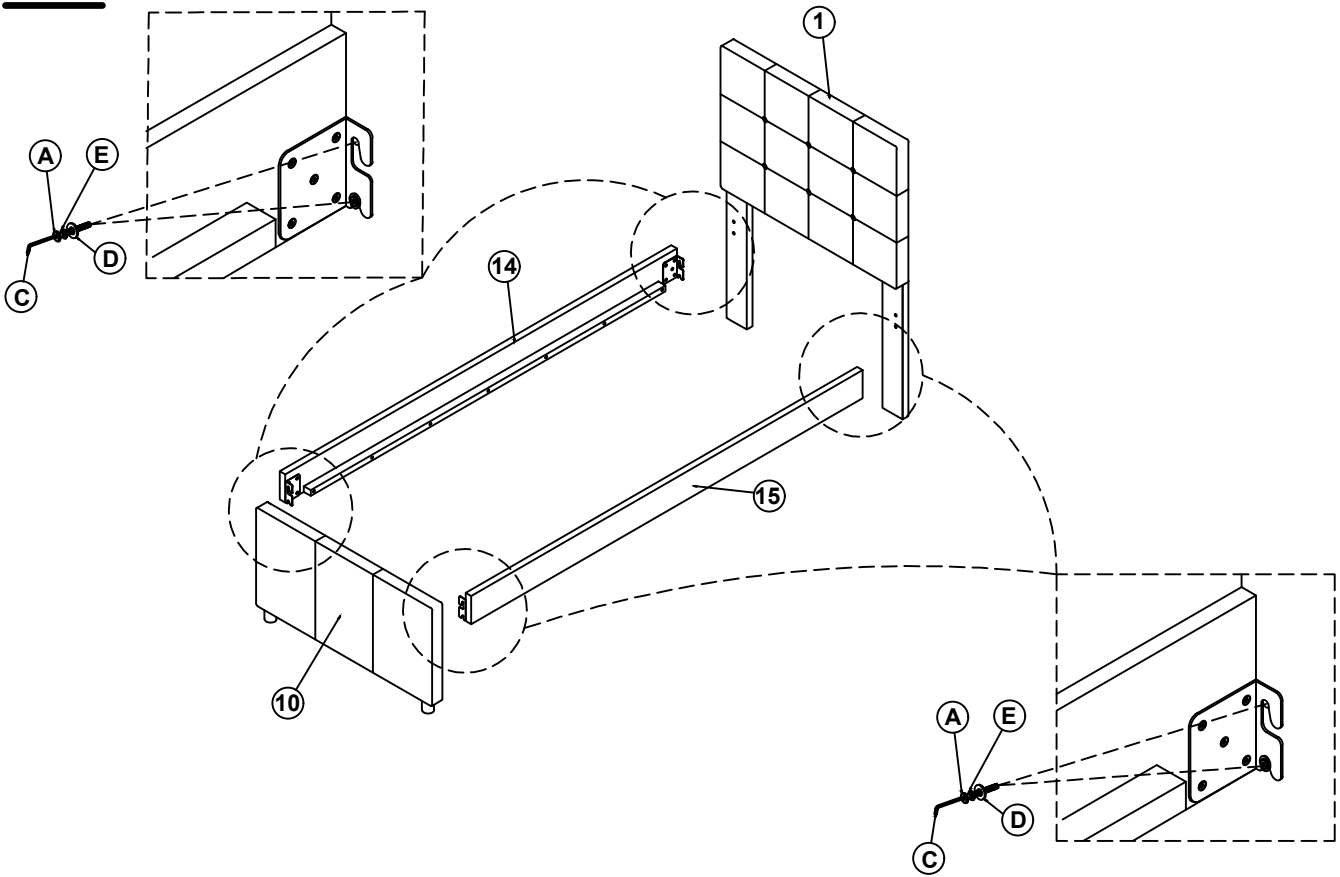

ASSEMBLY INSTRUCTIONS

STEP 3



A	Bolt (Ø 5/16 "X20mm)		8pcs	D	Flat Washer (Ø 5/16 "-RBW)		8pcs
E	Spring Washer (Ø 5/16 "-RBW)		8pcs	C	Allen Wrench (M4x75mm x32mm)		1pc

STEP 4

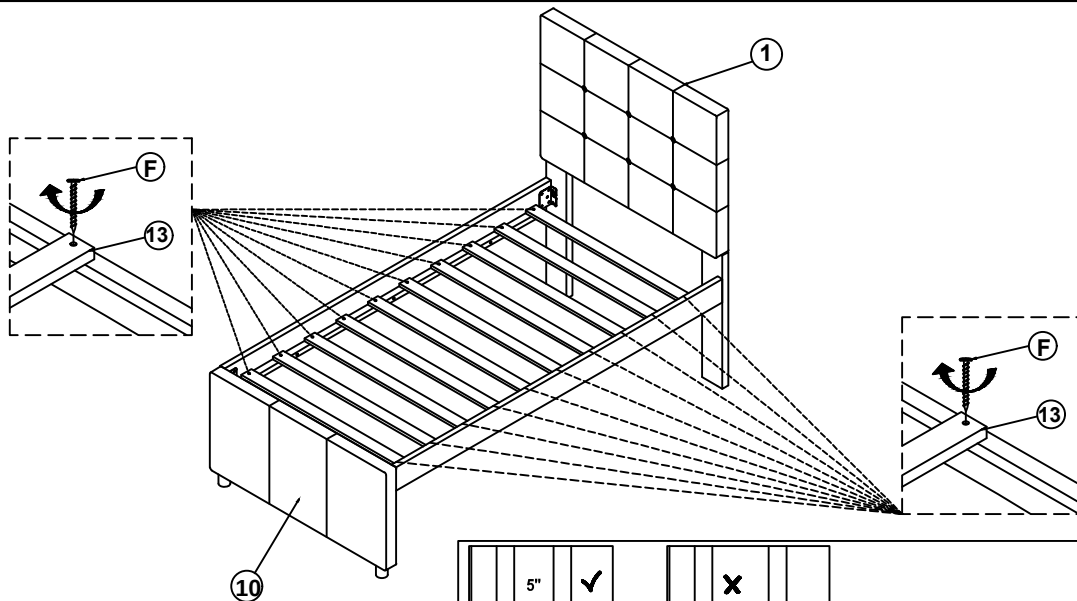

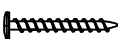
F	Flat Head Screw (m4x30mm-RBW)		20pcs
---	-----------------------------------------	-------------------------------------------------------------------------------------	-------

NOTE: Do not lock the screws of the trundle slats to the utermost edge the trundle slats, you need to leave a certain space at the edges, otherwise it will cause the board to break.

ASSEMBLY INSTRUCTIONS

STEP 5

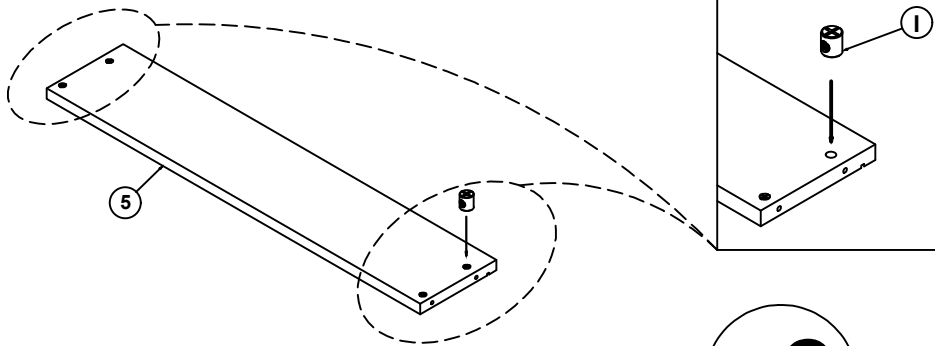

x3

1	Plastic Button (Ø10x10mmx10mm)		12pcs
---	-----------------------------------	-----------------------------------------------------------------------------------	-------

STEP 6

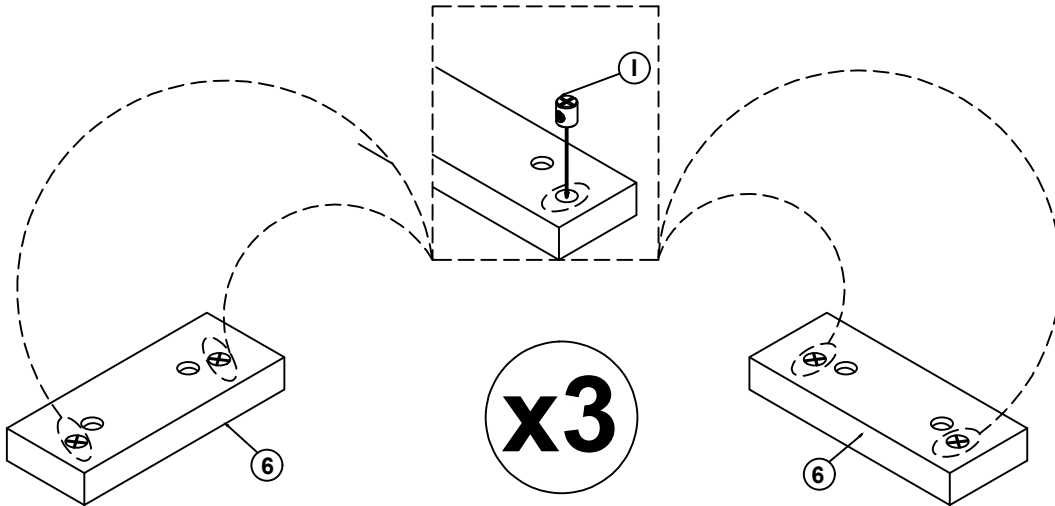

x3

1	Plastic Button (Ø10x10mmx10mm)		12pcs
---	-----------------------------------	-------------------------------------------------------------------------------------	-------

STEP 7

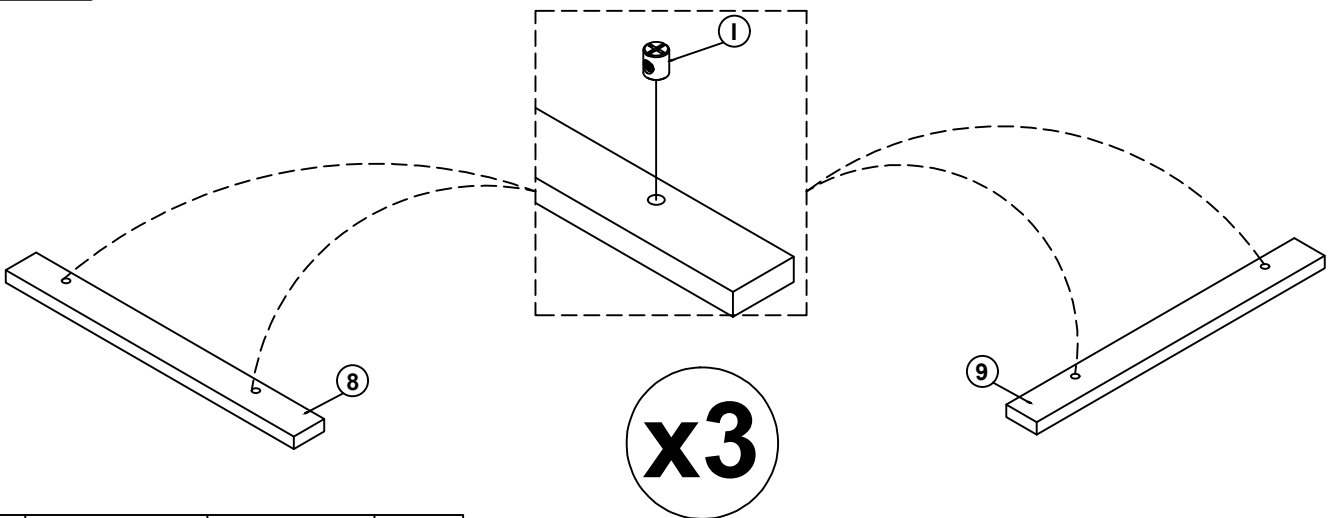

x3

1	Plastic Button (Ø10x10mmx10mm)		12pcs
---	-----------------------------------	-------------------------------------------------------------------------------------	-------

ASSEMBLY INSTRUCTIONS

STEP 8

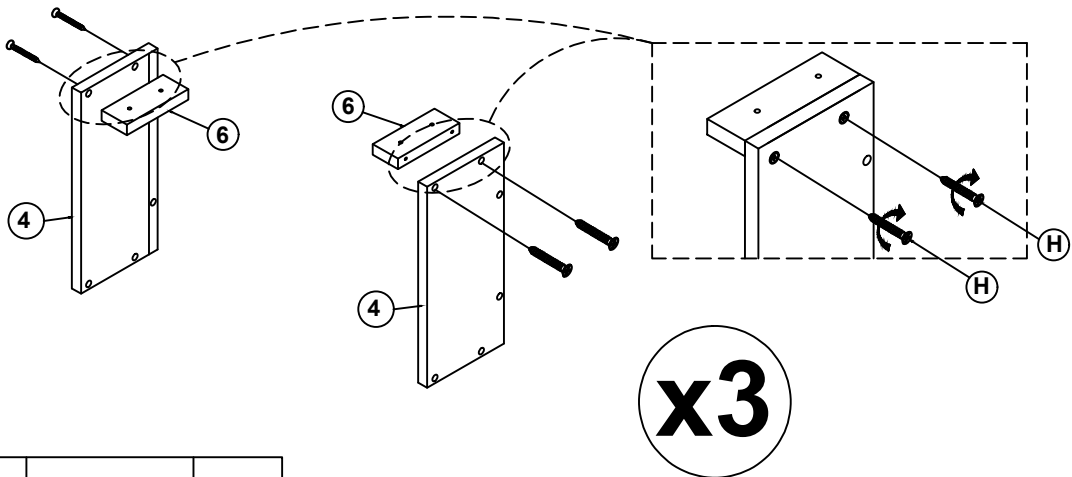

x3

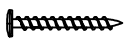
H	Flat Head Screw (m4x38mm-RBW)		12pcs
---	----------------------------------	-----------------------------------------------------------------------------------	-------

STEP 9

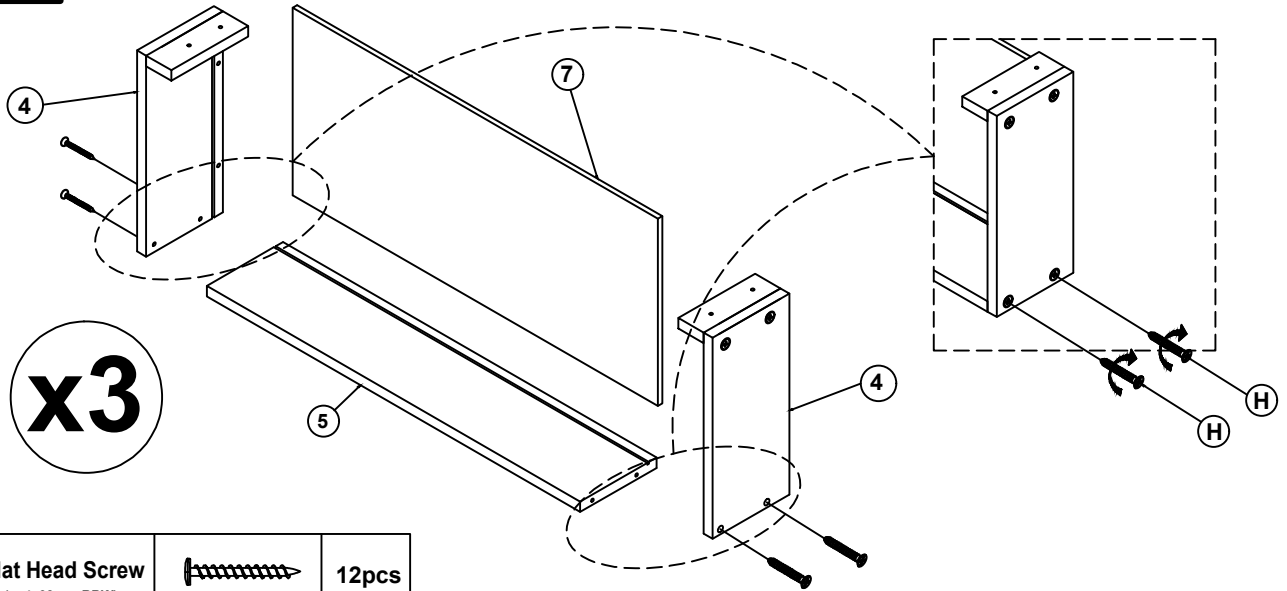

x3

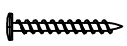
H	Flat Head Screw (m4x38mm-RBW)		12pcs
---	----------------------------------	-------------------------------------------------------------------------------------	-------

STEP 10

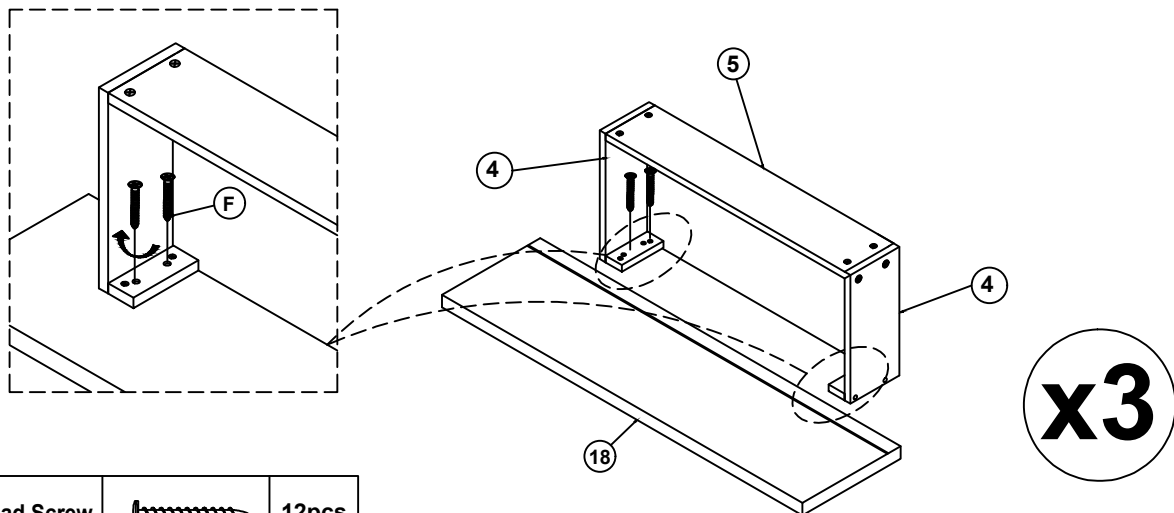

x3

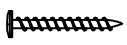
F	Flat Head Screw (m4x30mm-RBW)		12pcs
---	----------------------------------	-------------------------------------------------------------------------------------	-------

ASSEMBLY INSTRUCTIONS

STEP 11

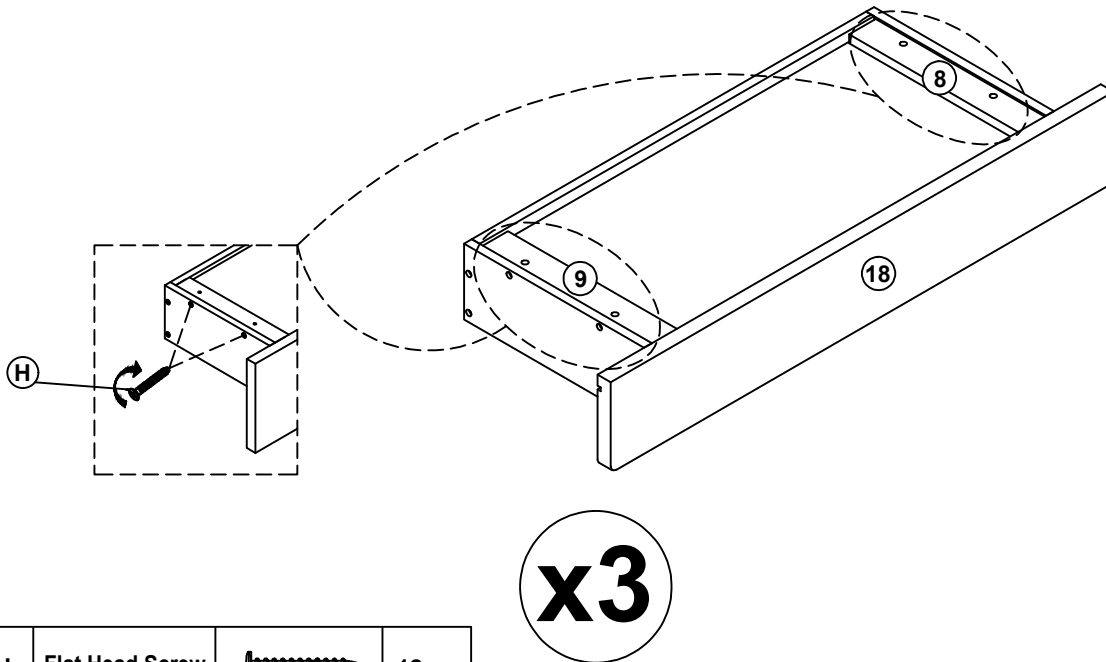

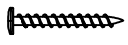
H	Flat Head Screw (m4x38mm-RBW)		12pcs
---	----------------------------------	-------------------------------------------------------------------------------------	-------

STEP 12

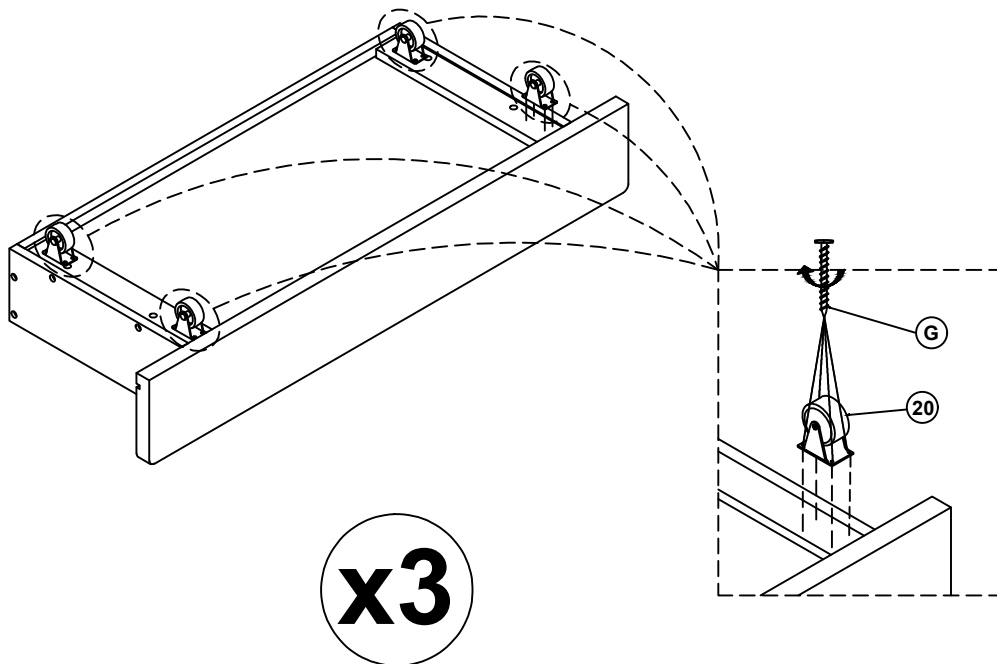

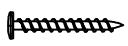

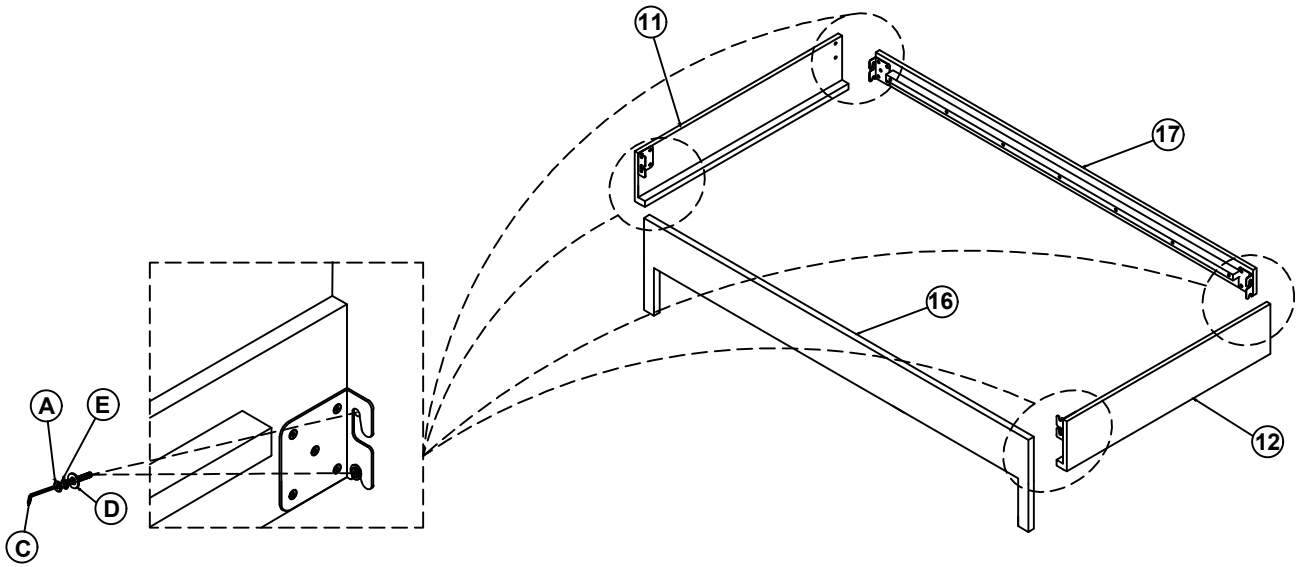

G	Flat Head Screw (m4x20mm-RBW)		48pcs
---	----------------------------------	-------------------------------------------------------------------------------------	-------

ASSEMBLY INSTRUCTIONS

STEP 13



A	Bolt (Ø 5/16 "X20mm)		8pcs	D	Flat Washer (Ø 5/16 "-RBW)		8pcs
E	Spring Washer (Ø 5/16 "-RBW)		8pcs	C	Allen Wrench (M4x75mm x32mm)		1pc

STEP 14

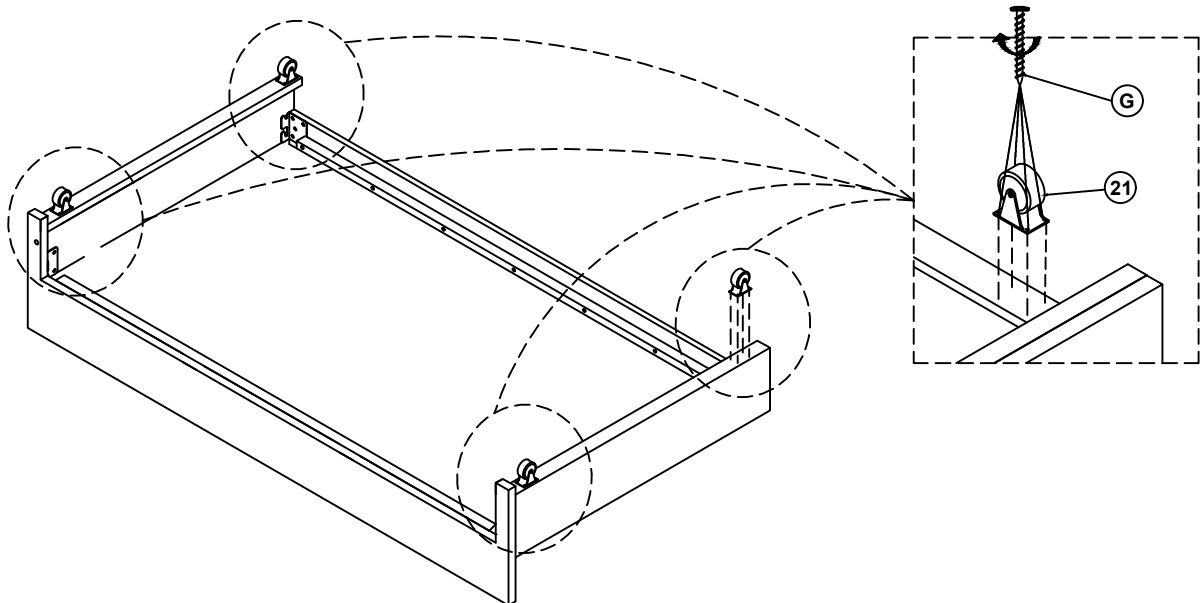

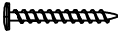
G	Flat Head Screw (m4x20mm-RBW)		16pcs
---	-----------------------------------------	-------------------------------------------------------------------------------------	-------

ASSEMBLY INSTRUCTIONS

STEP 15

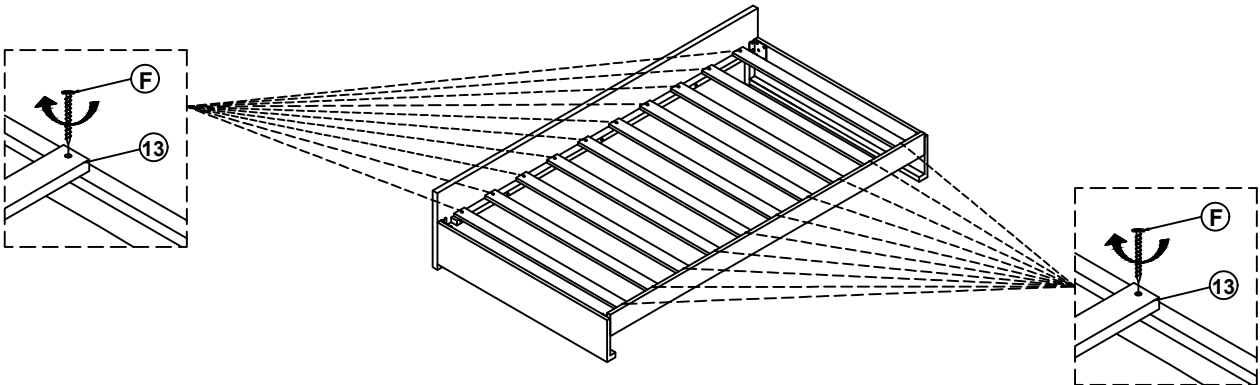

NOTE: Do not lock the screws of the trundle slats to the utermost edge the trundle slats,you need to leave a certain space at the edges, otherwise it will cause the board to break.

F Flat Head Screw
(m4x30mm-RBW)

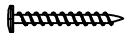

20pcs

STEP 16

COMPLETE

