

ASSEMBLY INSTRUCTIONS

ITEM CODE: WF307994 - WF307995

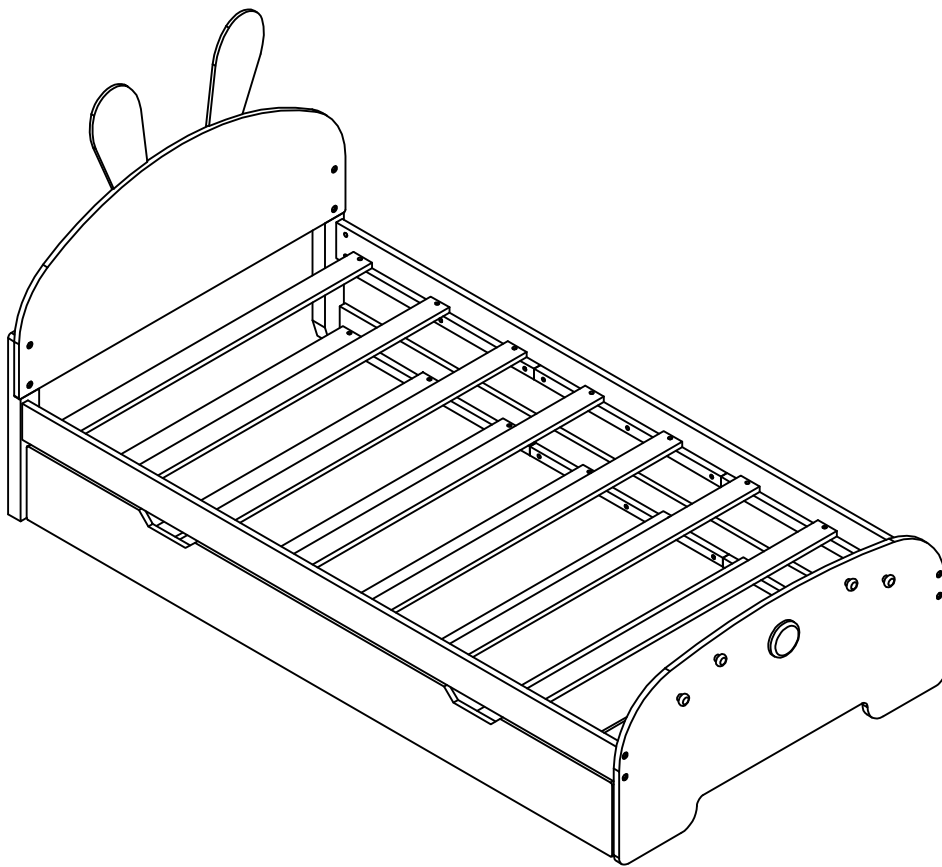

DETAIL VIEW

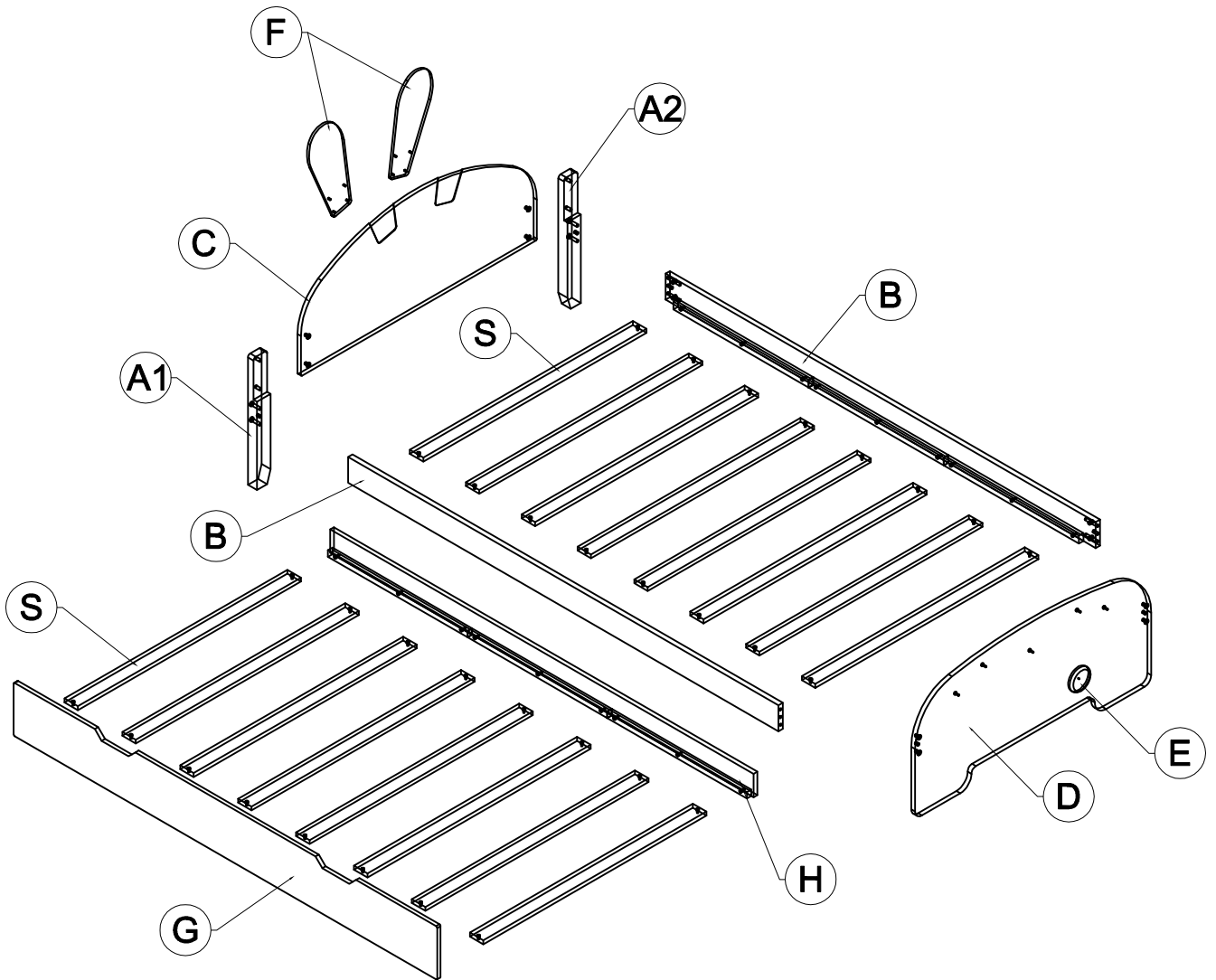

BOX 1: WF307994

A1



Front leg - left (1pc)

A2



Back leg - left (1pc)

B

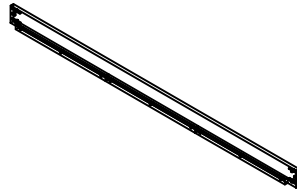

Side rail - left & right (2pcs)

G

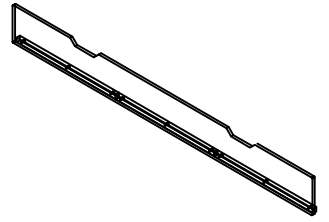

Extra Side rail - left (1pc)

H

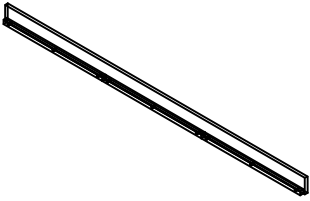

Extra Side rail - right (1pc)

BOX 2: WF307995

C

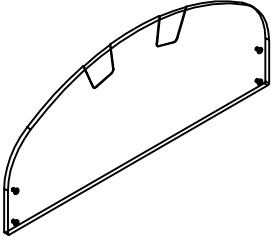

Headboard panel (1pc)

D

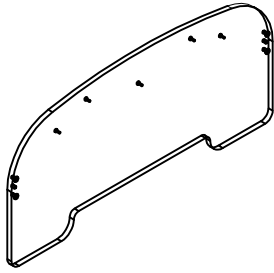

Footboard panel (1pc)

E

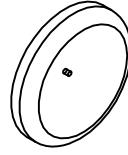

Babbit tail (1pcs)

F

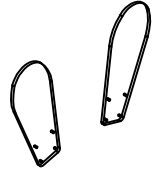





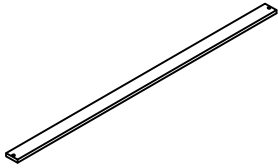

Bunny ear (2pcs)

S

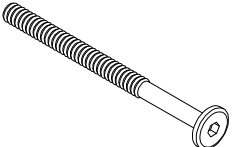
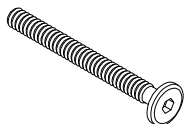

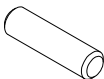
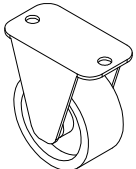
Slats (16pcs)

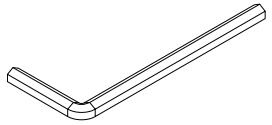
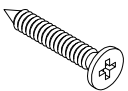
HARDWARE LIST: WF307994

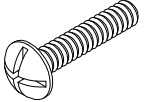
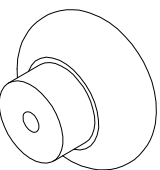
<p>1</p>  <p>Hex - Head bolts Ø1/4" * 80 - 4pcs</p>	<p>2</p>  <p>Hex - Head bolts Ø1/4" * 60 - 4pcs</p>	<p>3</p>  <p>Hex - Head bolts Ø1/4" * 25 - 4pcs</p>	<p>4</p>  <p>Horizontal - Hold bolts Ø1/4" - 8pcs</p>
<p>5</p>  <p>Wood dowel Ø8 * 30 - 4pcs</p>	<p>6</p>  <p>tow wheel - 4pcs</p>	<p>7</p>  <p>L - Bracket - 4pcs</p>	<p>8</p>  <p>Allen key K4 - 1pc</p>
<p>9</p>  <p>Wood crews M4 * 25 - 33pcs</p>	<p>10</p>  <p>Wood crews M3.5 * 15 - 16pcs</p>	<p>11</p>  <p>Wood crews M3.5 * 20 - 8pcs</p>	<p>12</p>  <p>Round crews Ø5/32" * 22 - 4pcs</p>
<p>13</p>  <p>Handle - 4pcs</p>			

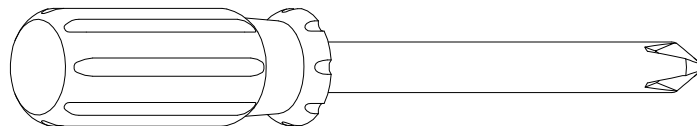

Assembly Tools Required (Not Included)

STEP 1

11



Wood crews
M3.5 * 20 - 8pcs

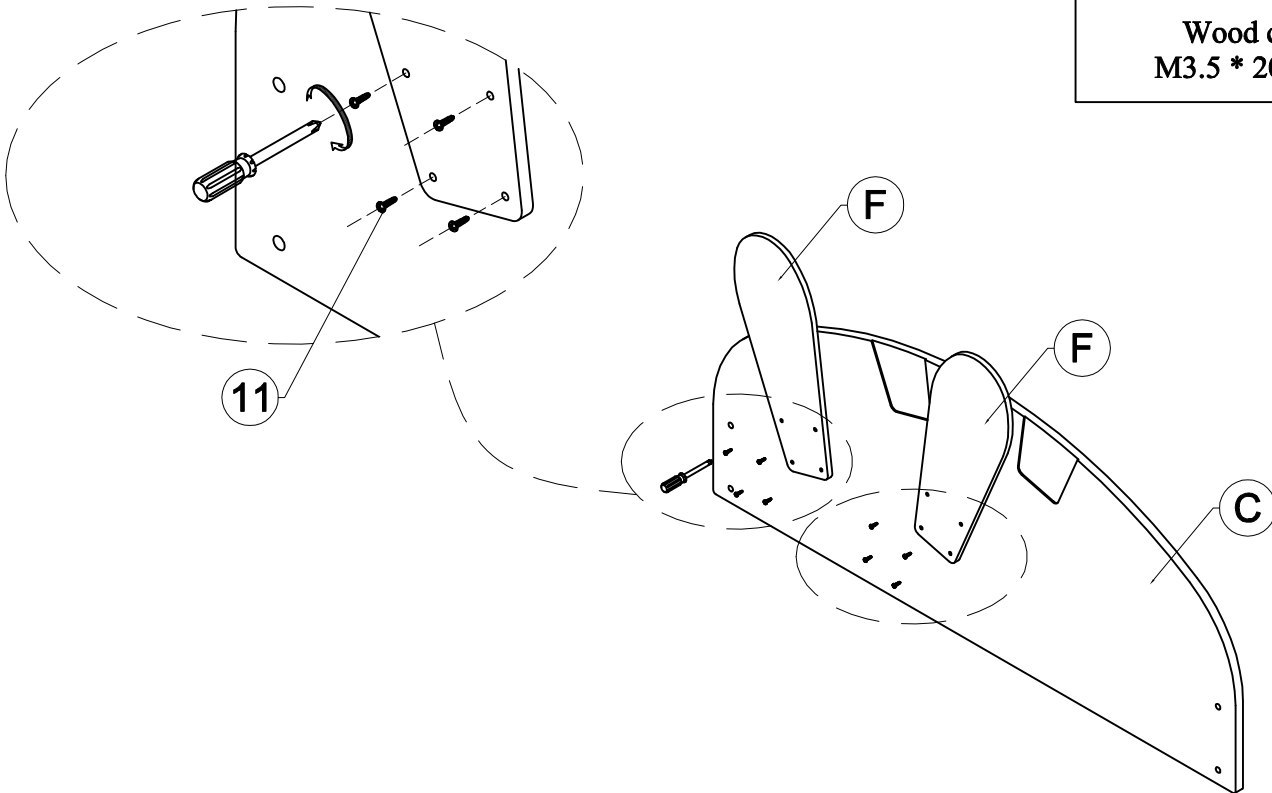

STEP 2

9

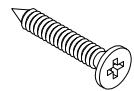

Wood crews
M4 * 25 - 1pc

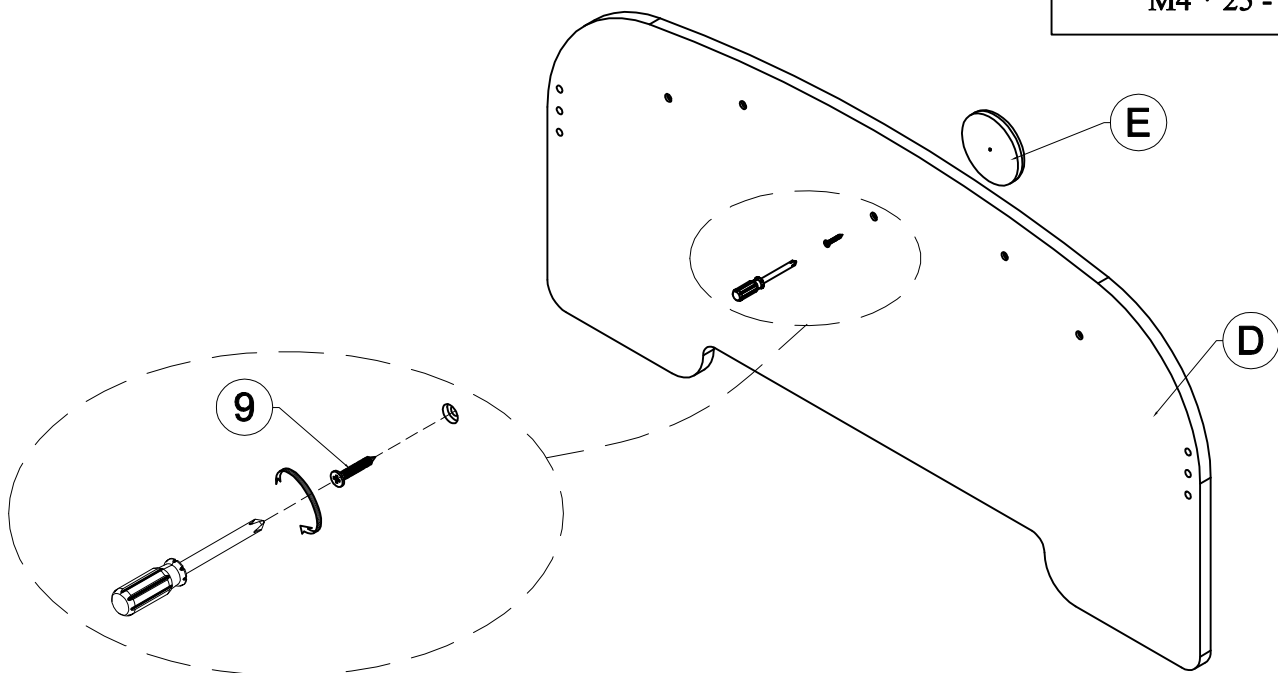

STEP 3

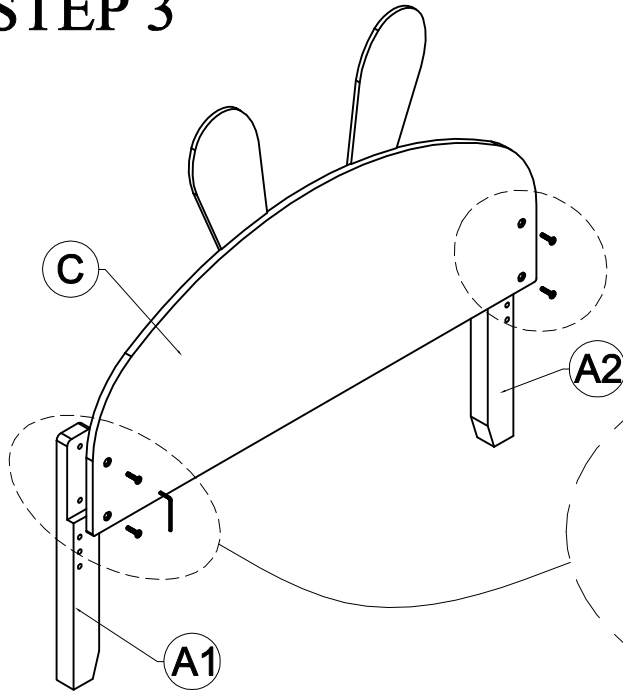



3

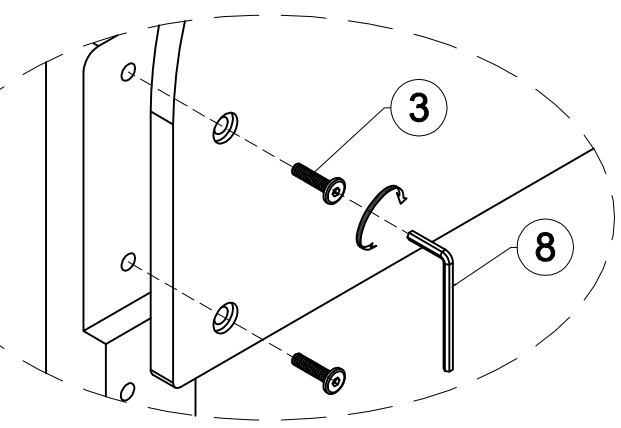

Hex - Head bolts
Ø1/4" * 25 - 4pcs

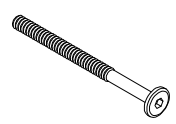
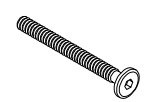

STEP 4

<p>1</p>  <p>Hex - Head bolts Ø1/4" * 80 - 4pcs</p>	<p>2</p>  <p>Hex - Head bolts Ø1/4" * 60 - 4pcs</p>	<p>4</p>  <p>Horizontal - Hold bolts Ø1/4" - 8pcs</p>	<p>5</p>  <p>Wood dowel Ø8 * 30 - 4pcs</p>
---	---	--	---

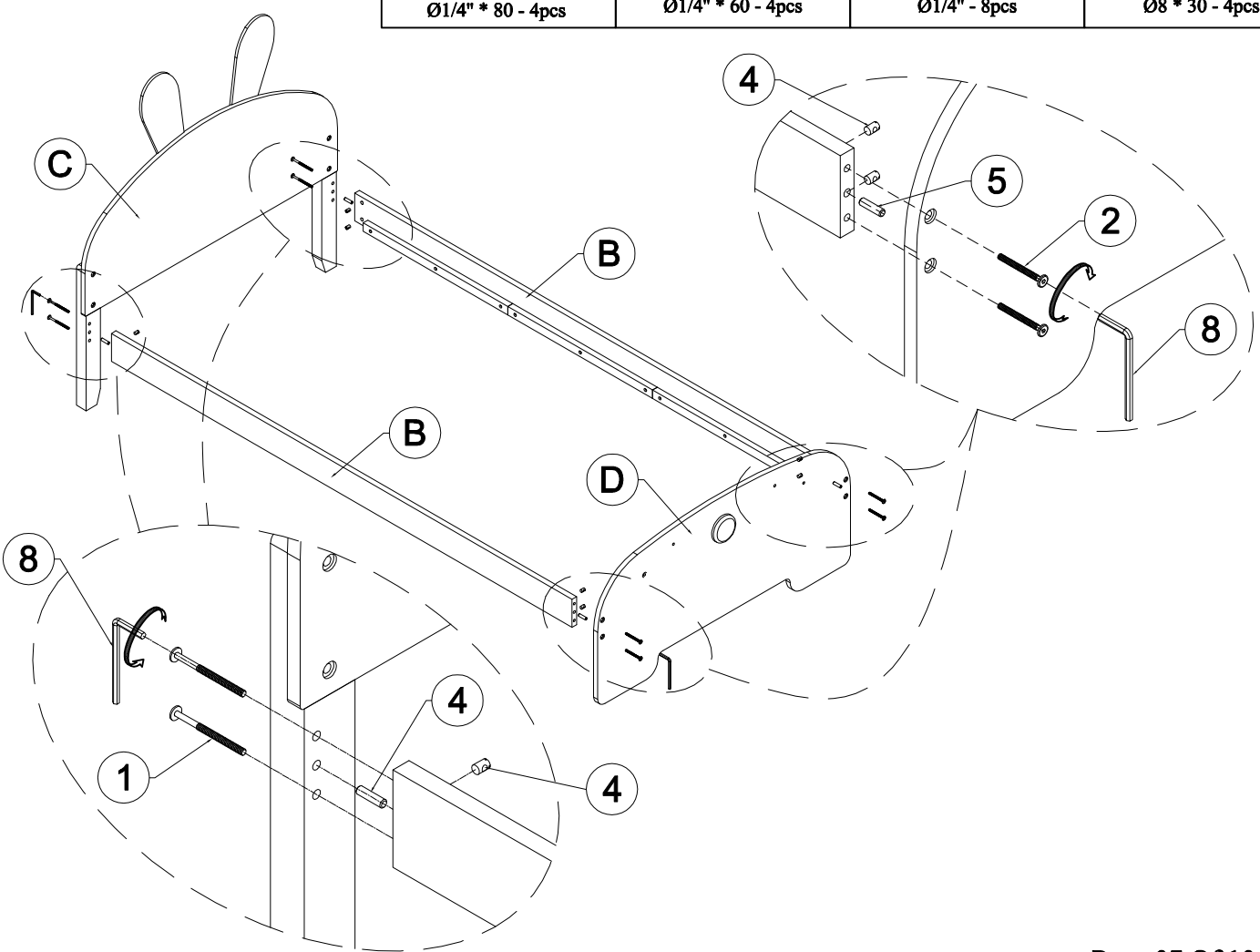

STEP 5

The distance between the slats is 7.4 inch

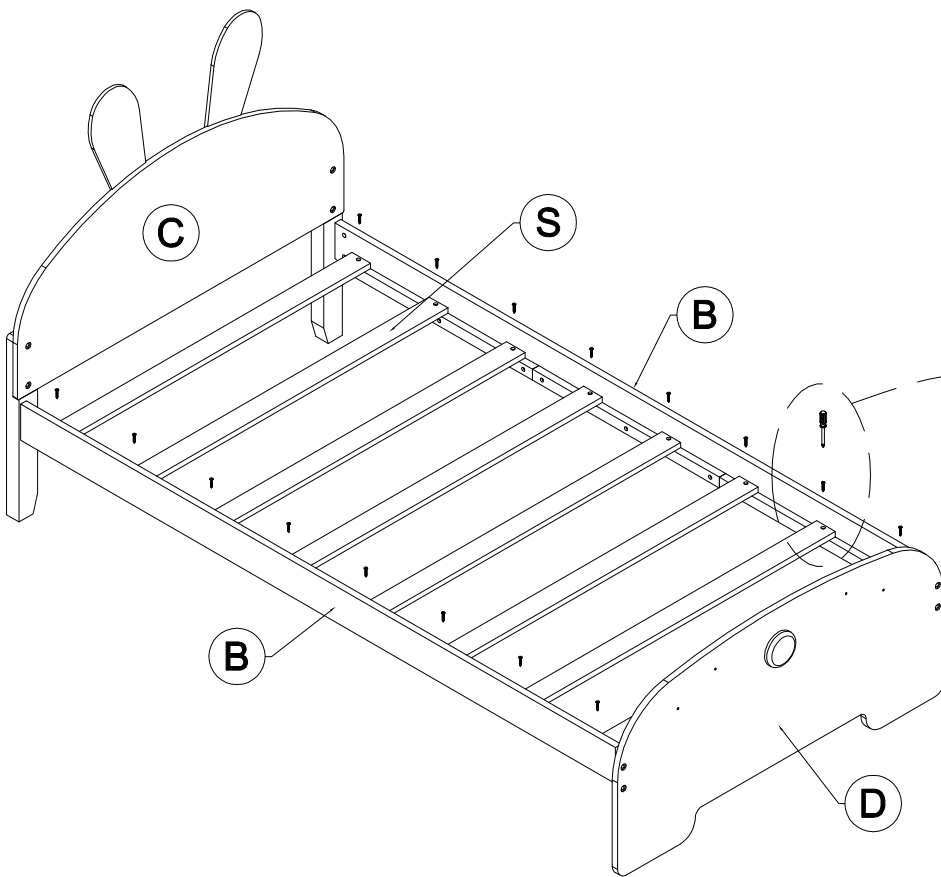

9

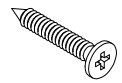

Wood crews
M4 * 25 - 16pcs

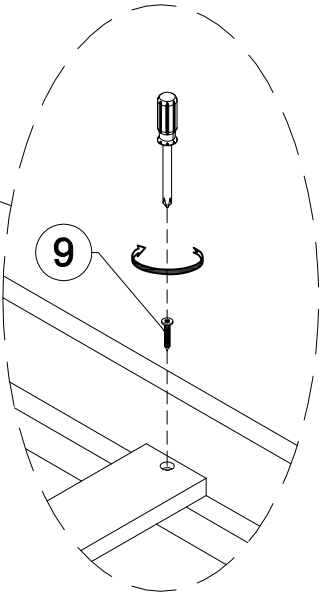

STEP 6

The distance between the slats is 7.75 inch

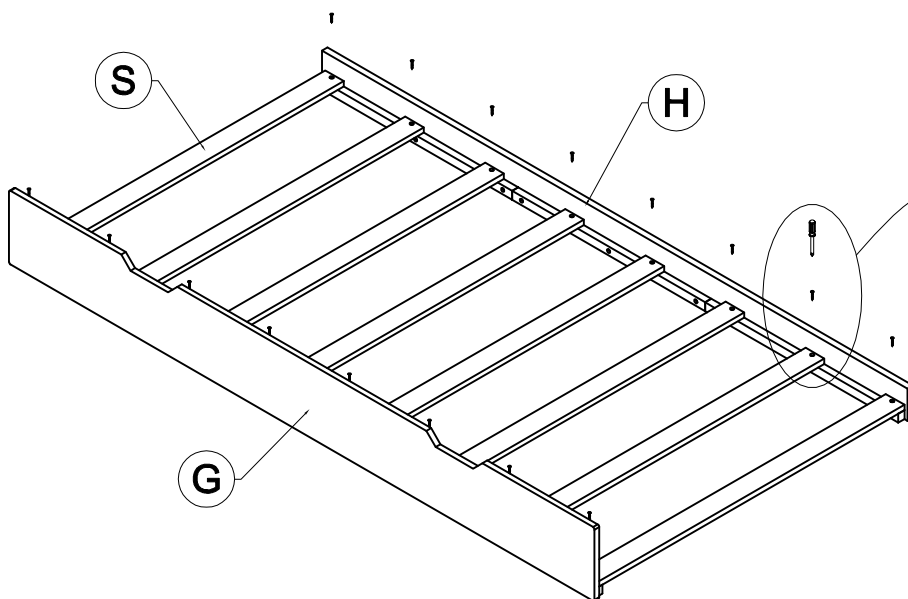

9

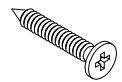

Wood crews
M4 * 25 - 16pcs

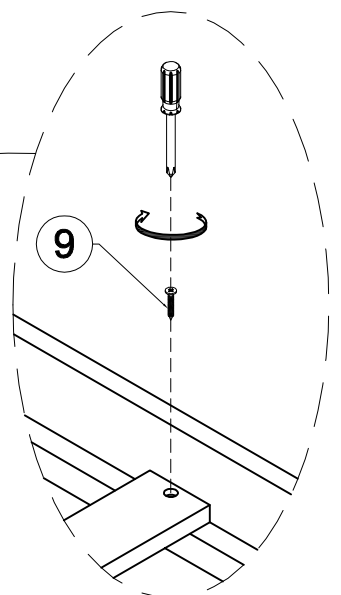

STEP 7

7



L - Bracket - 4pcs

10



Wood crews
M3.5 * 15 - 8pcs

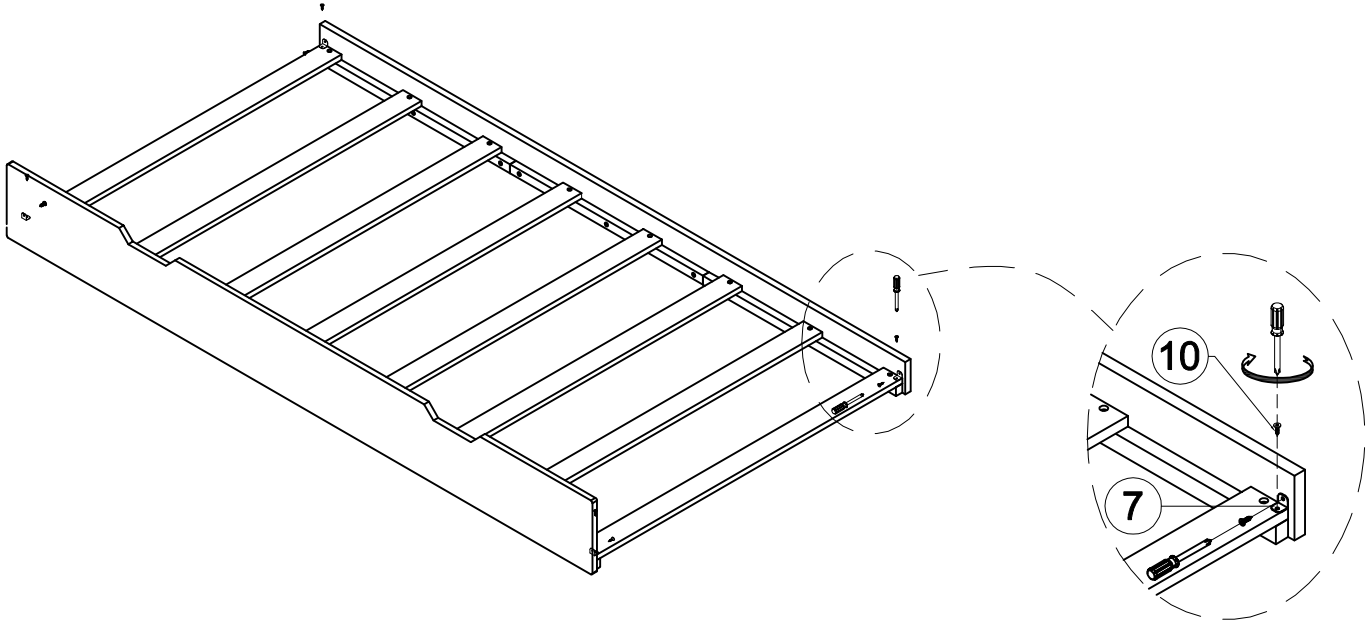

STEP 8

6

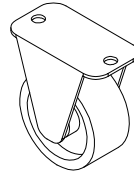

tow wheel - 4pcs

10



Wood crews
M3.5 * 15 - 8pcs

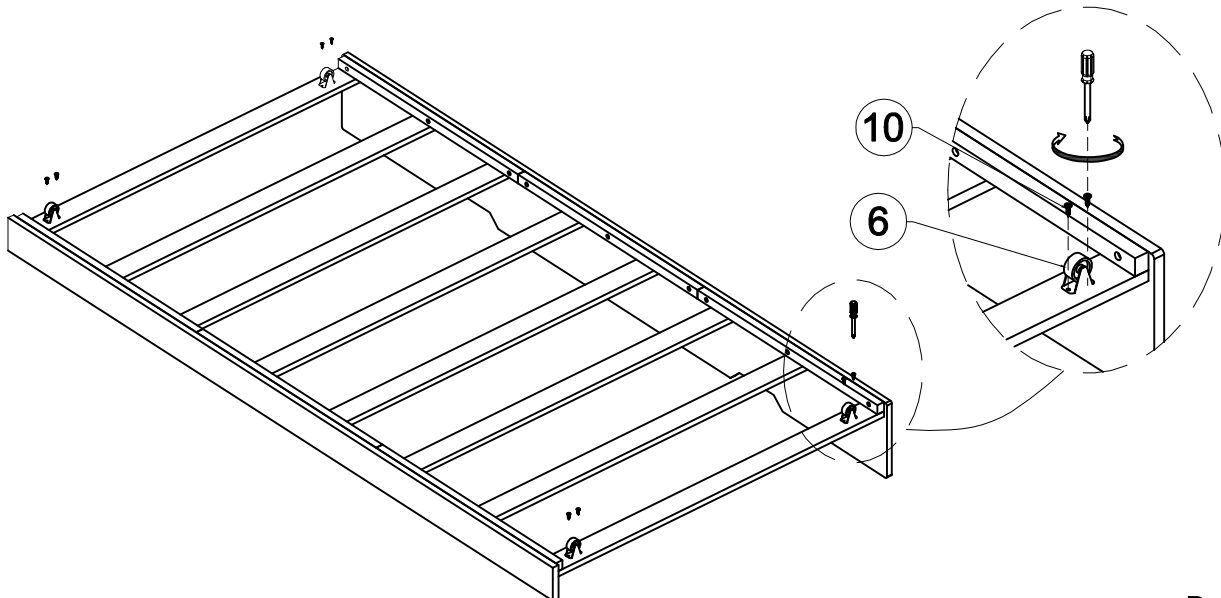

STEP 9

12

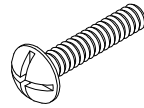

Round crews
Ø5/32" * 22 - 4pcs

13

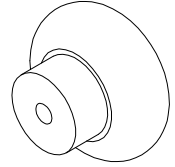

Handle - 4pcs

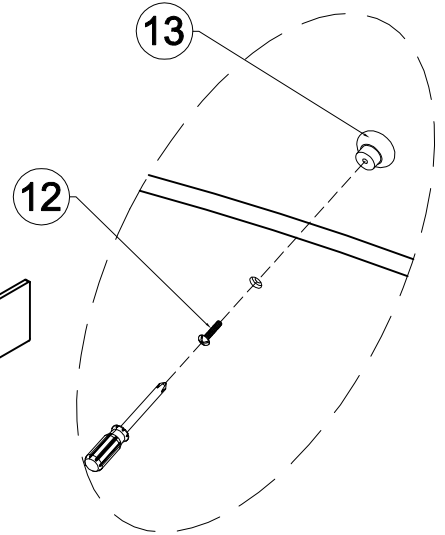
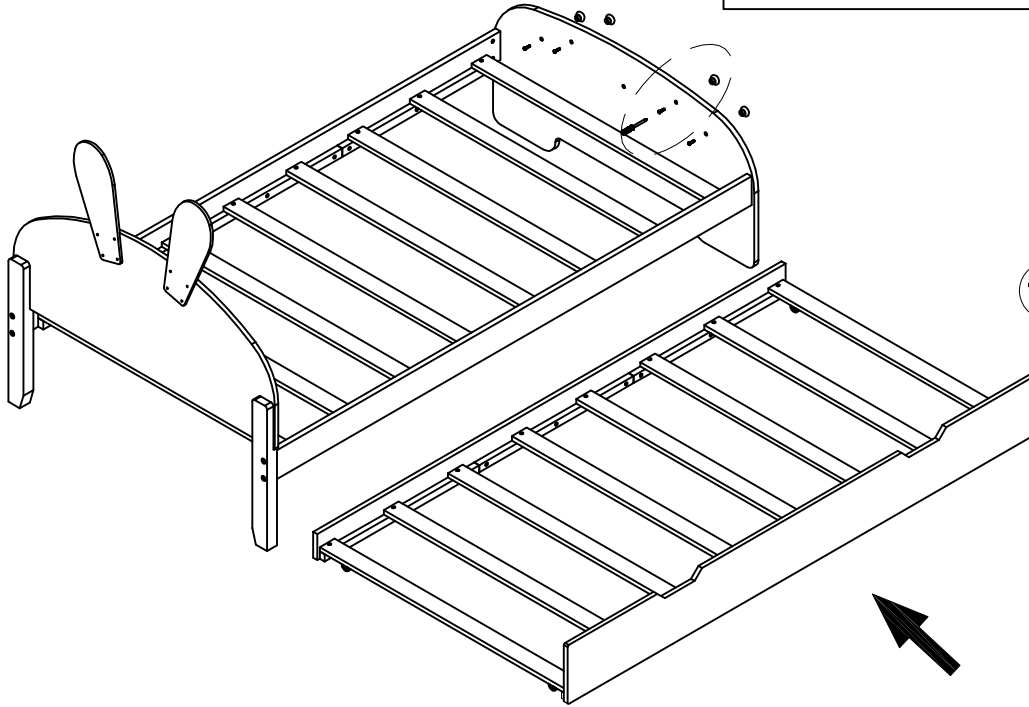

COMPLETED

