

ASSEMBLY INSTRUCTION

SKU CODE: (WF 308379 - WF 308380)

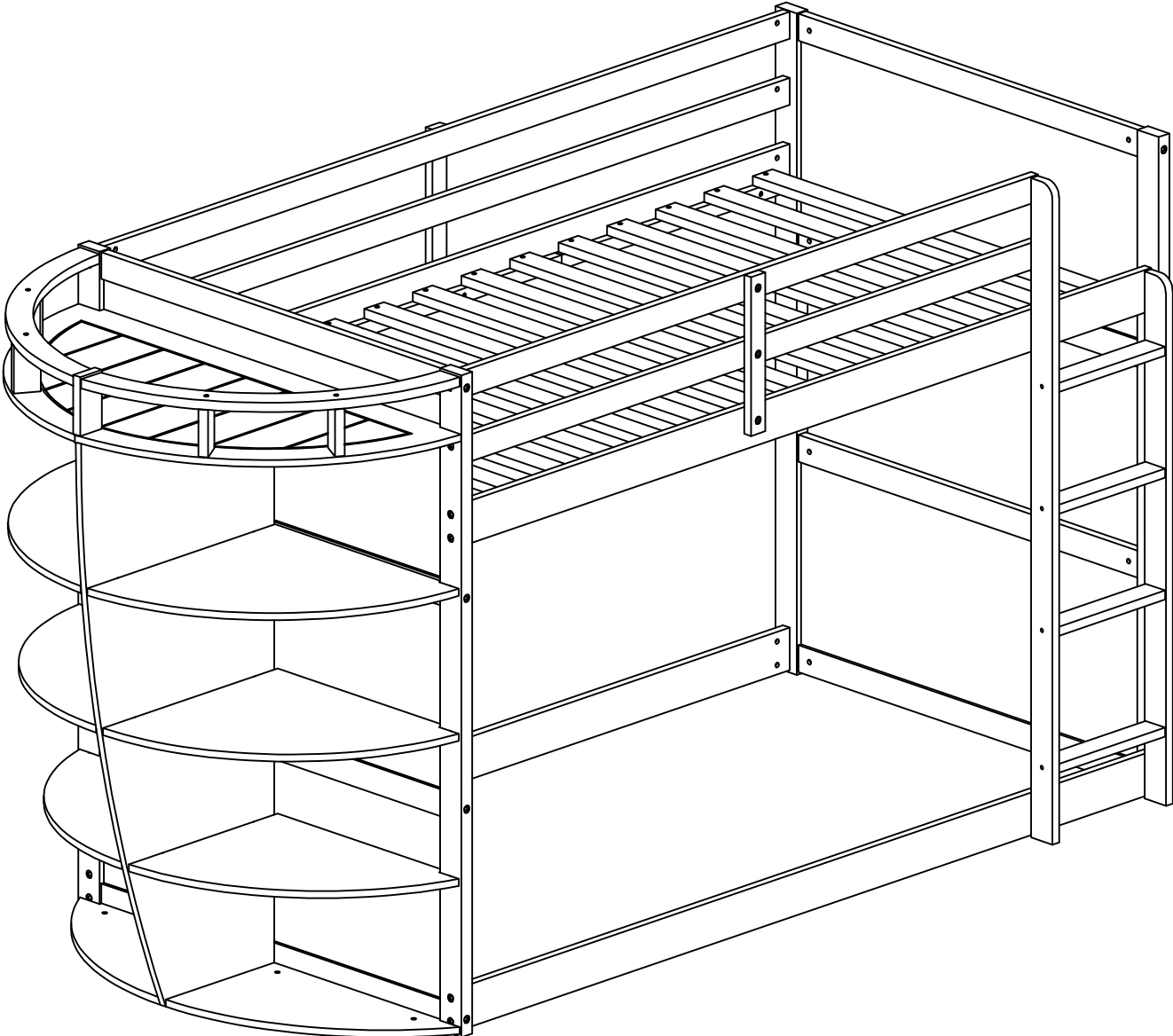

! SAFETY WARNINGS !

1. This bed is designed for use only mattress (es) meeting the following specifications on the upper bunk, and lower bunk

Upper bed

Bed Type	Length	Width	Thickness
<i>Twin Standard</i>	<i>74" - 75"</i>	<i>38 1/2"</i>	<i>6" max</i>

Lower bed

Bed Type	Length	Width	Thickness
<i>Twin Standard</i>	<i>74" - 75"</i>	<i>38 1/2"</i>	<i>8" max</i>

2. Replacement parts, including additional guardrails, maybe obtained from any of our (GIGACLOUD TECHNOLOGY (USA) INC. 18961 ARENTH AVENUE CITY OF INDUSTRY, CA, 91748) dealers
3. Follow the information on the warnings appearing on the upper bunk bed end structure and on the carton. Do not remove warning label from bed
4. Always use the recommended size mattresses or mattress supports, or both, to help prevent the likelihood of entrapment or falls.
5. Surface of mattress must be at least 5" (127mm) below the upper edge of guardrails
6. Do not allow children under 6 years of age to use the upper bunk.
7. Periodically check and ensure that the guardrail, ladder, and other components are in their proper position, free from damage, and that all connectors are tight.
8. Do not allow horseplay on or under the bed and prohibit jumping on the bed.
9. Always use the ladder for entering and leaving the upper bunk.
10. Do not use substitute part. Contact the manufacture or dealer for replacement part
11. Use of a night light may provide added safety precaution for a child using the upper bunk..
12. Always use guardrails on both long sides of the upper bunk. If the bunk bed will be placed next to the wall, the guardrail that runs the full length of the bed should be placed against the wall to prevent entrapment between the bed and wall.
13. The use of water or sleep flotation mattresses is prohibited
14. **STRANGULATION HAZARD** - Never attach or hang items to any part of the bunk bed that are not designed for use with the bed; for example, but not limited to, hook, belts and jump ropes
15. Keep these instruction for future reference
16. Prohibit more than one person on upper bunk
17. We recommend assembling your bunk bed on the shipping carton to protect your floor or carpet
18. Be certain all staples are out of the box before beginning assembly on the shipping carton.

ASSEMBLY INSTRUCTION

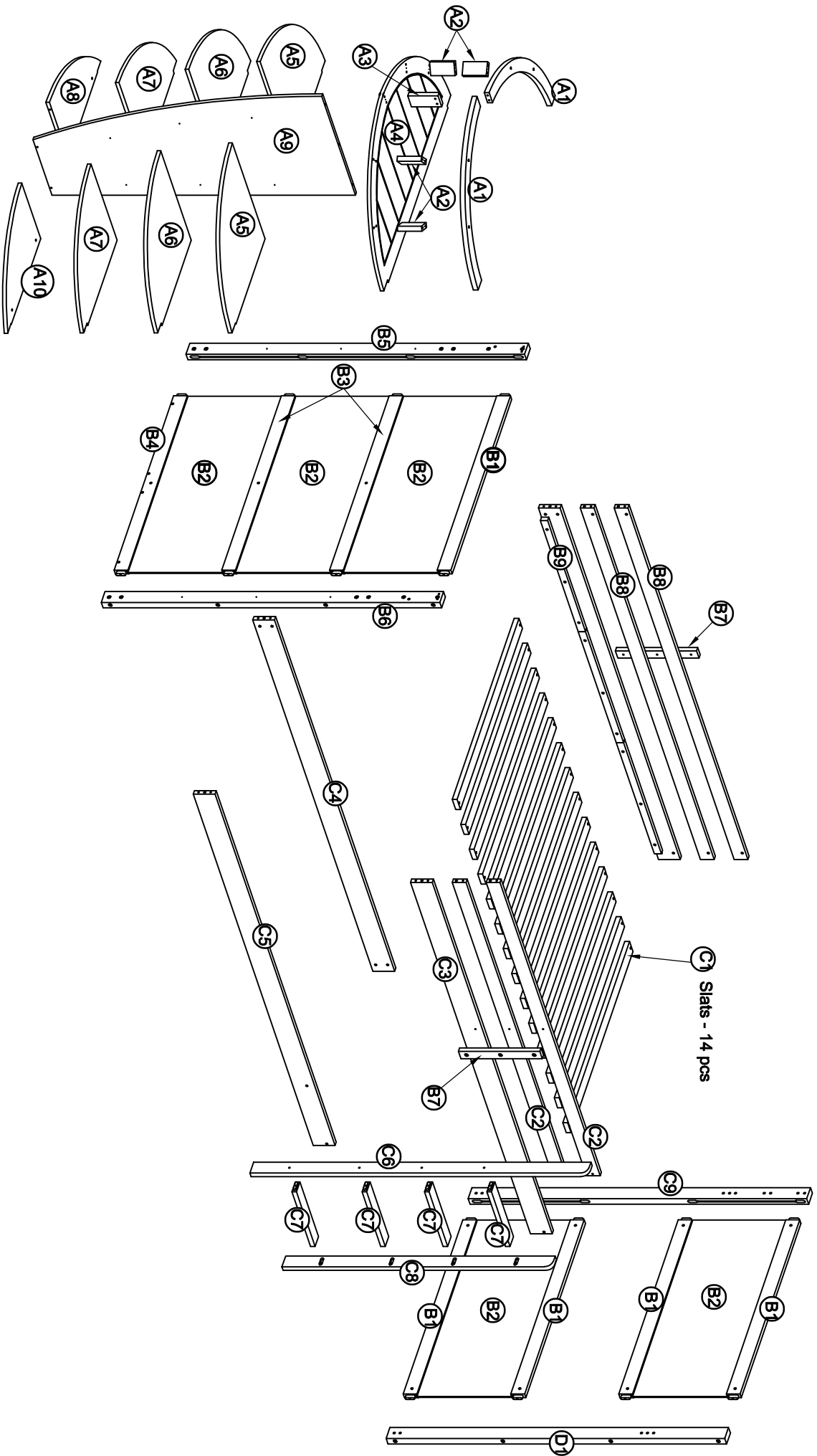

Part List (Box1-WF 308379)

A1

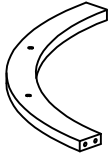

Wood Bar - 02 pcs

A4

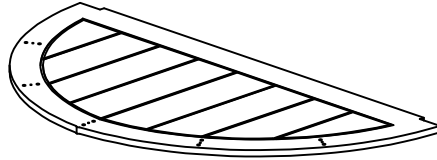

Shelf - 01 pc

A5



Shelf - 02 pcs

A6



Shelf - 02 pcs

A7



Shelf - 02 pcs

A8

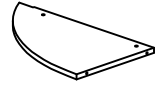

Shelf - 01 pc

A9



Partition - 01 pc

A10







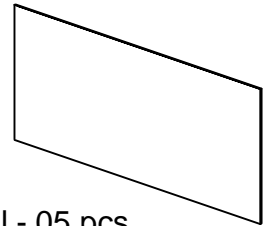





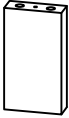

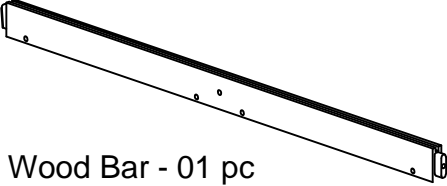

Shelf - 01 pc

B2

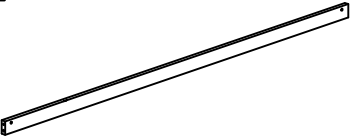
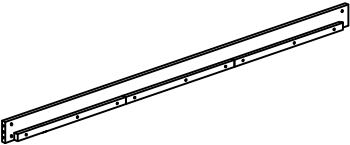
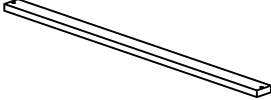
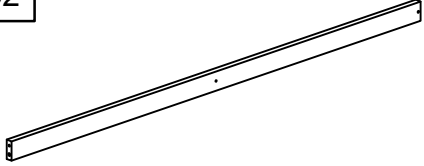
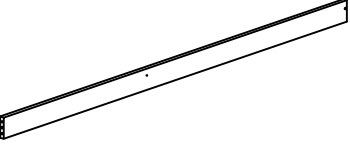
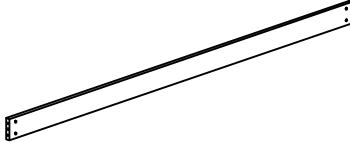
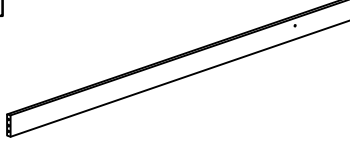

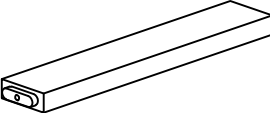





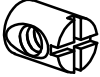
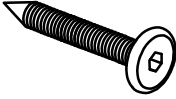

Panel - 05 pcs

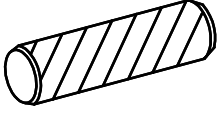
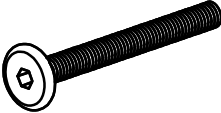
Part List & Hardware List(Box2-WF 308380)

<p>A2</p>  <p>Wood bar - 04 pcs</p>	<p>A3</p>  <p>Wood Bar - 1 pc</p>	<p>B1</p>  <p>Wood bar - 05 pcs</p>
<p>B3</p>  <p>Wood Bar - 02 pcs</p>	<p>B4</p>  <p>Wood Bar - 01 pc</p>	<p>B5</p>  <p>Leg - 01 pc</p>
<p>B6</p>  <p>Leg - 01 pc</p>	<p>B7</p>  <p>Wood Bar - 02 pcs</p>	<p>B8</p>  <p>Wood Bar - 04 pcs</p>
<p>B9</p>  <p>Side rail - 01 pc</p>	<p>C1</p>  <p>Slats - 14 pcs</p>	<p>C2</p>  <p>Wood Bar - 02 pcs</p>
<p>C3</p>  <p>Side rail - 01 pc</p>	<p>C4</p>  <p>Wood Bar - 01 pc</p>	<p>C5</p>  <p>Wood Bar - 01 pc</p>
<p>C6</p>  <p>Wood Bar - 01 pc</p>	<p>C7</p>  <p>Wood Bar - 04 pcs</p>	<p>C8</p>  <p>Wood Bar - 01 pc</p>
<p>C9</p>  <p>Wood Bar - 01 pc</p>	<p>D1</p>  <p>Wood Bar - 01 pc</p>	

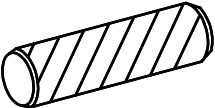

Hardware List(Box2 - WF 308380)

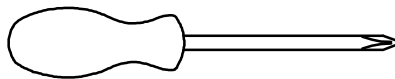
<div style="border: 1px solid black; padding: 2px; width: 20px; float: left; margin-right: 5px;">1</div> <div style="text-align: center; margin: 10px 0;">  </div> <p style="text-align: center;">Ø1/4" x 100 mm Hex-Head bolts 16 pcs</p>	<div style="border: 1px solid black; padding: 2px; width: 20px; float: left; margin-right: 5px;">2</div> <div style="text-align: center; margin: 10px 0;">  </div> <p style="text-align: center;">Ø1/4" x 11 mm Horizontal-Hole bolts 47 pcs</p>	<div style="border: 1px solid black; padding: 2px; width: 20px; float: left; margin-right: 5px;">3</div> <div style="text-align: center; margin: 10px 0;">  </div> <p style="text-align: center;">Screws 1/4" x30 6 pcs</p>
<div style="border: 1px solid black; padding: 2px; width: 20px; float: left; margin-right: 5px;">4</div> <div style="text-align: center; margin: 10px 0;">  </div> <p style="text-align: center;">Ø1/4" x 60 mm Hex-Head bolts 7 pcs</p>	<div style="border: 1px solid black; padding: 2px; width: 20px; float: left; margin-right: 5px;">5</div> <div style="text-align: center; margin: 10px 0;">  </div> <p style="text-align: center;">Screws 1/4" x40 14 pcs</p>	<div style="border: 1px solid black; padding: 2px; width: 20px; float: left; margin-right: 5px;">6</div> <div style="text-align: center; margin: 10px 0;">  </div> <p style="text-align: center;">Ø10 x 40 mm Wood dowel 14 pcs</p>
<div style="border: 1px solid black; padding: 2px; width: 20px; float: left; margin-right: 5px;">7</div> <div style="text-align: center; margin: 10px 0;">  </div> <p style="text-align: center;">Ø1/4" x 80 mm Hex-Head bolts 24 pcs</p>	<div style="border: 1px solid black; padding: 2px; width: 20px; float: left; margin-right: 5px;">8</div> <div style="text-align: center; margin: 10px 0;">  </div> <p style="text-align: center;">Screws M4 x30 37 pcs</p>	<div style="border: 1px solid black; padding: 2px; width: 20px; float: left; margin-right: 5px;">9</div> <div style="text-align: center; margin: 10px 0;">  </div> <p style="text-align: center;">Allen key 1 pc</p>
<div style="border: 1px solid black; padding: 2px; width: 20px; float: left; margin-right: 5px;">10</div> <div style="text-align: center; margin: 10px 0;">  </div> <p style="text-align: center;">Screws M3.5 x12 32 pcs</p>	<div style="border: 1px solid black; padding: 2px; width: 20px; float: left; margin-right: 5px;">11</div> <div style="text-align: center; margin: 10px 0;">  </div> <p style="text-align: center;">Bracket 7 pcs</p>	<div style="border: 1px solid black; padding: 2px; width: 20px; float: left; margin-right: 5px;">12</div> <div style="text-align: center; margin: 10px 0;">  </div> <p style="text-align: center;">Bracket 18 pcs</p>
<div style="border: 1px solid black; padding: 2px; width: 20px; float: left; margin-right: 5px;">13</div> <div style="text-align: center; margin: 10px 0;">  </div> <p style="text-align: center;">Ø8 x 30 mm Wood dowel 35 pcs</p>		





Assembly Tools Required (Not Included)

STEP 1: Following below illustration.

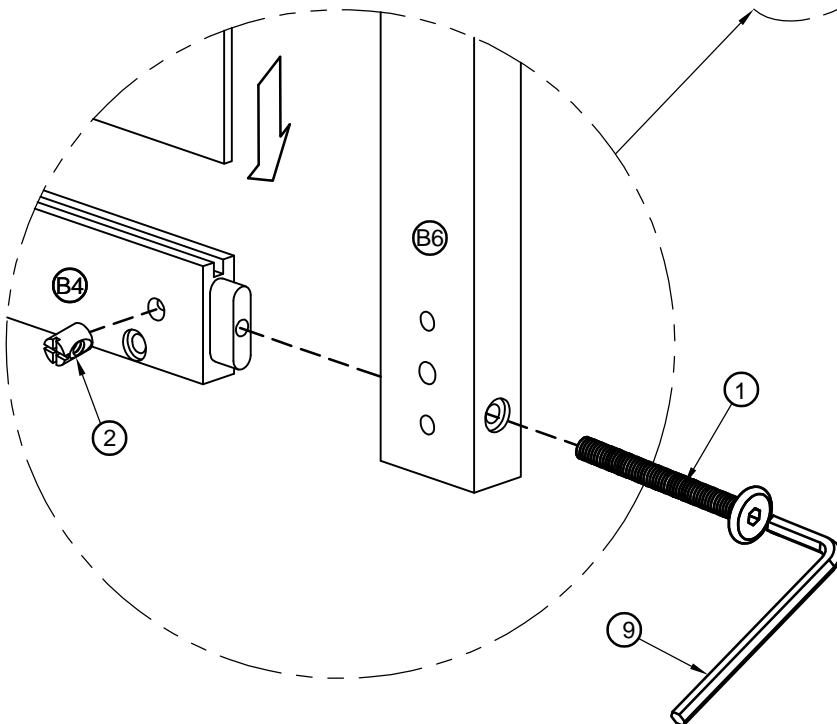
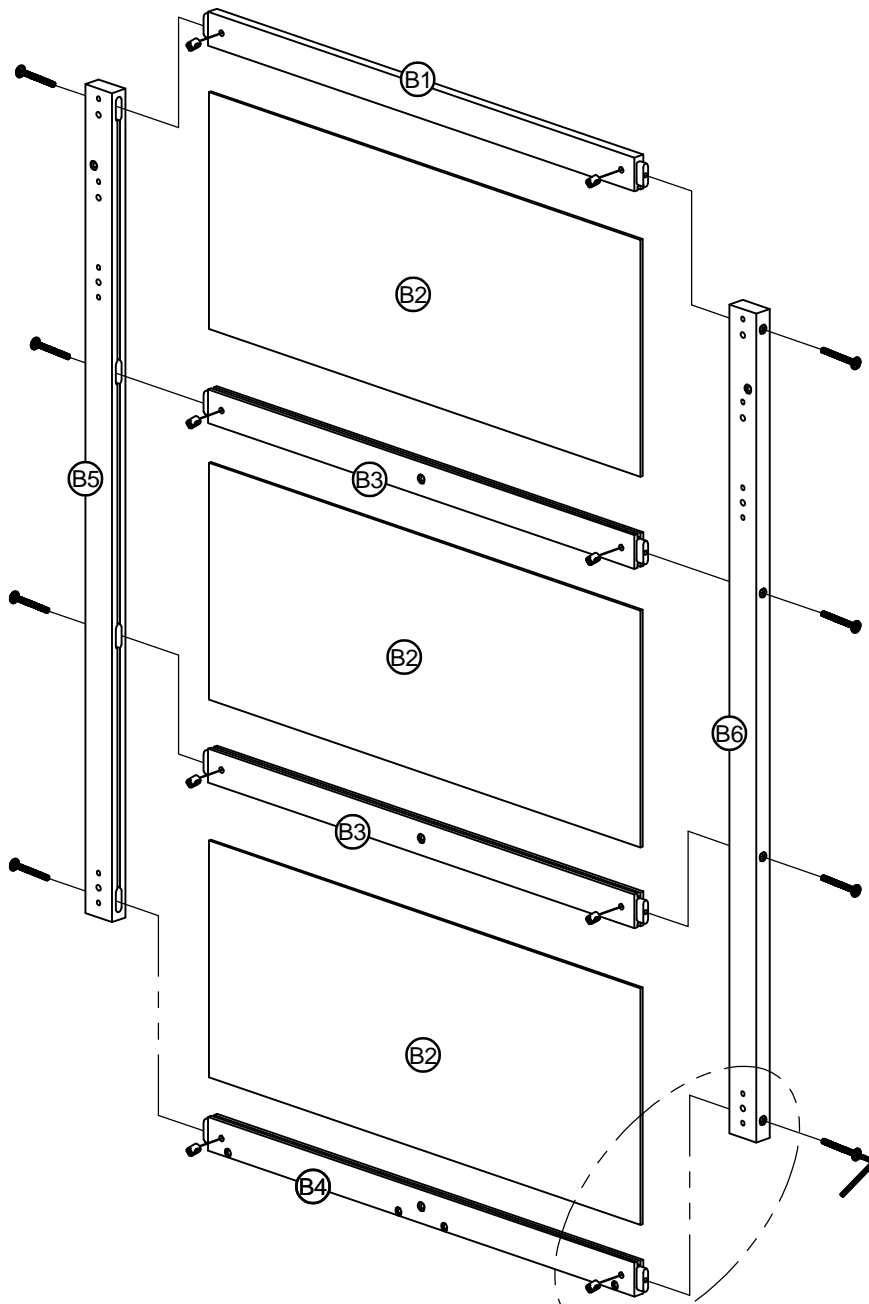
1	2
	
8(pcs)	8(pcs)





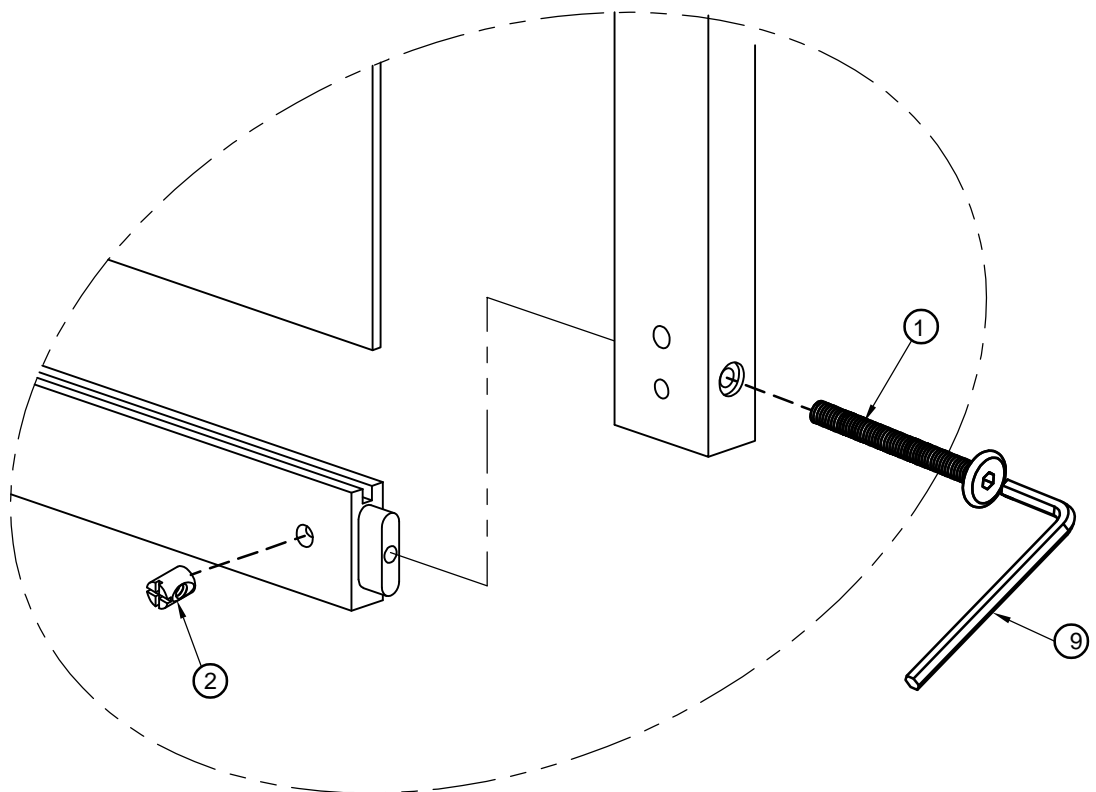
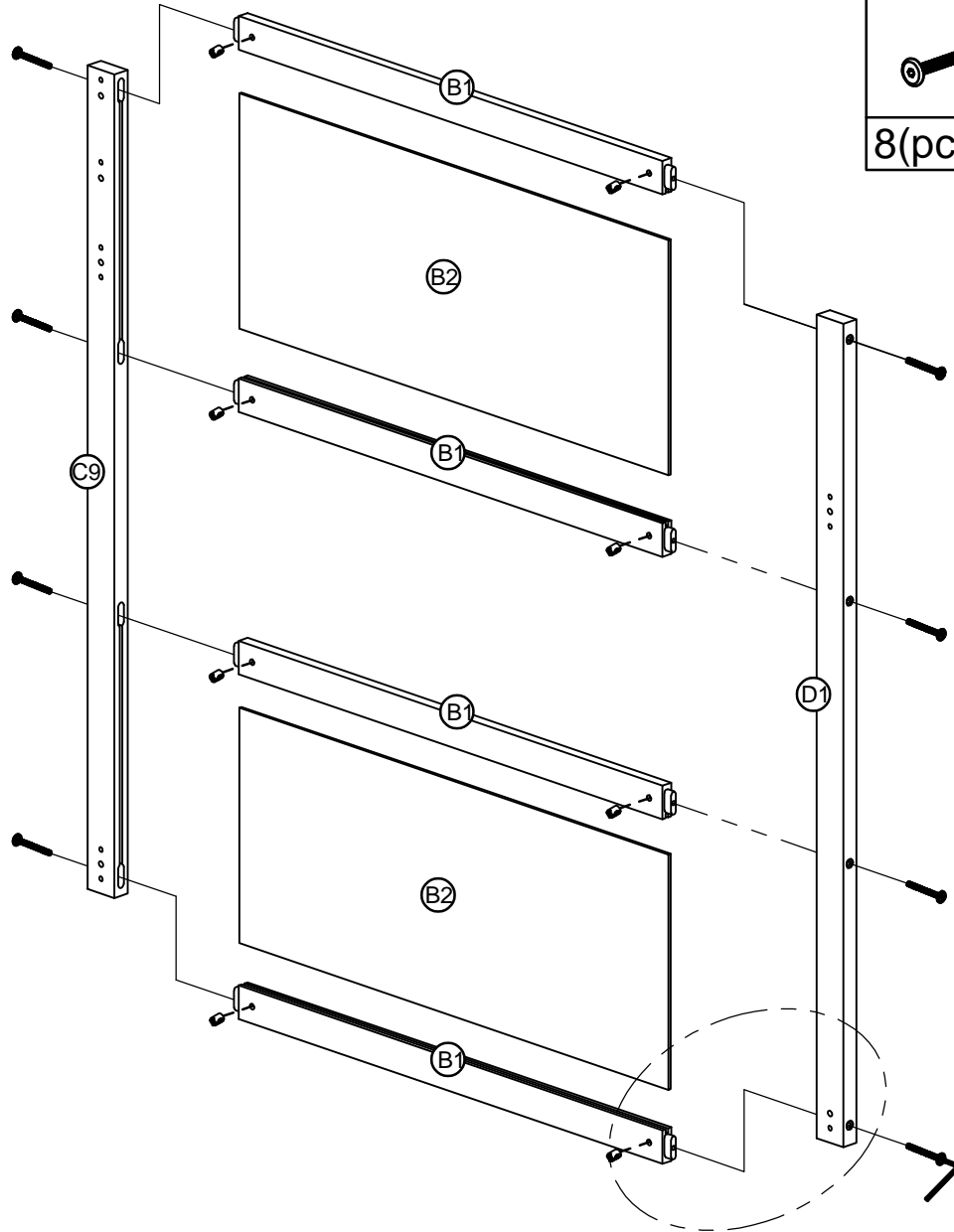

STEP 2: Following below illustration.

1	2
	
8(pcs)	8(pcs)

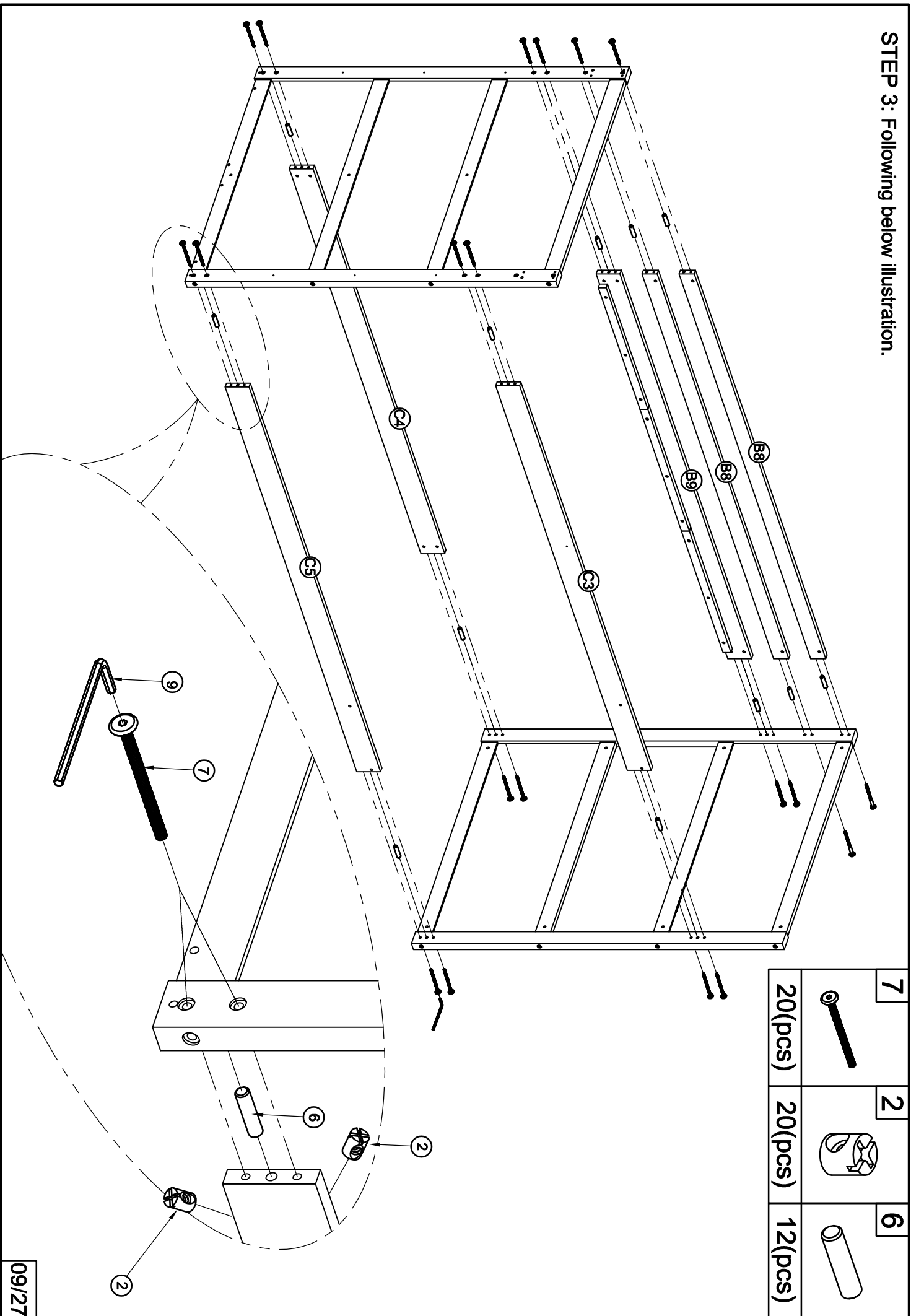



STEP 3: Following below illustration.

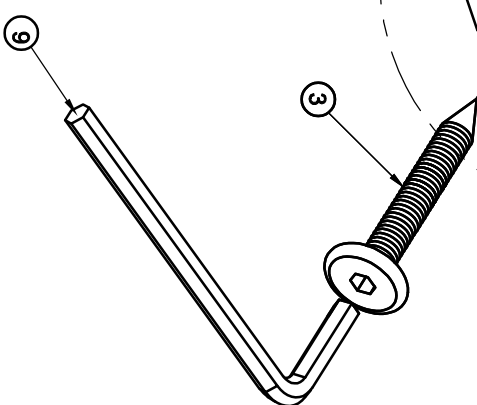
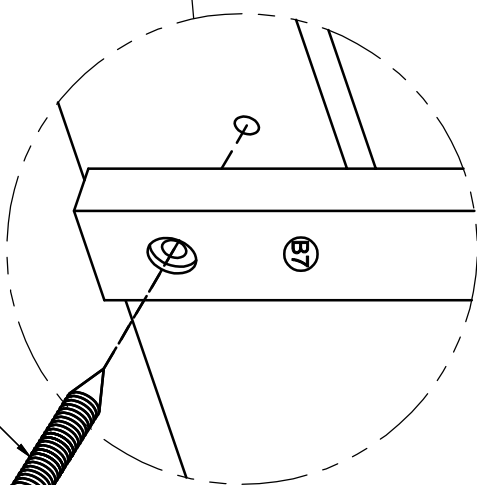
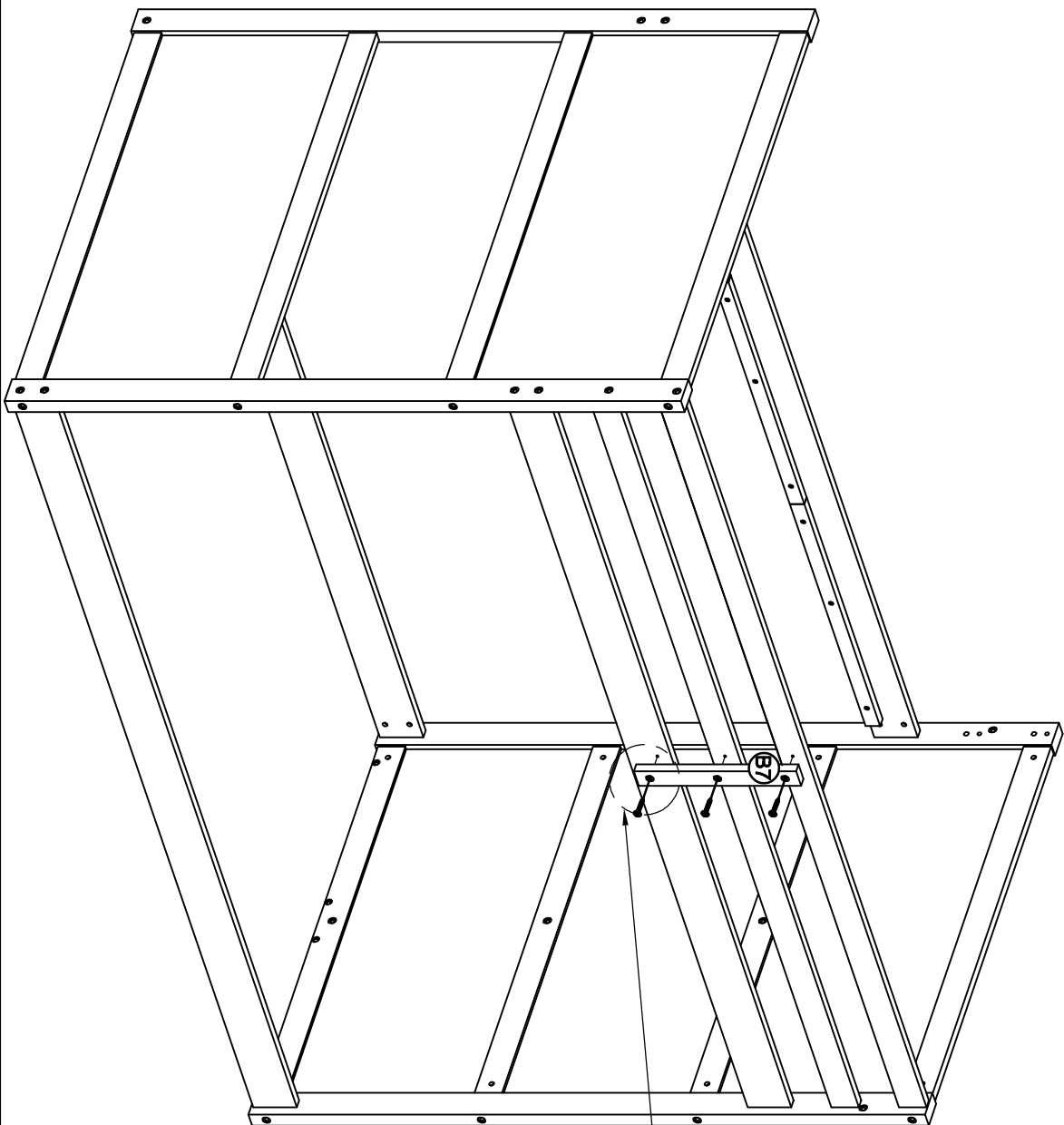

7		20(pcs)
2		20(pcs)
6		12(pcs)

STEP 4: Following below illustration.



3	
3 (pcs)	

STEP 5: Following below illustration.

5

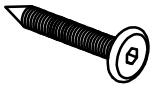

8 (pcs)

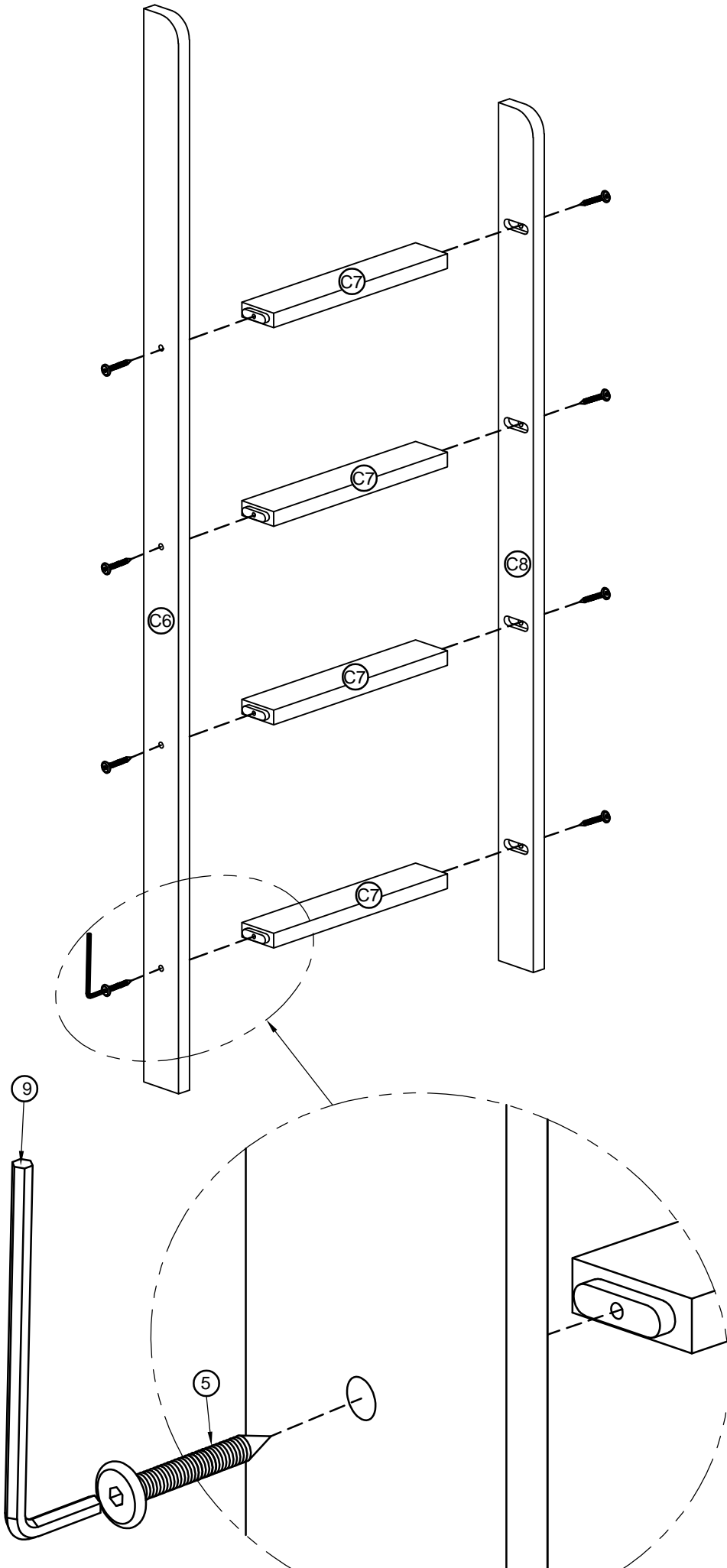



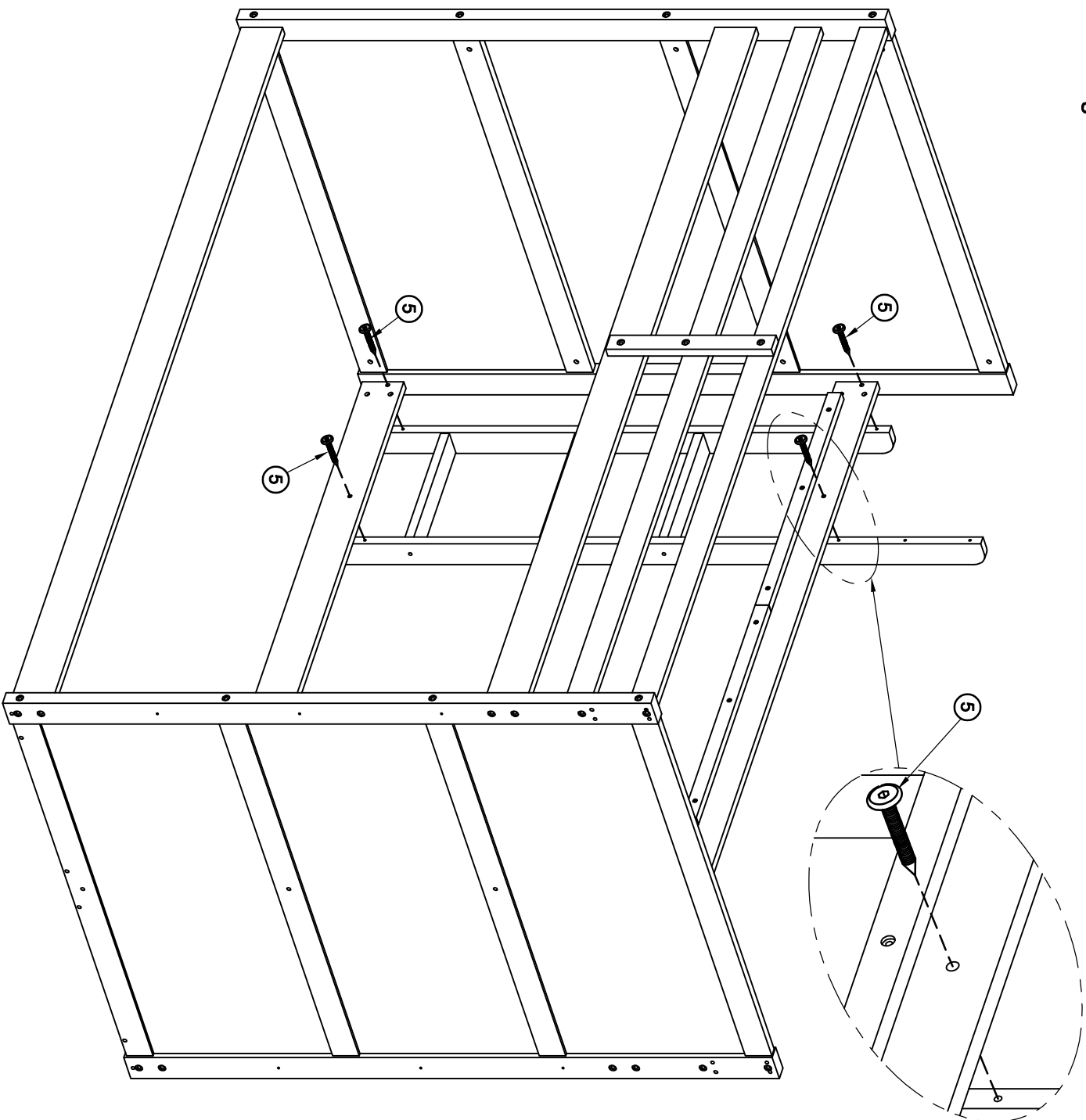

STEP 6: Following below illustration.

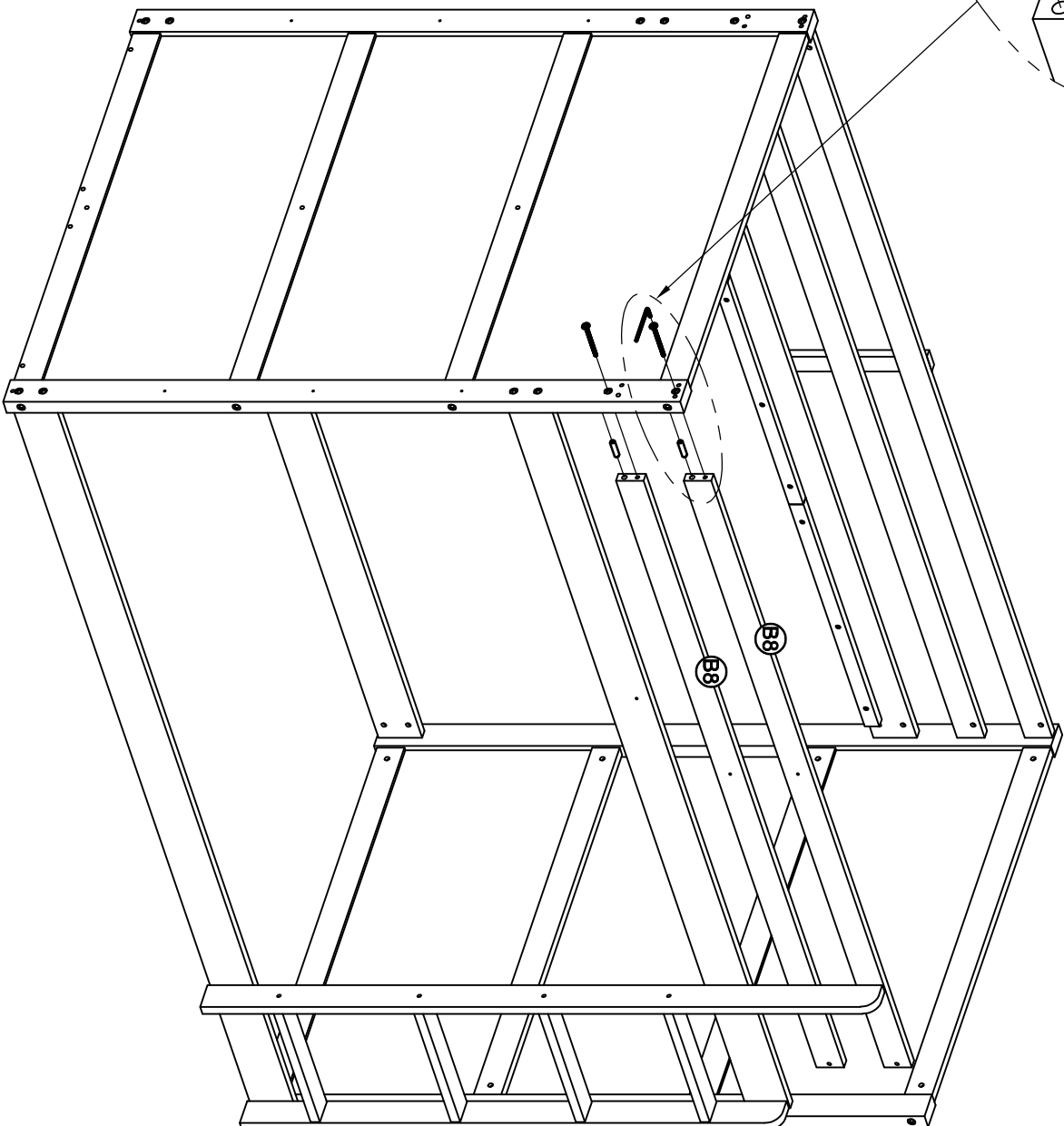
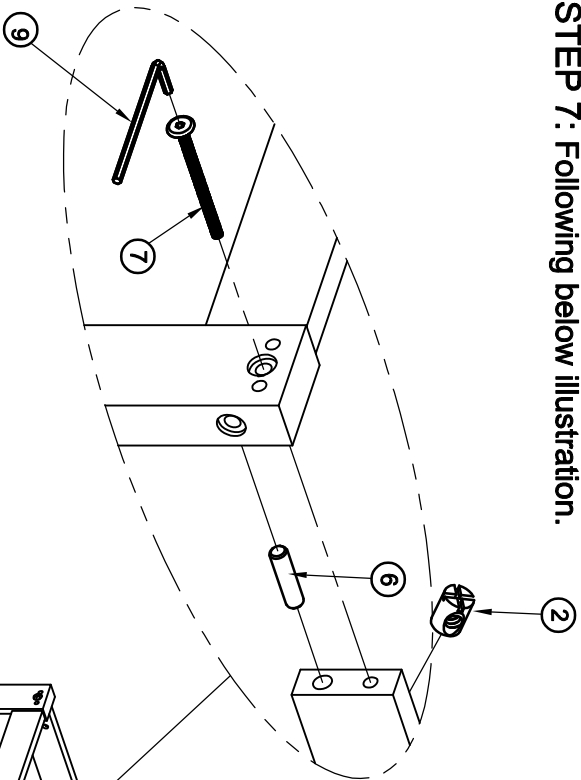

5	
4 (pcs)	

STEP 7: Following below illustration.



7		2 (pcs)
2		2 (pcs)
6		2 (pcs)

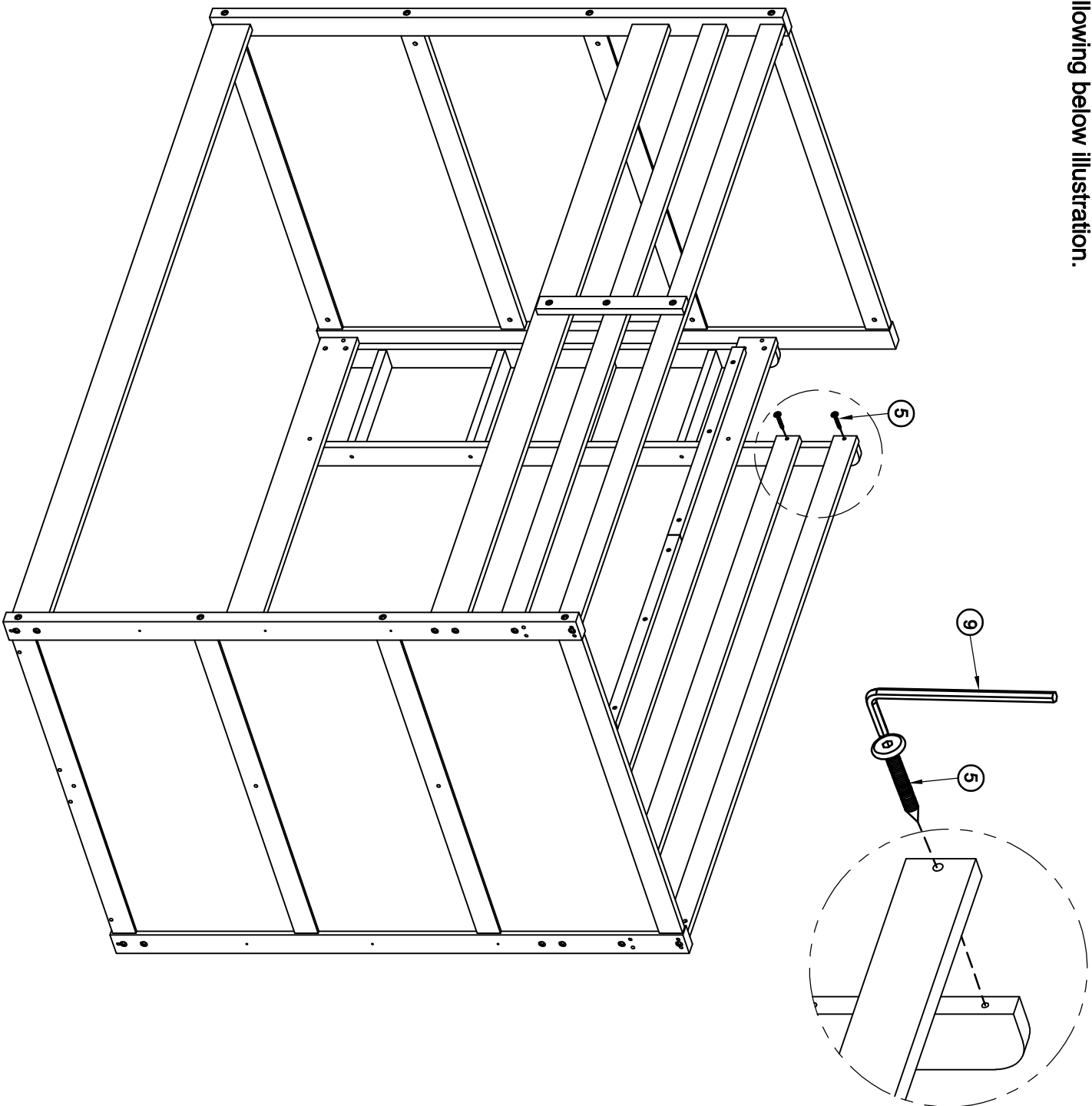

STEP 8: Following below illustration.

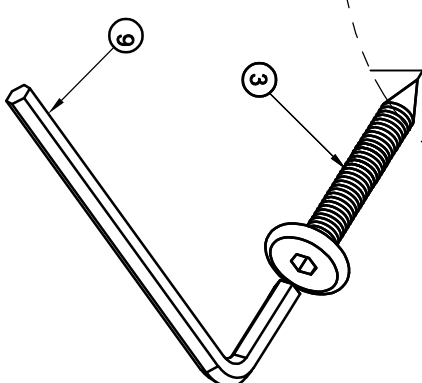
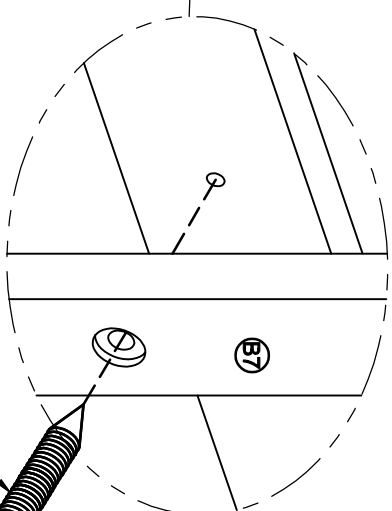
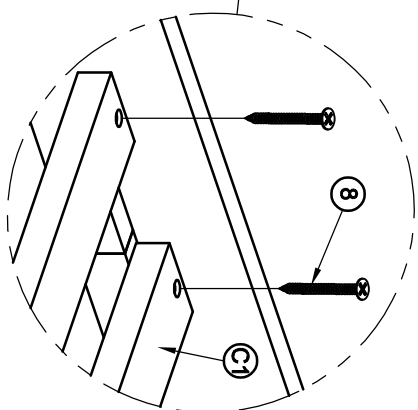
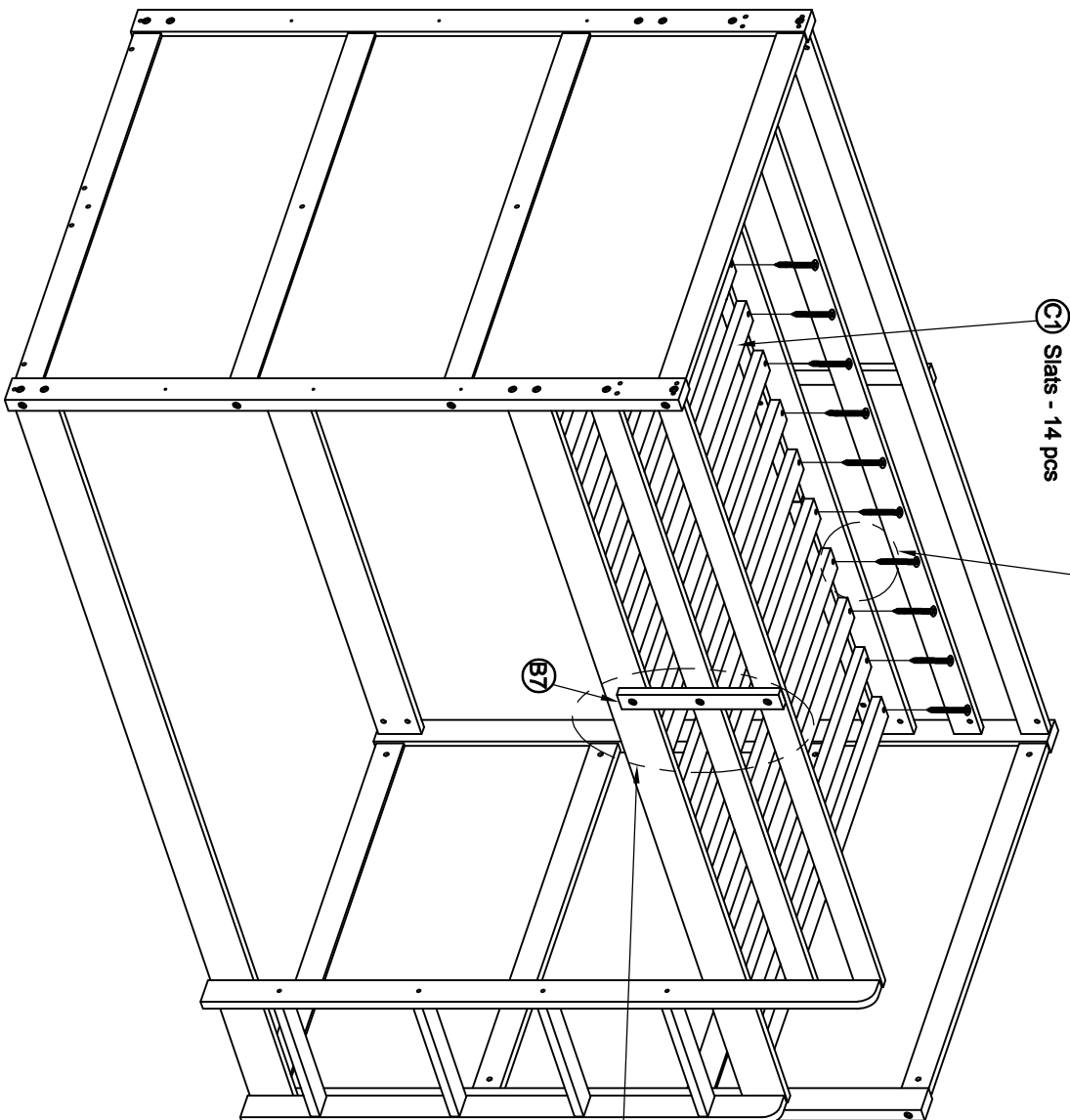

5	
2 (pcs)	

STEP 9: Following below illustration.



8		3	
14(pcs)		3(pcs)	

STEP 10: Following below illustration.

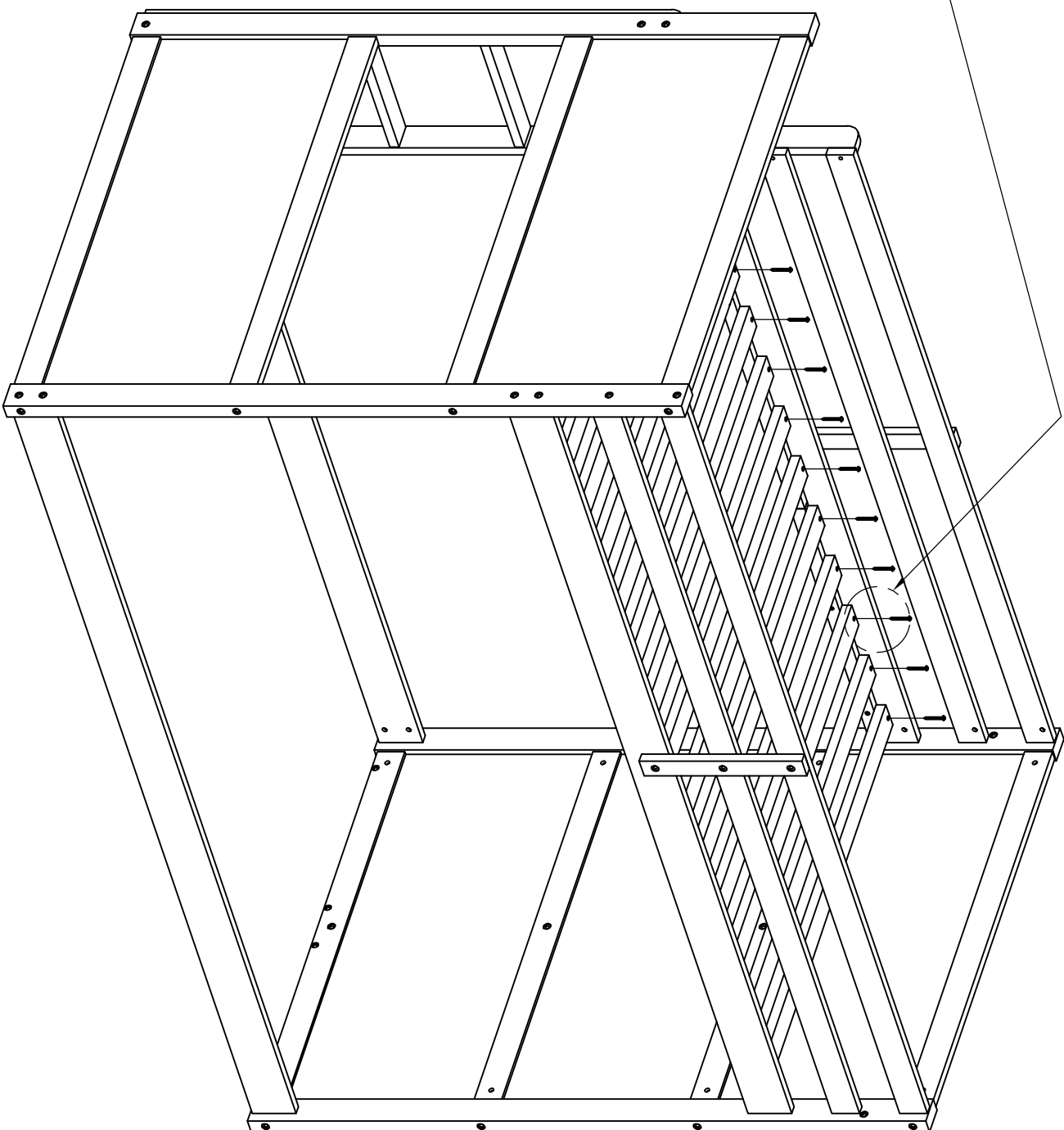
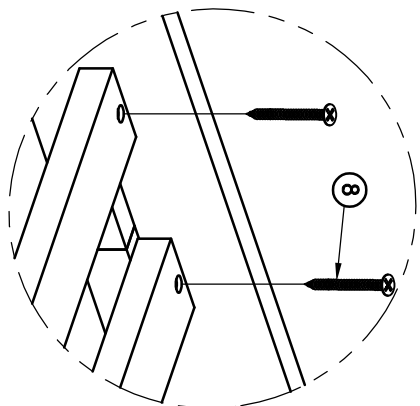

8

14(pcs)

STEP 11: Following below illustration.

X 2

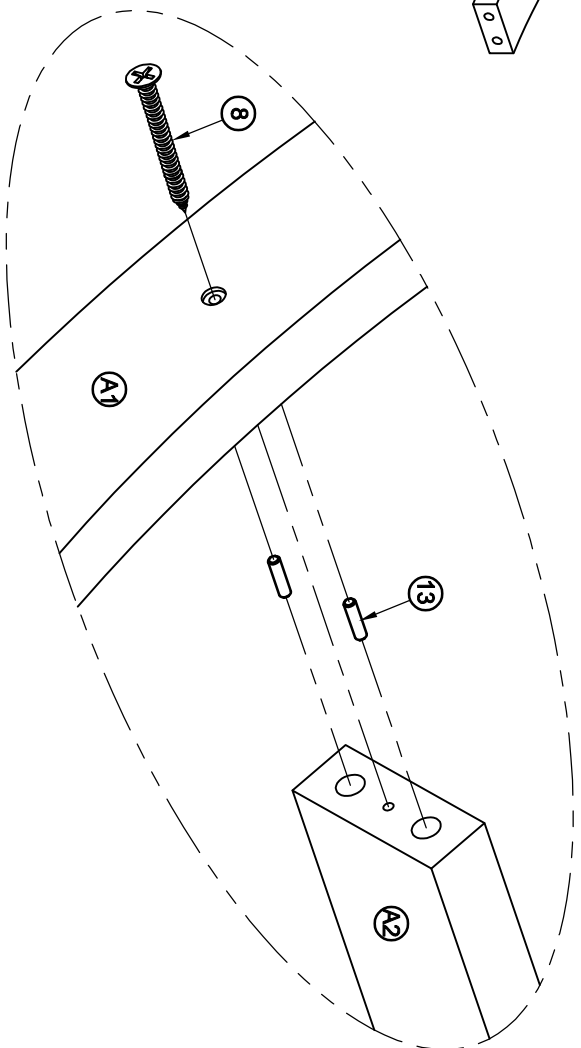
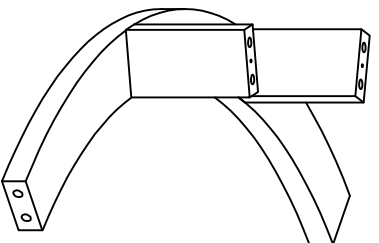
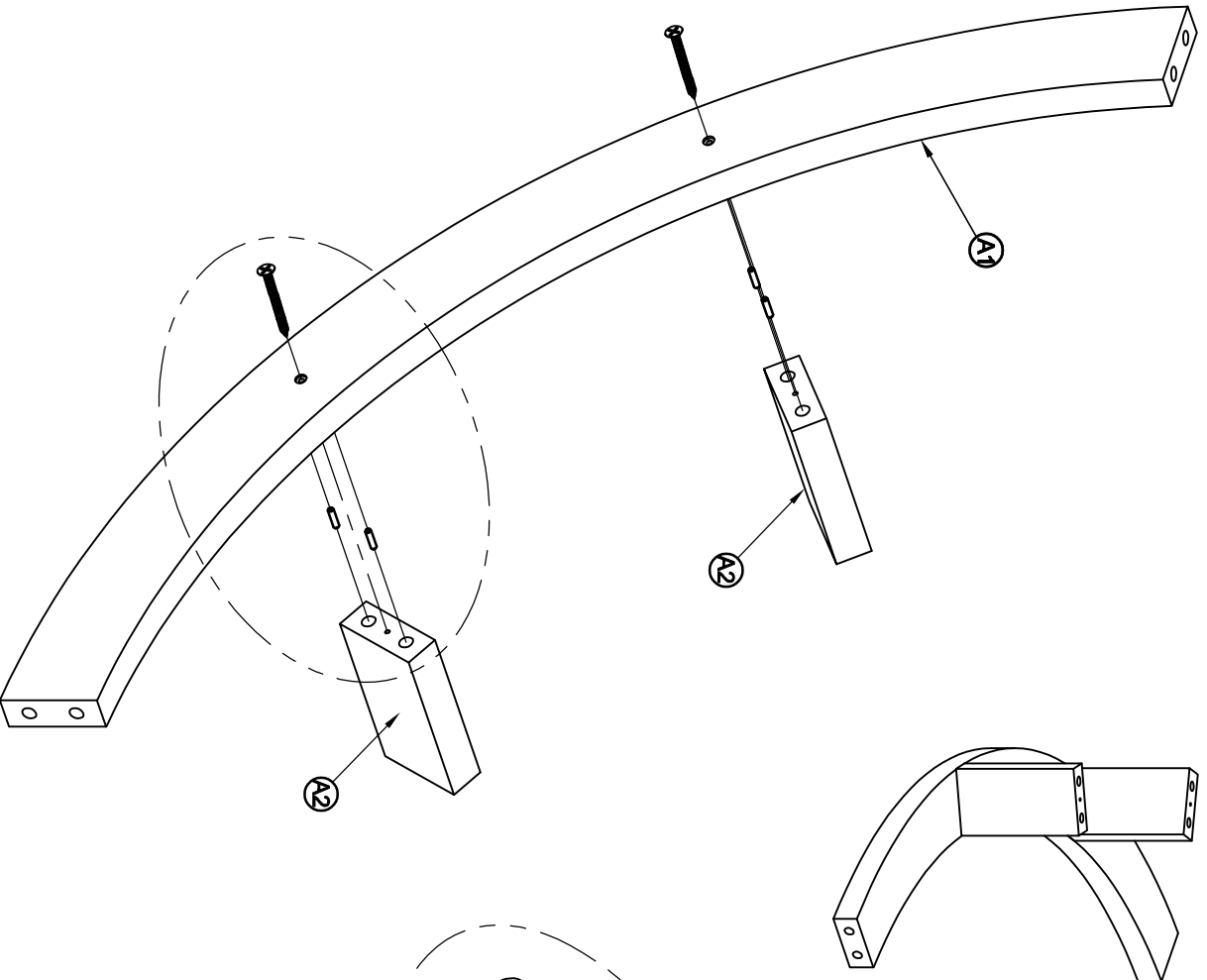

13		8	
8 (pcs)		4 (pcs)	

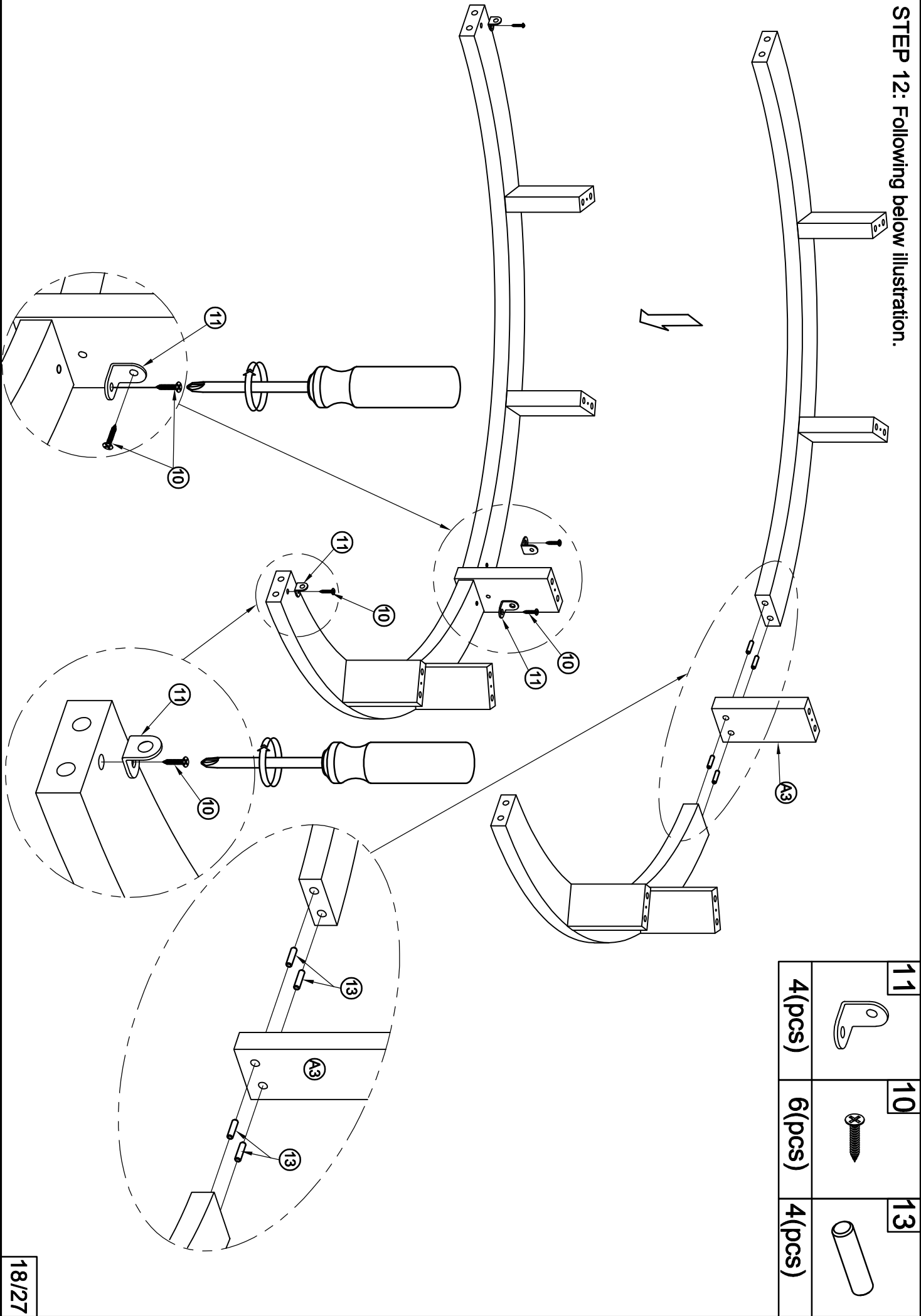

STEP 12: Following below illustration.



11		4(pcs)
10		6(pcs)
13		4(pcs)

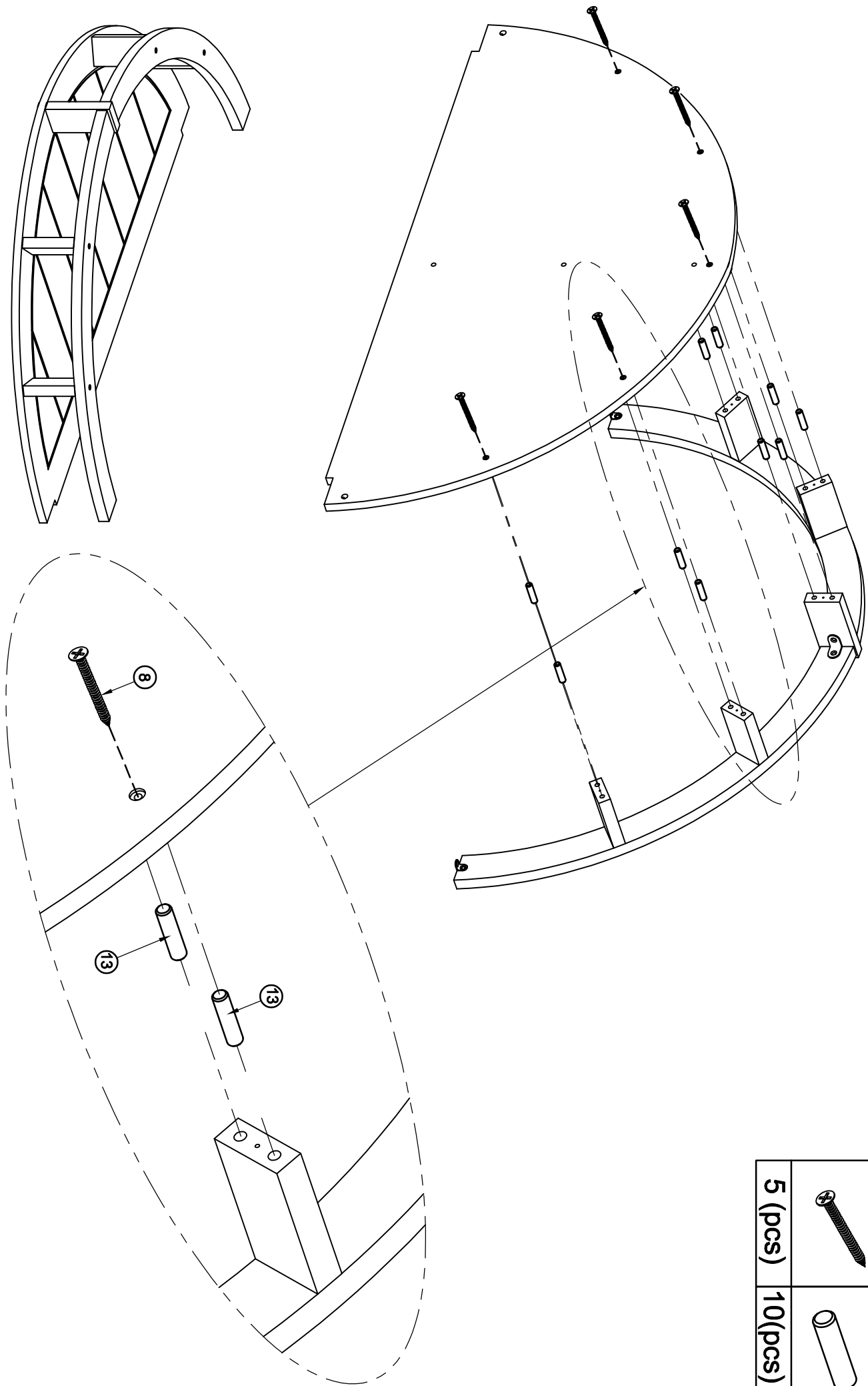

STEP 13: Following below illustration.

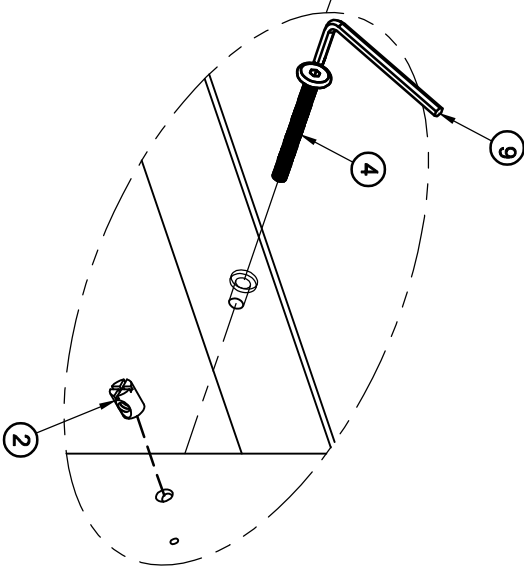
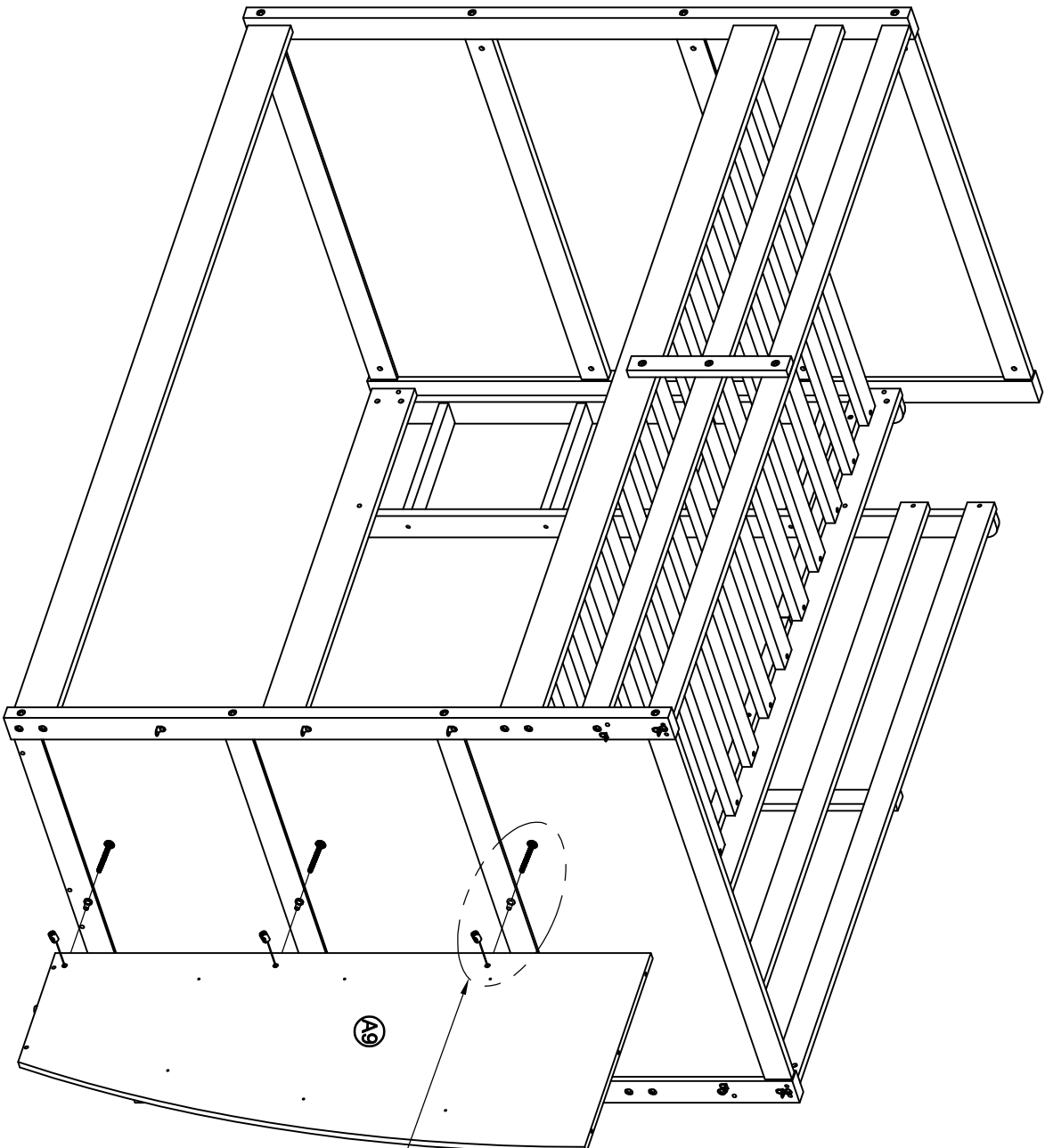

8		13
5 (pcs)		
10(pcs)		

STEP 14: Following below illustration.



4		2	
3 (pcs)		3 (pcs)	

STEP 15: Following below illustration.

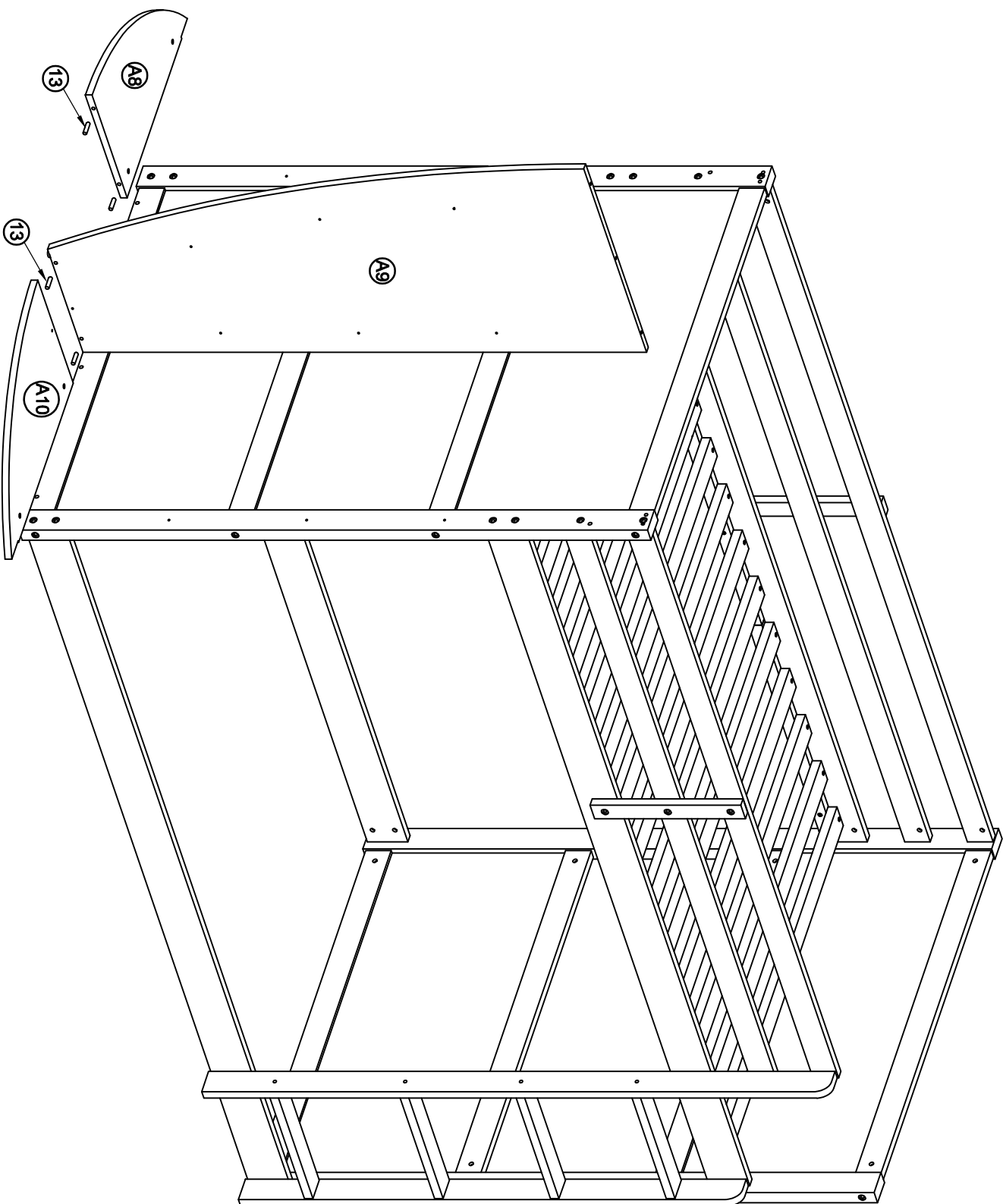



13



4(pcs)

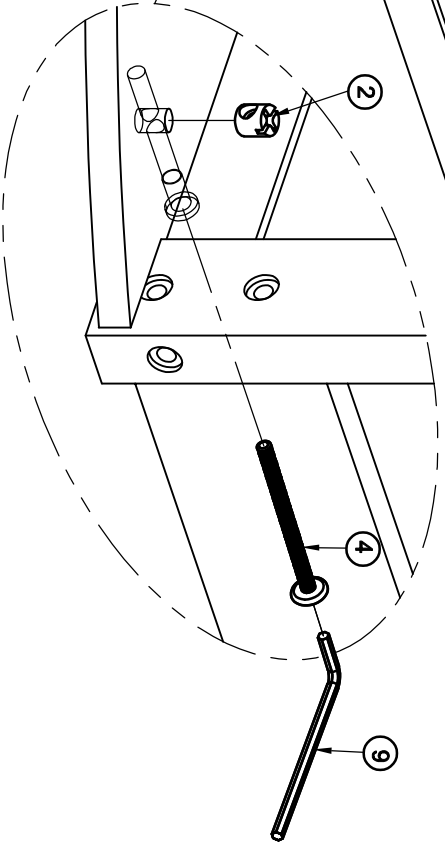
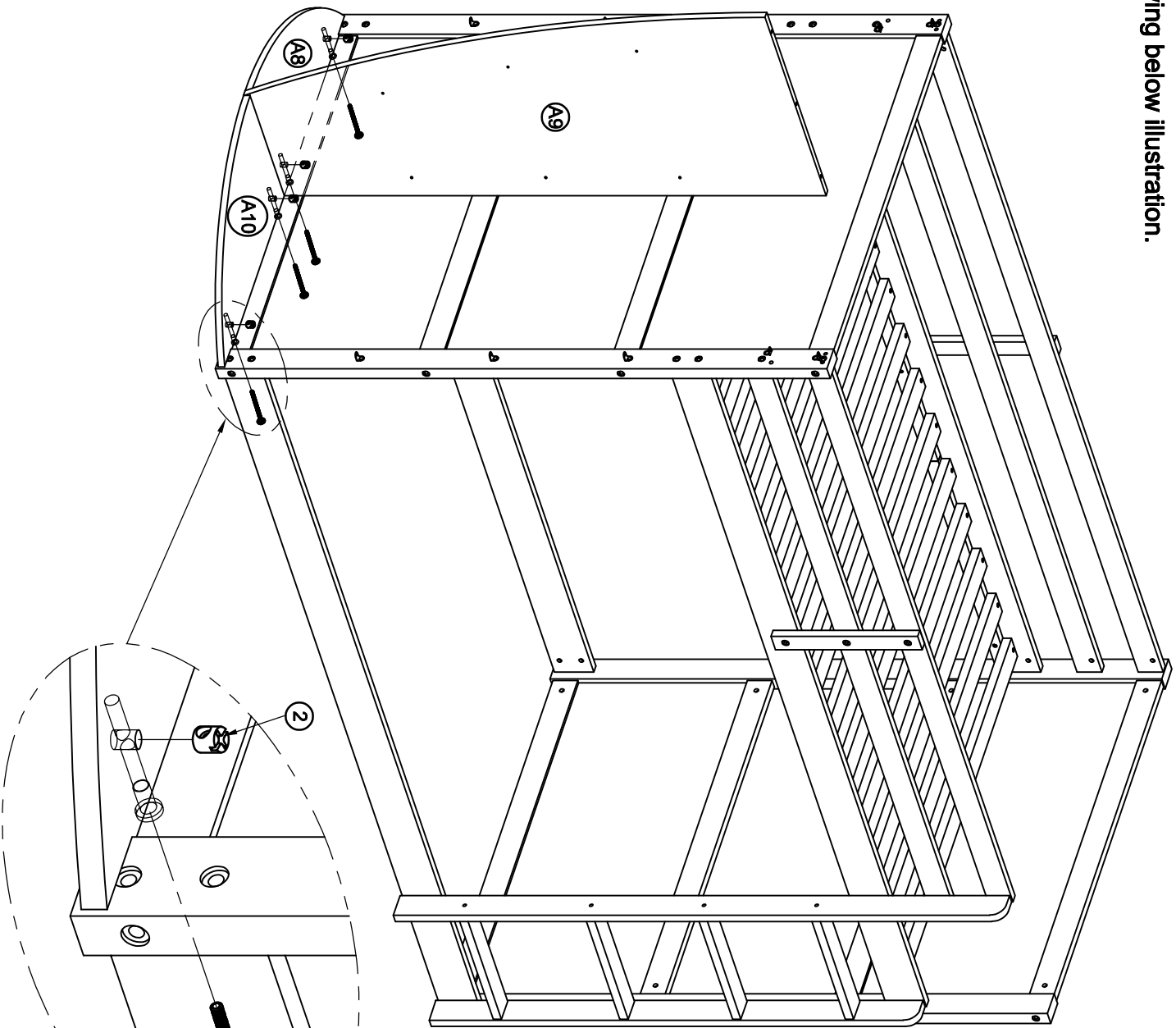





STEP 16: Following below illustration.

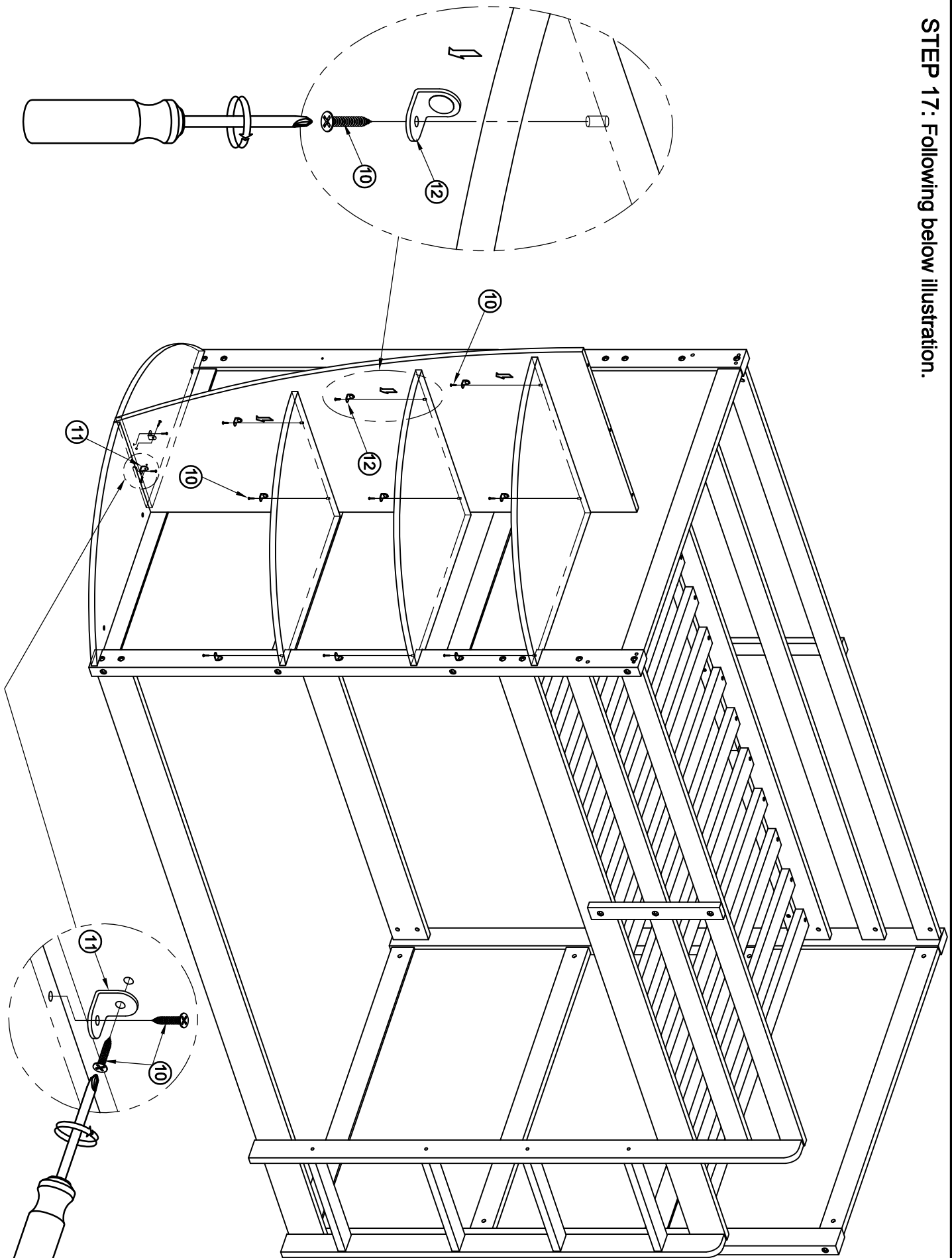

4		2	
4 (pcs)		4 (pcs)	



STEP 17: Following below illustration.



11	
2 (pcs)	
12	
9 (pcs)	
10	
13 (pcs)	

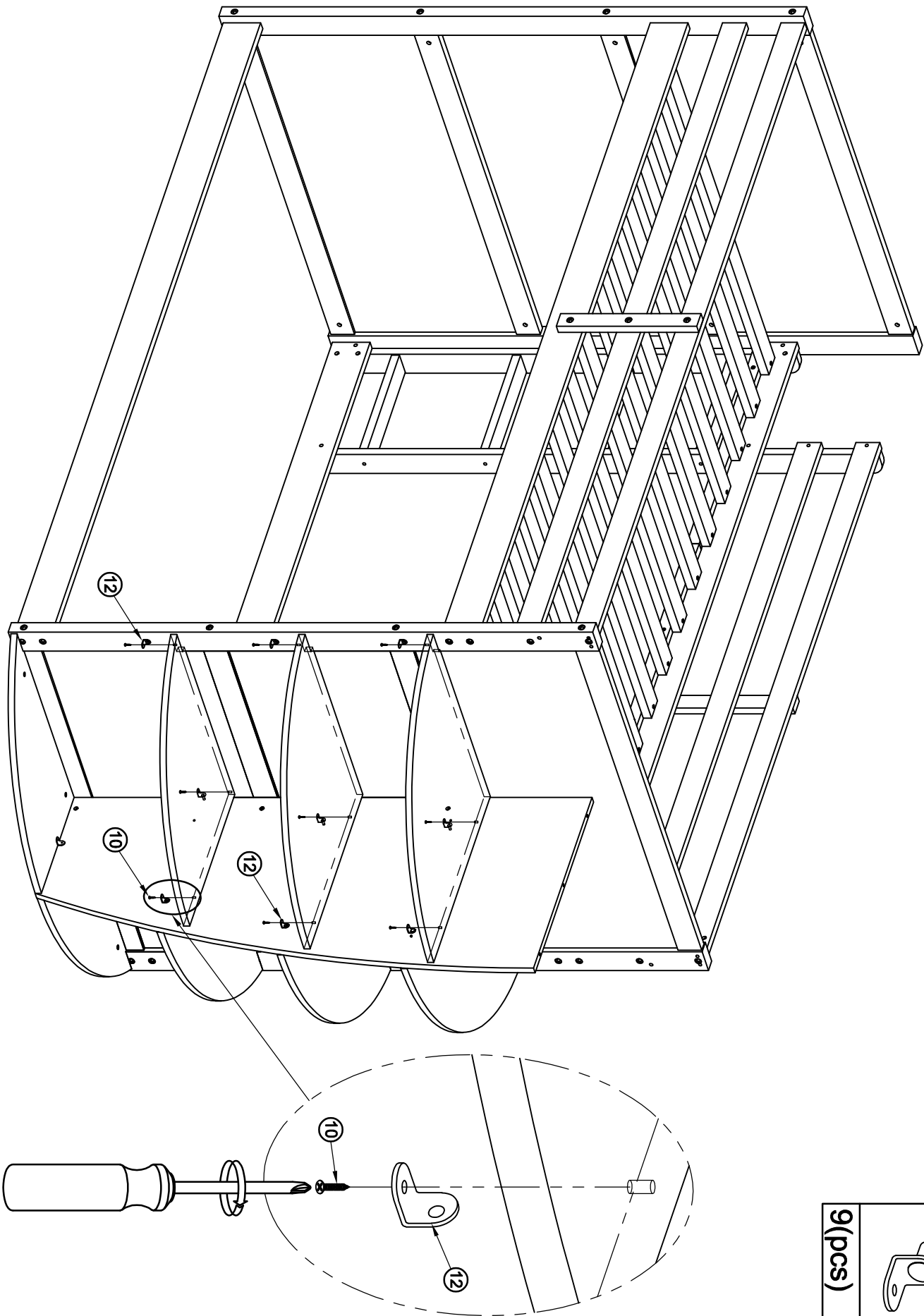

STEP 18: Following below illustration.



12		10	
9(pcs)		9(pcs)	

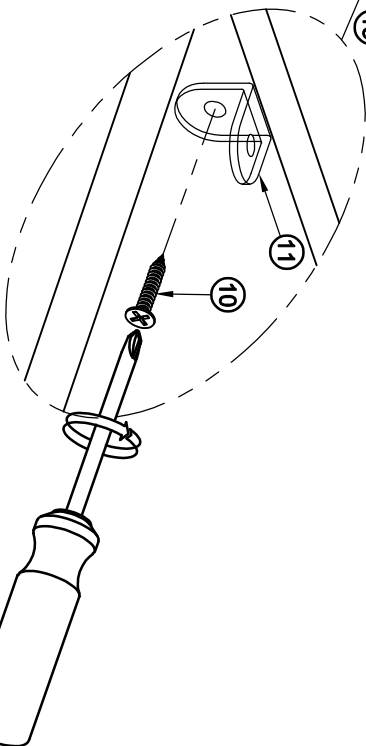
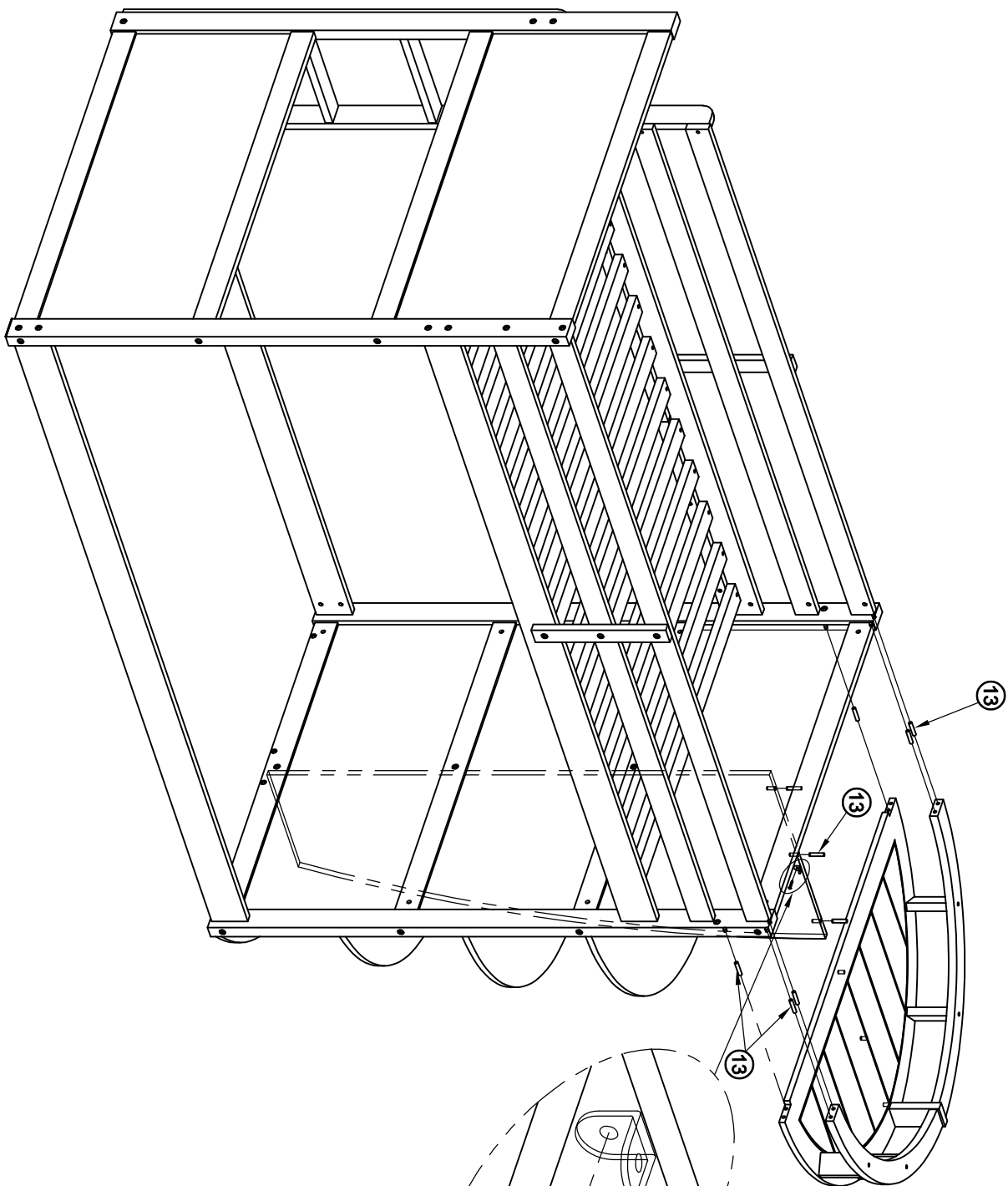

STEP 19: Following below illustration.

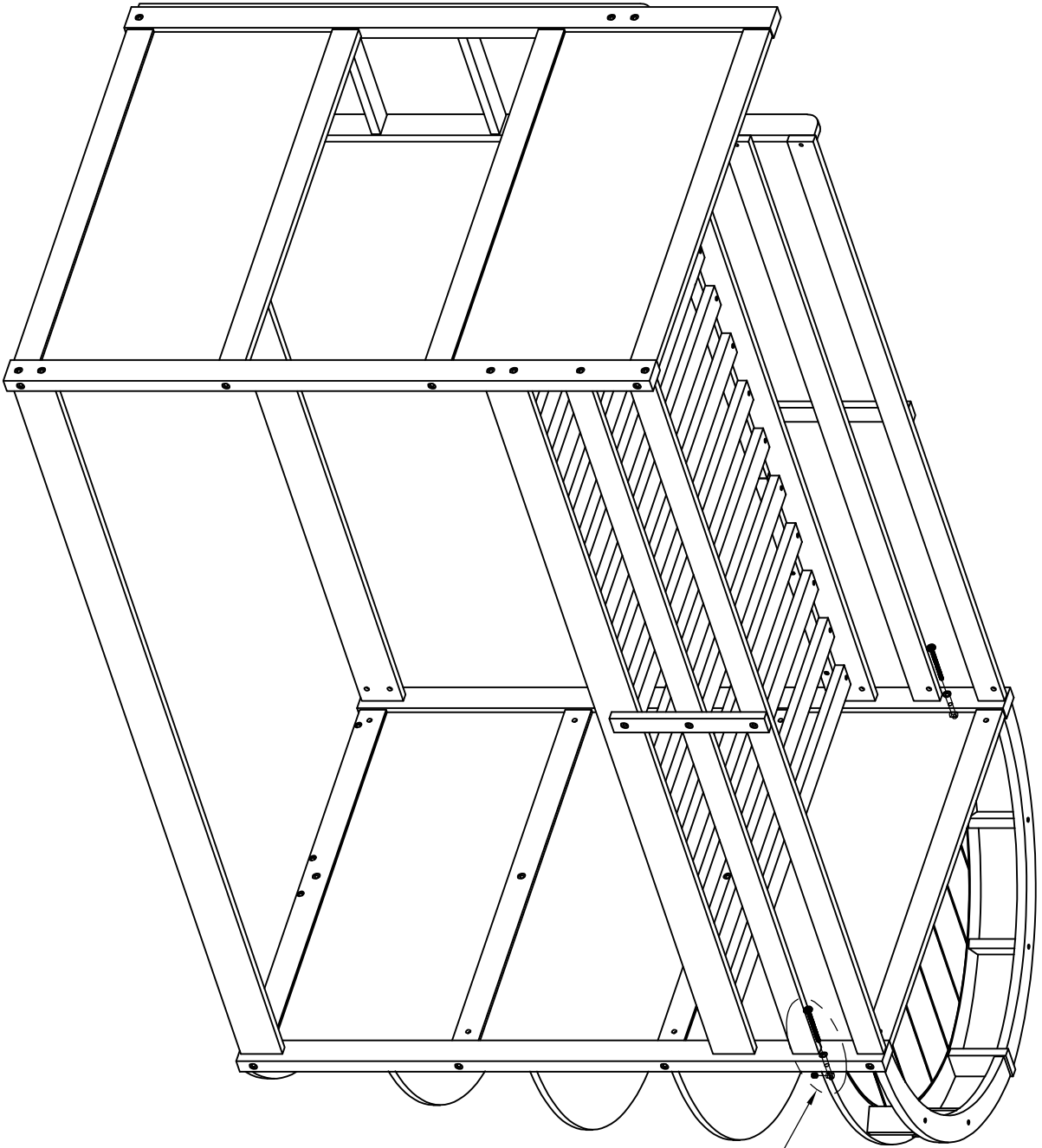

11		10		13	
1 (pc)		1 (pc)		9 (pcs)	

STEP 20: Following below illustration.



7		2	
2 (pcs)		2 (pcs)	

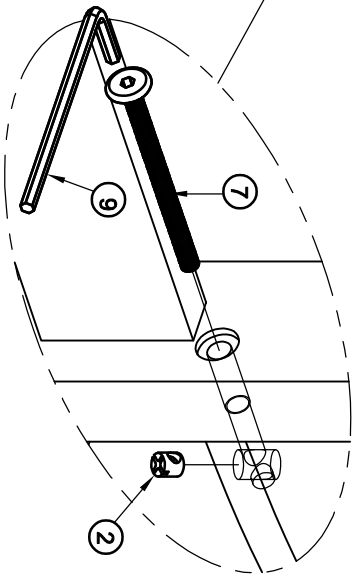

STEP 21: Following below illustration.

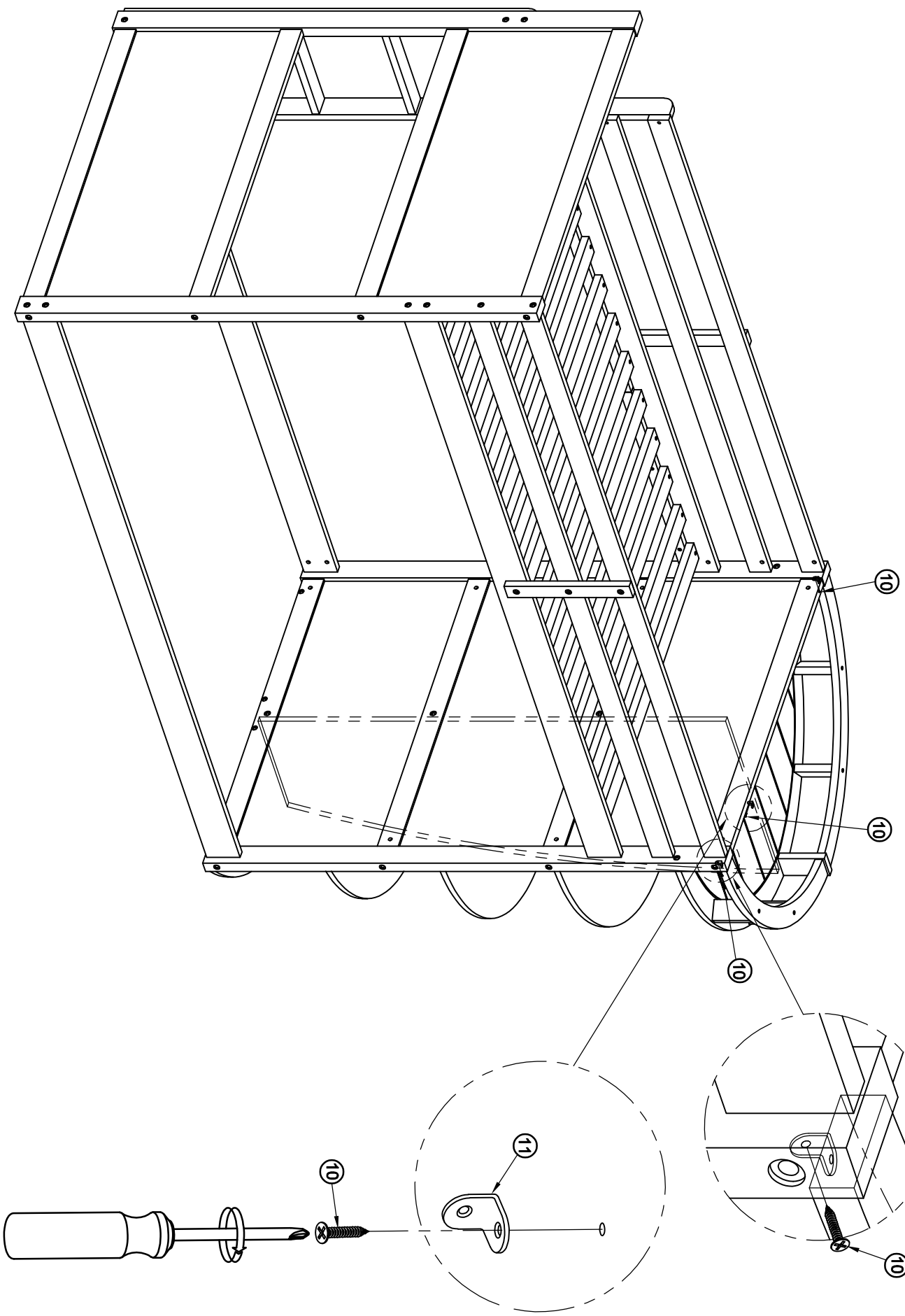

10

3(pcs)