

# ASSEMBLY INSTRUCTIONS

## WF307726/WF307727

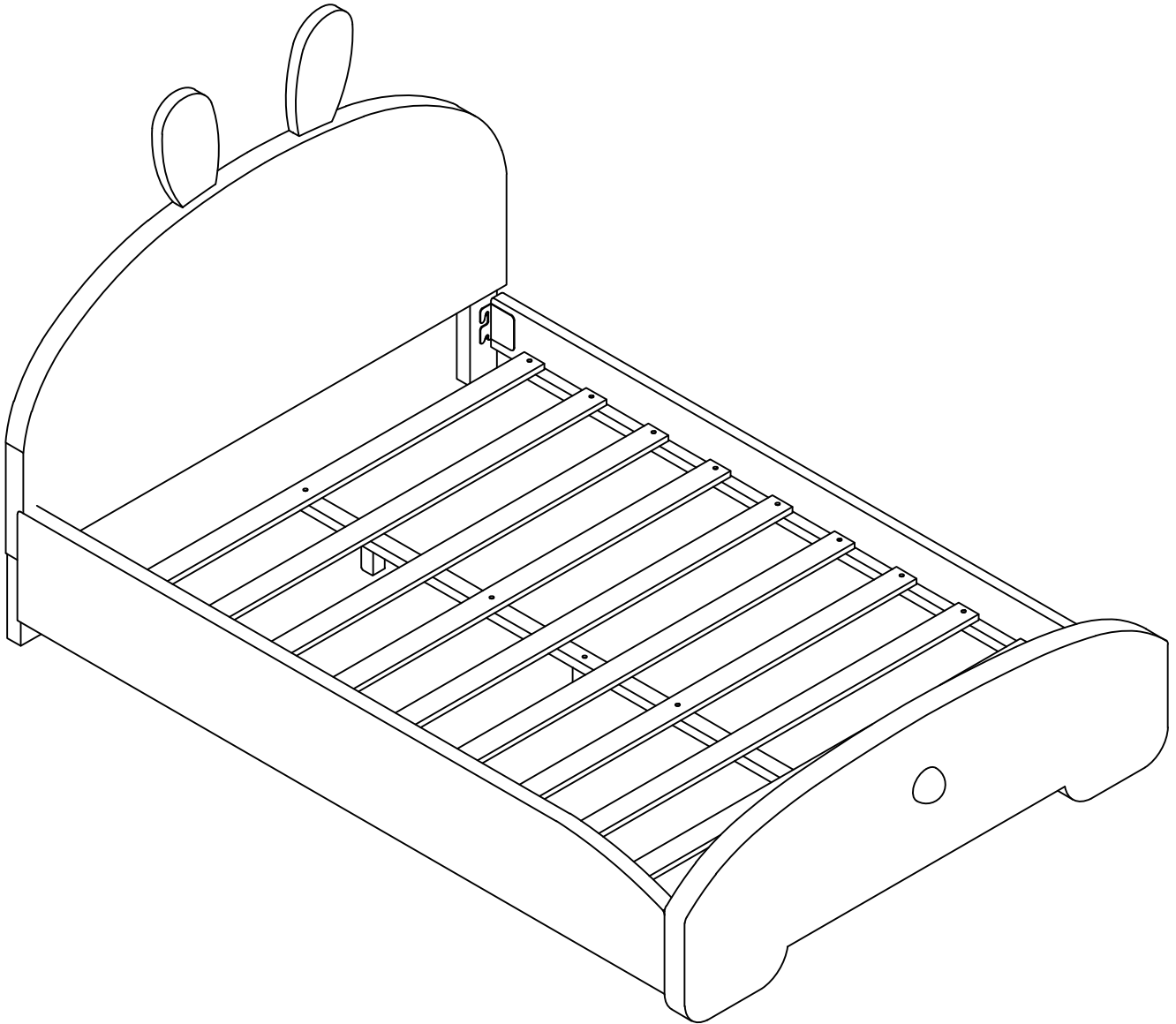

### IMPORTANT NOTE

**\*\*PLACE ALL PARTS ON A CLEAN AND SMOOTH SURFACE SUCH AS A RUG OR CARPET TO AVOID THE PARTS FROM BEING SCRATCHED**

**\*\* BEFORE YOU BEGIN , KINDY FOLLOW THE ASSEMBLY INSTRUCTIONS STEP BY STEP**

**\*\*DO NOT TIGHTEN ALL SCREWS AND BOLTS UNTIL THE BED IS FULLY SET-UP**

# ASSEMBLY INSTRUCTIONS

## WF307726/WF307727

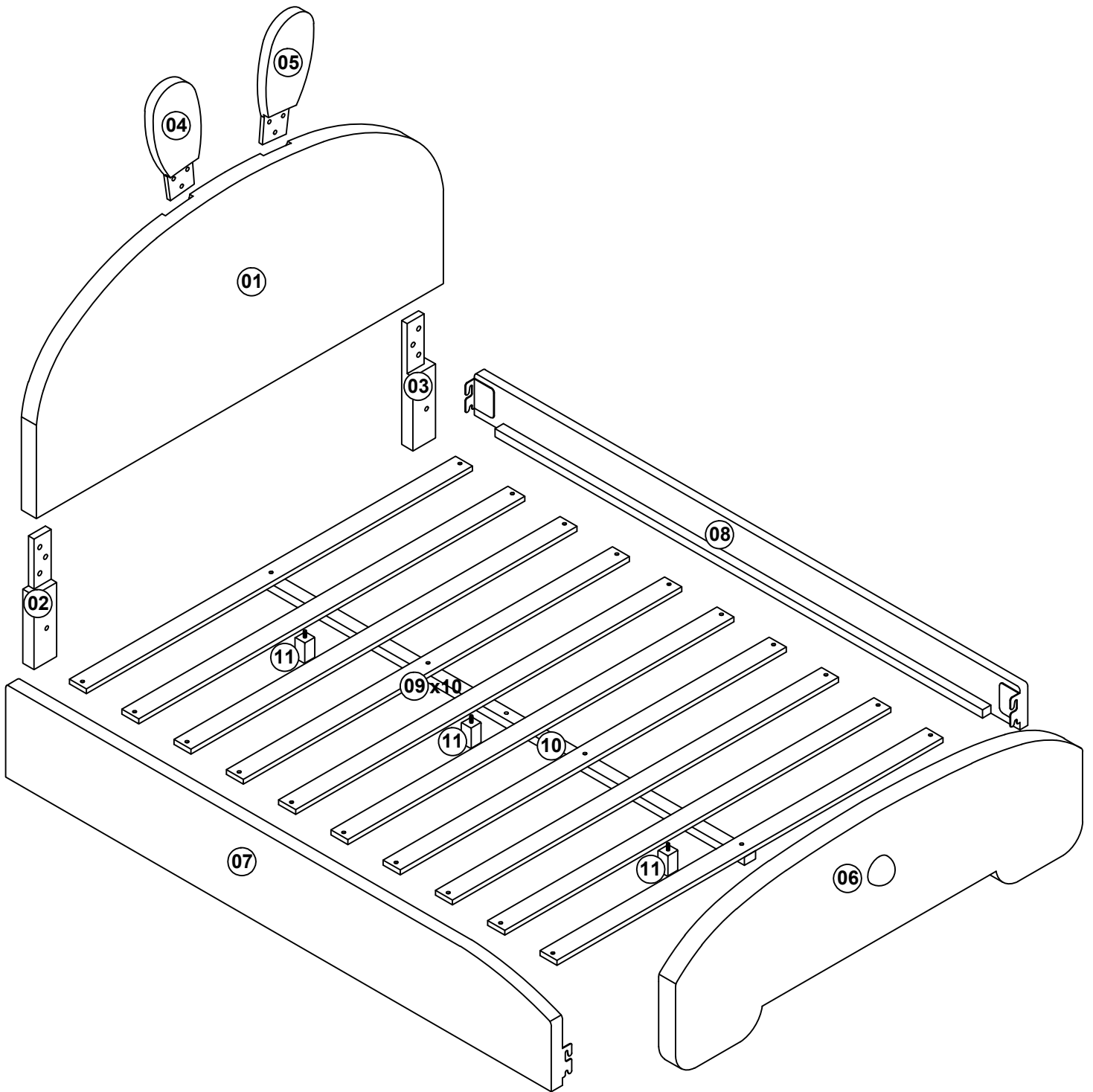

# ASSEMBLY INSTRUCTIONS

## WF307726/WF307727

### PART LIST BOX 1: WF307726

1

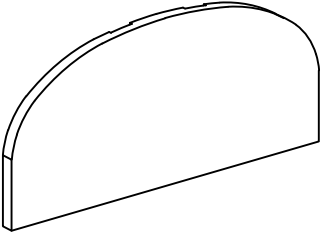

Headboard Panel (1 pc)

2



Left Headboard leg (1 pc)

3

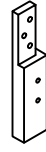

Right Headboard Leg (1 pc)

4

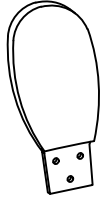

Left Headboard Ear (1 pc)

5



Right Headboard Ear (1 pc)

6

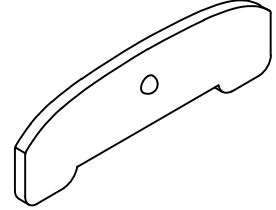

Footboard Panel (1 pc)

### PART LIST BOX 2: WF307727

7

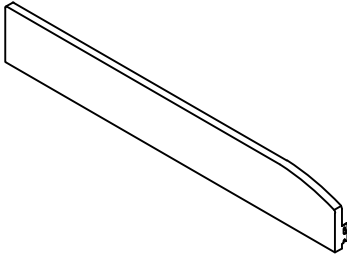

Left Side Rail (1 pc)

8

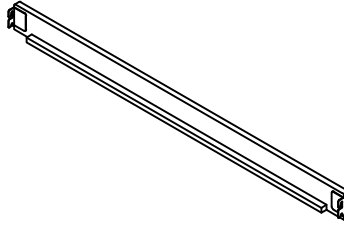

Right Side Rail (1 pc)

9

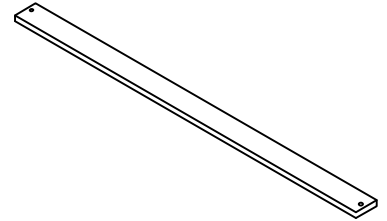

Slat Roll (10 pcs)

10

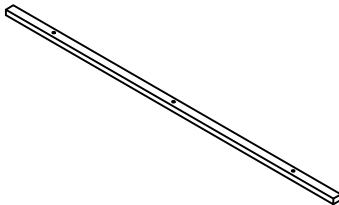

Center Rail (1 pc)

11

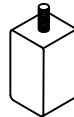

Support leg (3 pcs)

# ASSEMBLY INSTRUCTIONS

## WF307726/WF307727

### HARDWARE LIST IN: WF307726

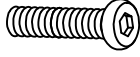
**A**

**Short Bolt (8pcs)**  
(Ø 5/16 "X25mm)

**B**

**Long Bolt (6 pcs)**  
(Ø 5/16 "X38mm)

**C**

**Long Bolt (6 pcs)**  
(Ø 5/16 "X32mm)

**D**

**Allen Wrench (1 pc)**  
(M4x75mm x32mm)

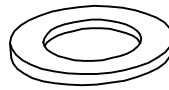
**E**

**Flat Washer (20 pcs)**  
(Ø 5/16 "-RBW)

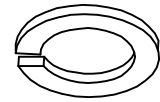
**F**

**Spring Washer (20 pcs)**  
(Ø 5/16 "-RBW)

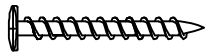



**G**

**Flat Head Screw (24 pcs)**  
(m4x30mm-RBW)

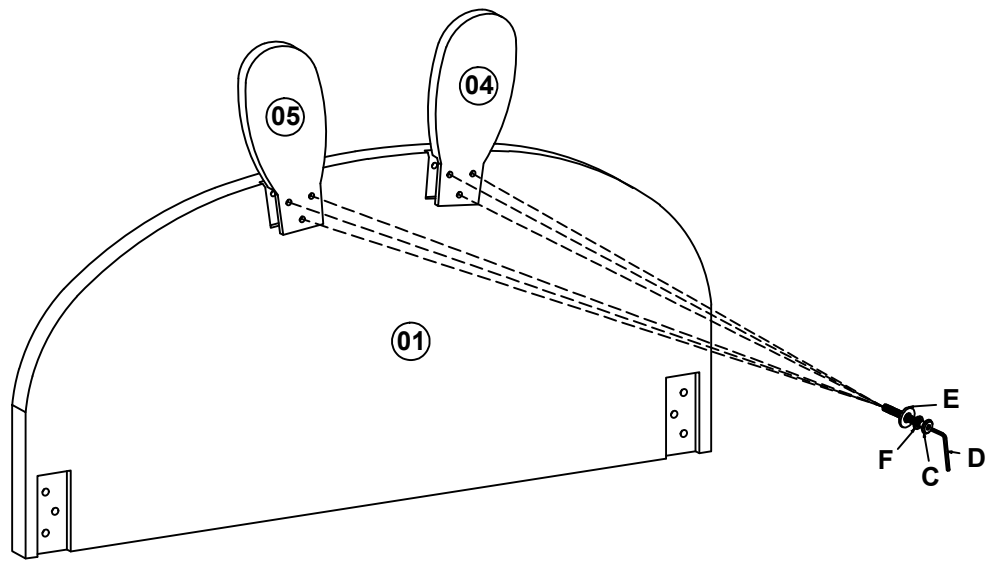
# ASSEMBLY INSTRUCTIONS





## STEP 1

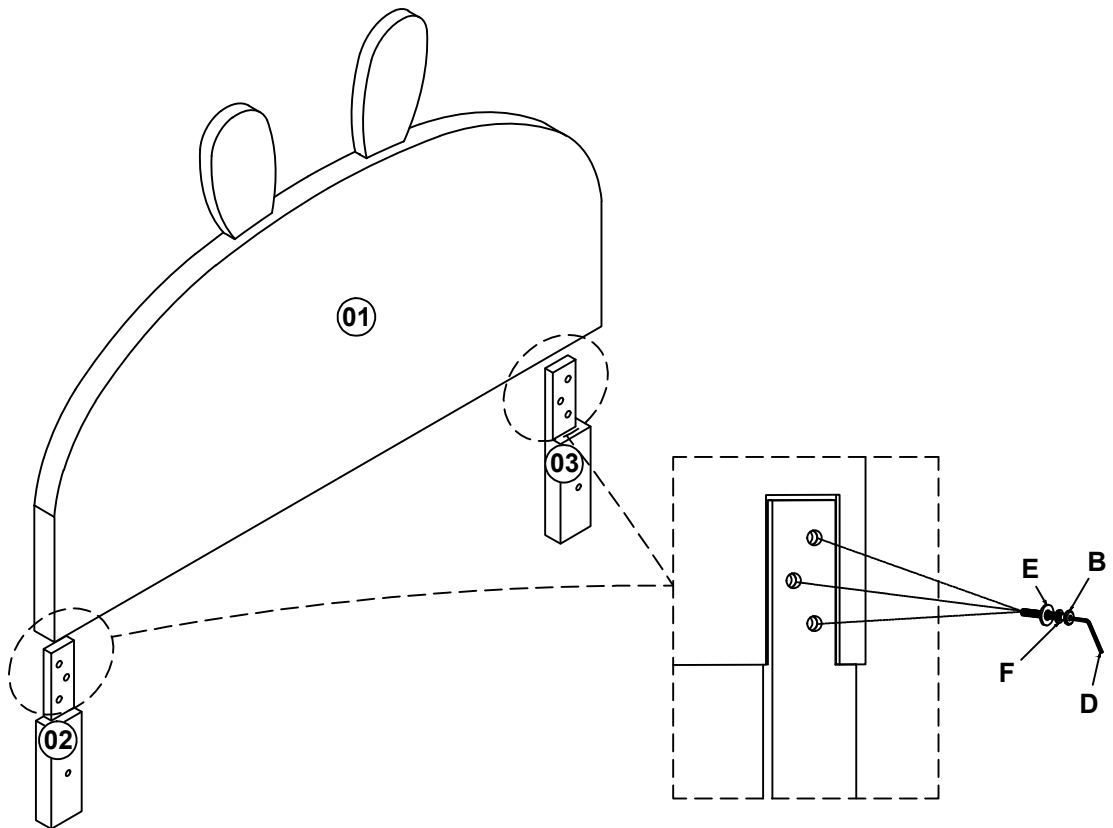

C	<b>Bolt</b> (Ø 5/16 "X32mm)		6pcs	E	<b>Flat Washer</b> (Ø 5/16 "-RBW)		6pcs
D	<b>Allen Wrench</b> (M4x75mm x32mm)		1pc	F	<b>Spring Washer</b> (Ø 5/16 "-RBW)		6pcs

## STEP 2





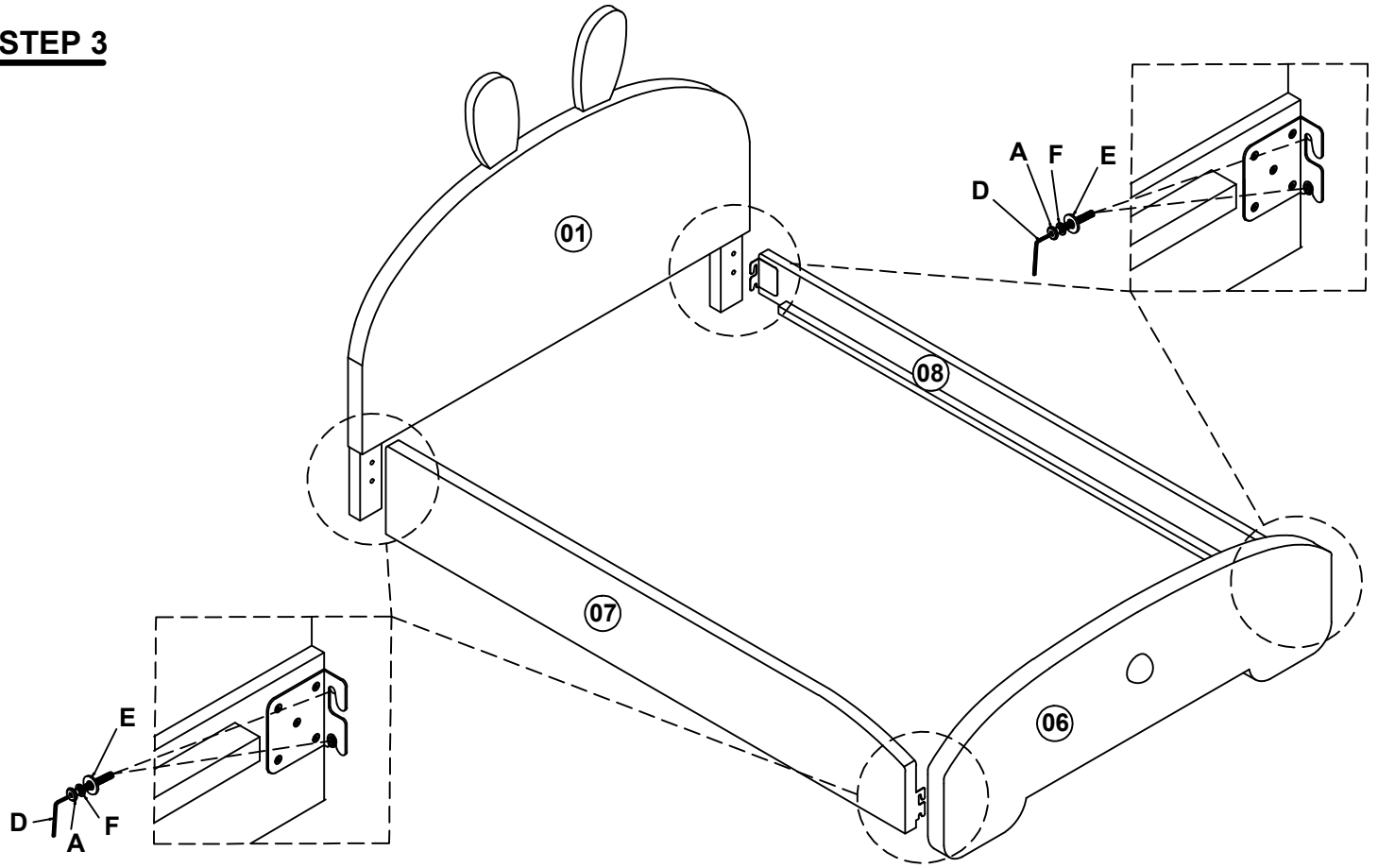

B		(Ø 5/16 "X38mm)	6pcs	E		(Ø 5/16 "-RBW)	6pcs
D		(M4x75mm x32mm)	1pc	F		(Ø 5/16 "-RBW)	6pcs

# ASSEMBLY INSTRUCTIONS

## STEP 3



A	<b>Bolt</b> (Ø 5/16 "X25mm)		8pcs	E	<b>Flat Washer</b> (Ø 5/16 "-RBW)		8pcs
D	<b>Allen Wrench</b> (M4x75mm x32mm)		1pc	F	<b>Spring Washer</b> (Ø 5/16 "-RBW)		8pcs

## STEP 4

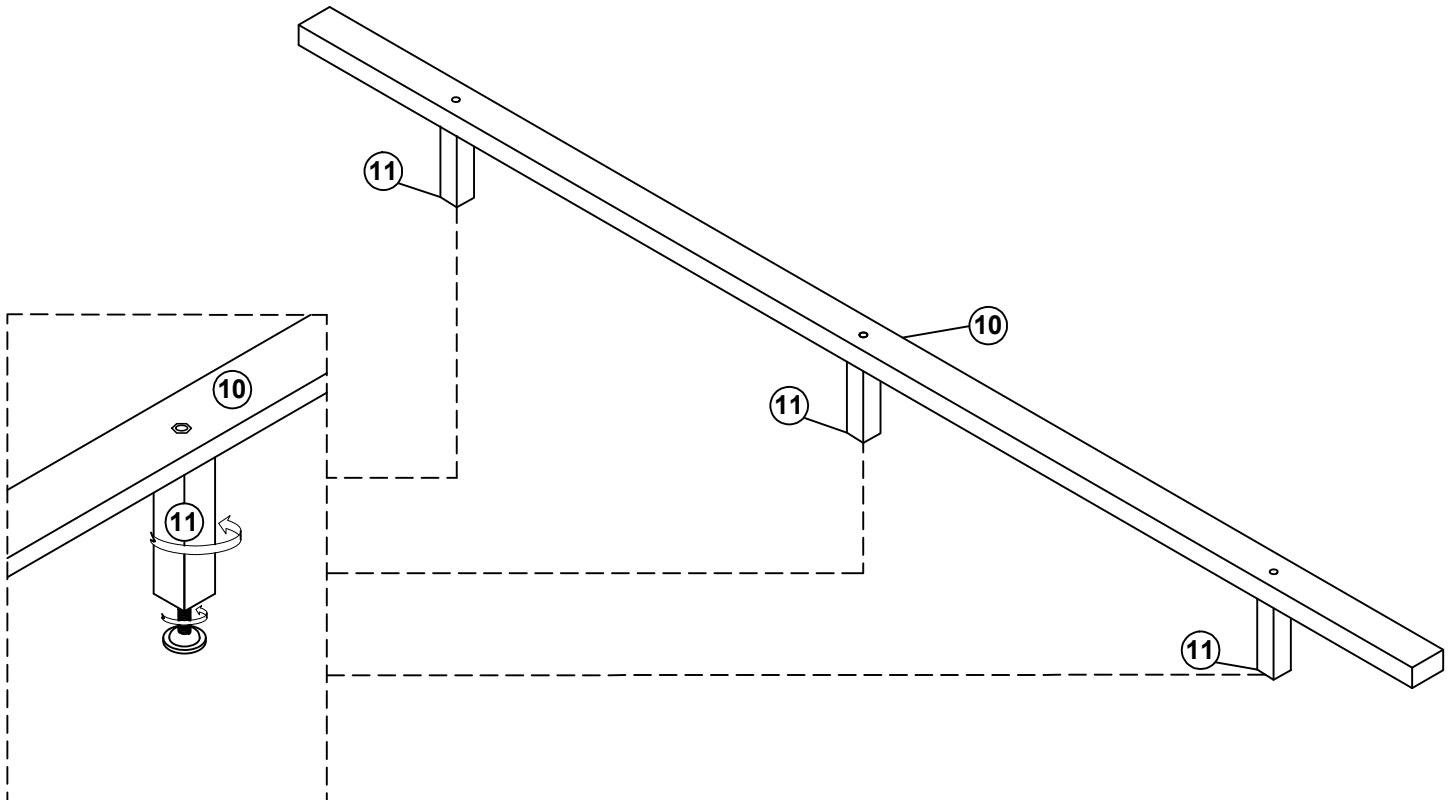

# ASSEMBLY INSTRUCTIONS

## STEP 5

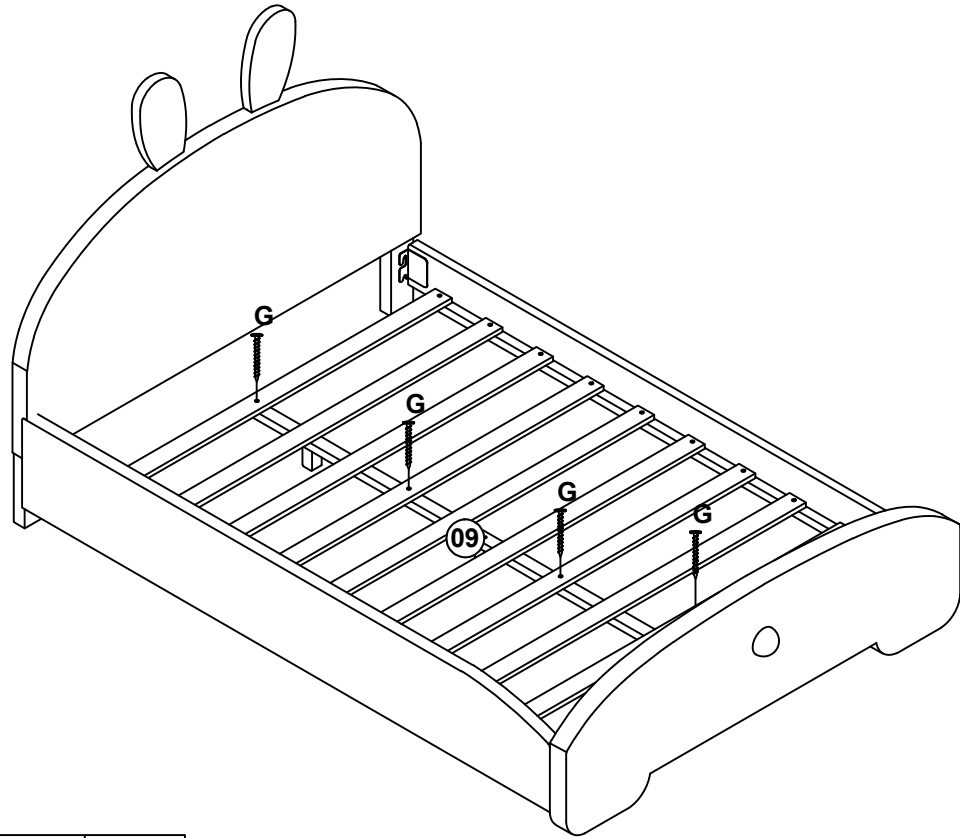

G		( m4x30mm-RBW)	4pcs
---	---	----------------	------

## STEP 6

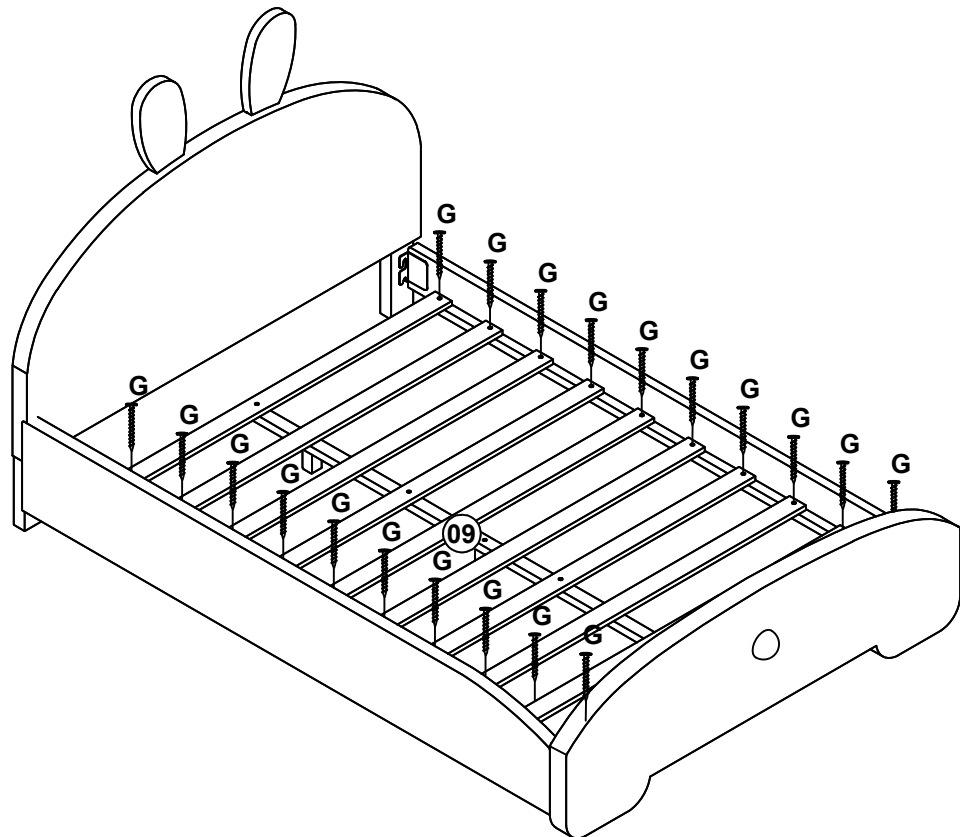

G		( m4x30mm-RBW)	20pcs
---	---	----------------	-------

# ASSEMBLY INSTRUCTIONS

## WF306677/WF306678

STEP 7  
COMPLETE

